



10341





LEGO.com/sustainable-packaging



FR
DONNEZ
OU
RECYCLEZ



ASSOCIATION

OU



MAGASIN

OU



DÉCHÈTERIE

Adresses sur quefairedemesdechets.fr



BUILDER



Apple and the Apple logo are trademarks of Apple Inc., registered in the U.S. and other countries and regions. App Store is a service mark of Apple Inc. Google Play and the Google Play logo are trademarks of Google LLC. Tencent and the Tencent logo are trademarks of Tencent Inc.

LEGO.com/devicecheck



LEGO® Builder



WIE FÜREINANDER GEMACHT

▼ Unsere wichtigste LEGO® Mission besteht darin, die Baumeisterinnen und Baumeister von morgen zu inspirieren. Alles ist möglich, es gibt keine Grenzen – und genau deshalb lockt uns der Weltraum! Seit mehr als 50 Jahren inspiriert die NASA immer wieder neue Generationen von kreativen, mutigen und bahnbrechenden Entdeckern. 2022 wurde die erste Artemis-Mission erfolgreich beendet, und in den nächsten Jahren werden weitere Missionen folgen. Die NASA kehrt auf den Mond zurück, um dort langfristig Menschen zu stationieren und in der Mondumlaufbahn und auf dem Mond selbst zu forschen. Als ersten Schritt auf dieser wissenschaftlichen Entdeckungsreise hat die NASA in Zusammenarbeit mit internationalen Raumfahrtbehörden und Raumfahrtexperten federführend das Space Launch System (SLS) und die Raumkapsel Orion entwickelt. Die Orion ist die bis dato leistungsstärkste Rakete und die vielseitigste Raumkapsel der NASA. Dieses Modell basiert auf der Artemis 1 der NASA (mit der Trägerrakete in der Konfiguration *Block 1*) mit der Raumkapsel Orion und bildet die Rakete detailgetreu nach, damit du so tun kannst, als würdest du das Raumfahrzeug immer wieder auf neue atemberaubende Weltraummissionen schicken. Freu dich auf ein Bauerlebnis, das dich zum Mond und weiter darüber hinaus reisen lässt.



WIR SCHREIBEN GESCHICHTE

Im Rahmen der Artemis-Missionen wird die NASA die erste Frau und die erste Person of Color auf den Mond bringen.

Mit einem Schub von 4 Millionen kg ist das SLS der NASA die bis dato leistungsstärkste Rakete.

Während der Artemis-I-Mission ist das Orion-Raumschiff bis 69.000 Kilometer hinter den Mond geflogen. Kein anderes auf den Transport von Menschen ausgelegtes Raumfahrzeug war jemals weiter von der Erde entfernt.

DIE REISE DER ARTEMIS I

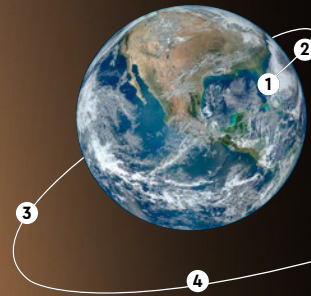

1 START

Das SLS der NASA hat einen Schub von fast 4 Millionen kg erzeugt, um die Erdanziehungskraft zu überwinden.

2 HAUPTSTUFE UND FESTSTOFFBOOSTER

Die Hauptstufe und die Feststoffbooster lösten sich, nachdem der Treibstoff verbraucht war.

3 ERDNAHE UMLAUFBAHN

Die Oberstufe der Rakete aus Interim Cryogenic Propulsion Stage (ICPS) und Orion beschleunigt auf mehr als 28.000 km/h und begibt sich in eine kreisförmige Erdumlaufbahn. Orion verlässt die erdnahe Umlaufbahn (Low-Earth Orbit, LEO) und umrundet die Erde!

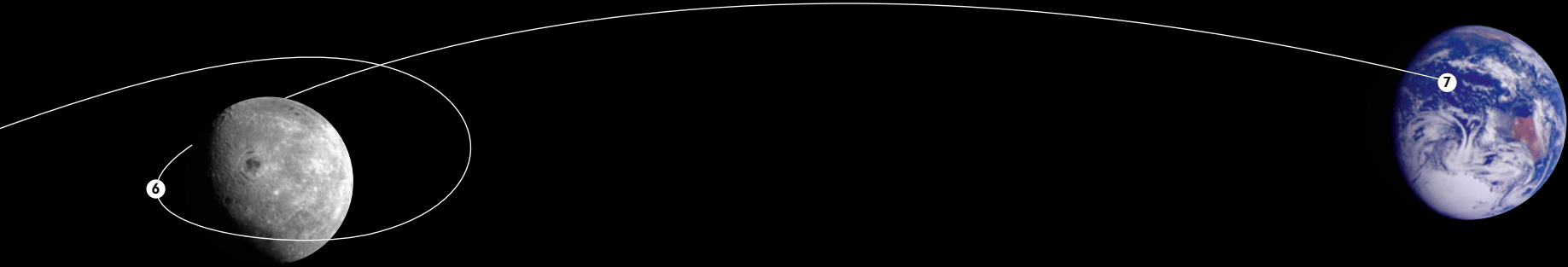

4 TRANS-LUNAR INJECTION (TLI)

Die ICPS hat das Raumschiff auf eine Geschwindigkeit beschleunigt, mit der Orion die Erdanziehungskraft überwindet und die erdnahe Umlaufbahn verlässt, um sie nah genug an den Mond zu bringen, damit sie von dessen Anziehungskraft erfasst wird.

5 AUF ZUM MOND

Die ICPS hat sich von Orion gelöst. Orion auf der dreiwöchigen Mission zum Mond, während die vom OSA/ICPS ausgesetzten CubeSats auf einer ähnlichen Flugbahn weiterflogen, um den Mond und die Tiefen des Alls zu erforschen.

6 ERPROBUNG DER SYSTEME IM ALL

Orion zündete die Navigationstriebwerke an seinem Servicemodul, um das Raumschiff auf die Rückseite des Mondes zu manövrieren. Die NASA erprobte die kritischen Systeme im All.

7 RÜCKKEHR ZUR ERDE

Beim Wiedereintritt in die Erdatmosphäre muss der Hitzeschild der Raumkapsel Temperaturen von bis zu 2.760 °C standhalten (an der Oberfläche der Sonne ist es ungefähr doppelt so heiß!). Dann wird Orion vor der Küste Kaliforniens aus dem Pazifik geborgen.

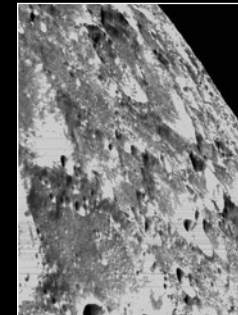
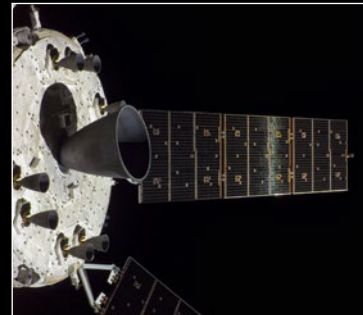
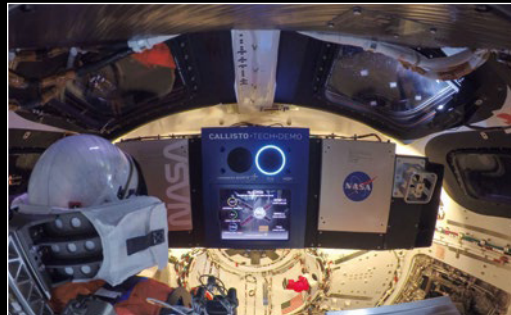



ARTEMIS I-V

▼ Zu Ehren der Apollo-Missionen (1961-1972) bediente sich die NASA bei der Namensgebung für ihre aktuellen Mondmissionen ebenfalls in der griechischen Mythologie. Treffenderweise war Artemis nicht nur Apollos Zwillingsschwester, sondern auch die Göttin des Mondes. Nach erfolgreichen ersten Erprobungsflügen wurden vier zusätzliche Artemis-Missionen in den kommenden Jahren bestätigt. Jede dieser Missionen verfolgt das Ziel, das SLS und Orion in puncto Performance, Wiedereintrittsgeschwindigkeit, Einsatzfähigkeit im All und Beförderung von Nutzlasten zu optimieren. Letztendlich werden bemannte Missionen zum Mars – und noch tiefer ins All – angestrebt.

I

ERSTE MISSION
(UNBEMANNTE
FLUGERPROBUNG)

II

ERSTE BEMANNTE
FLUGERPROBUNG

III

BEMANNTE
MONDLANDUNG UND
MONDEXPEDITION

IV

ERSTE MISSION ZUM AUFBAU
EINER MONDSTATION

V

BEMANNTE MOBILE
MONDEXPEDITION
UND AUSBAU ZUM
LUNAR GATEWAY

ANMERKUNGEN DES LEGO® DESIGNERS



„Jedes auf echten Vorbildern basierende LEGO® Set hat eine Geschichte. Beim SLS der NASA können wir uns kaum ausmalen, welche Rolle es bei der Erforschung des Weltraums künftig noch spielen wird! Beim Design dieses Modells war einiges an LEGO Raketenwissenschaft erforderlich, denn wir wollten die verschiedenen Raketenstufen mit ihren Funktionen nachbilden. Für den Startturm war eine bestimmte Bautechnik erforderlich. Mit Stäben und LEGO Technic Verbindungselementen werden die Gittersegmente angefertigt und gestapelt. Genau wie beim Original verbindet ein Fahrzeugsicherungssystem die Rakete mit dem Startturm. Man muss nur ein kleines Rad drehen, um die einziehbaren Versorgungsleitungen vor dem Start zu lösen. Details wie Treppen und Türen veranschaulichen den Maßstab des Modells. Die Rakete selbst lässt sich von der Startrampe nehmen. Man kann beide Feststoffbooster trennen. Wenn man dann noch eine Verkleidung entfernt, wird die obere Raketenstufe entriegelt. Nach dem Öffnen kommt das Orion-Raumschiff zum Vorschein, das mit ausfaltbaren Solarmodulen ausgestattet ist. Genau wie die echte Trägerrakete lässt sich auch das Modell in kleinere Segmente zerlegen. Und das Orion-Raumschiff kann auch neben der Trägerrakete ausgestellt werden.

- Hans Burkhard Schlömer, LEGO® Modelldesigner

JEDES GRÖßERE ELEMENT DES SLS DER NASA ERFÜLLT EINEN BESTIMMTEN ZWECK

ORION-RAUMSCHIFF

Das Orion-Raumerschiff besteht aus drei Hauptelementen, dem Startabbruchsystem („Rettungsrakete“), dem Crewmodul und dem Servicemodul.

HAUPTSTUFE

Die Hauptstufe des SLS ist die größte Raketstufe, die von der NASA bis dato gebaut wurde. Sie ist 64,6 Meter lang und hat einen Durchmesser von 8,4 Metern. Voll betankt wiegt die Rakete ohne Triebwerke 1.088 Tonnen!

TRIEBWERKSSEGMENT

Das Triebwerkssegment beherbergt die vier Haupttriebwerke vom Typ RS-25, die Schubkonstruktion, die Treibstoffleitungen, die Bordelektronik und die Schubvektorsteuerungssysteme.

DÜSE

In die Heckschürze ist das Schubvektorsteuerungssystem integriert. Die Boosterabgasdüse wird von der Bordelektronik gesteuert.

LAUNCH ABORT SYSTEM (LAS)

Bei einem Notfall während des Starts bringen die drei Feststoffraketenmotoren dieses Startabbruchsystems („Rettungsrakete“) die Orion-Raumkapsel und ihre Crew von der Rakete weg und lassen sie sicher im Ozean wassern.

CREWMODUL

Das Crewmodul der Orion dient der Crew während des Flugs zum Mond als Aufenthaltsbereich, in dem Astronauten mit Nahrung, Wasser und Sauerstoff versorgt und gleichzeitig vor Gefahren wie der Weltraumstrahlung geschützt werden.

SERVICEMODUL

Das Servicemodul ist das Maschinenhaus, das Orion antreibt und mit Strom und Wärme sowie mit Luft und Wasser für die Astronauten versorgt.

FESTSTOFFBOOSTER

Die Feststoffbooster des SLS werden als Erstes an der mobilen Startplattform installiert. Voll mit Treibstoff befüllt wiegt jeder Booster 726 Tonnen!

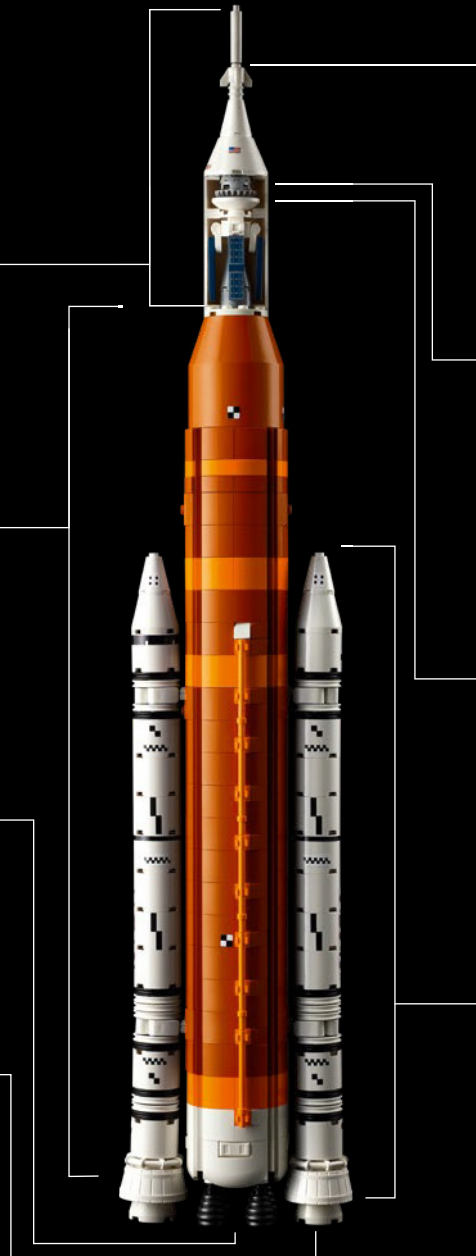

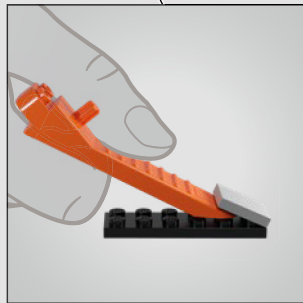
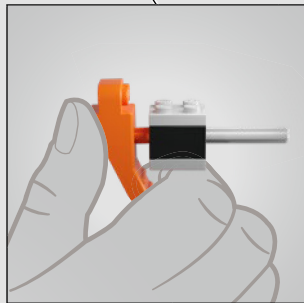
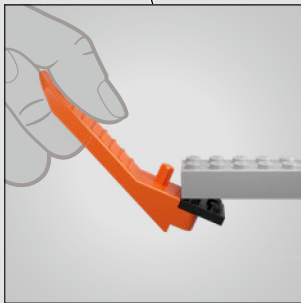
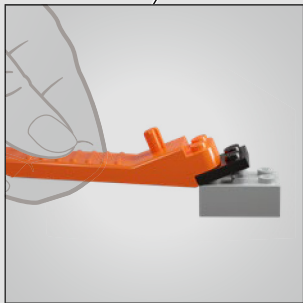
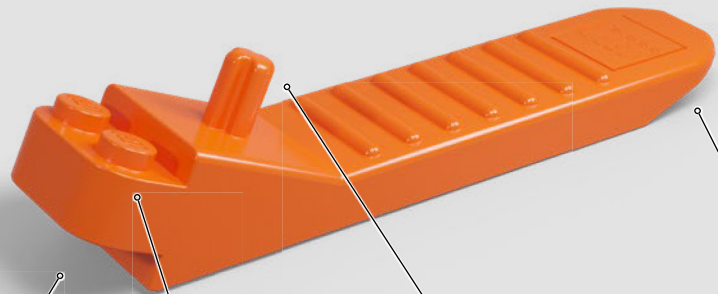

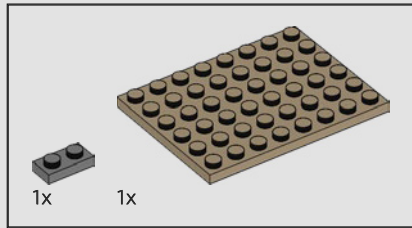

1

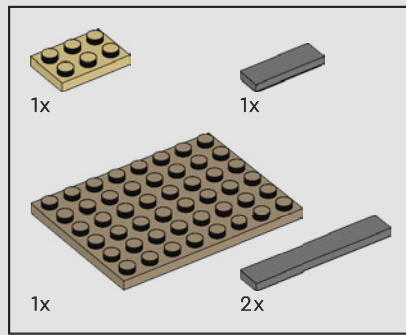
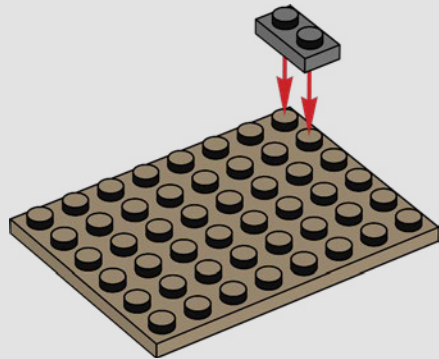

2

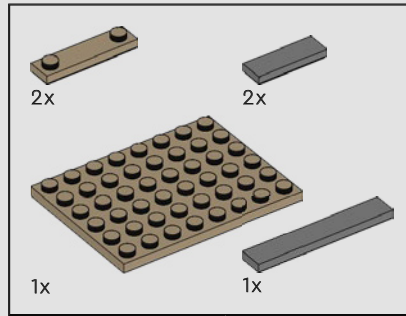
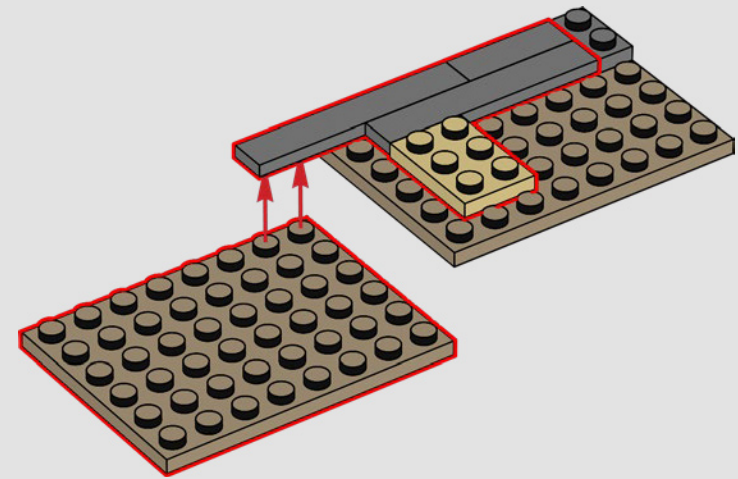

3

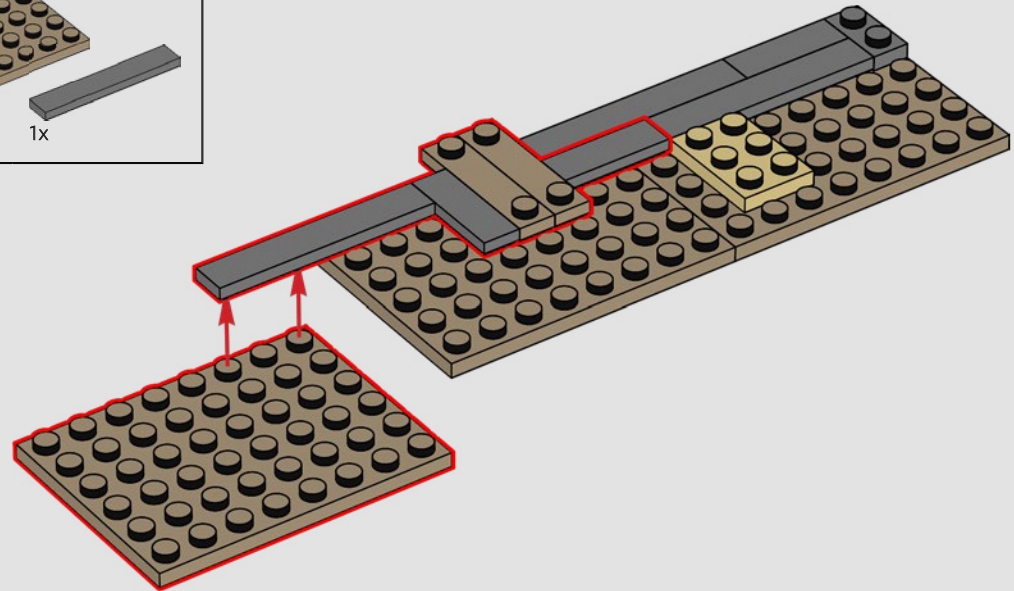

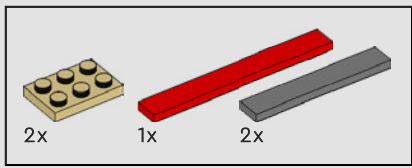

4

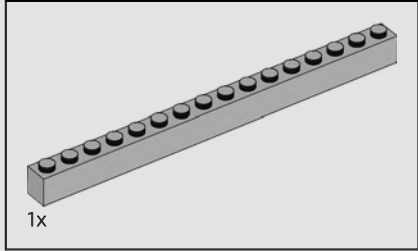
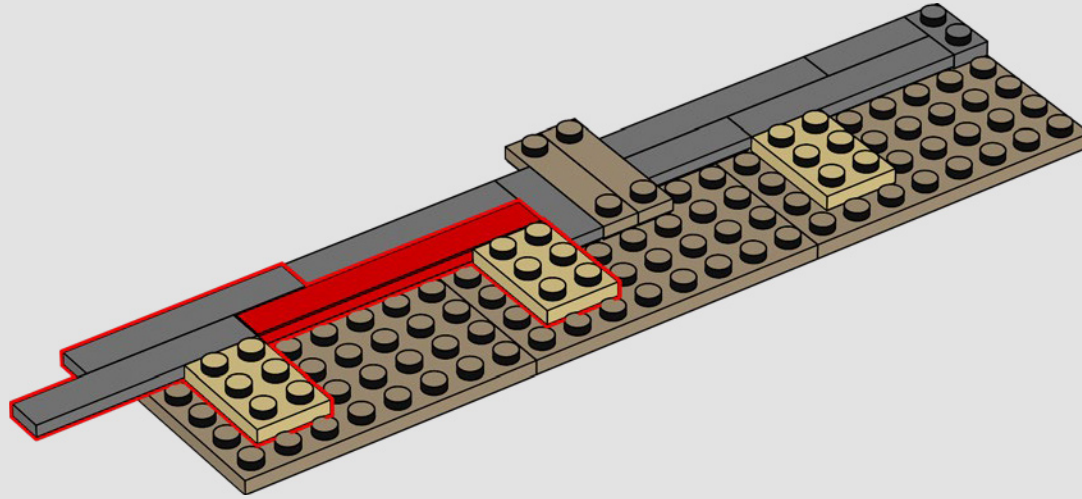

5

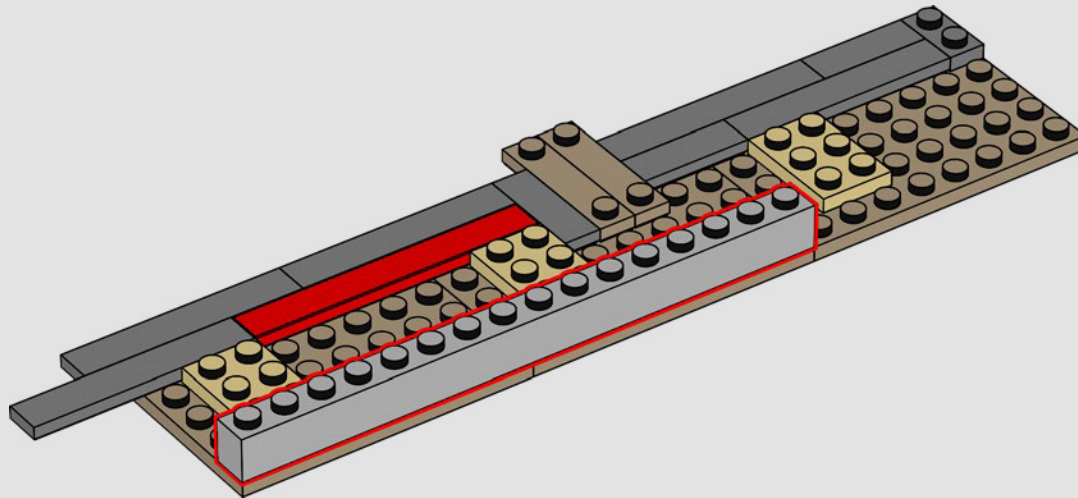

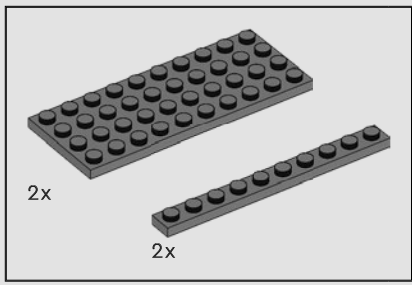

8

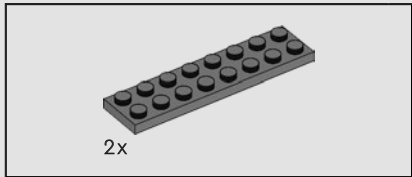
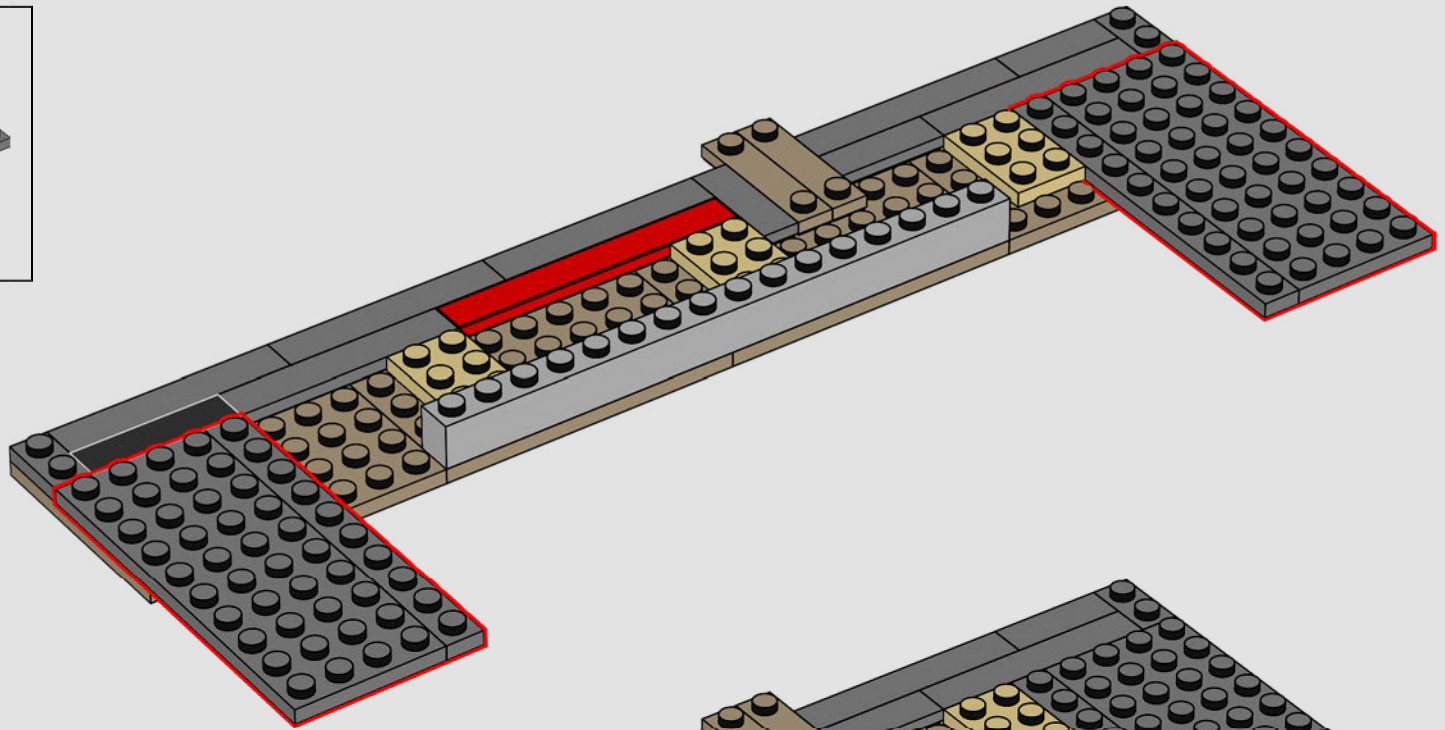

9

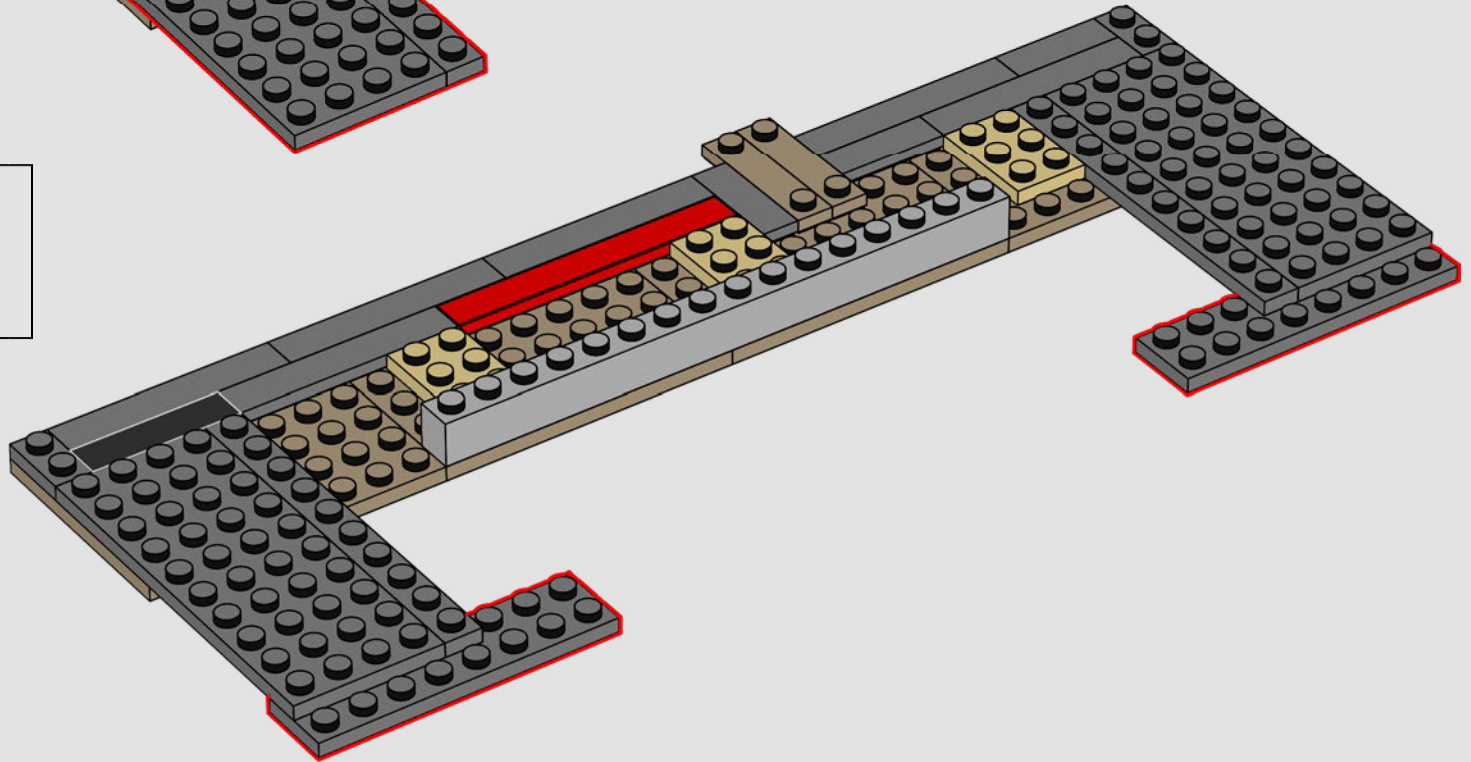

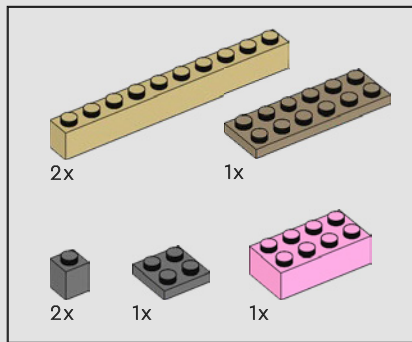

10

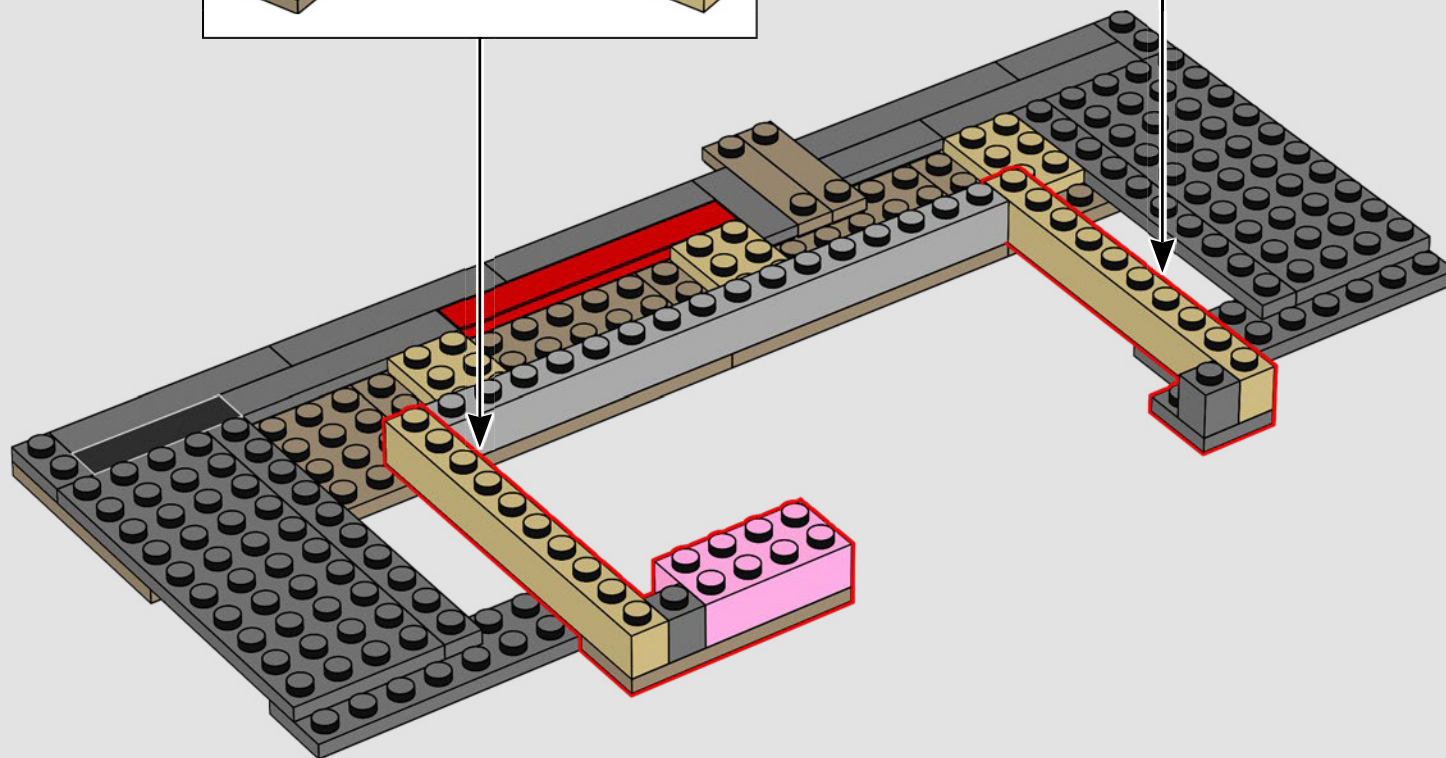
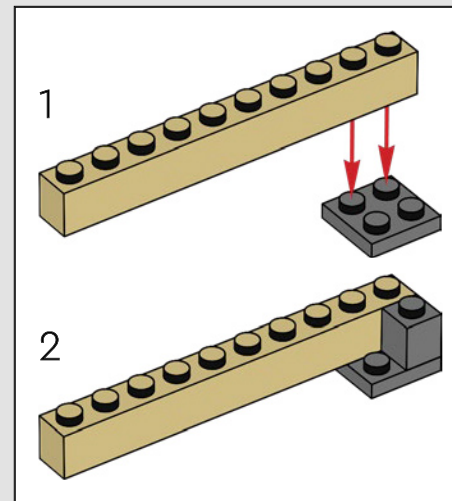
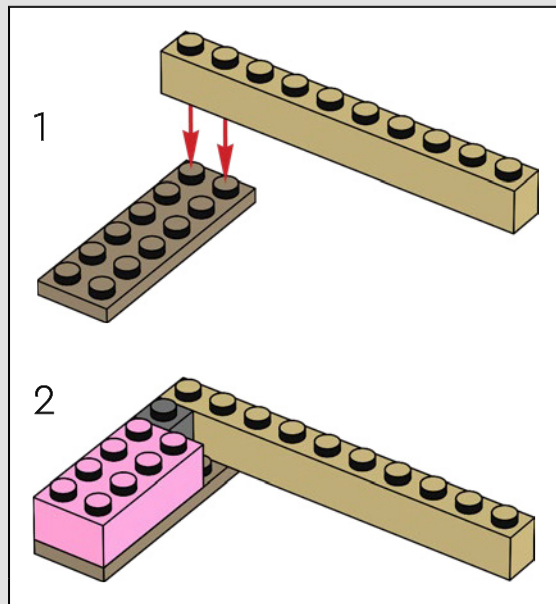

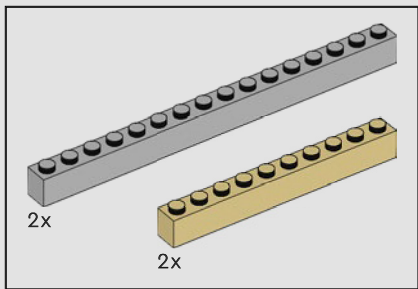

11

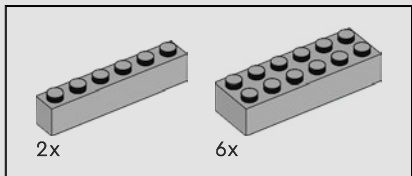
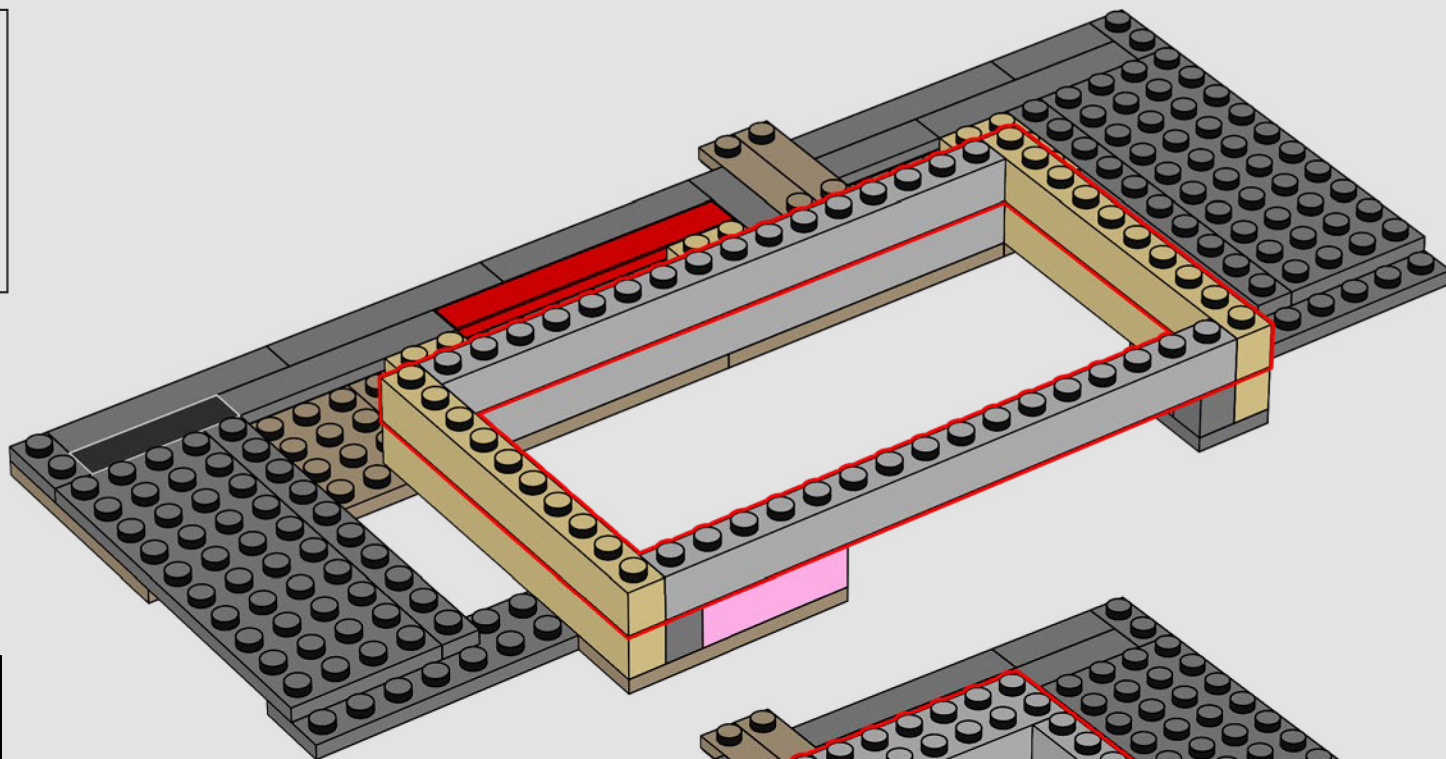

12

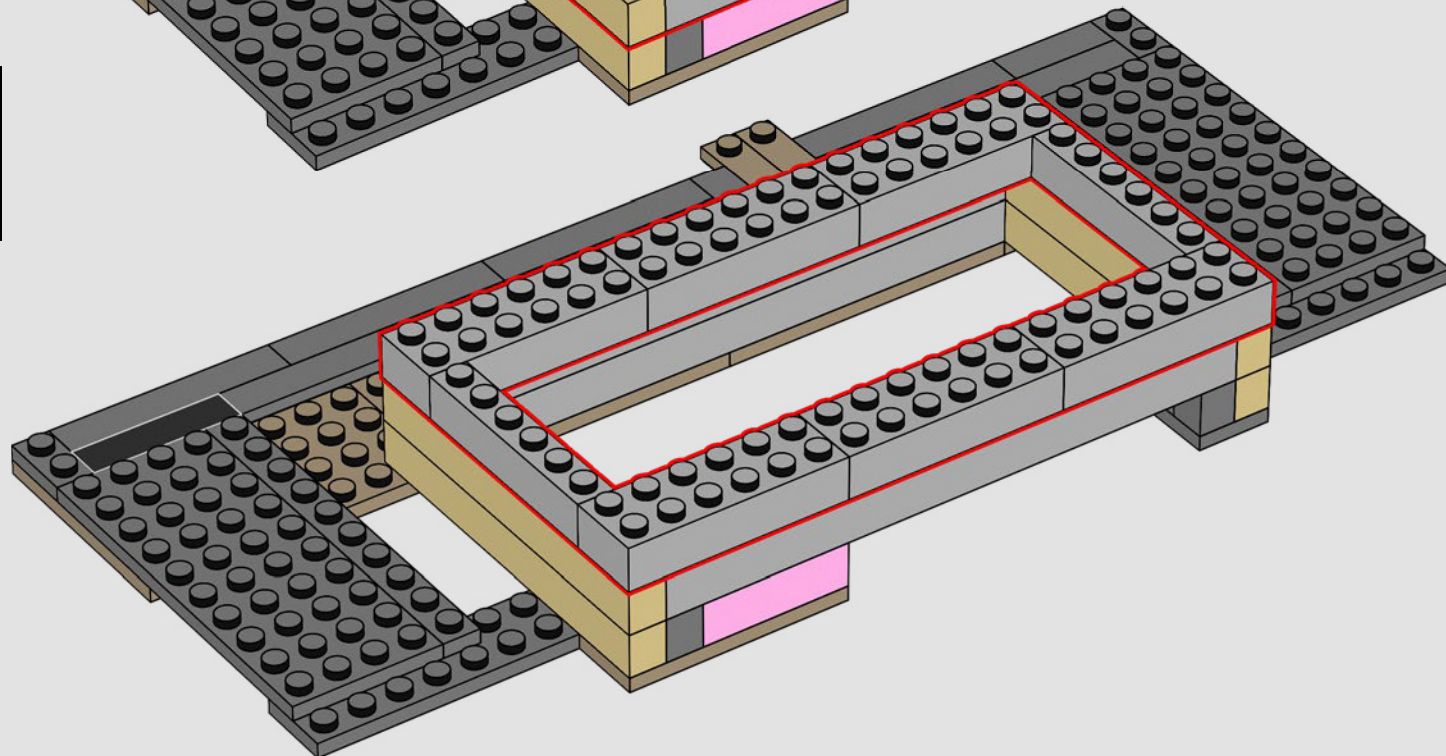

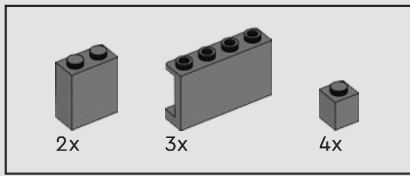

13

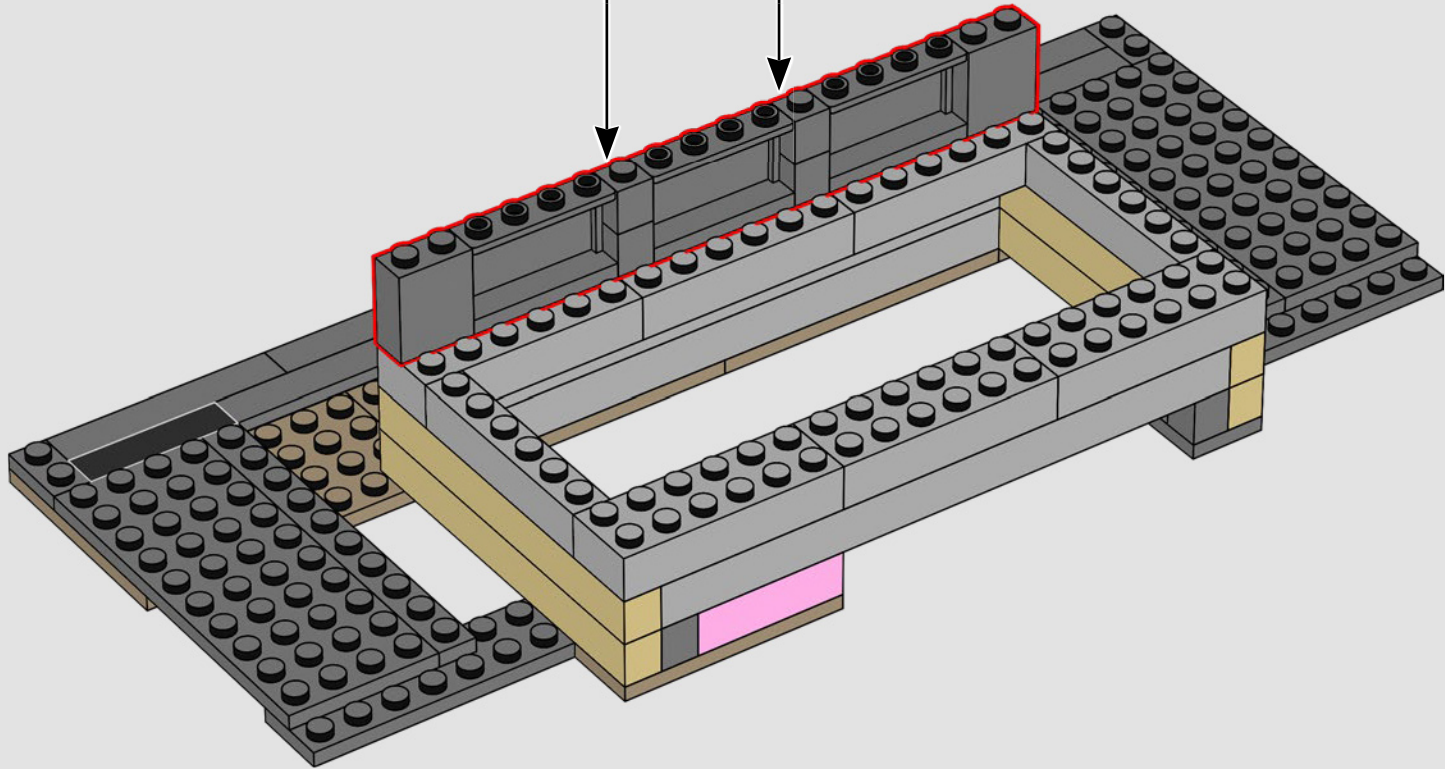
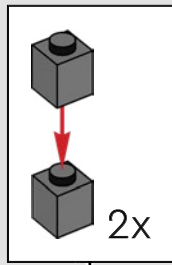

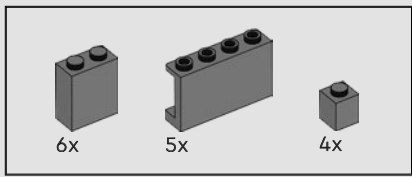

14

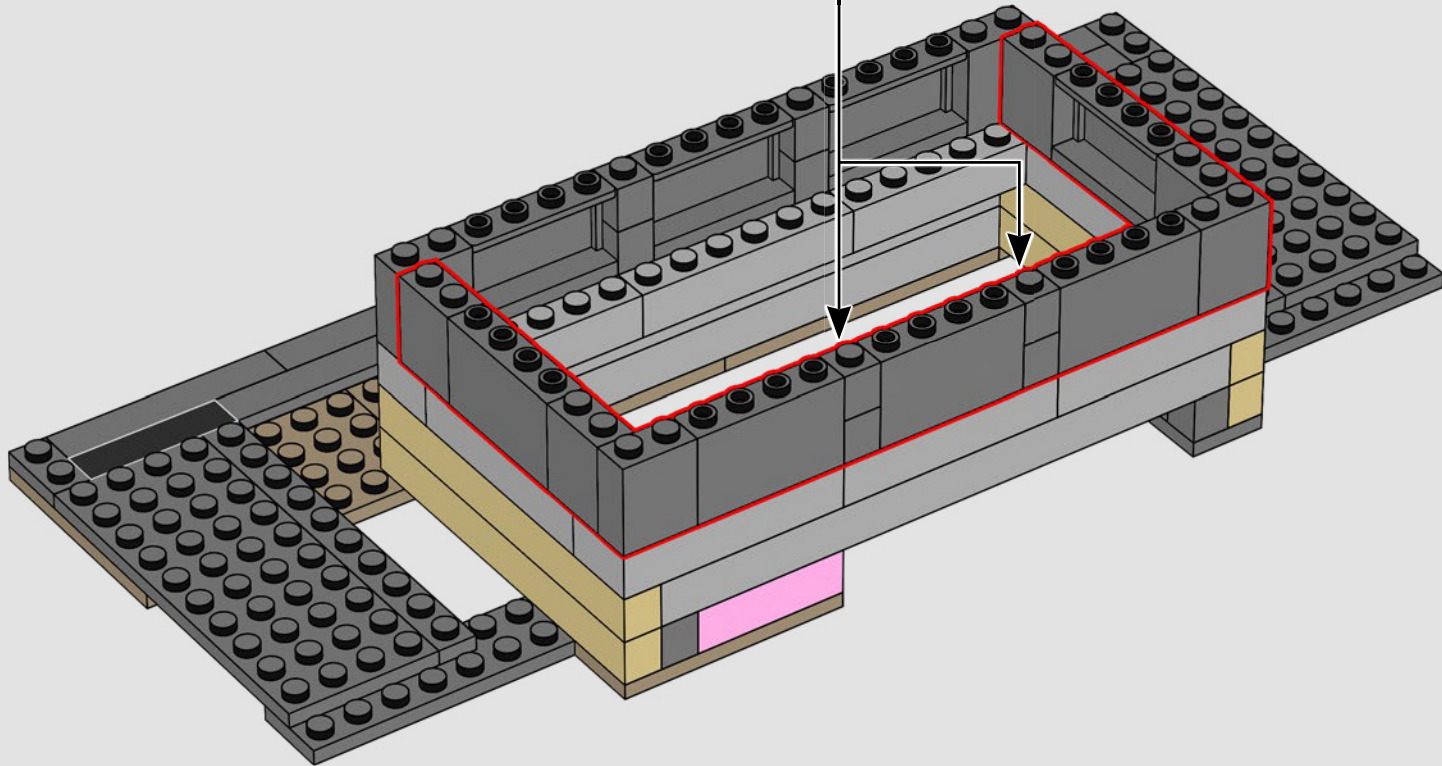
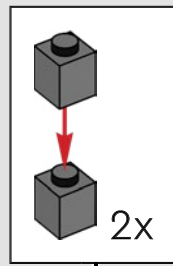

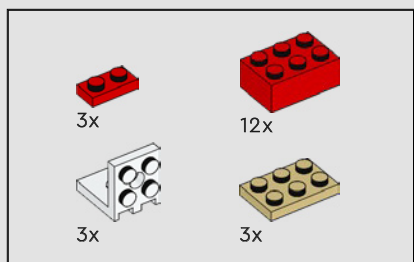

16

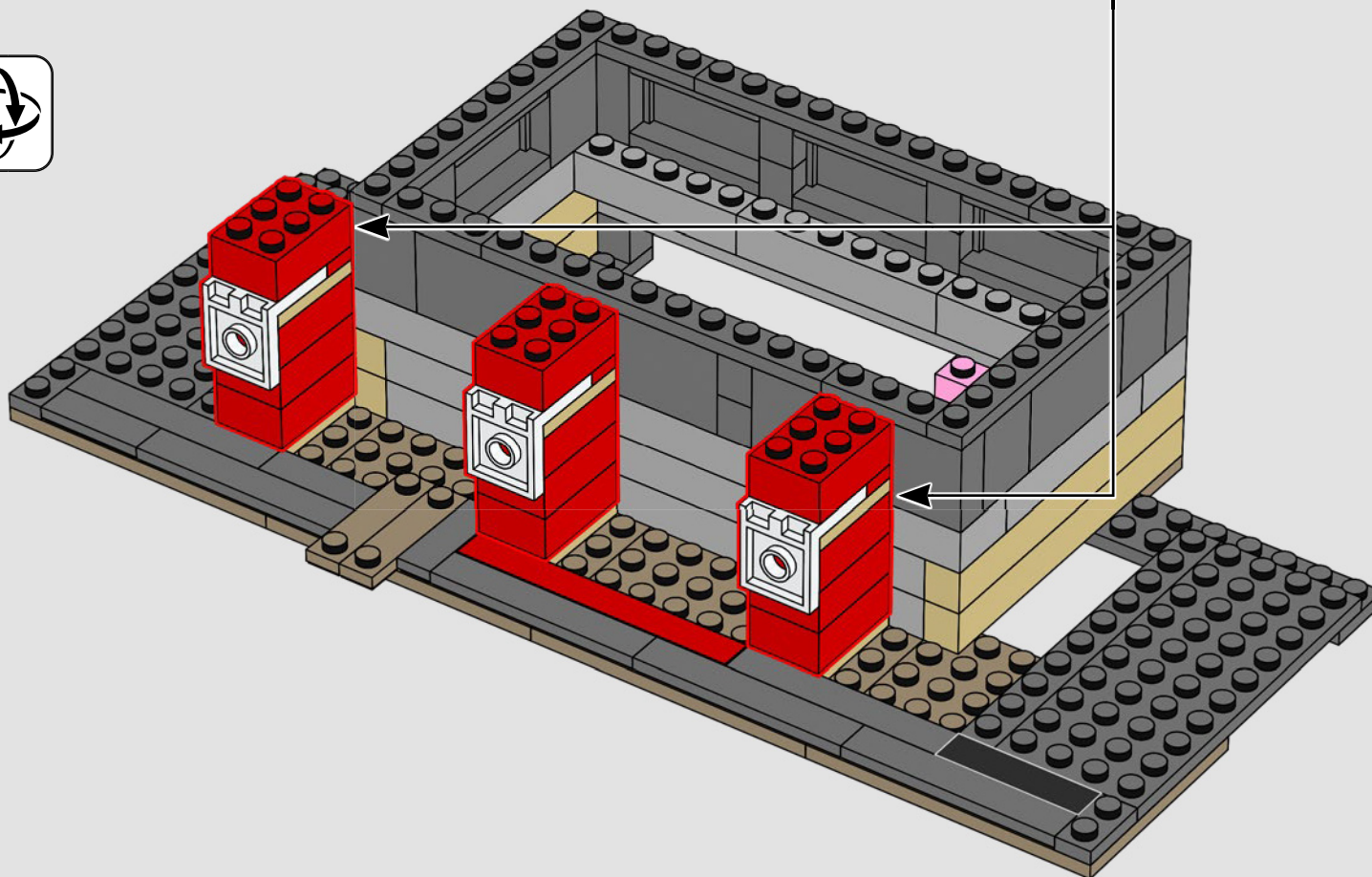
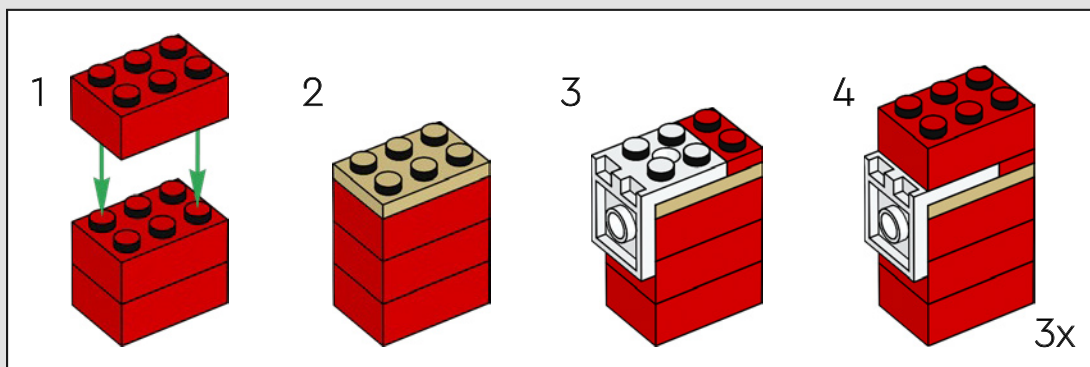

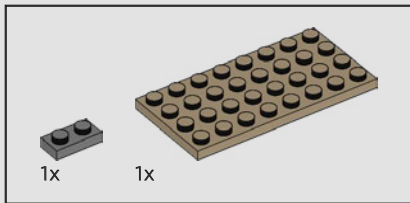
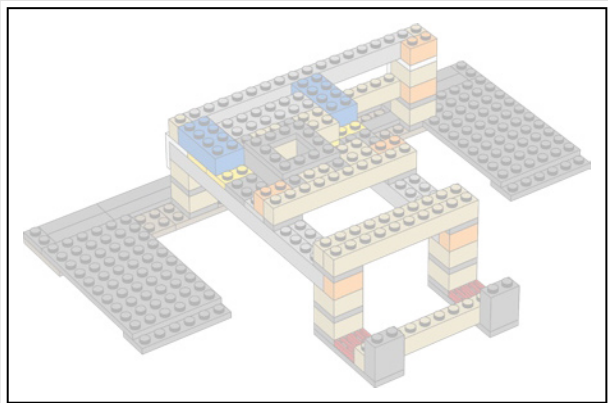

17

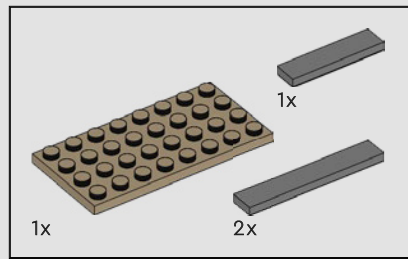
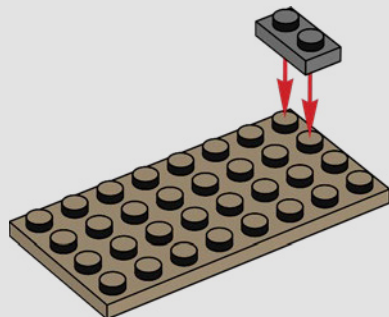

18

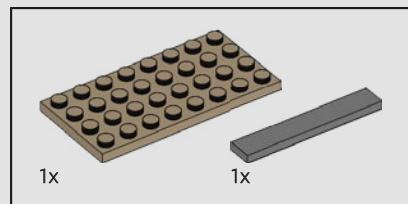
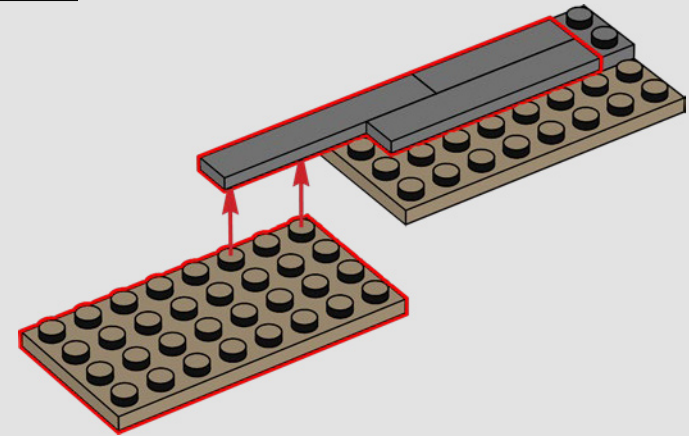

19

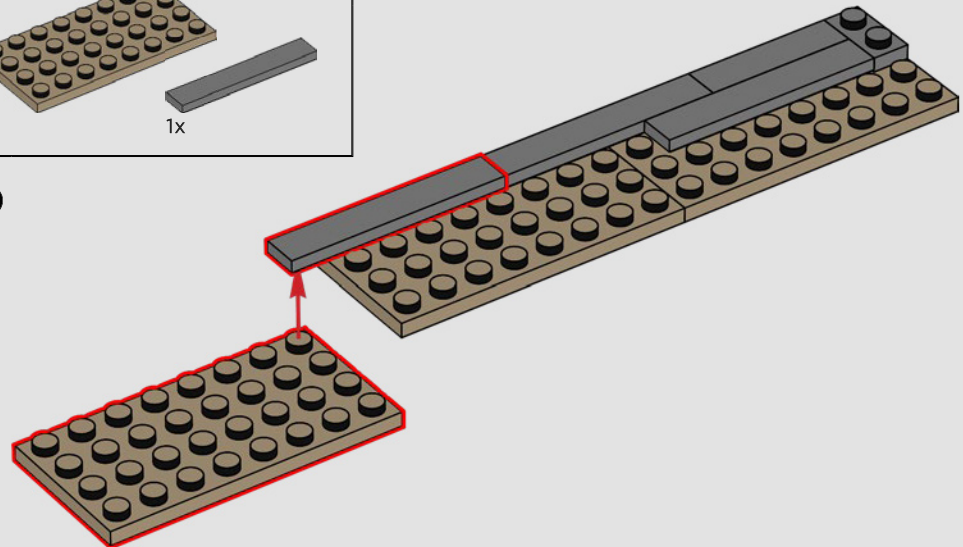

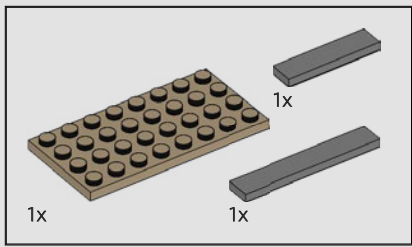

20

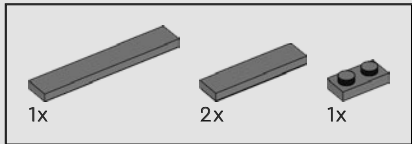
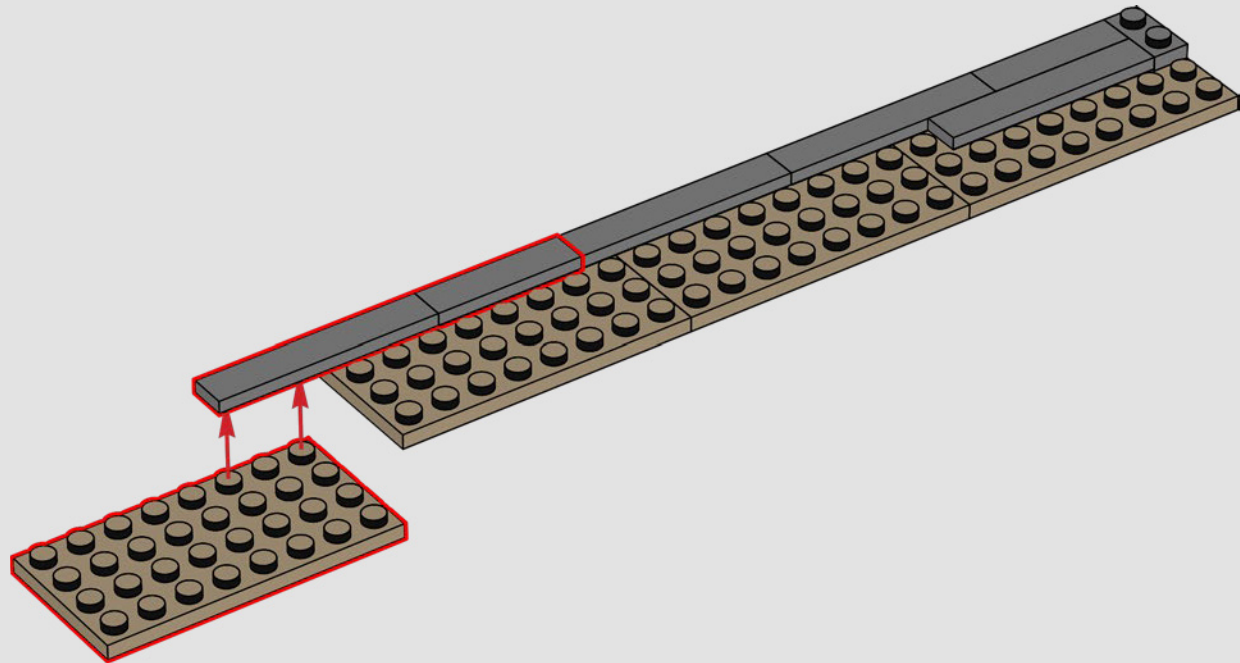

21

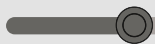
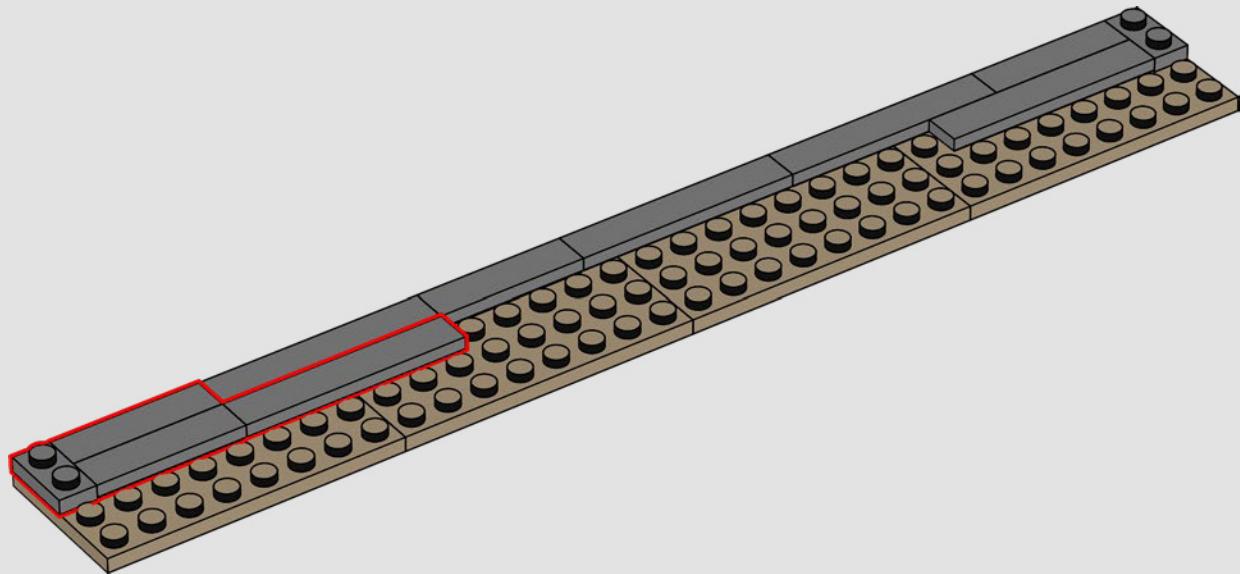

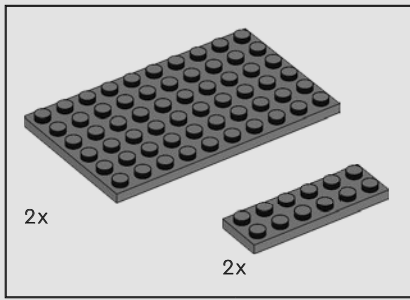

22

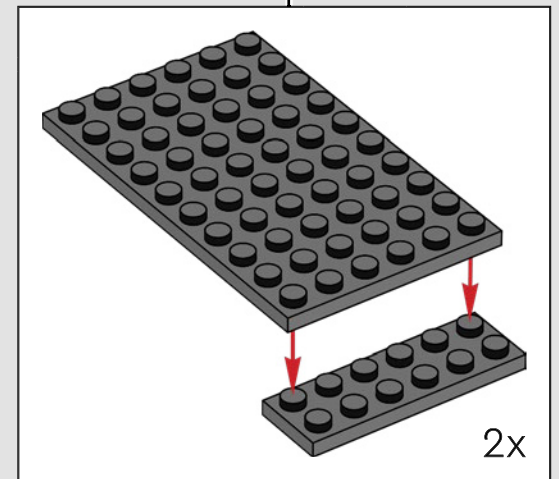
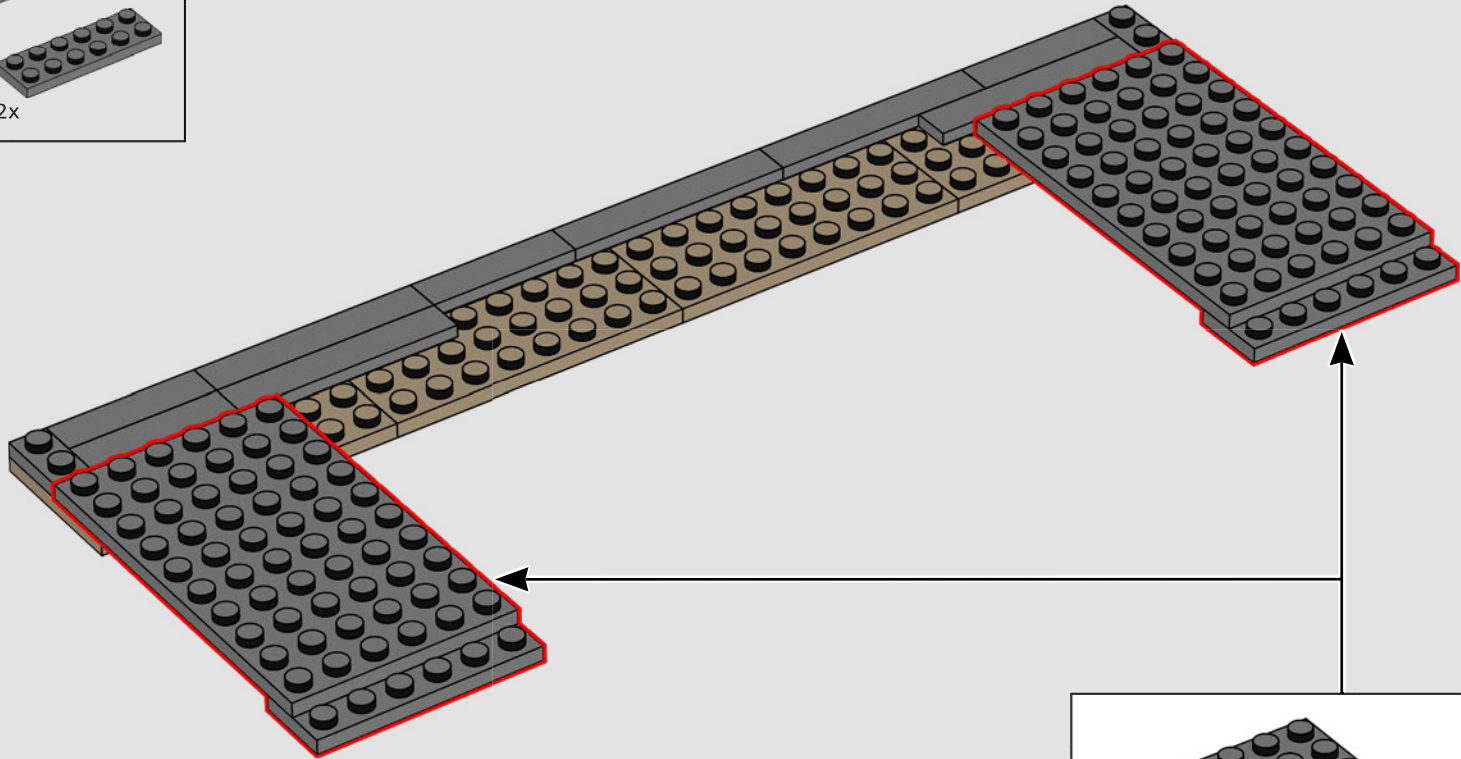

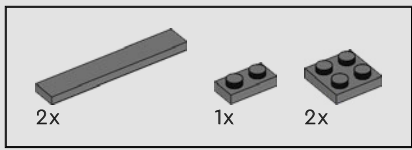

23

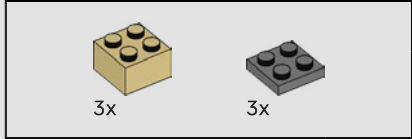
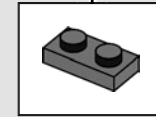
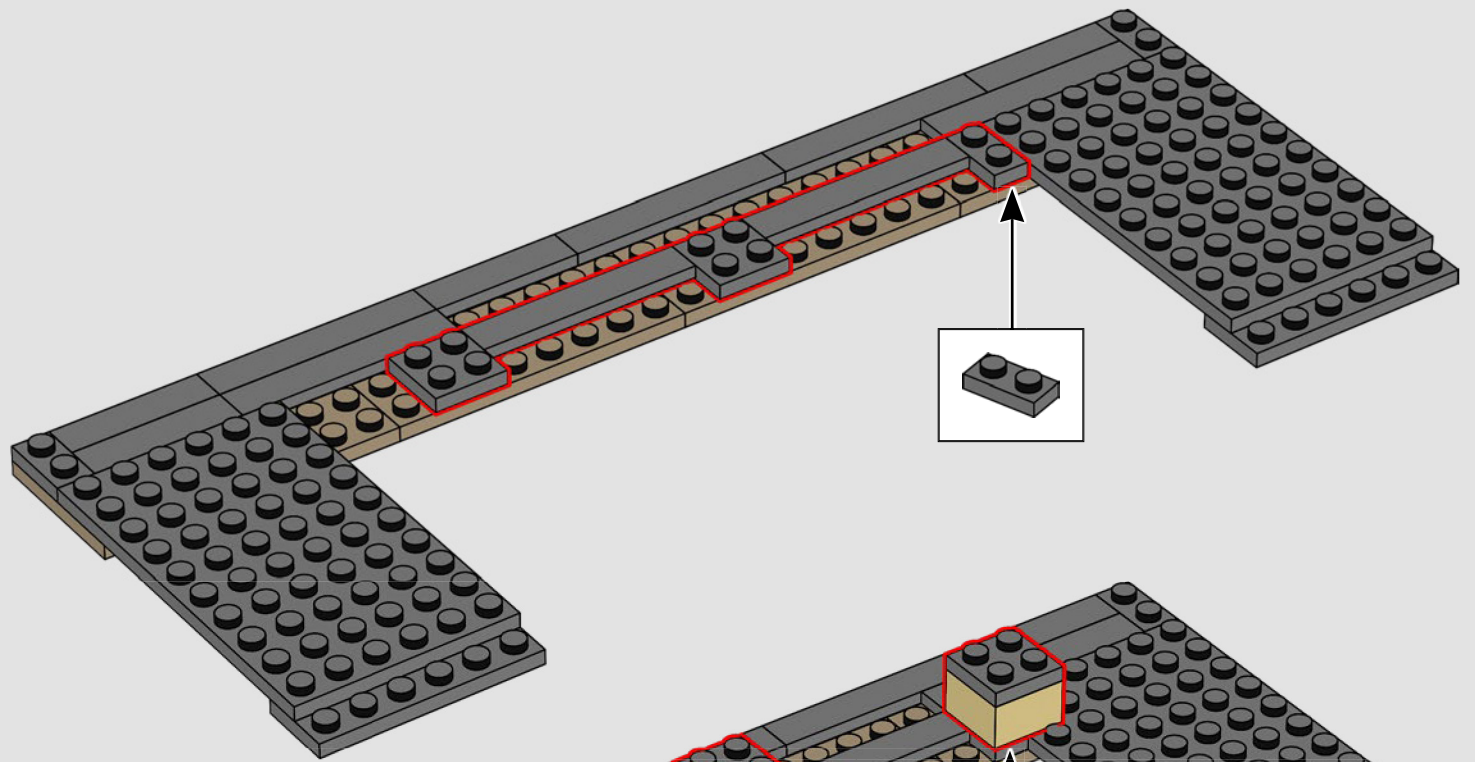

24

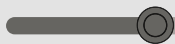
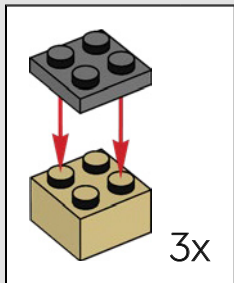
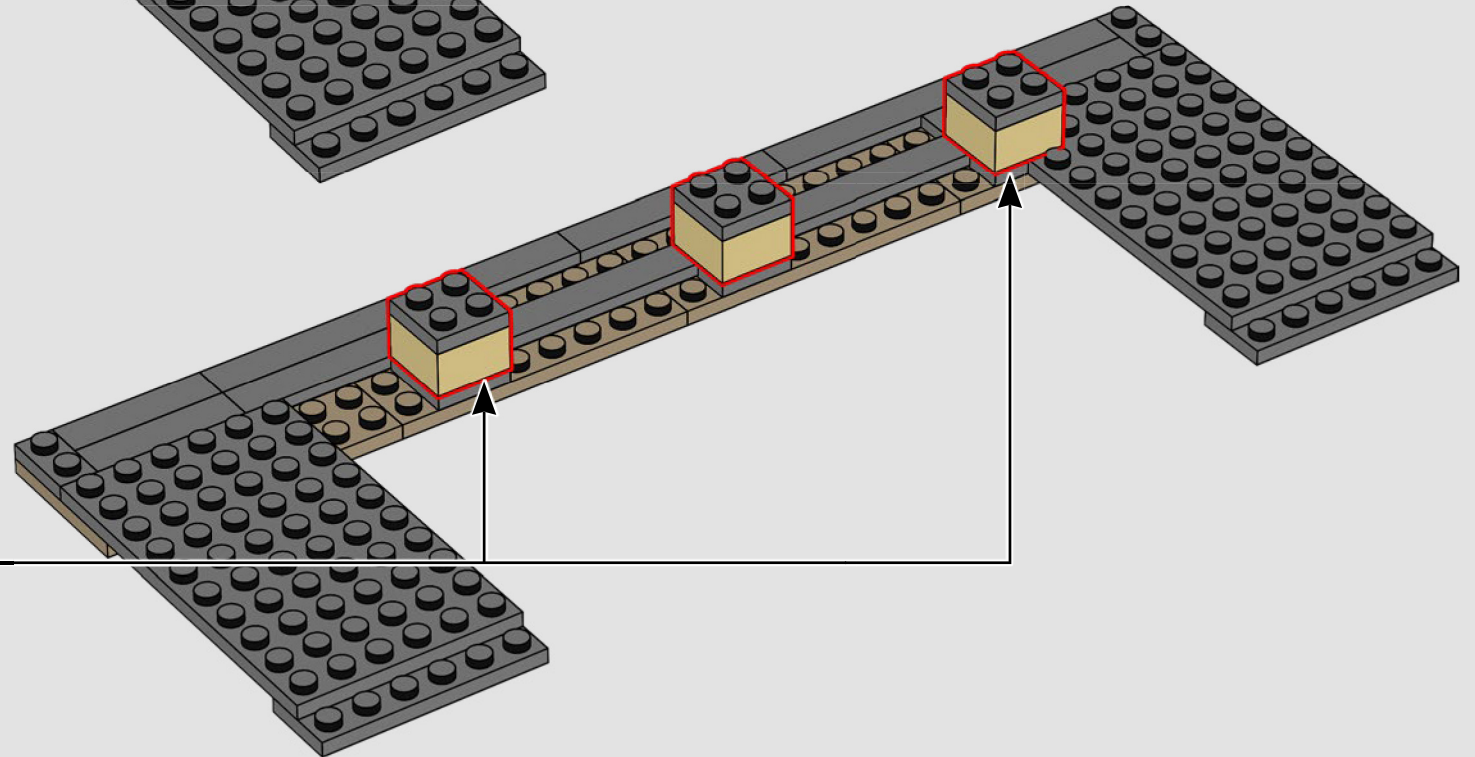

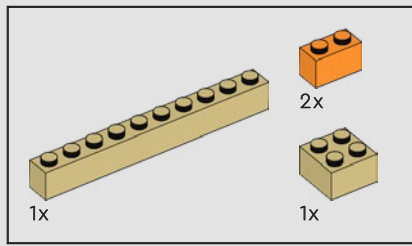

25

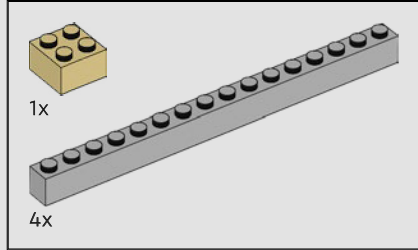
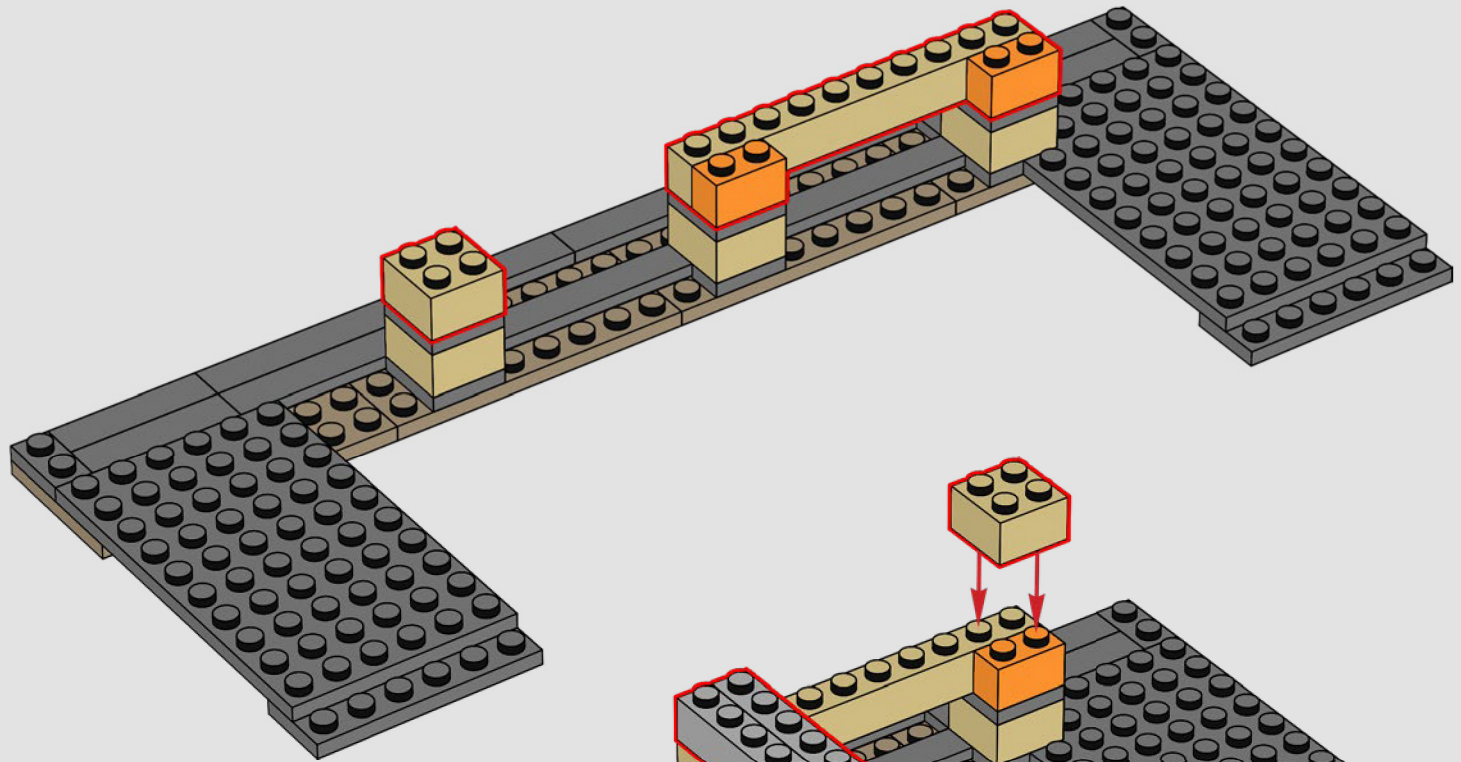

26

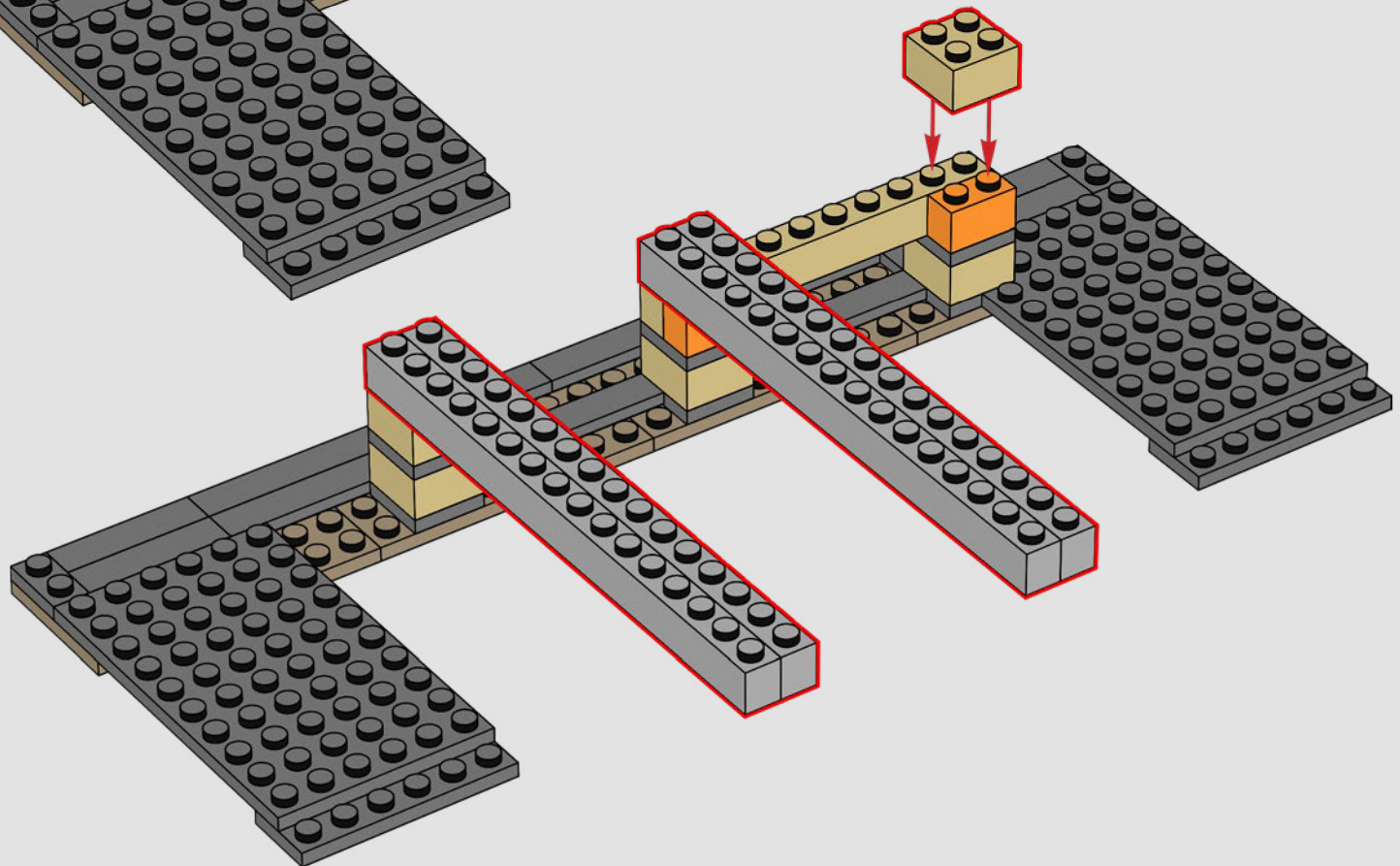

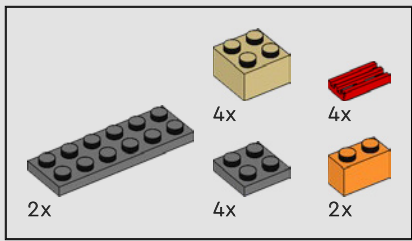

27

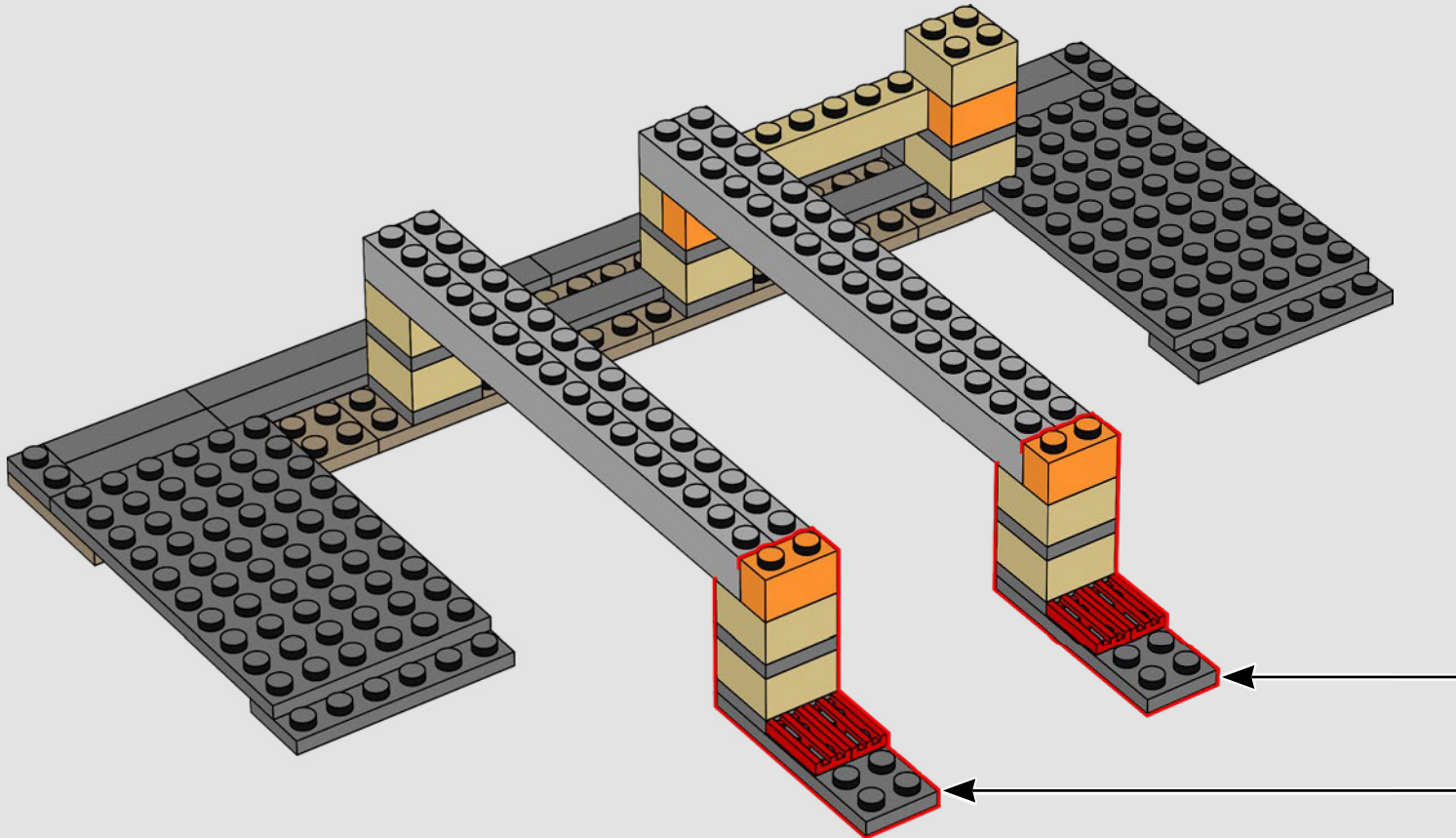
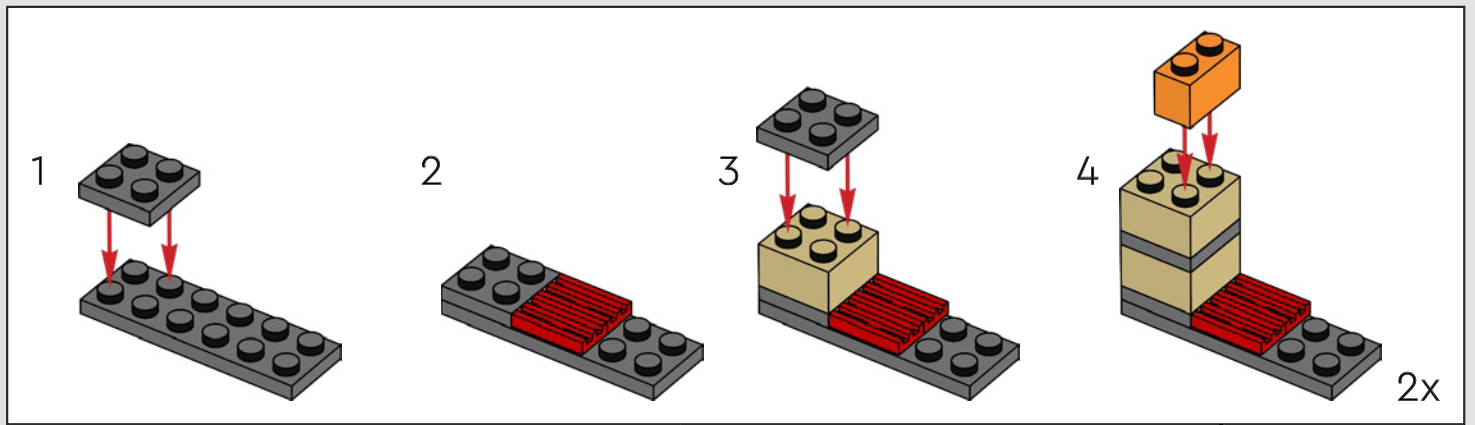

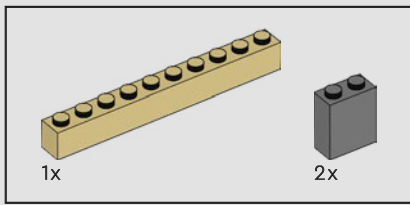

28

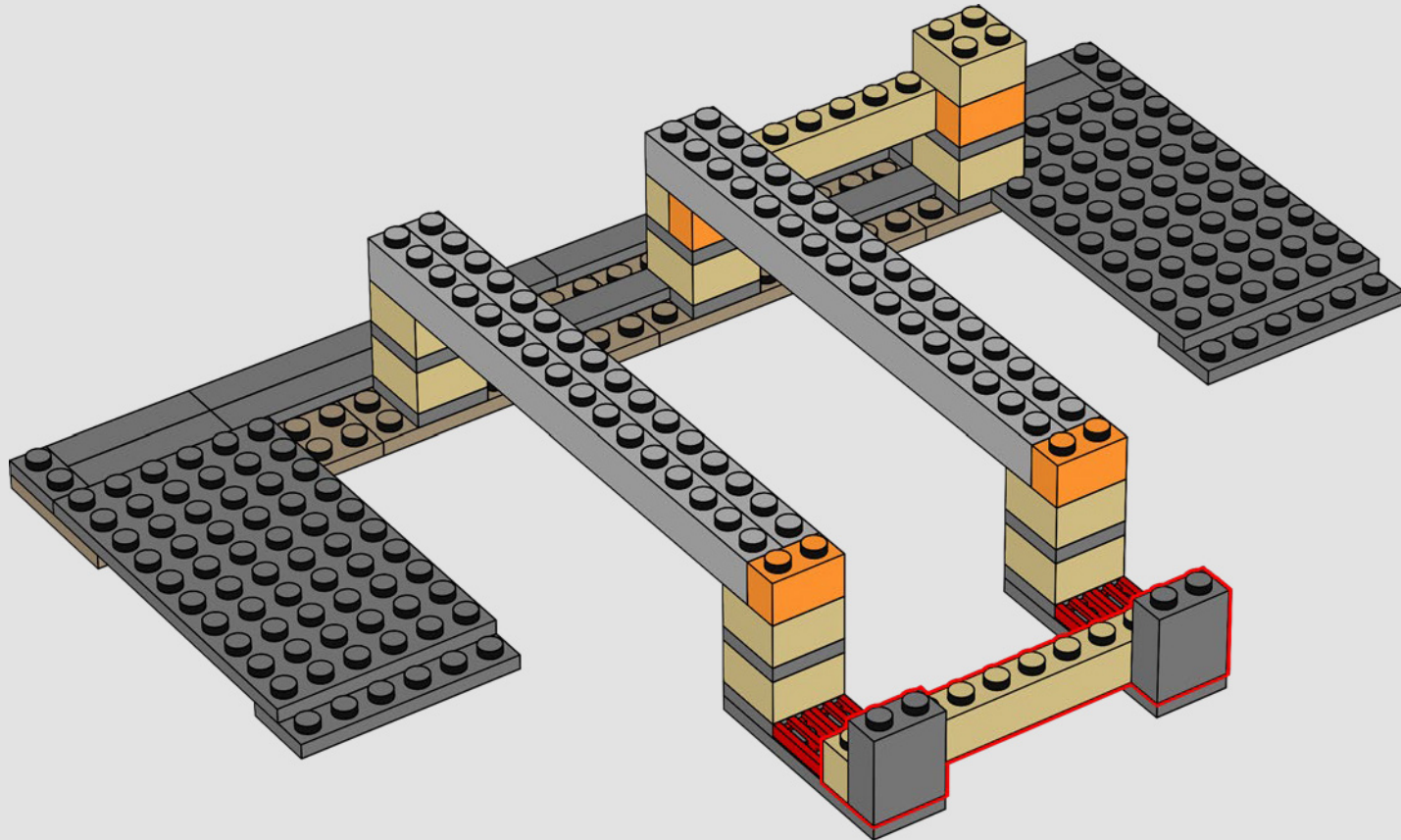

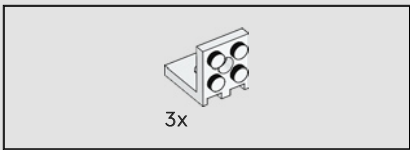

29

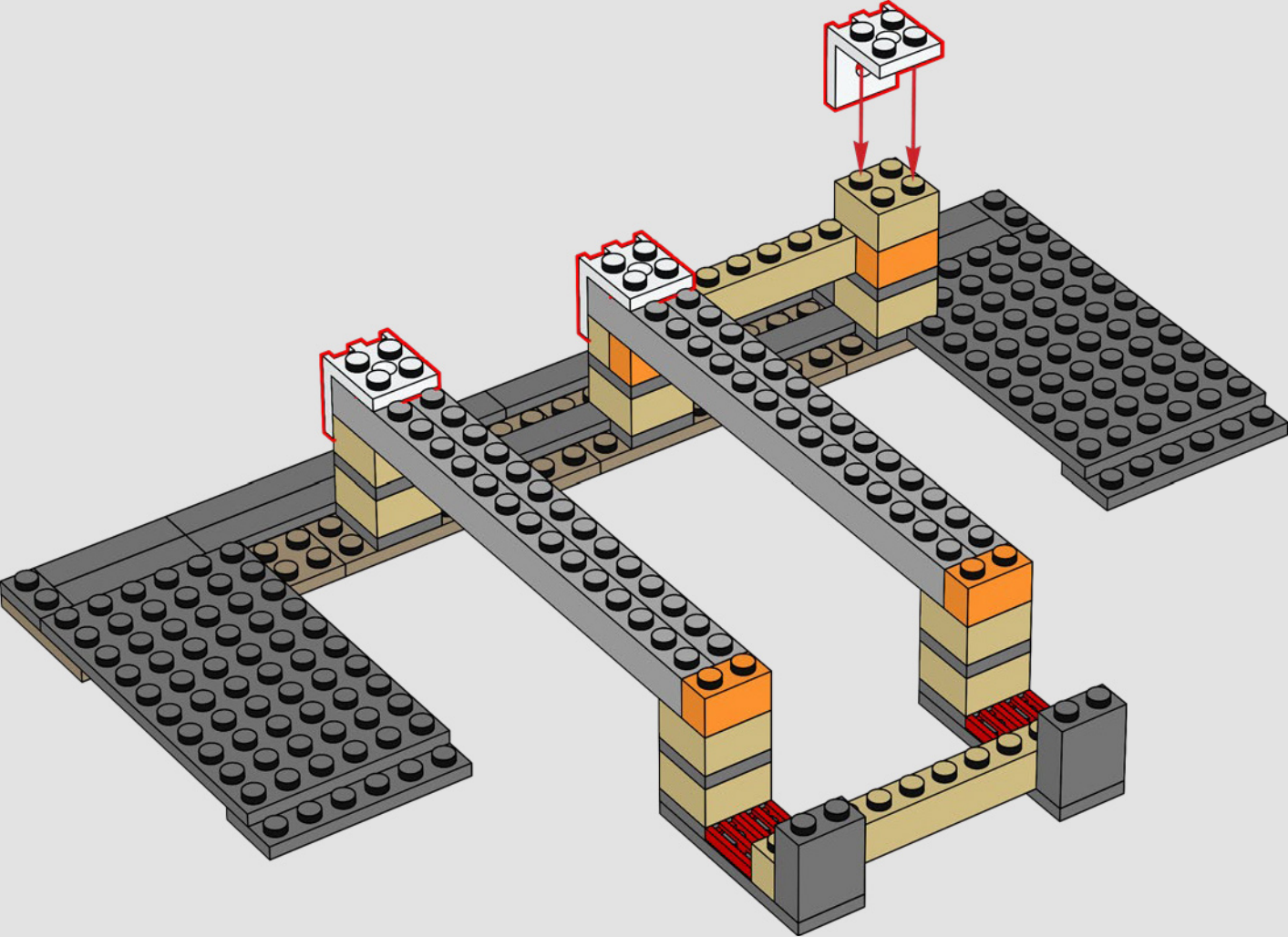

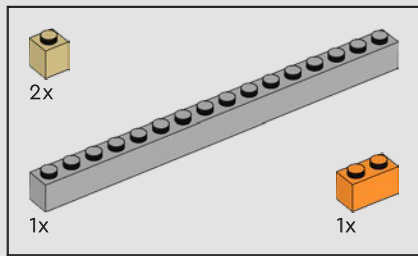

30

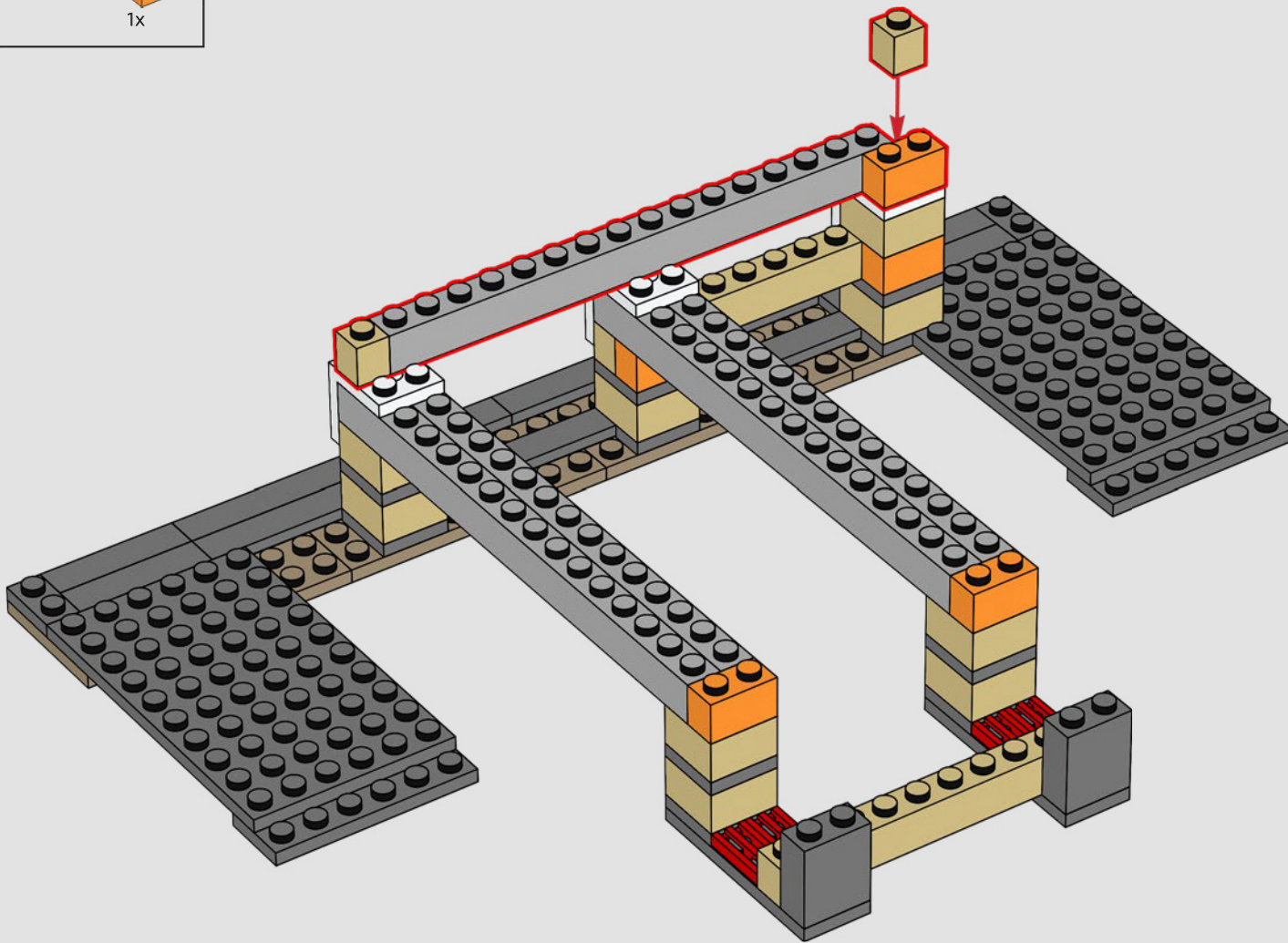

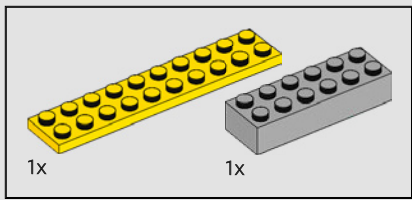

31

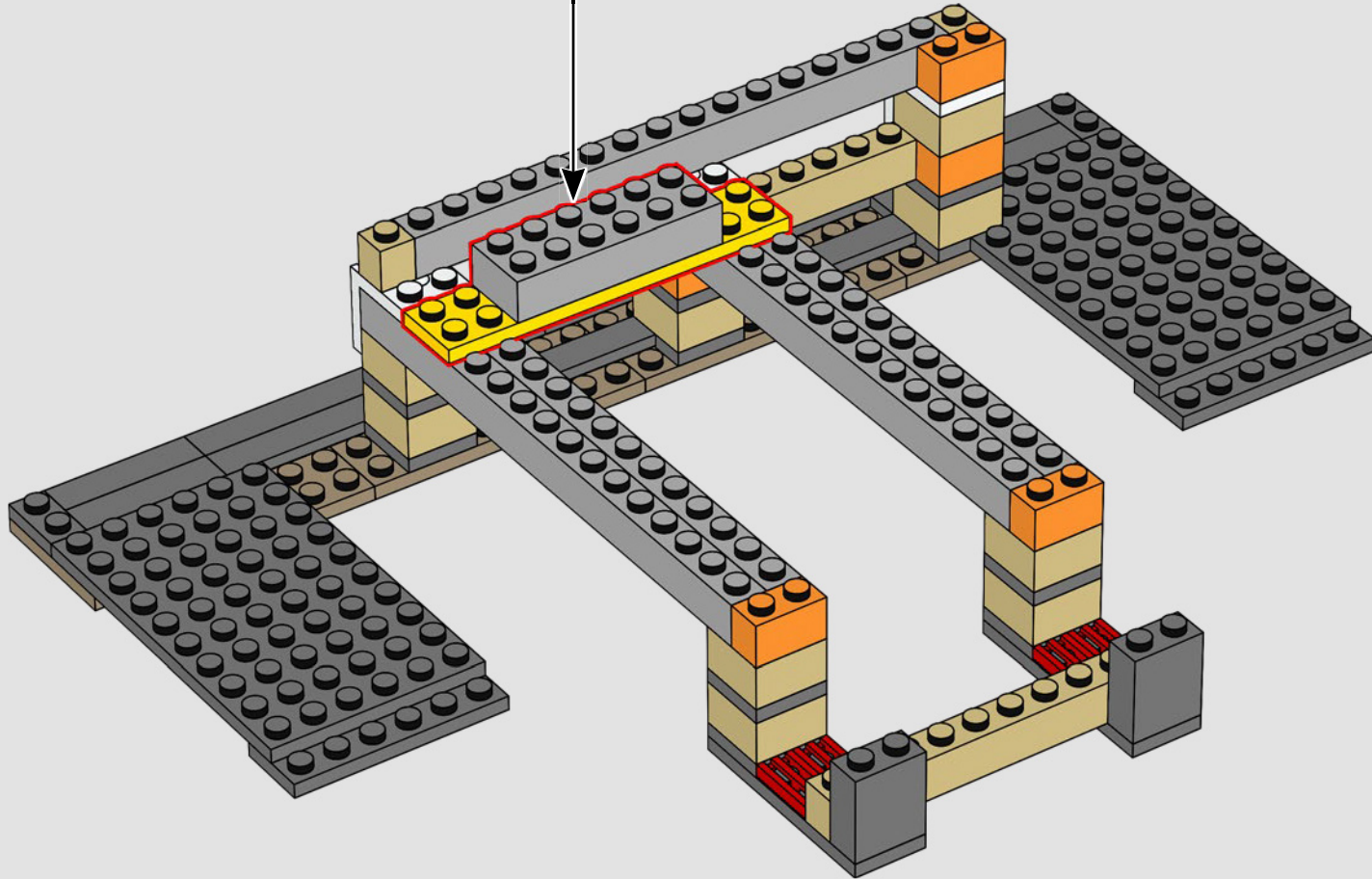
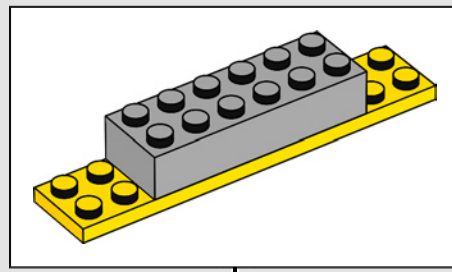

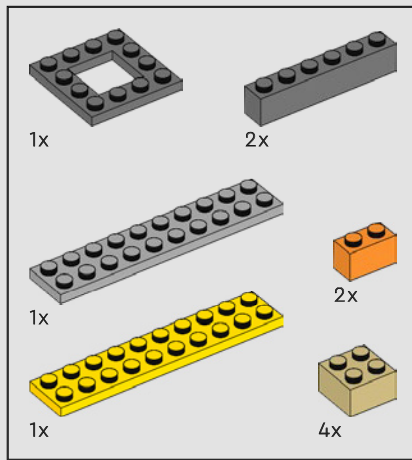

32

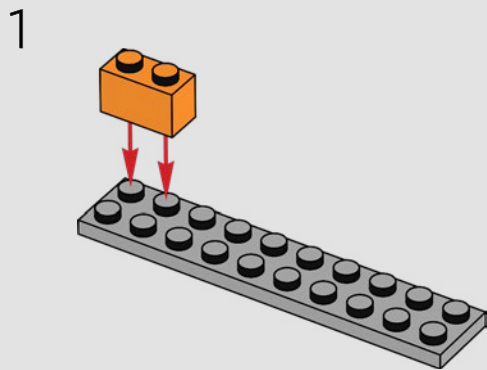

2

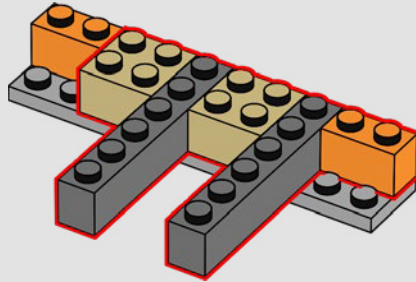

3

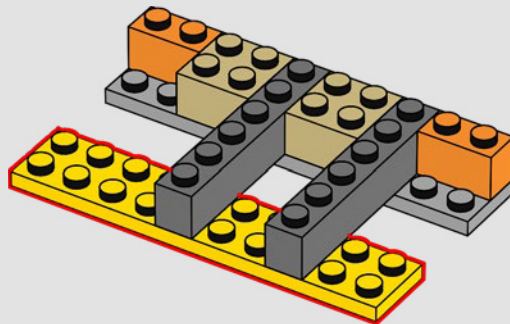

4

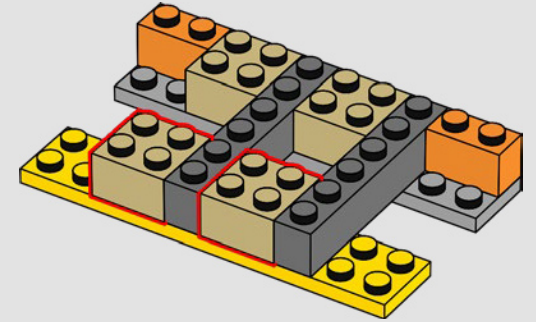

5

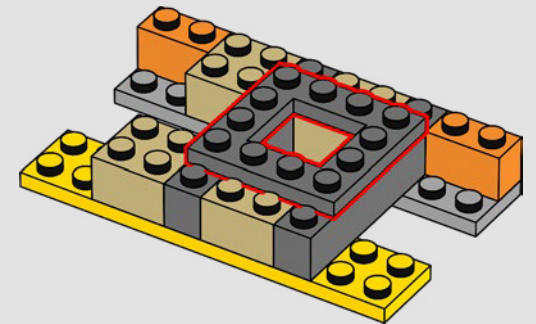

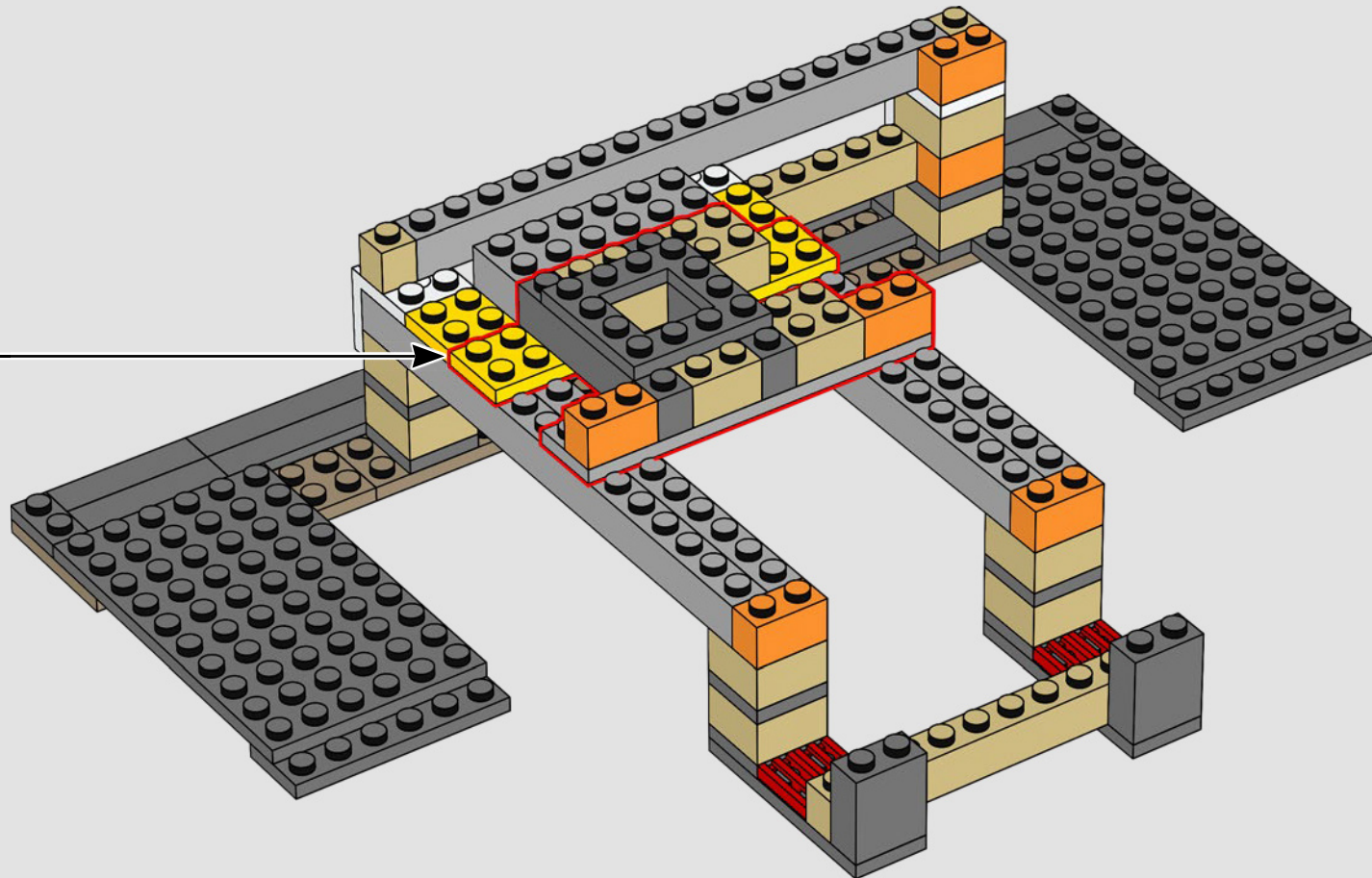

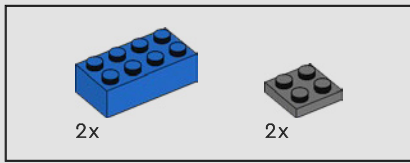

33

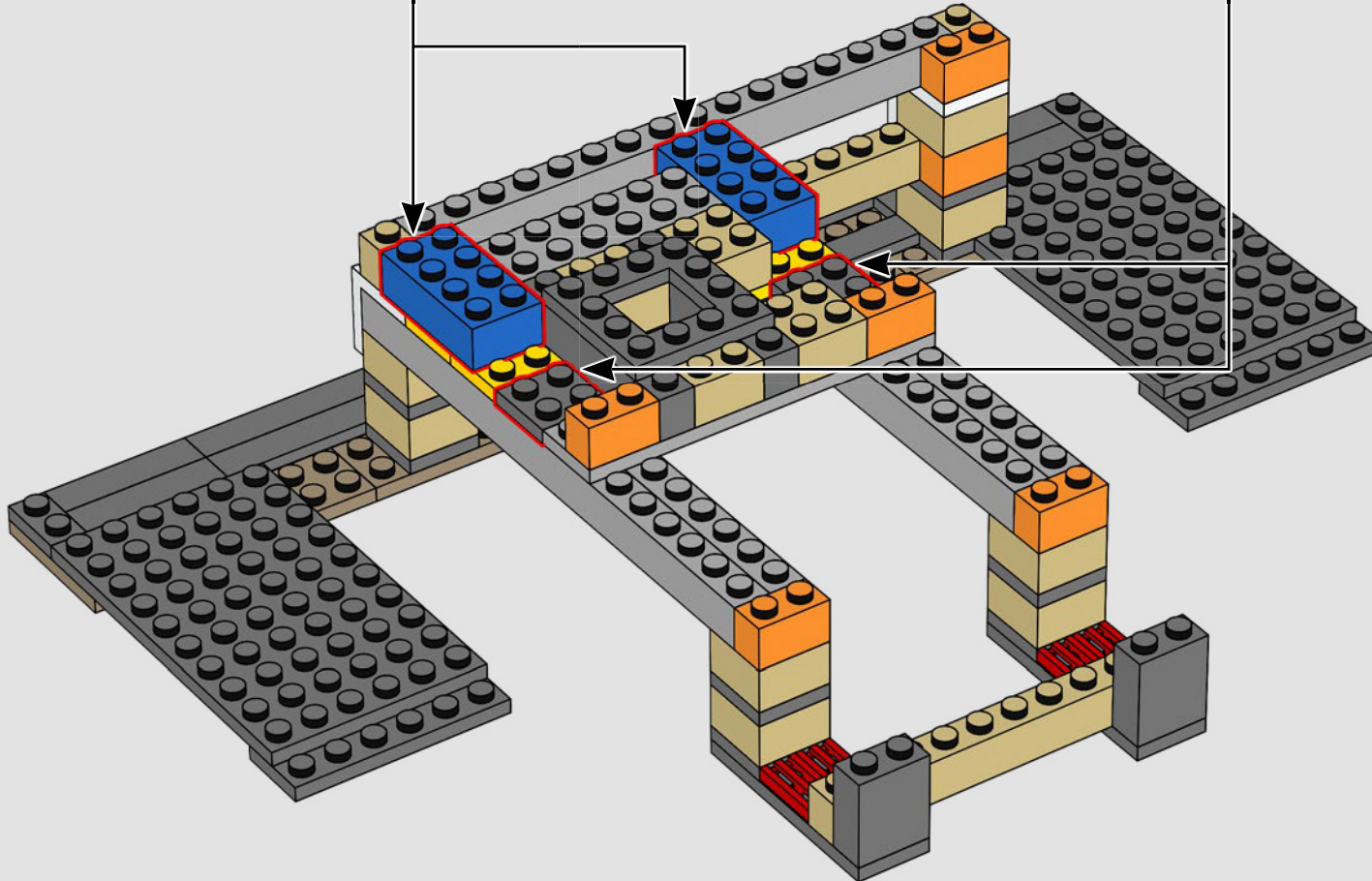
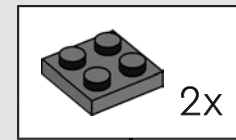
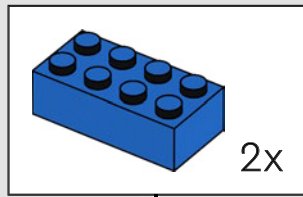

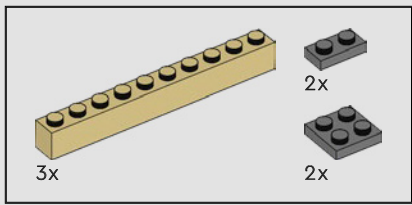

34

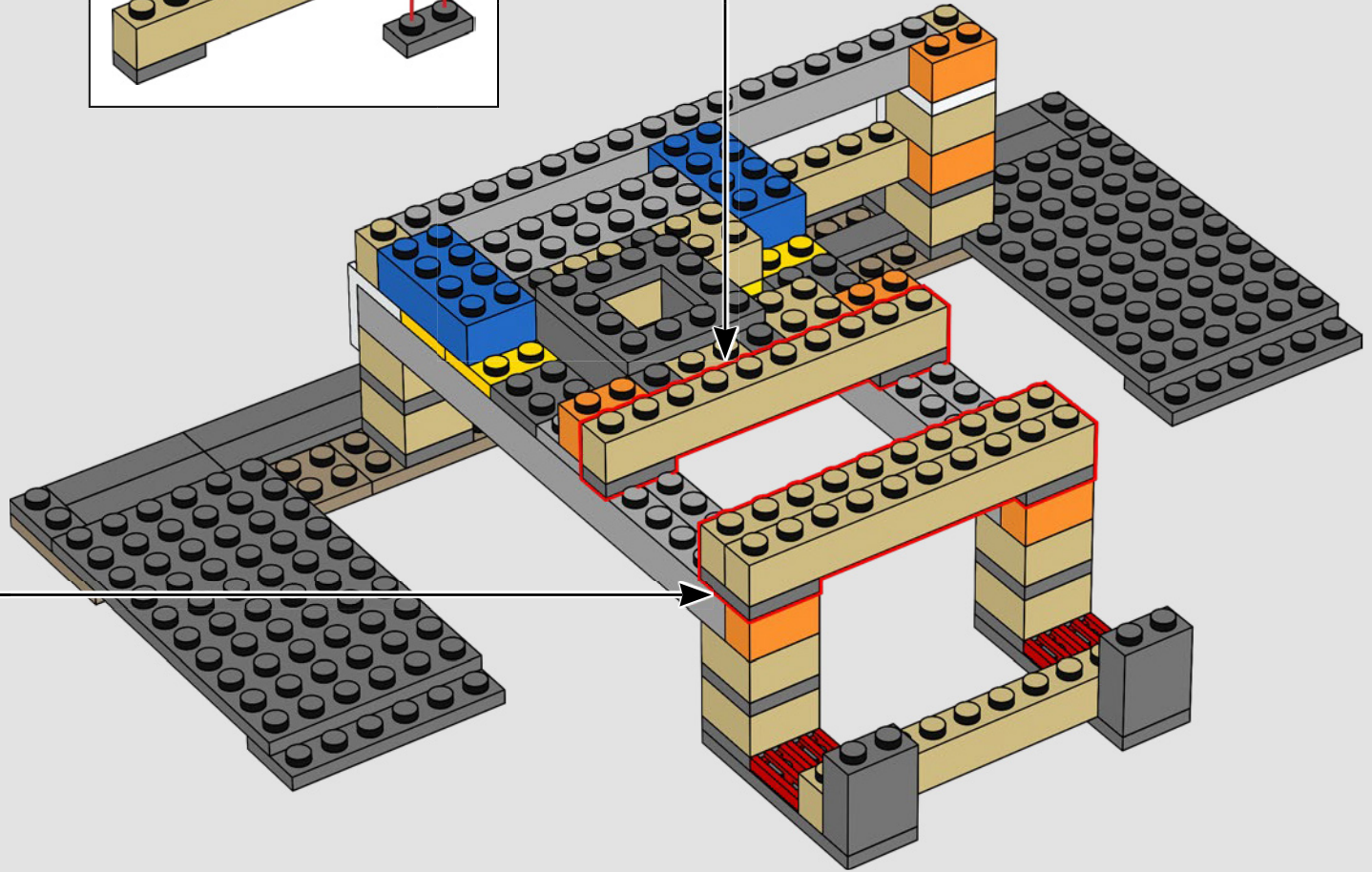
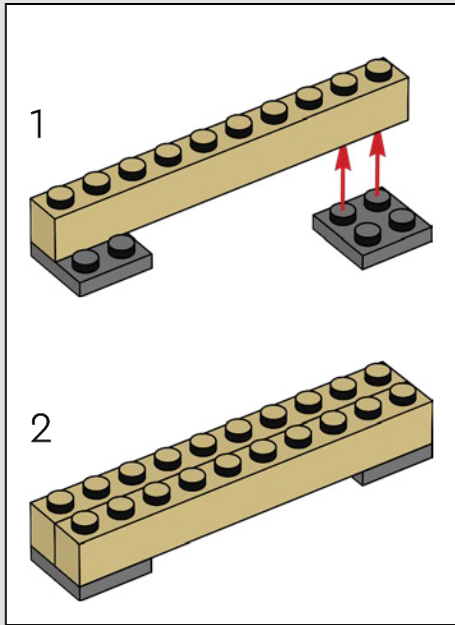
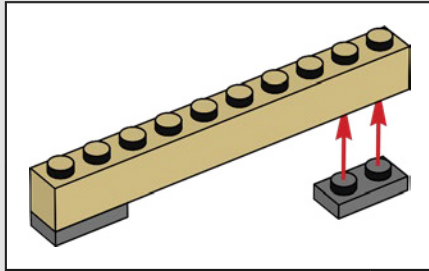

35

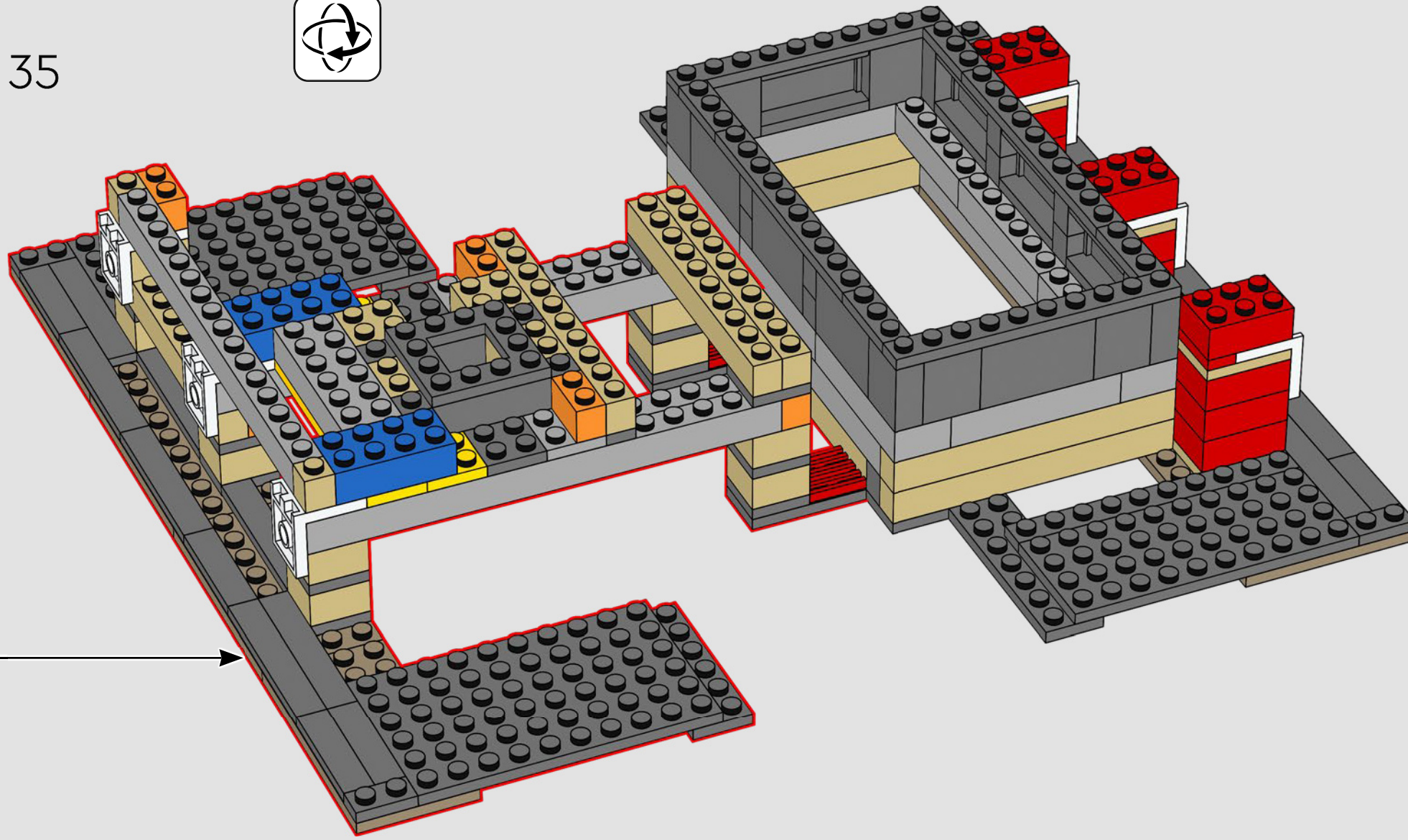
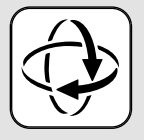

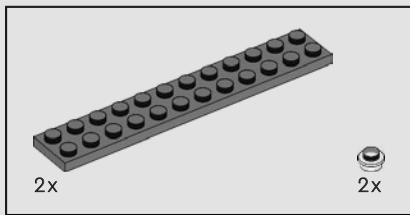

36

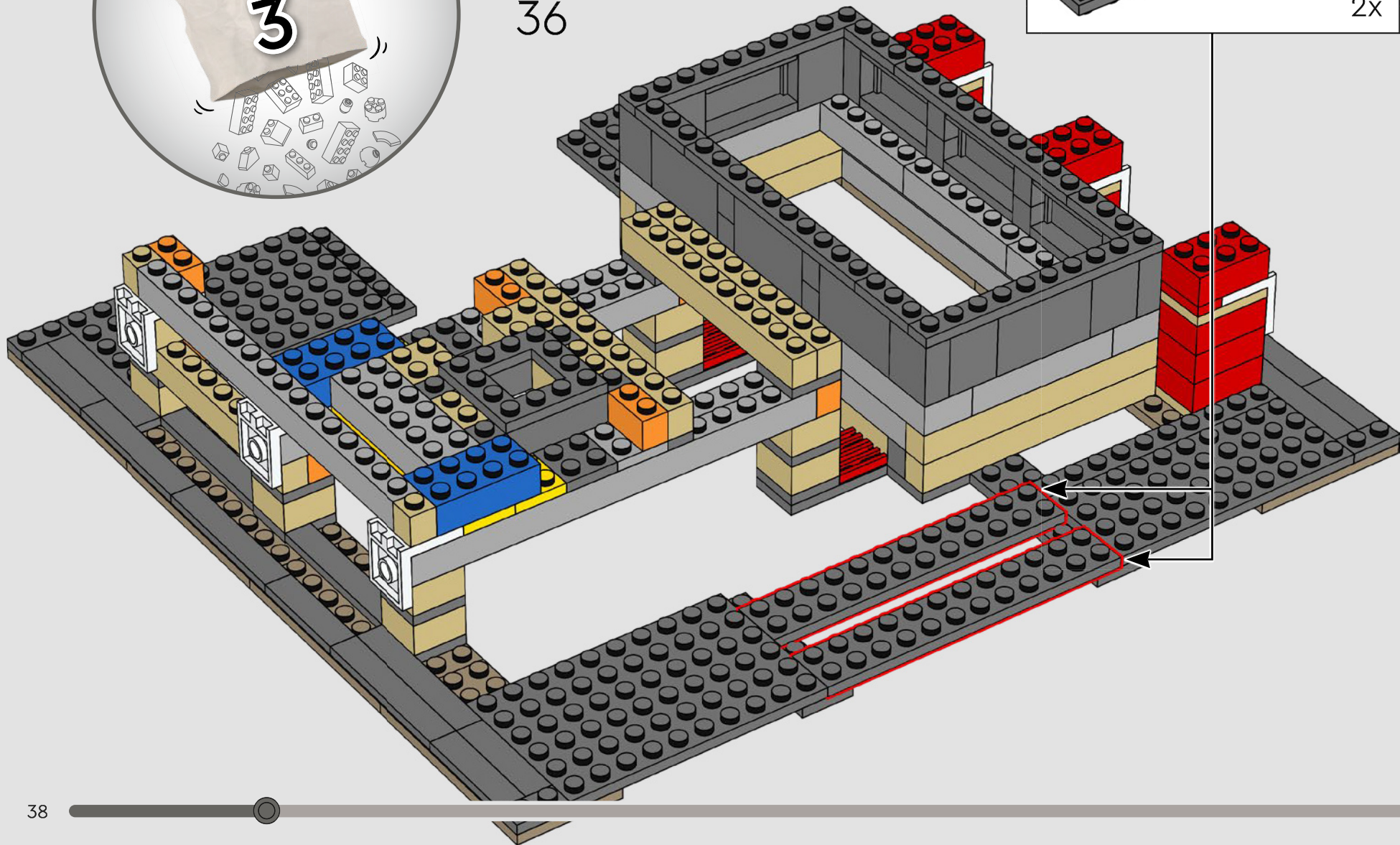
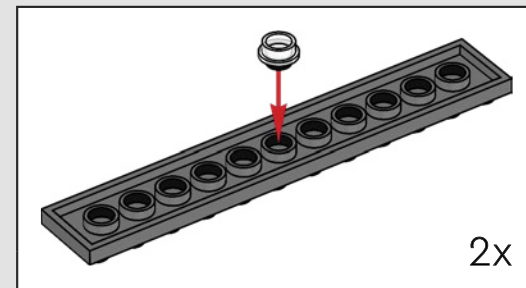

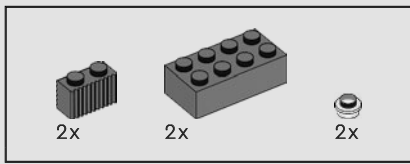

37

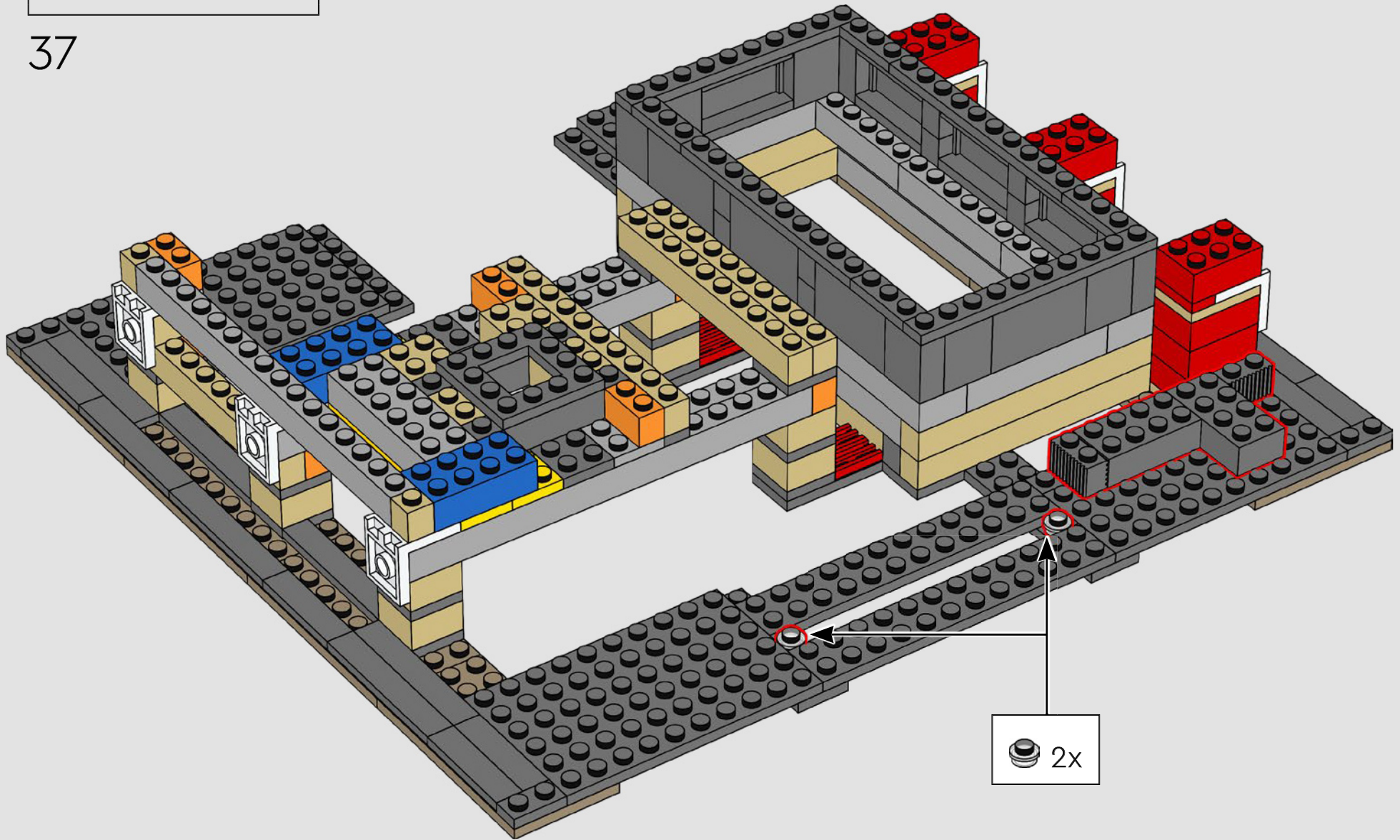

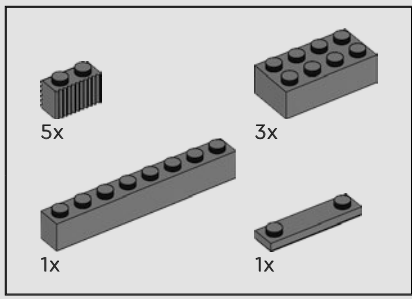

38

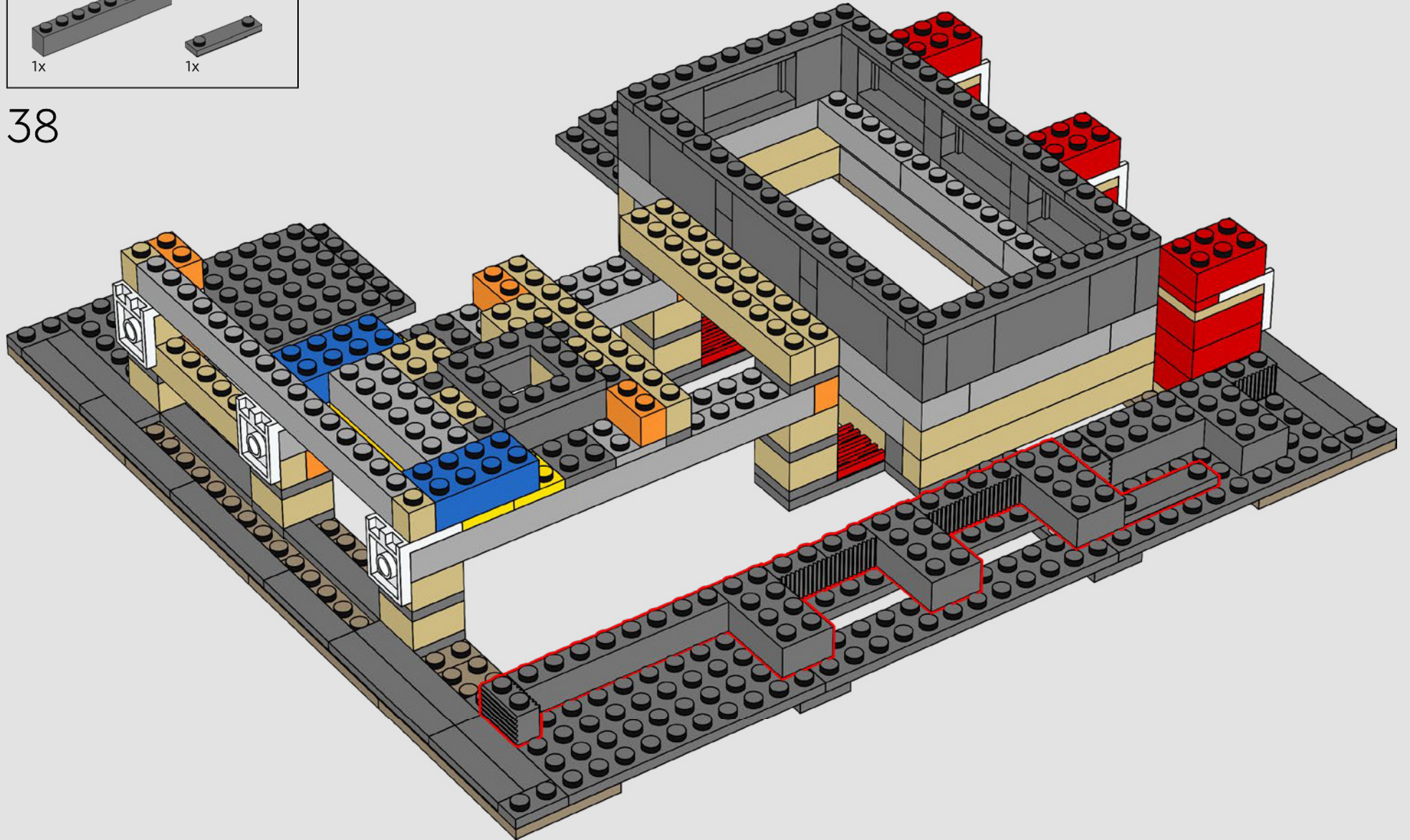

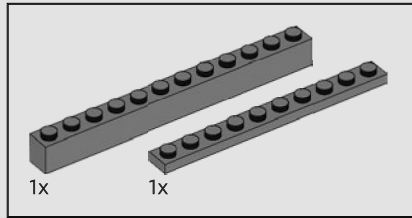
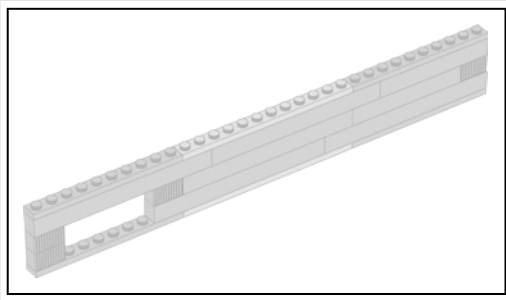

39

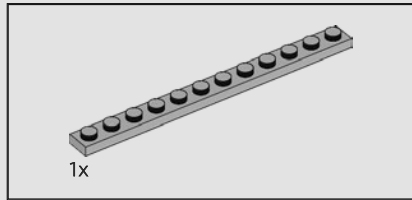
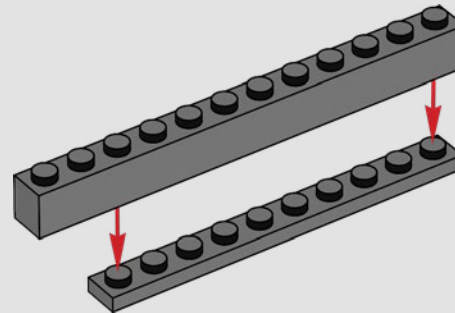

40

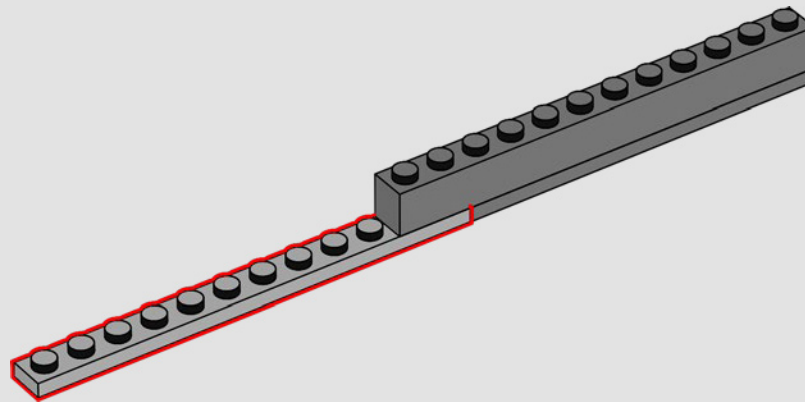

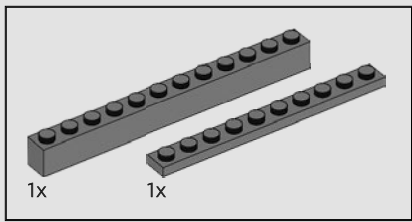

41

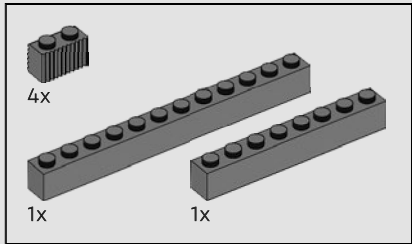
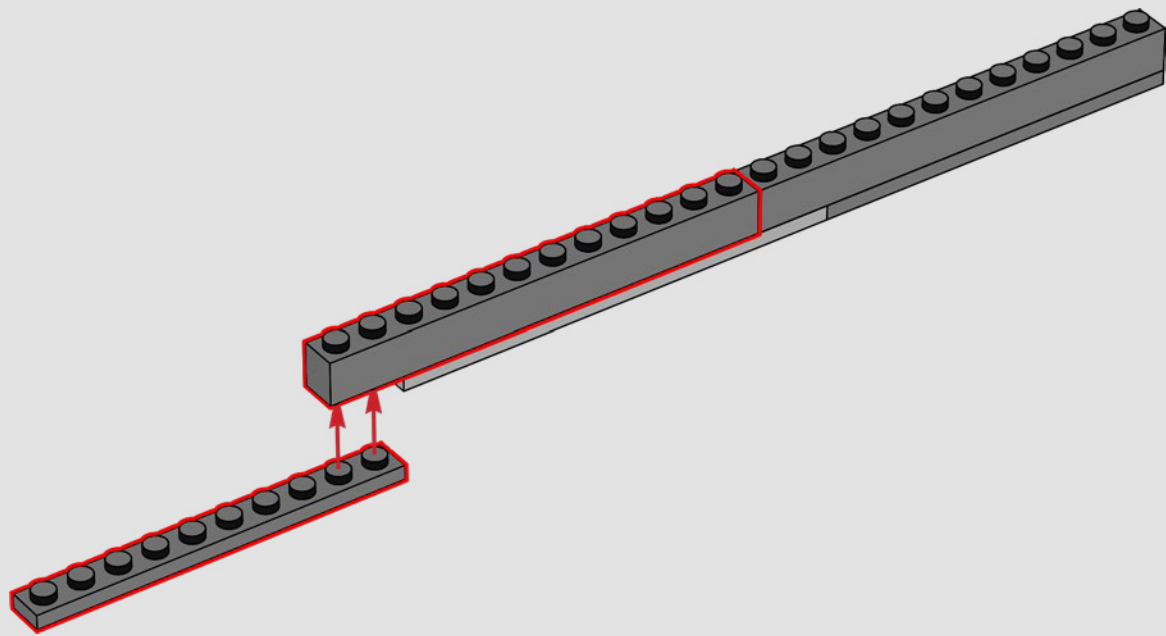

42

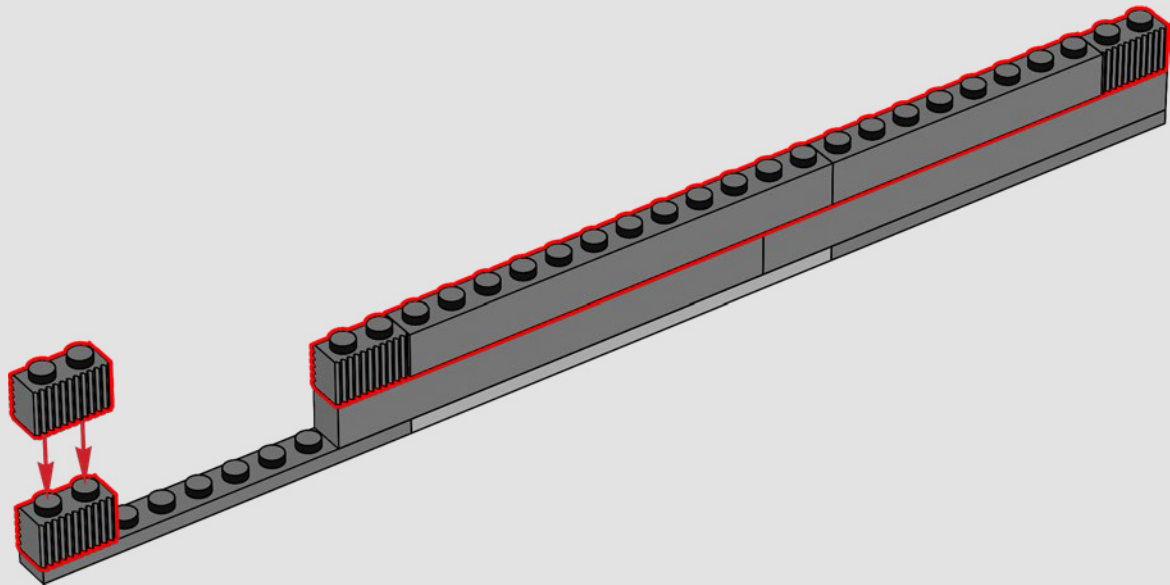

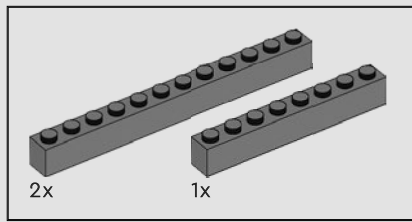

43

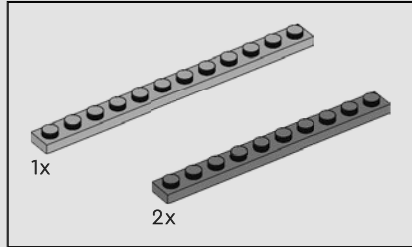
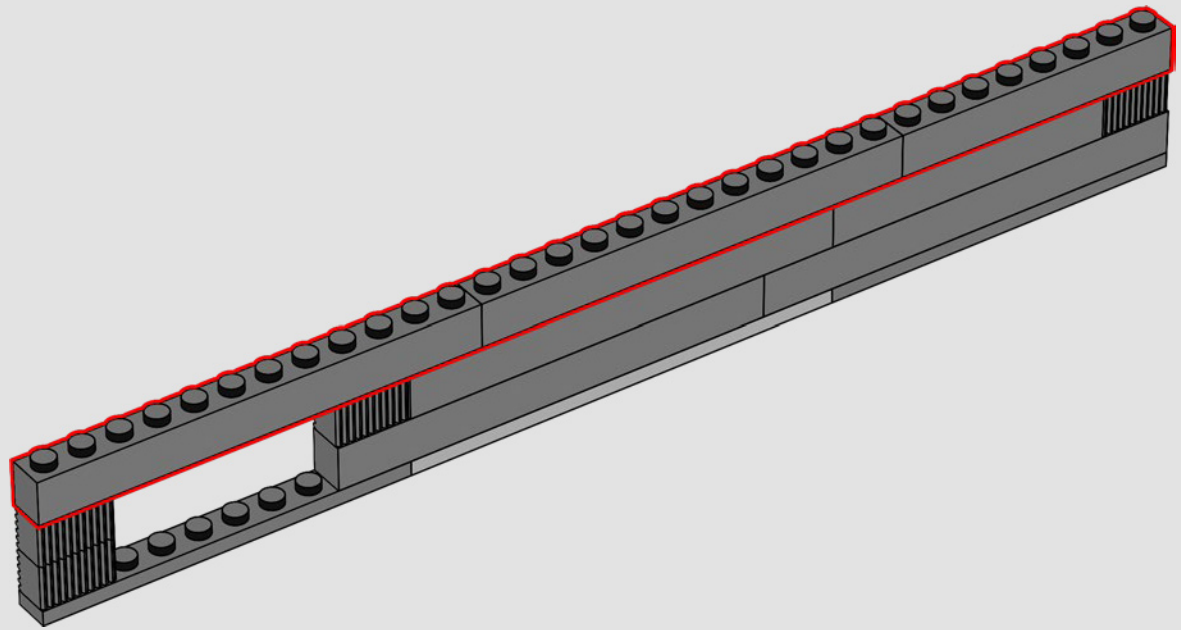

44

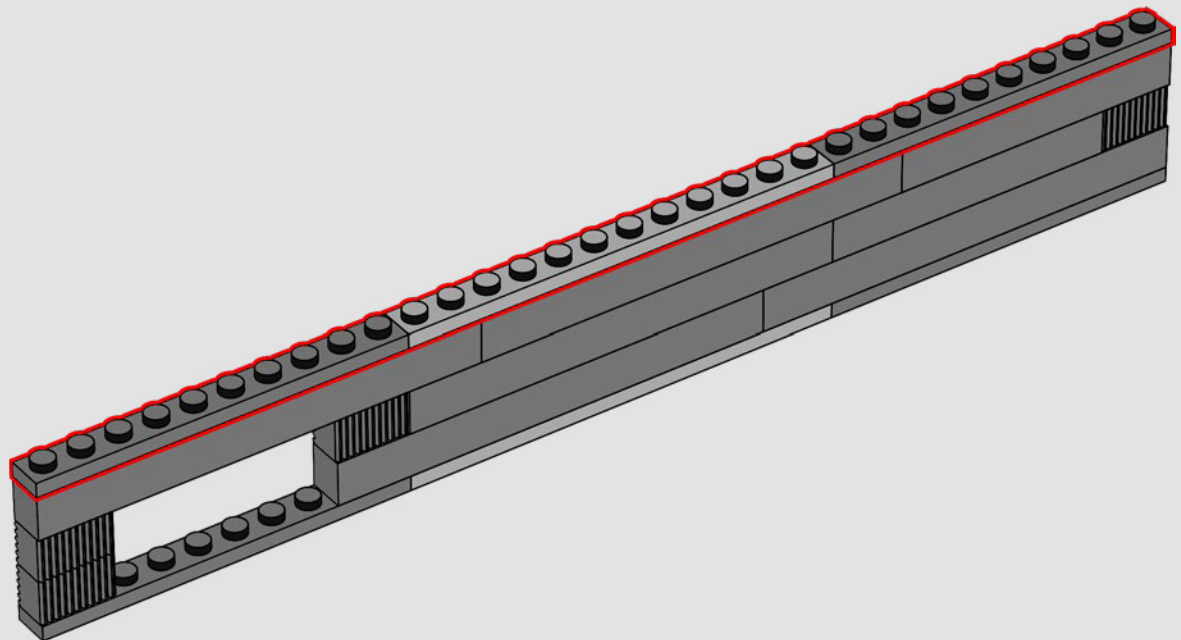

45

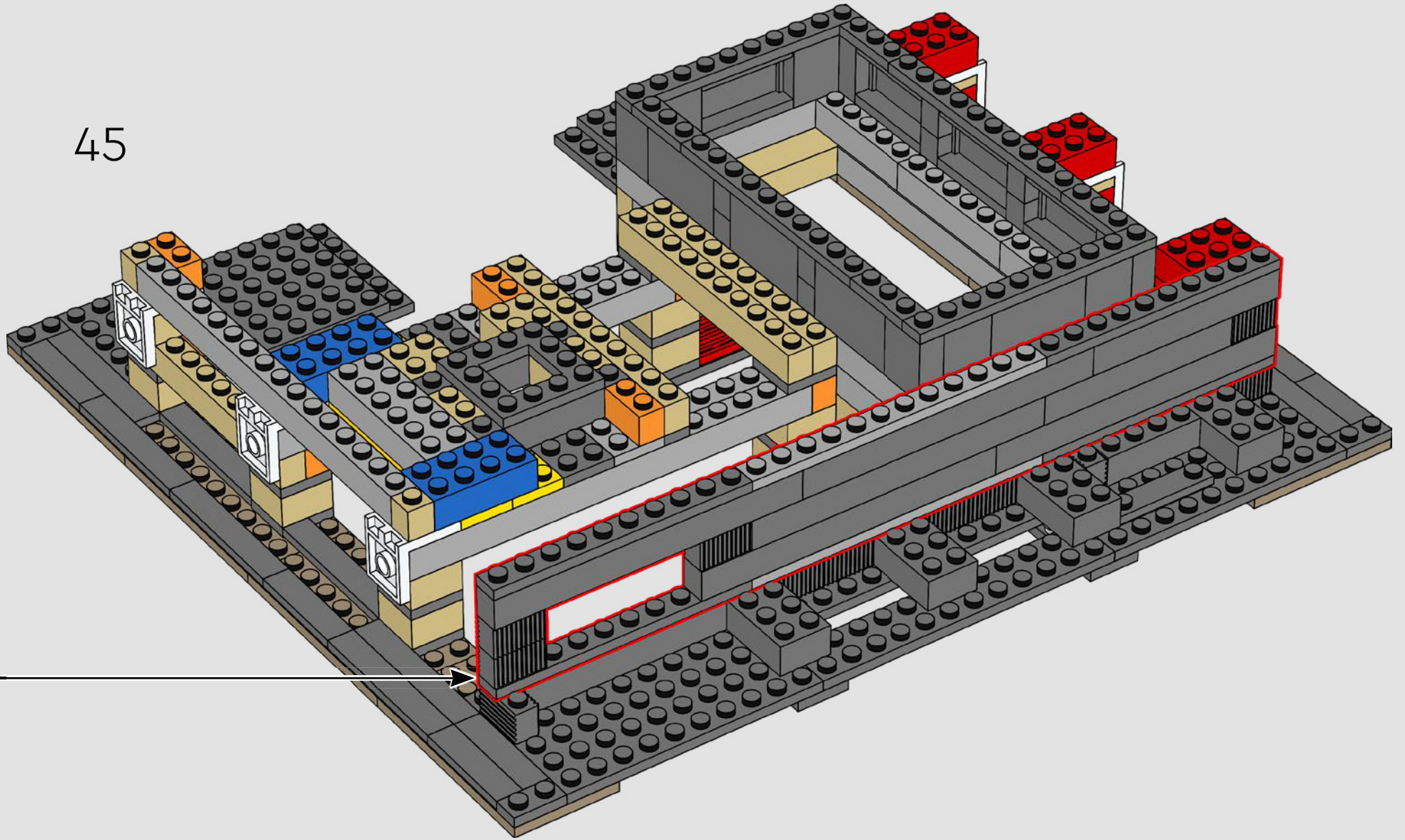

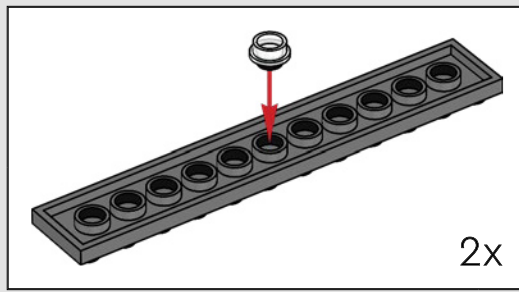
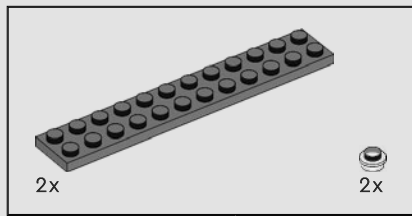

46

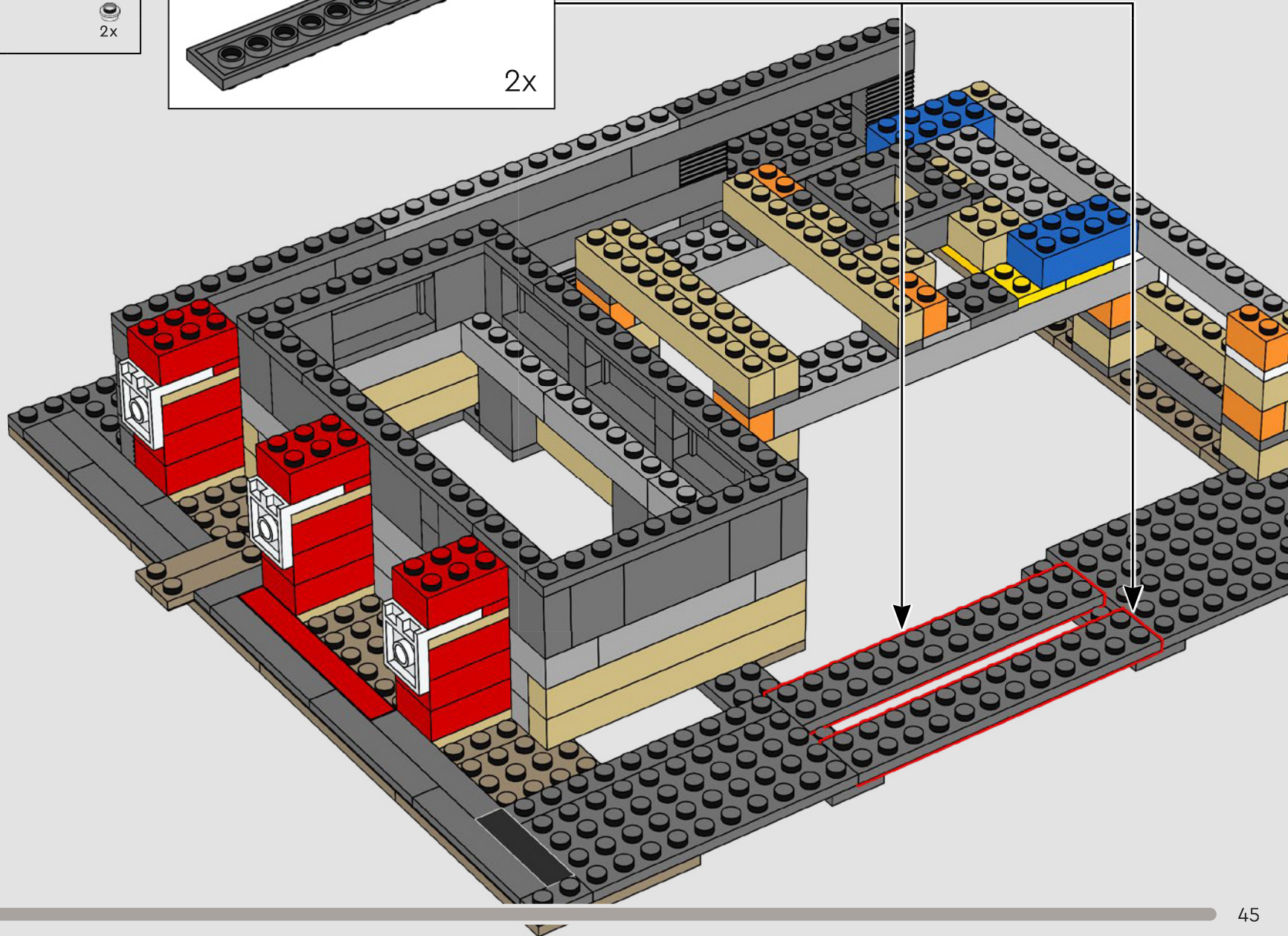

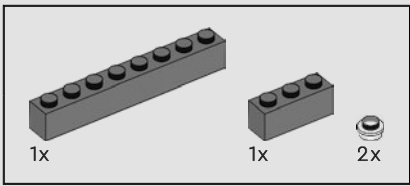

47

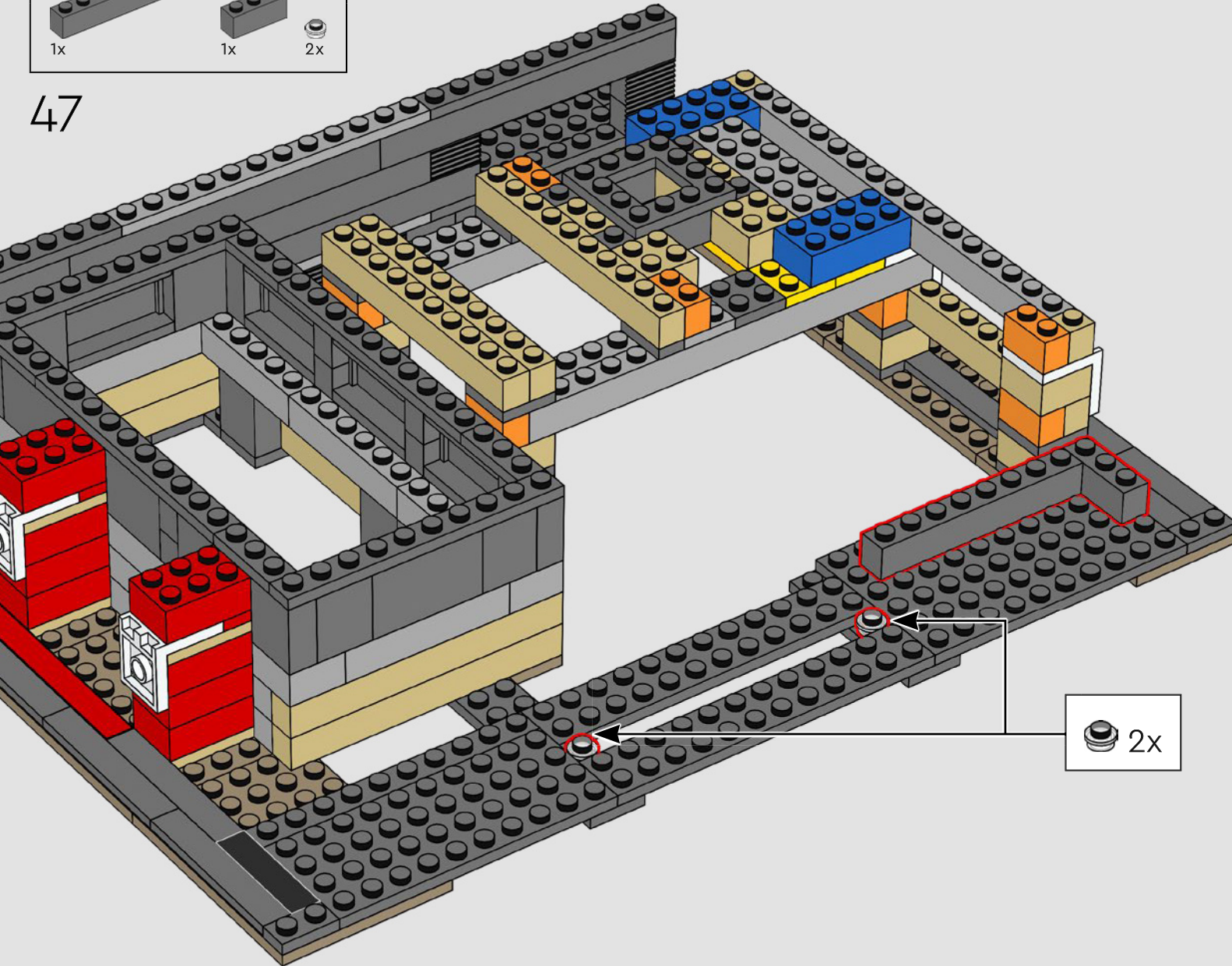

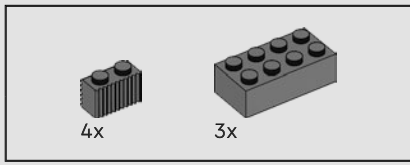

48

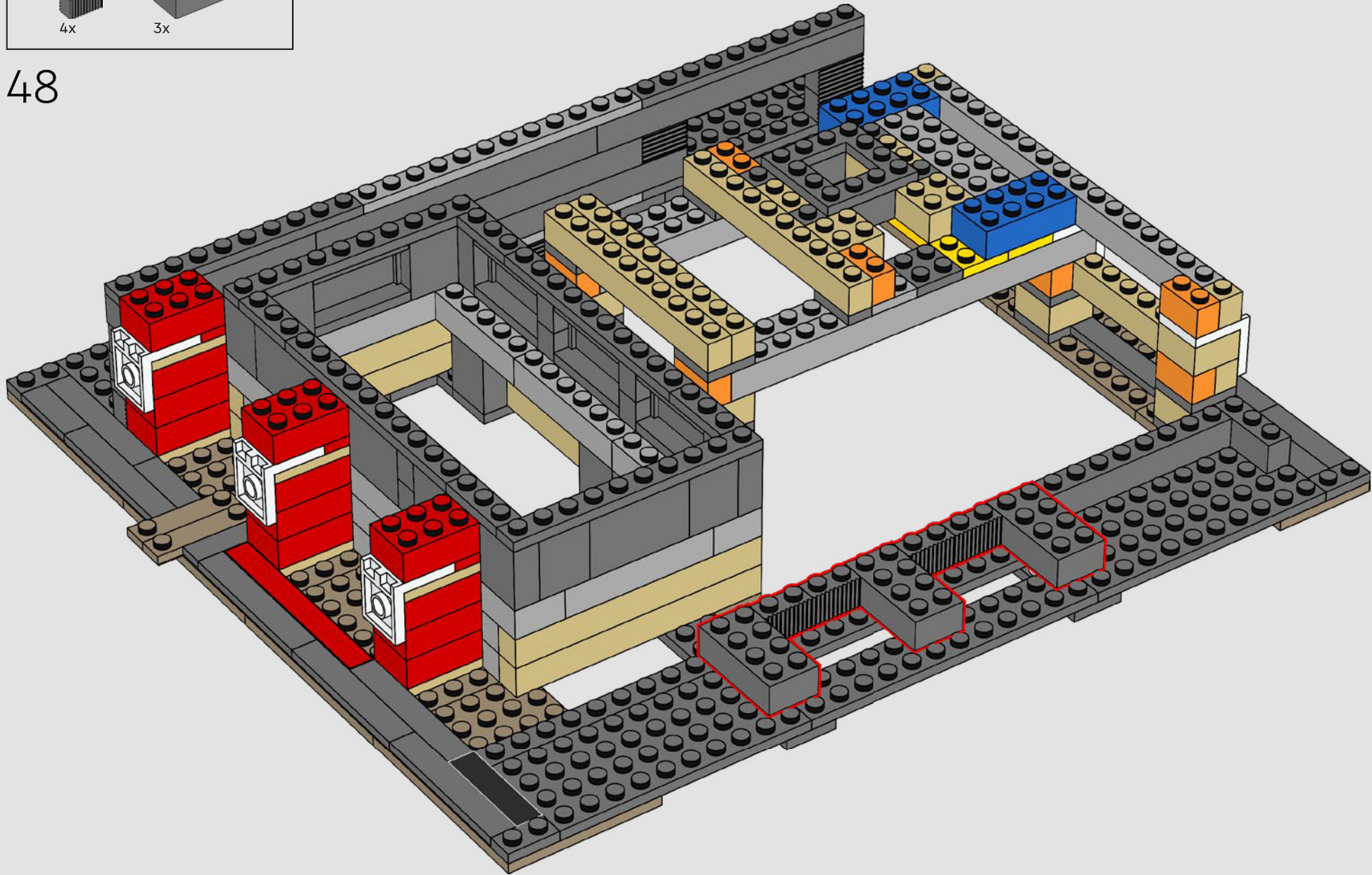

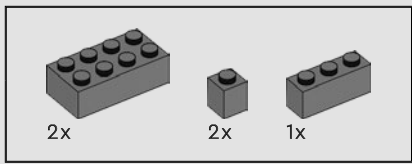

49

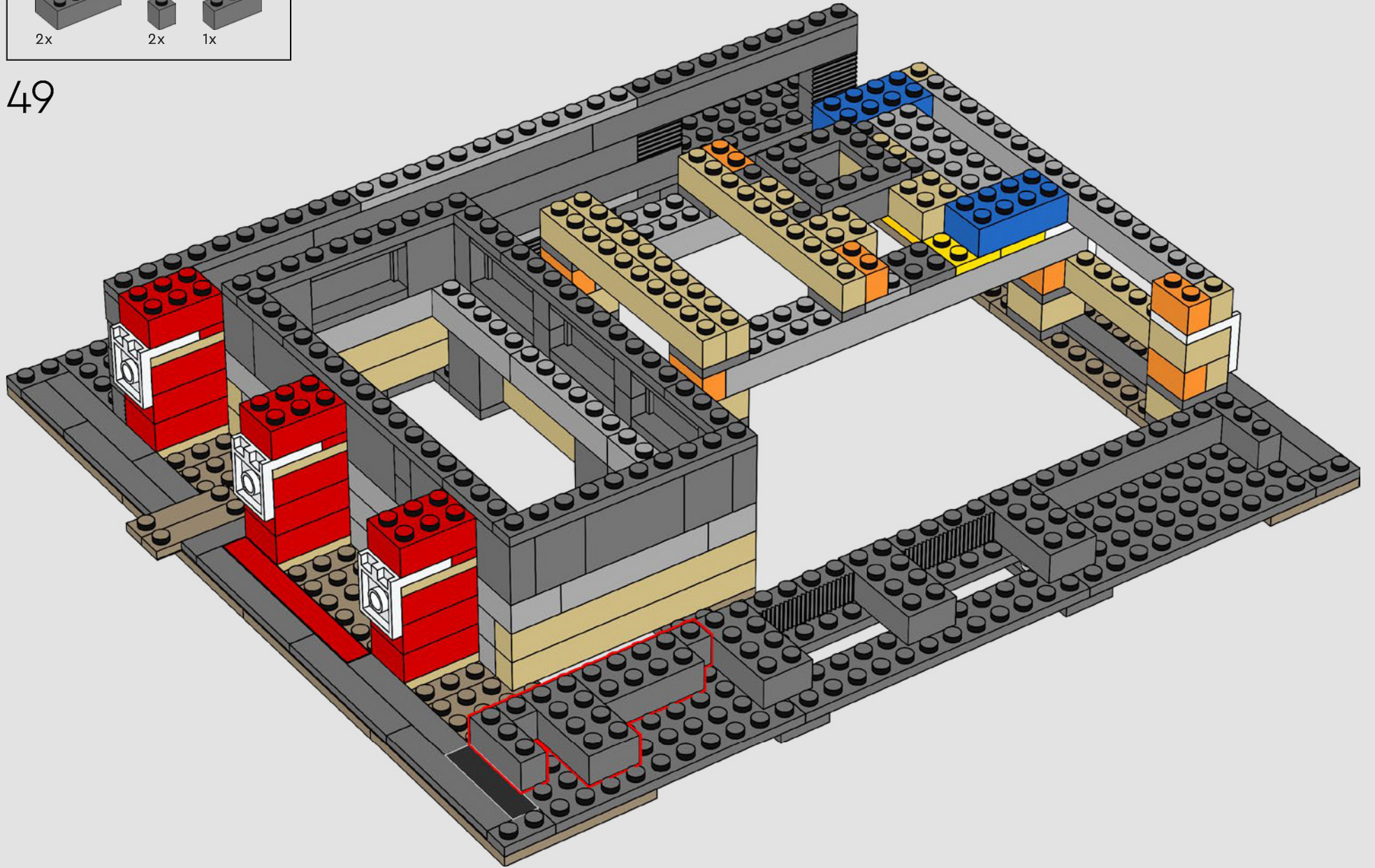

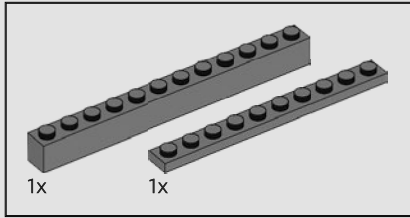
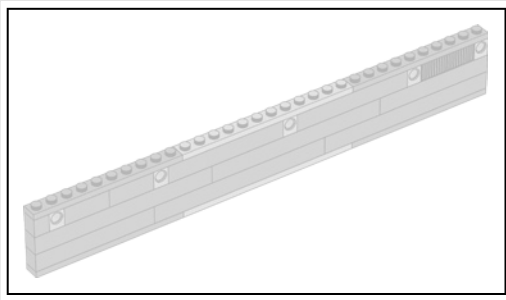

50

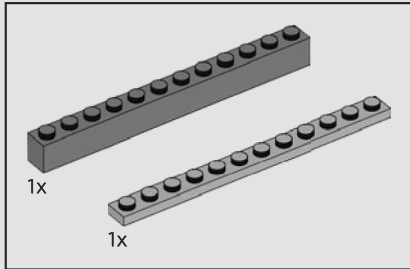
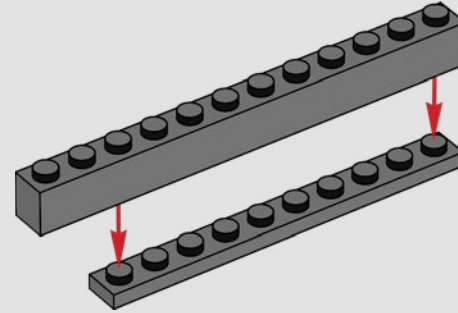

51

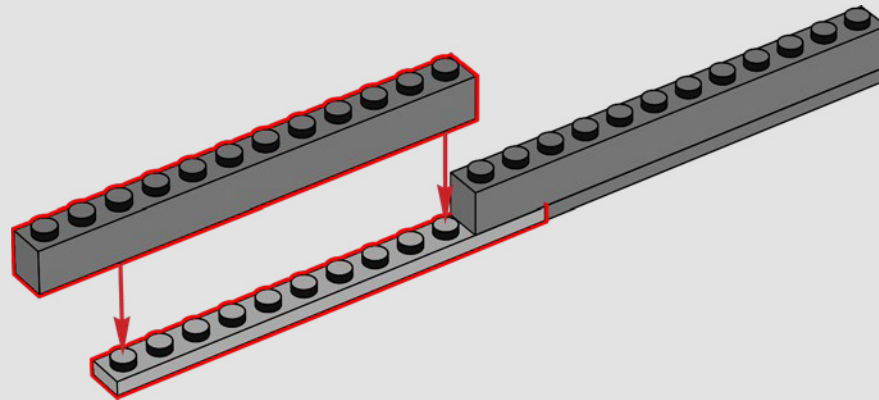

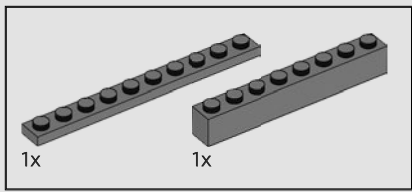

52

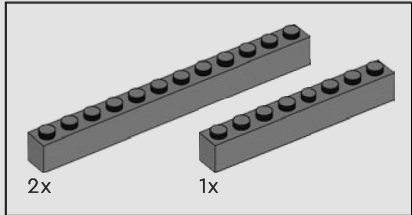
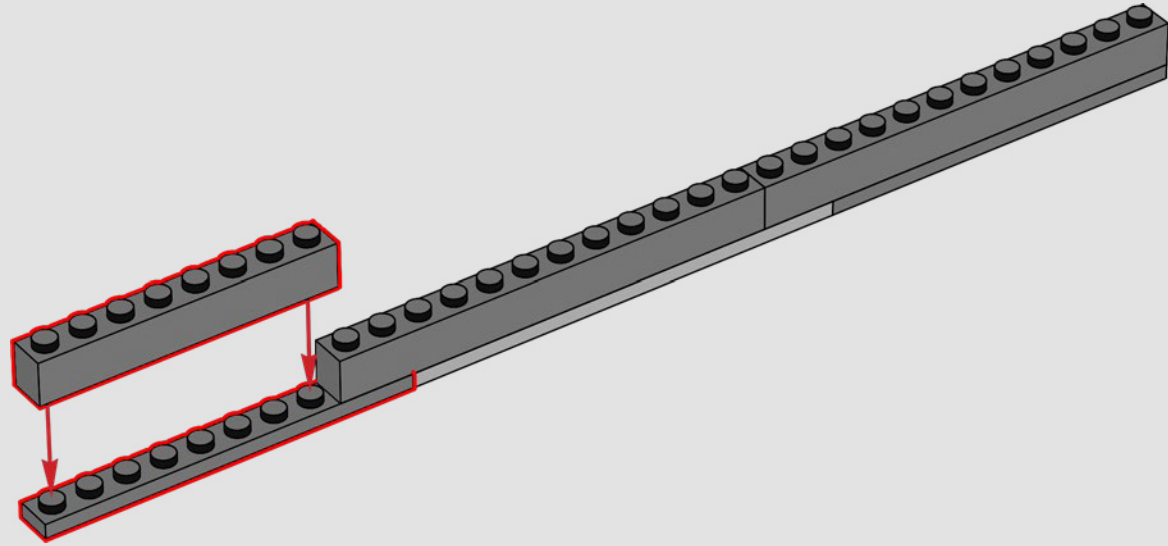

53

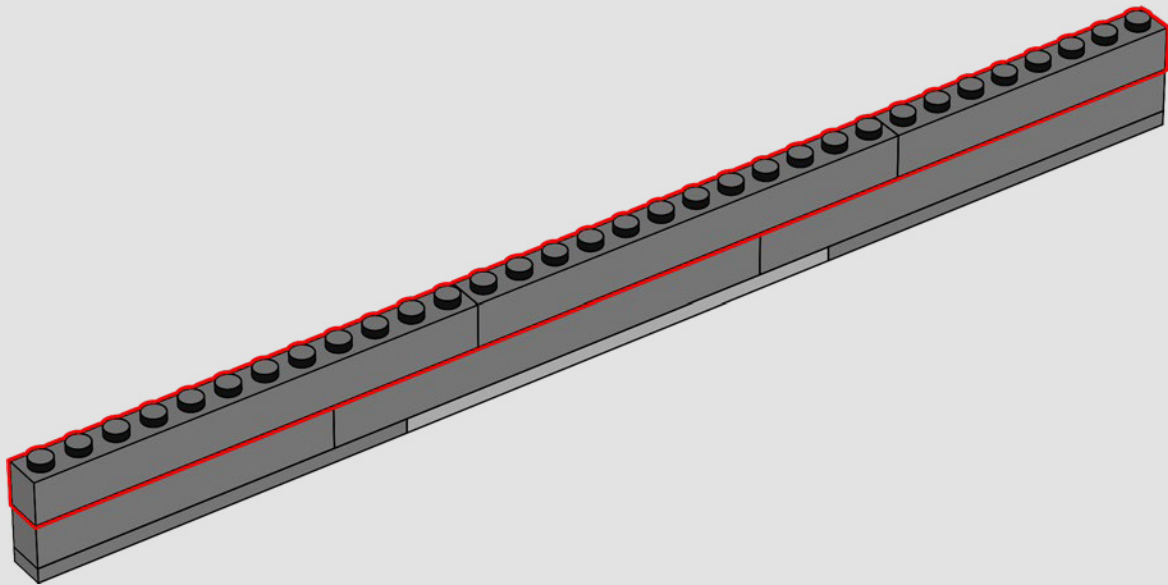

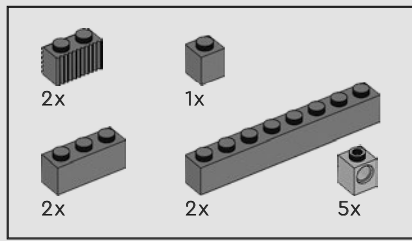

54

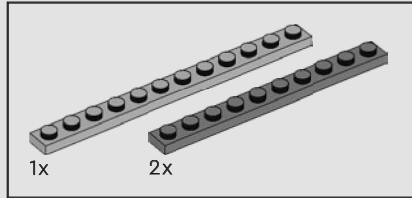
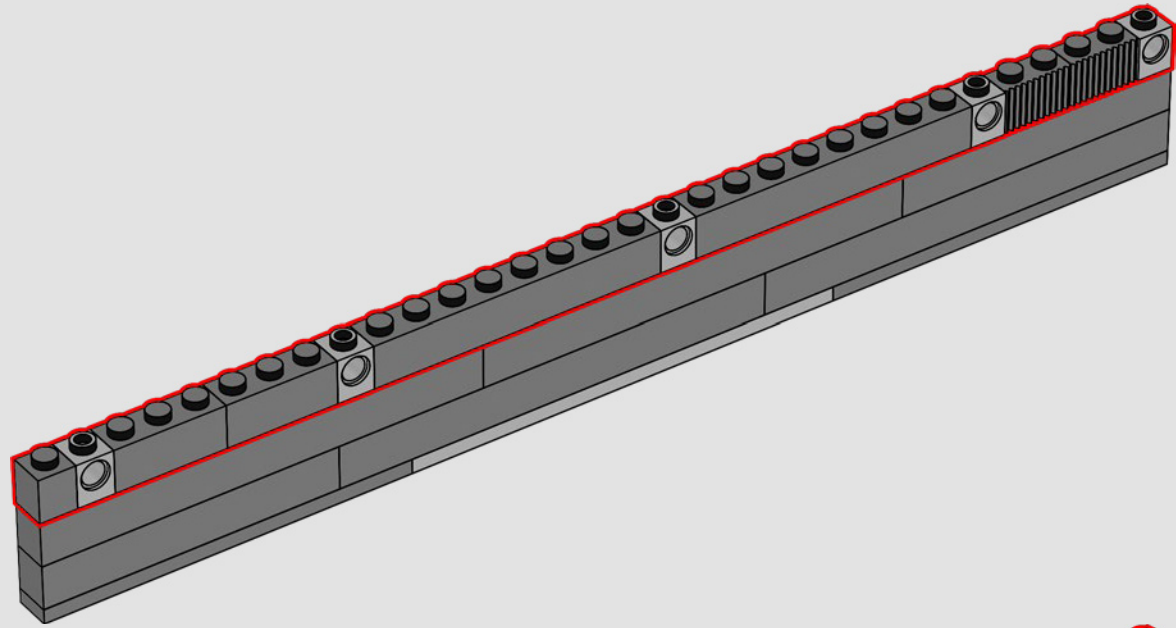

55

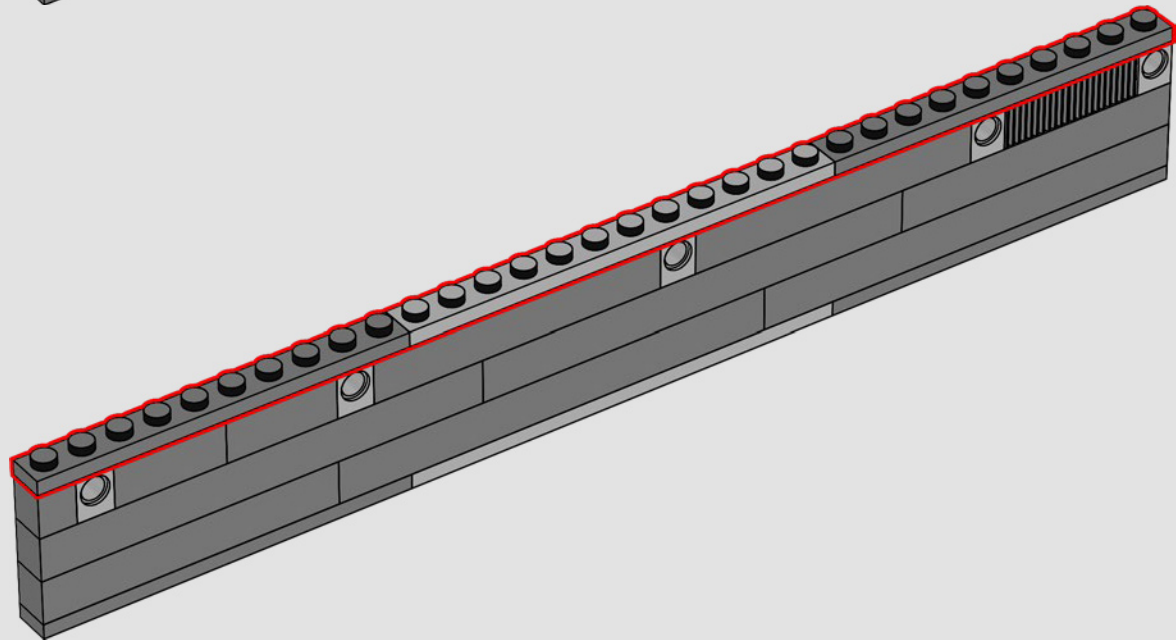

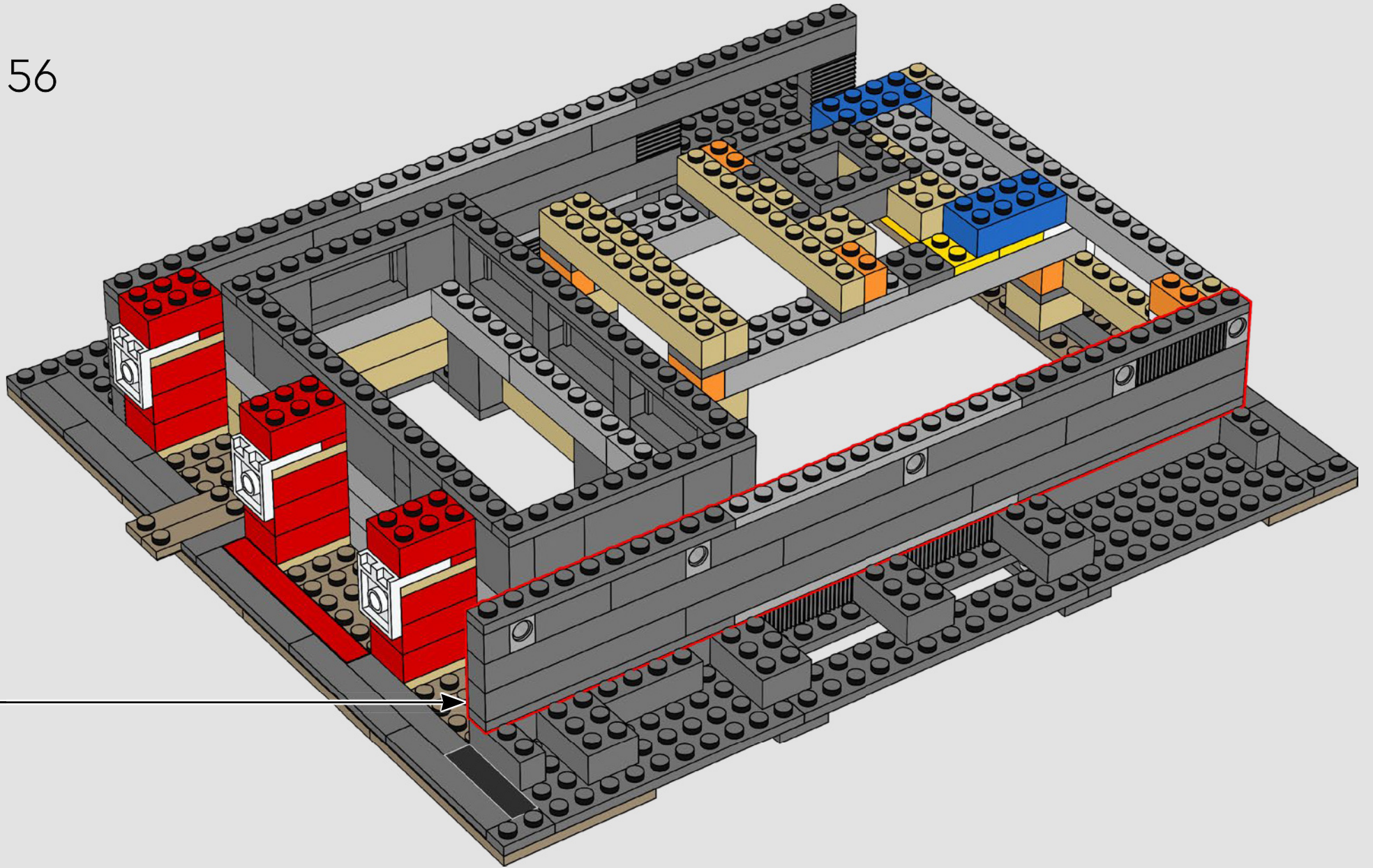

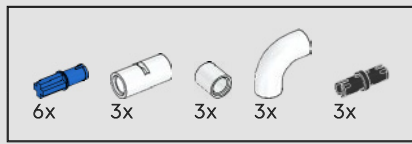

57

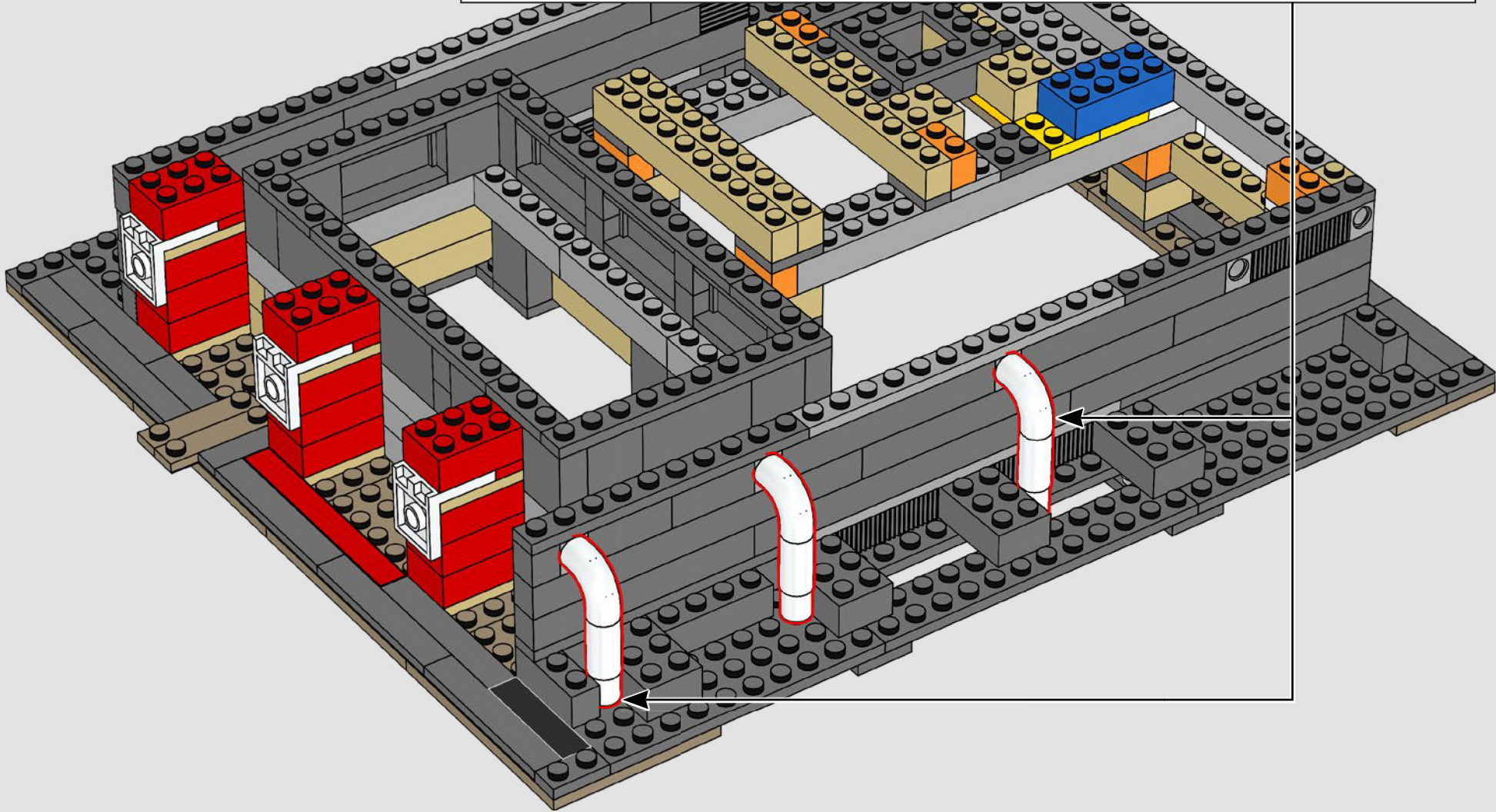
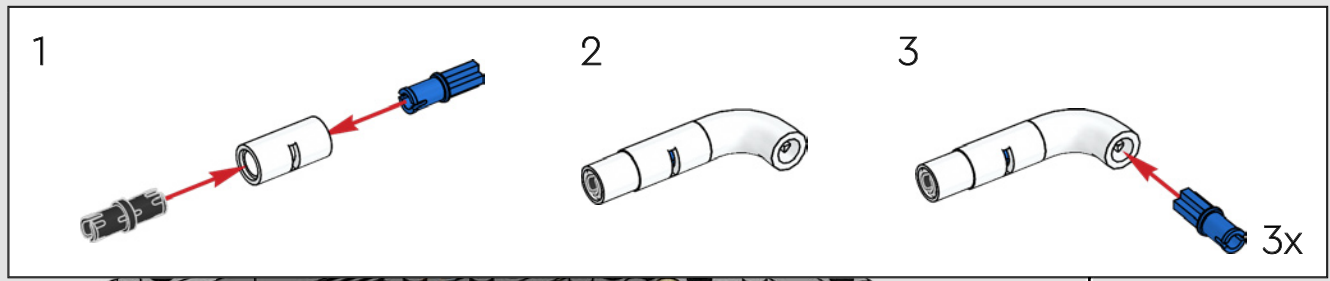

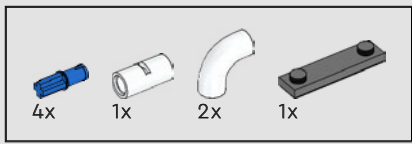

58

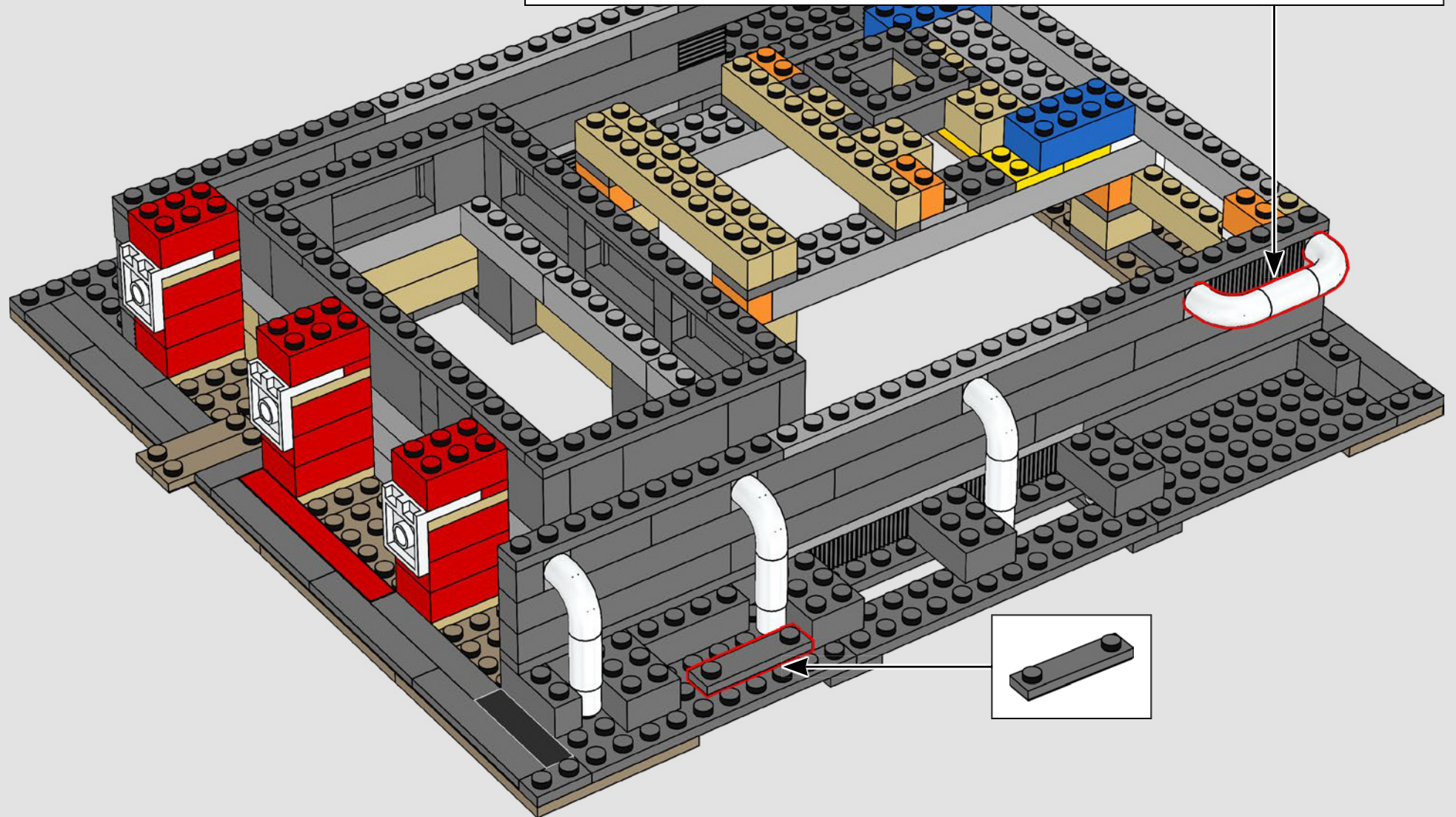
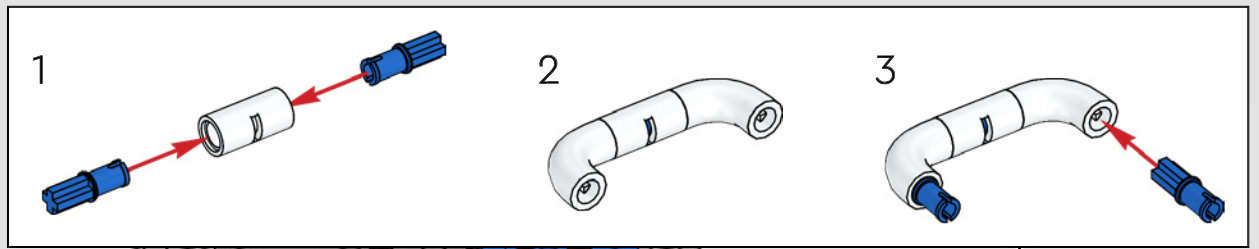

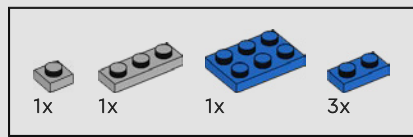

59

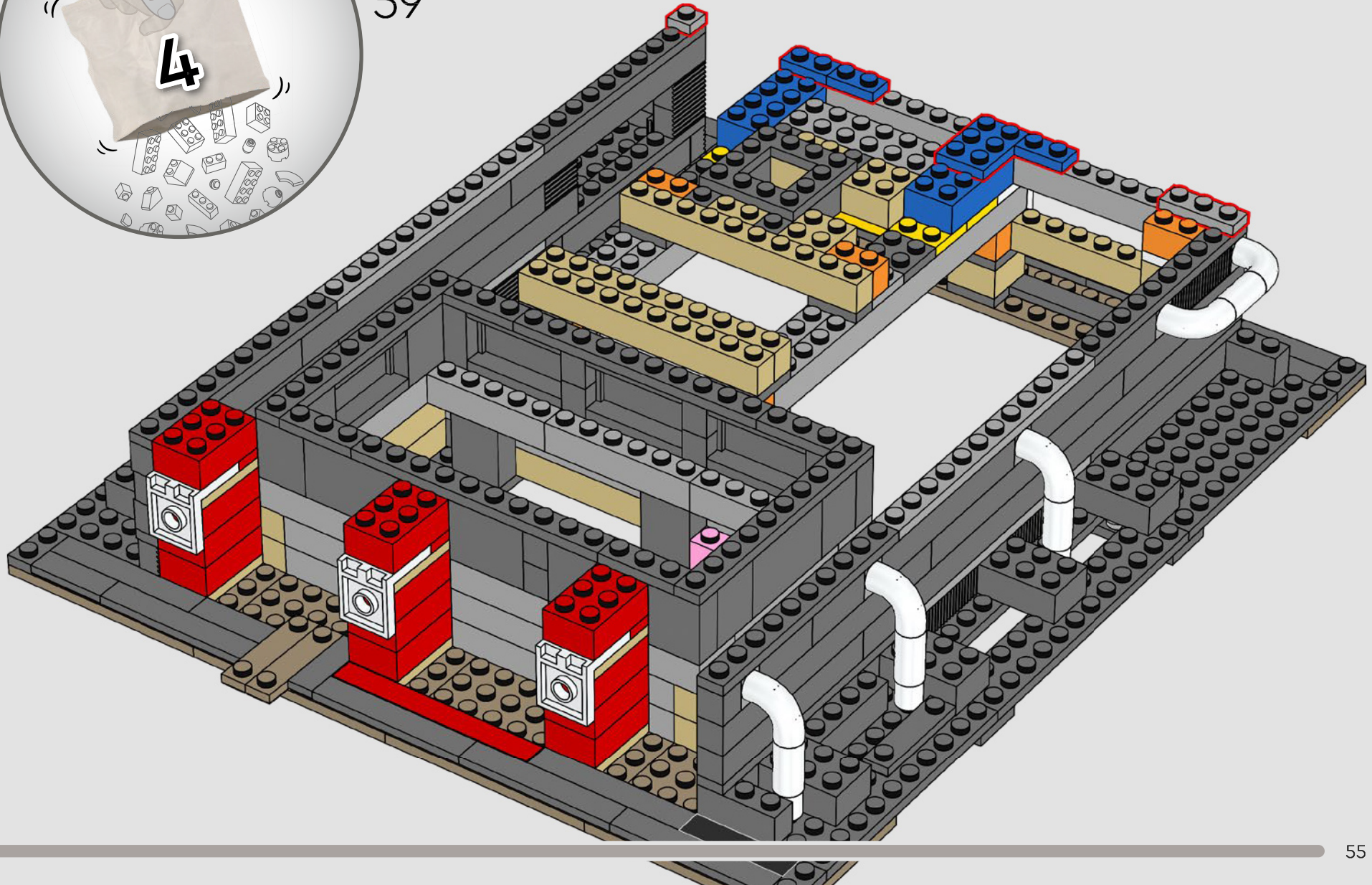

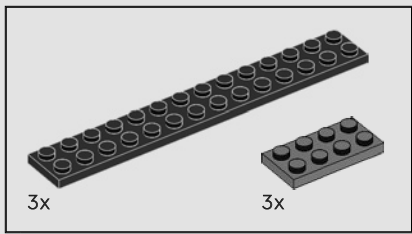

60

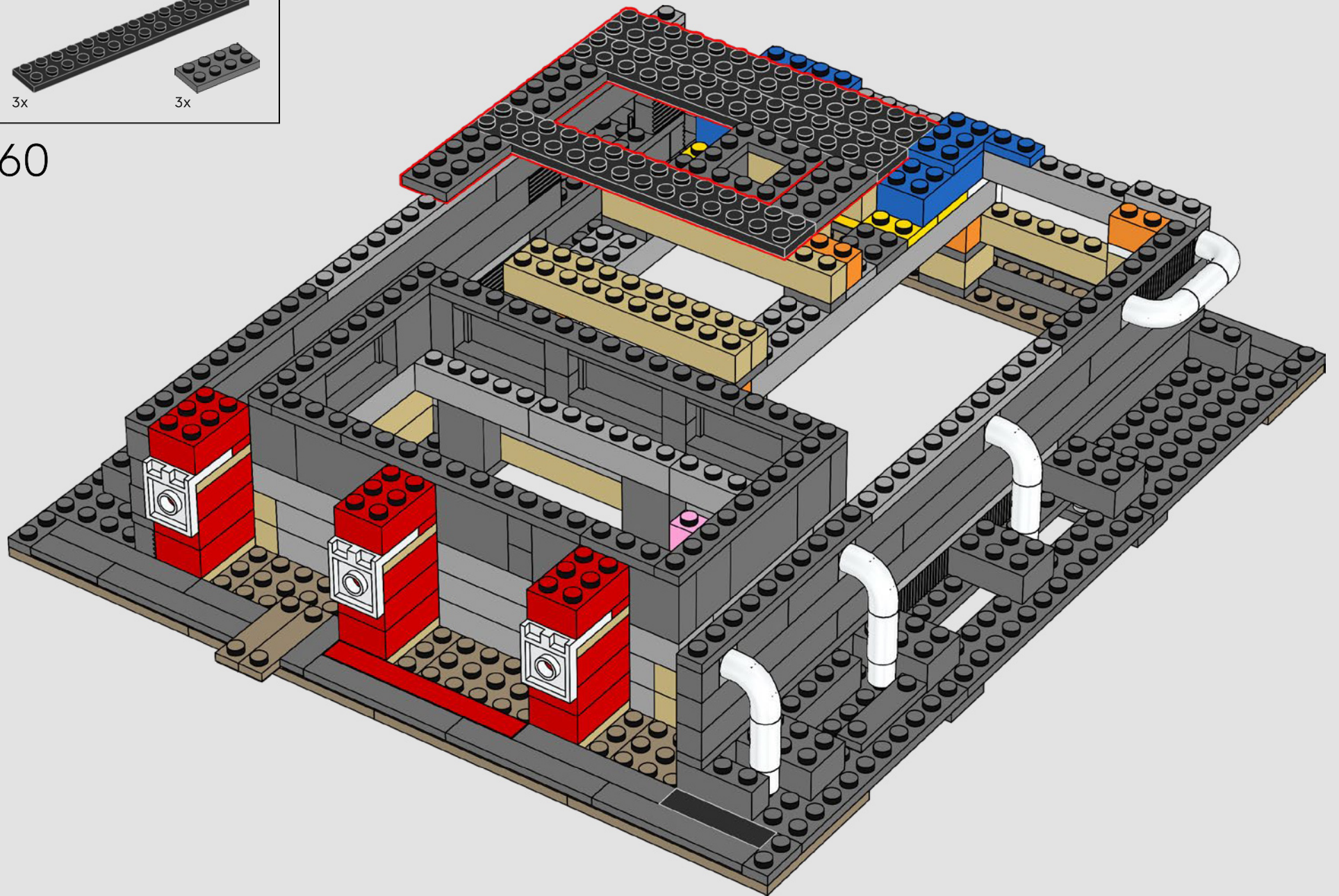

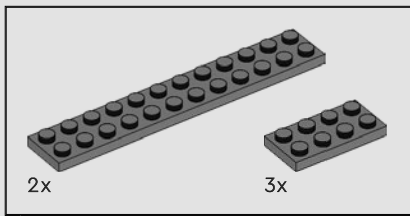

61

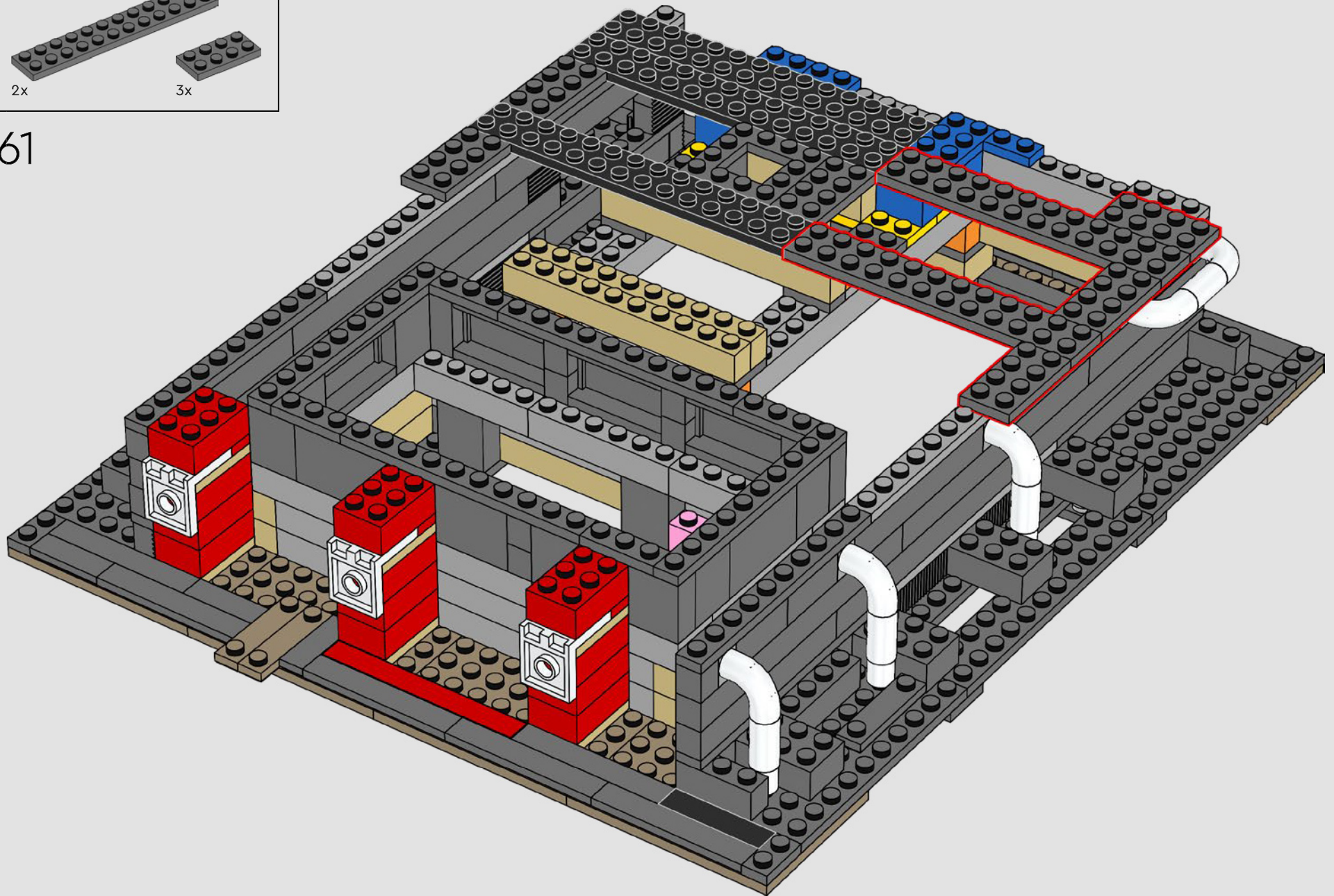

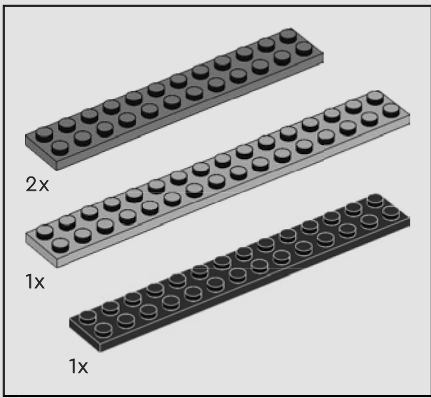

62

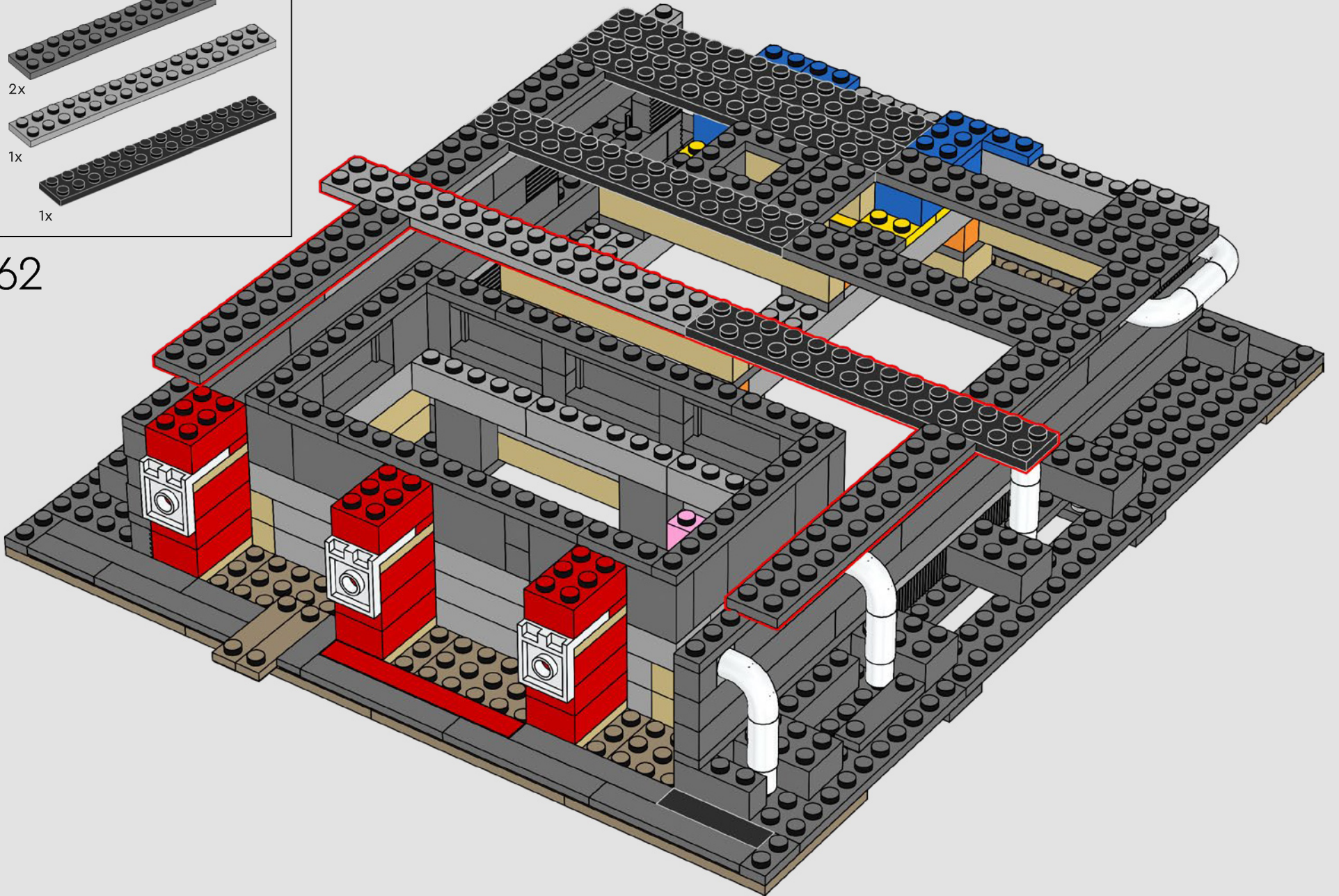

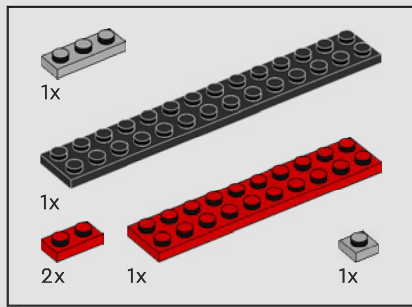

63

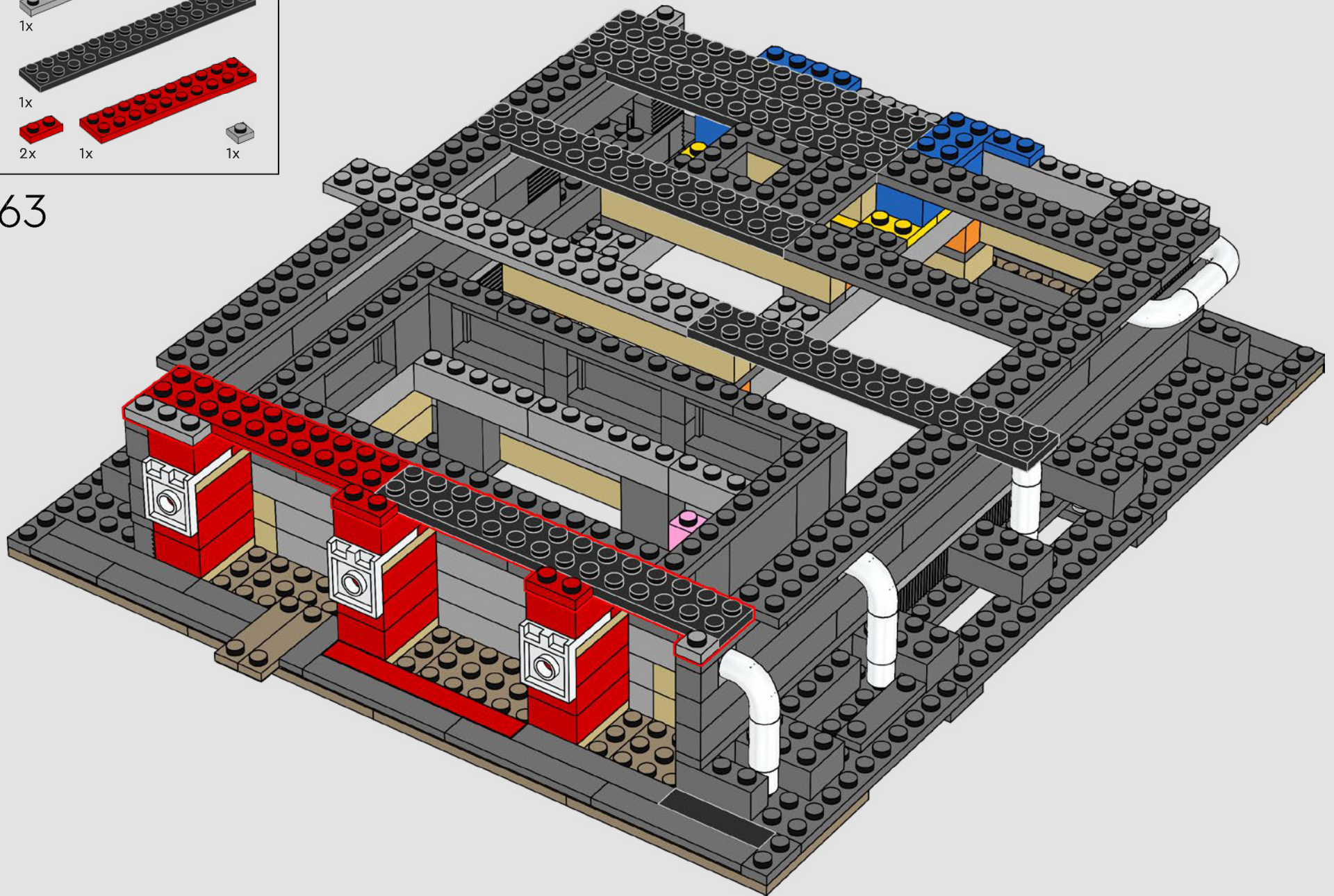

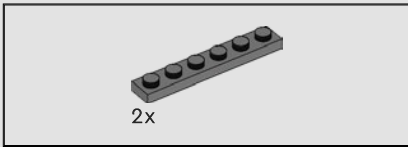
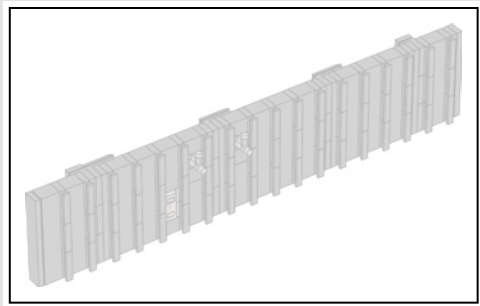

64

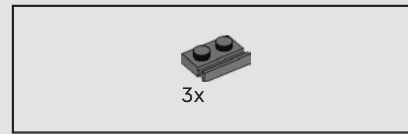
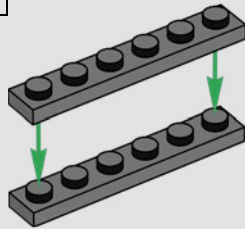

65

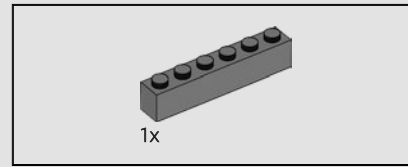
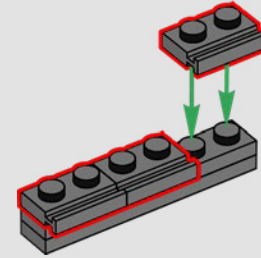

66

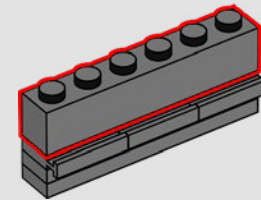

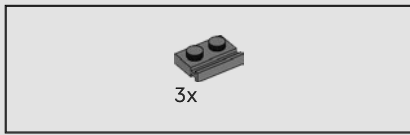

67

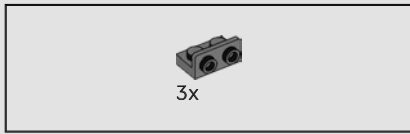
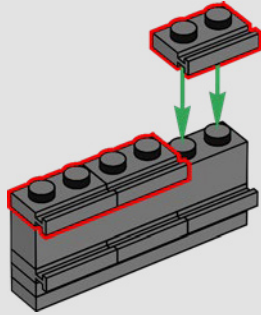

68

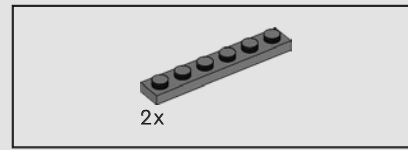
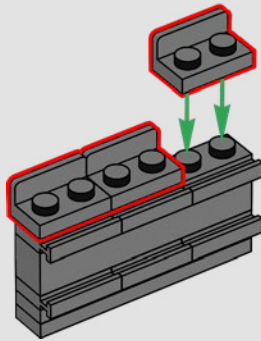

69

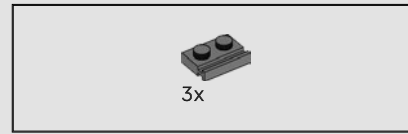
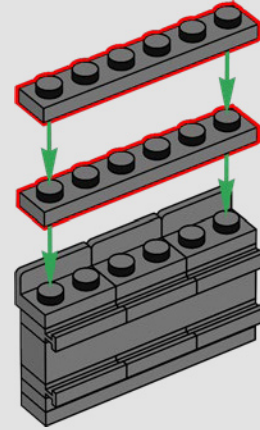

70

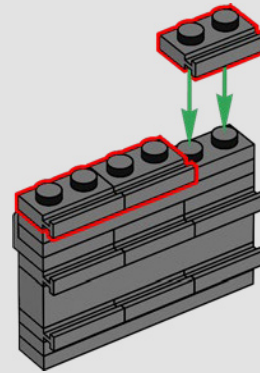

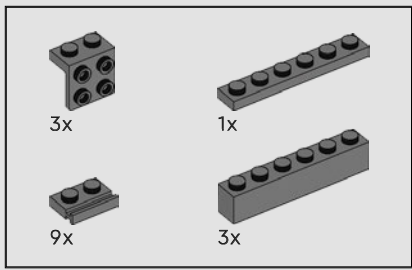

71

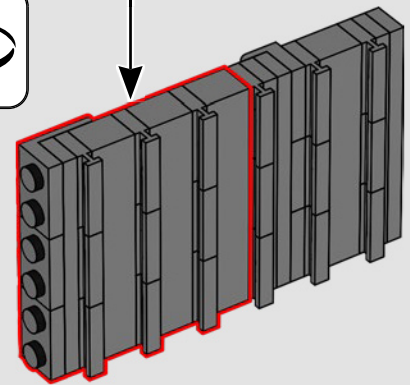
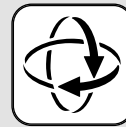
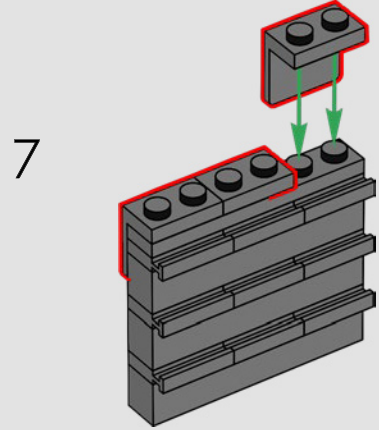
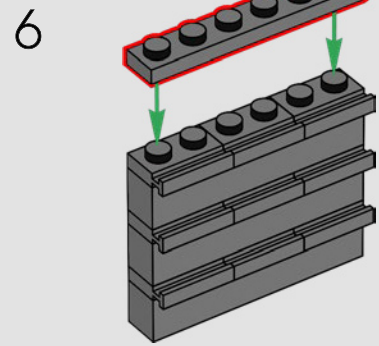
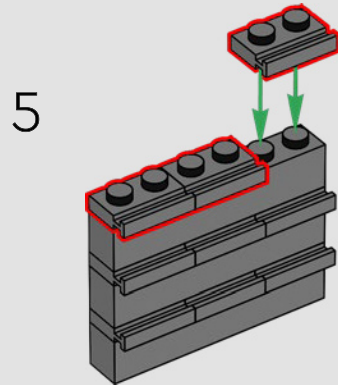
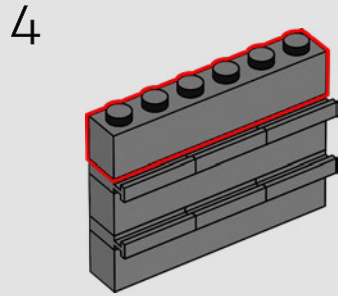
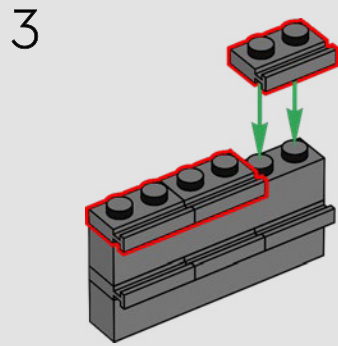
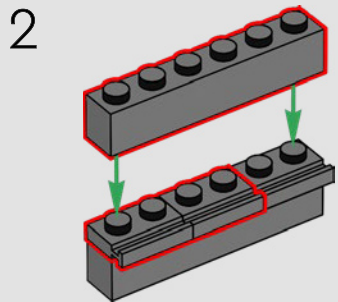
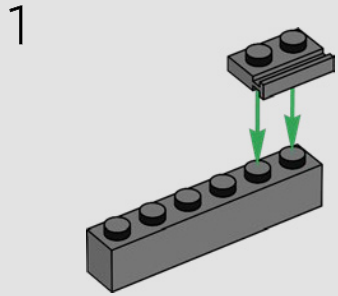

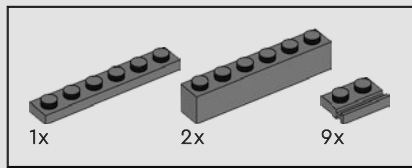

72

1

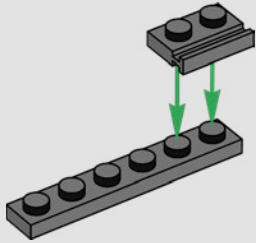

2

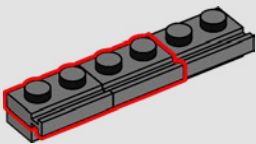

3

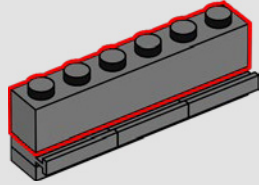

4

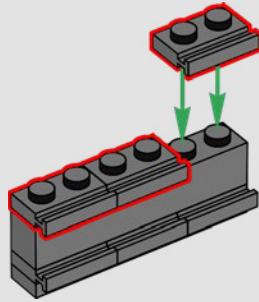

5

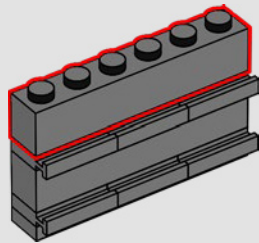

6

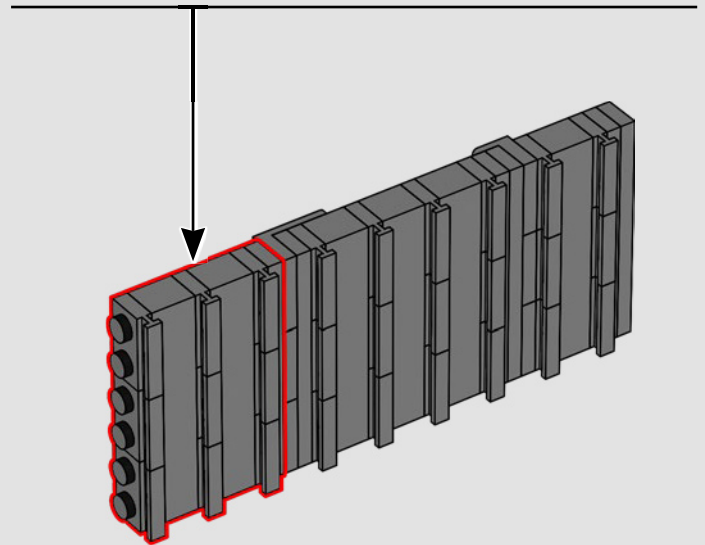
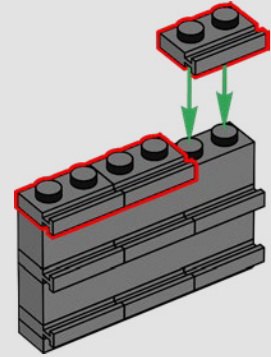

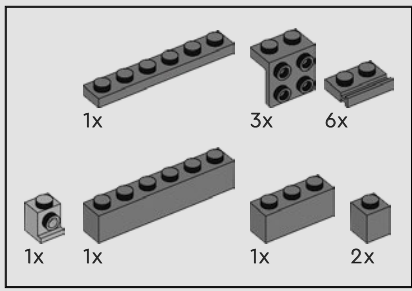

73

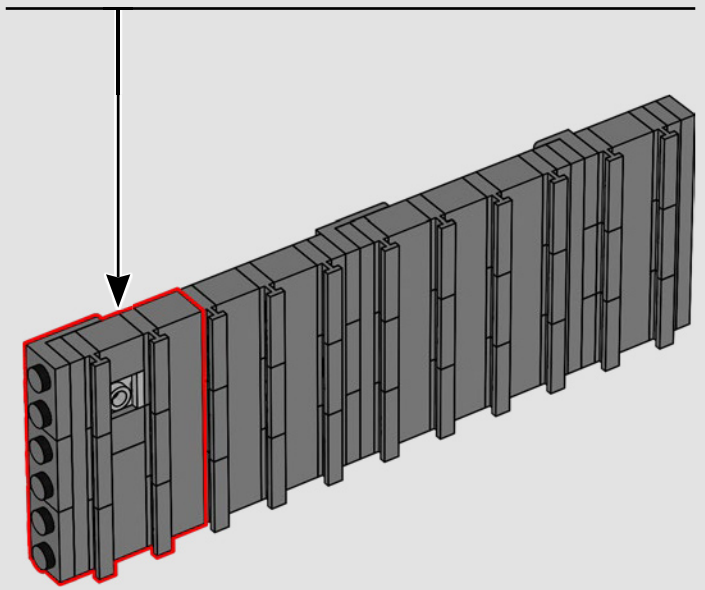
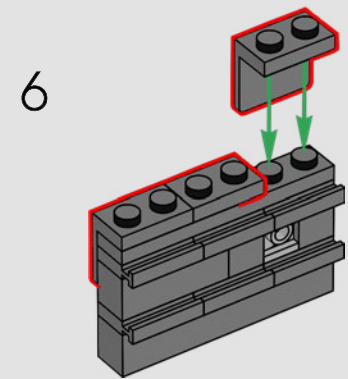
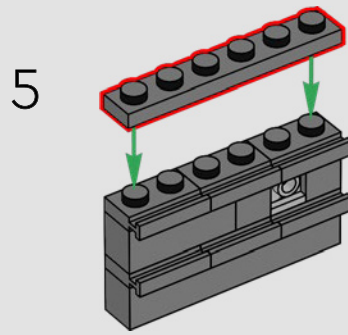
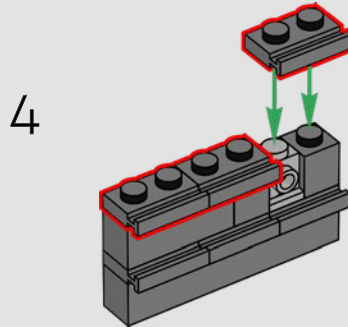
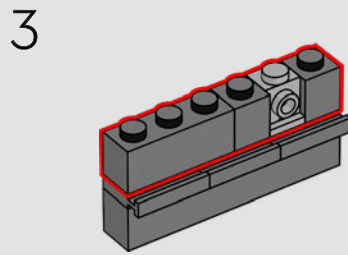
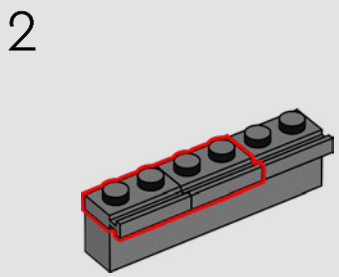
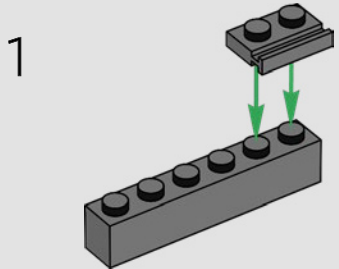

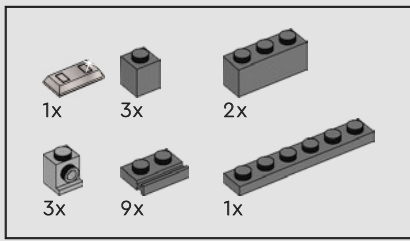

74

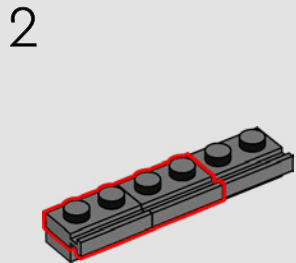
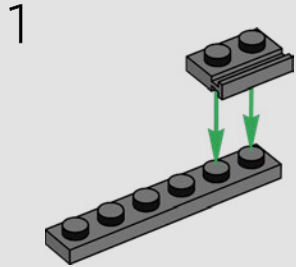

3

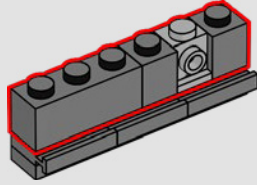

4

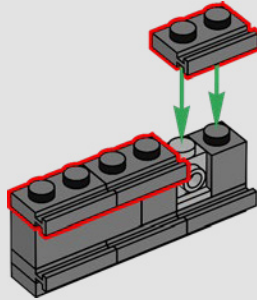

5

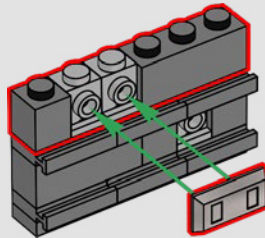

6

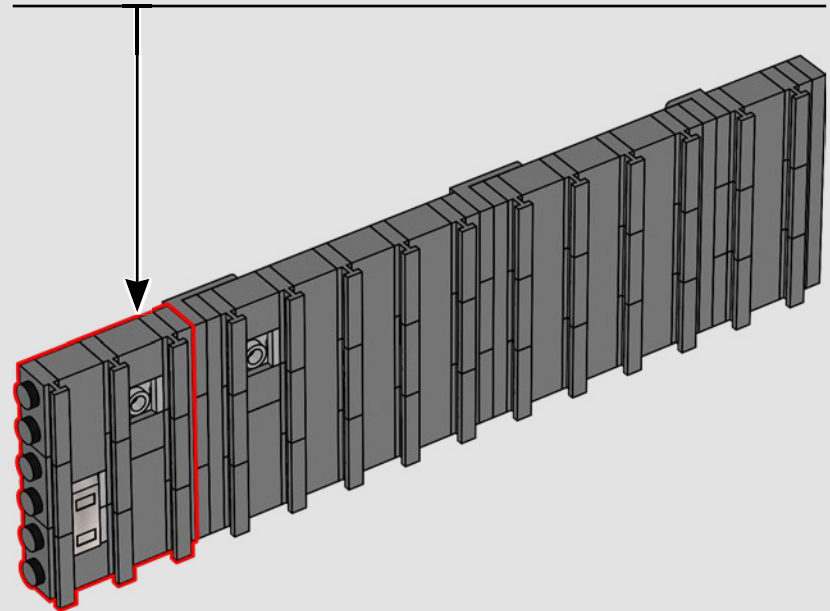
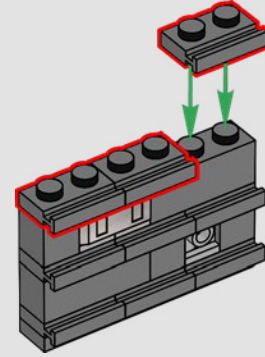

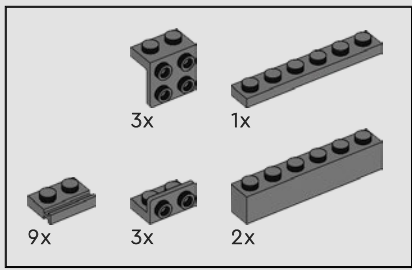

75

1

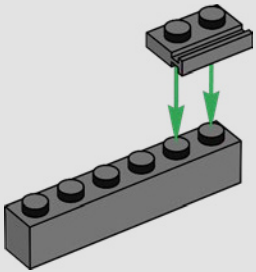

2

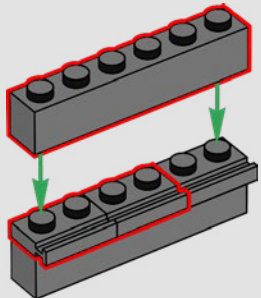

3

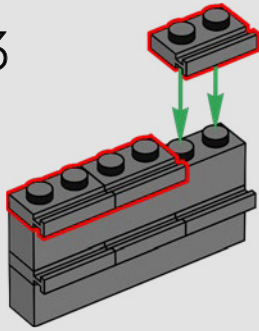

4

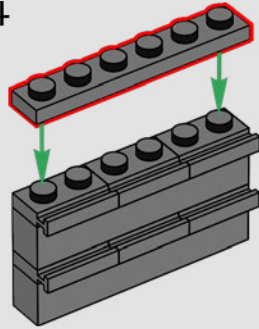

5

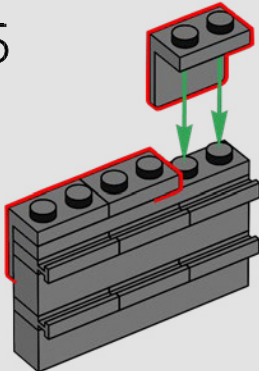

6

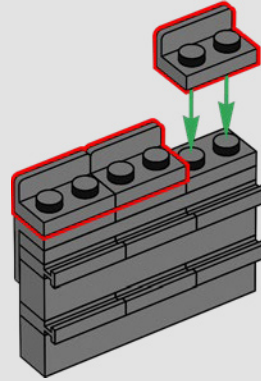

7

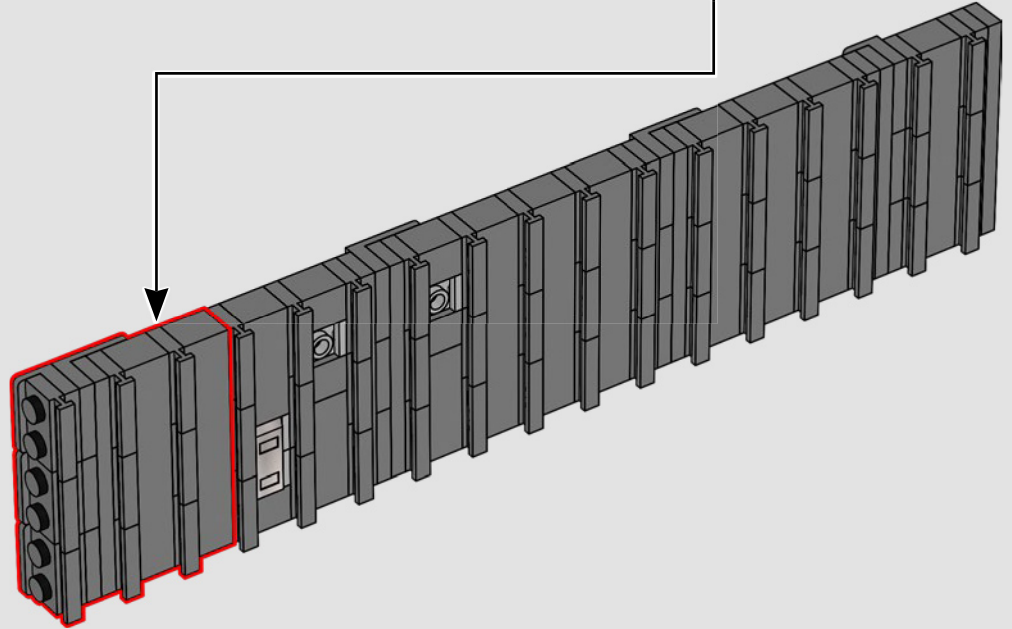
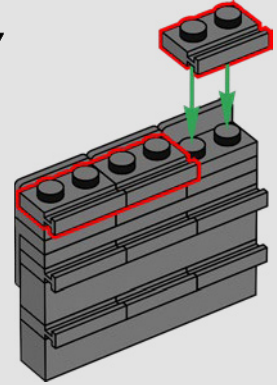

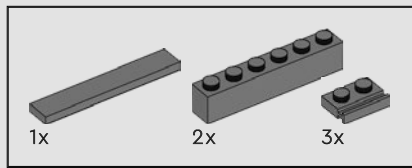

76

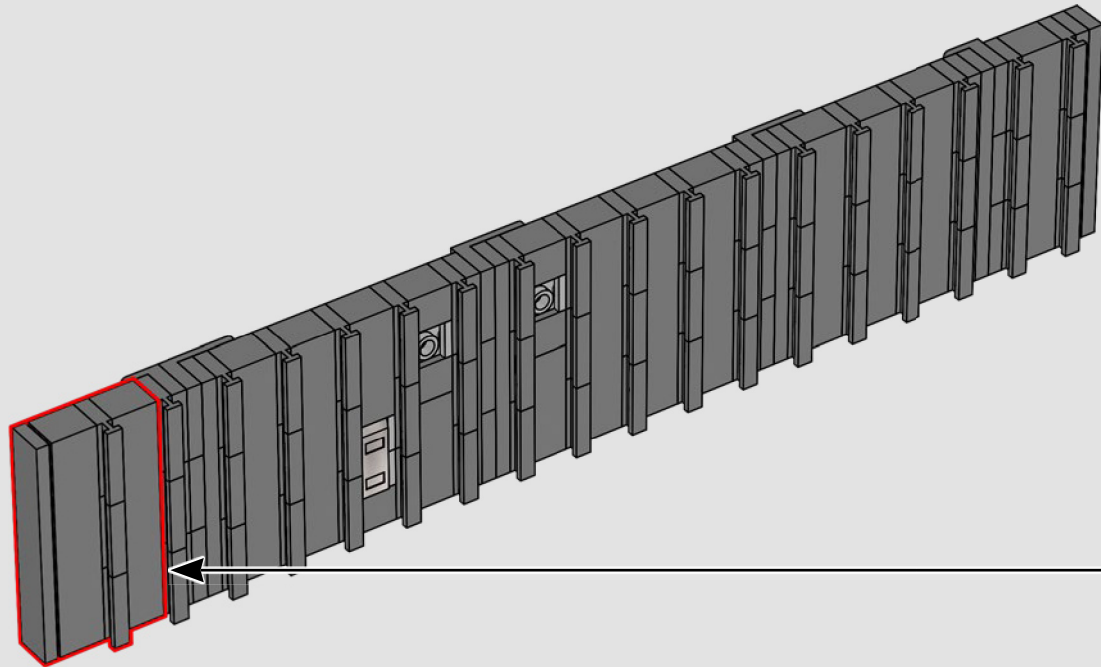
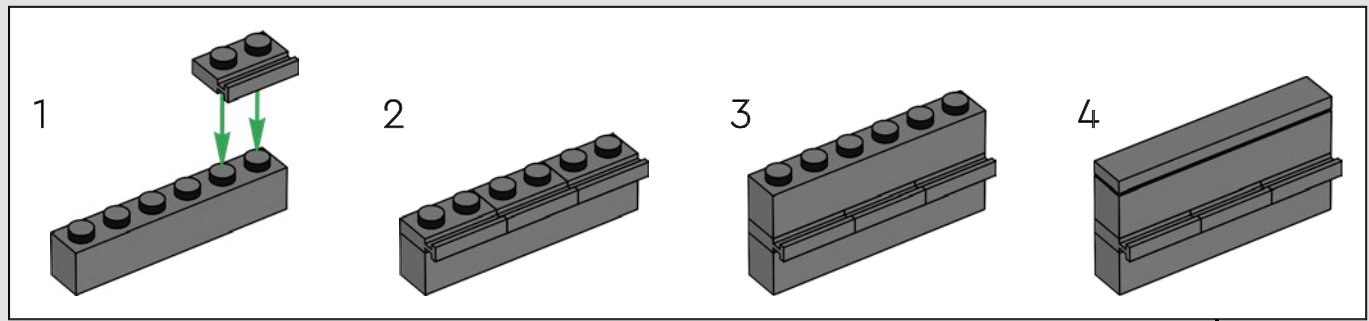

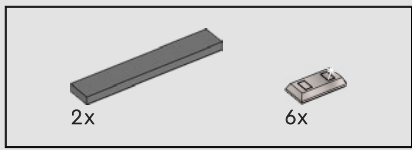

77

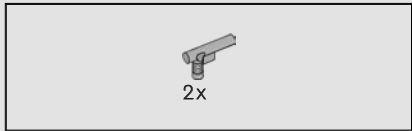
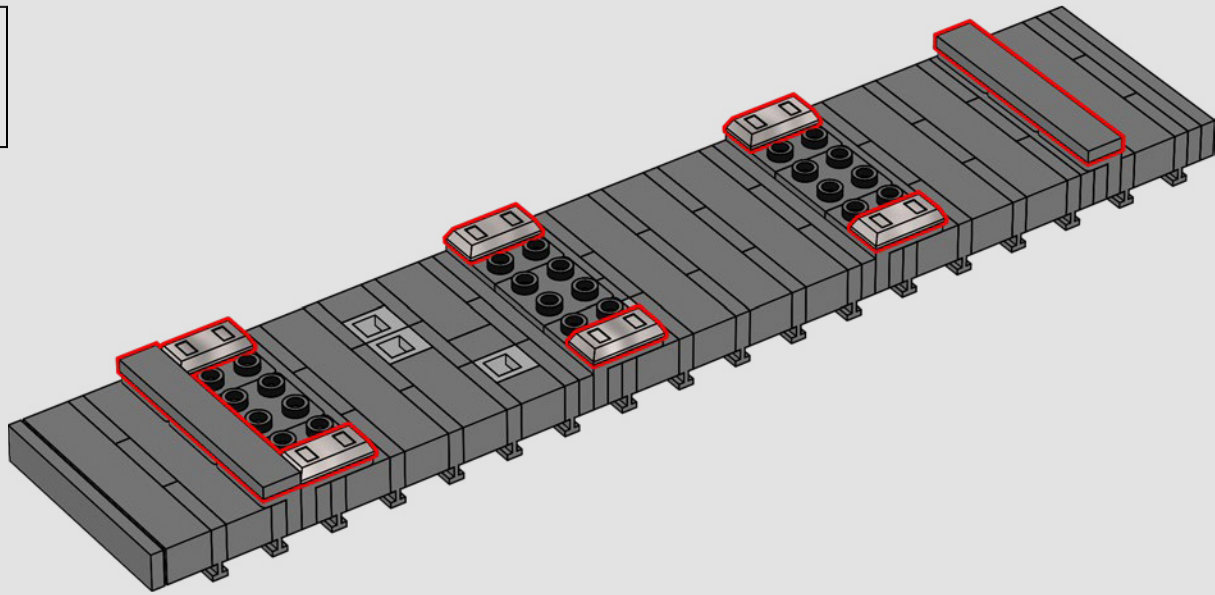

78

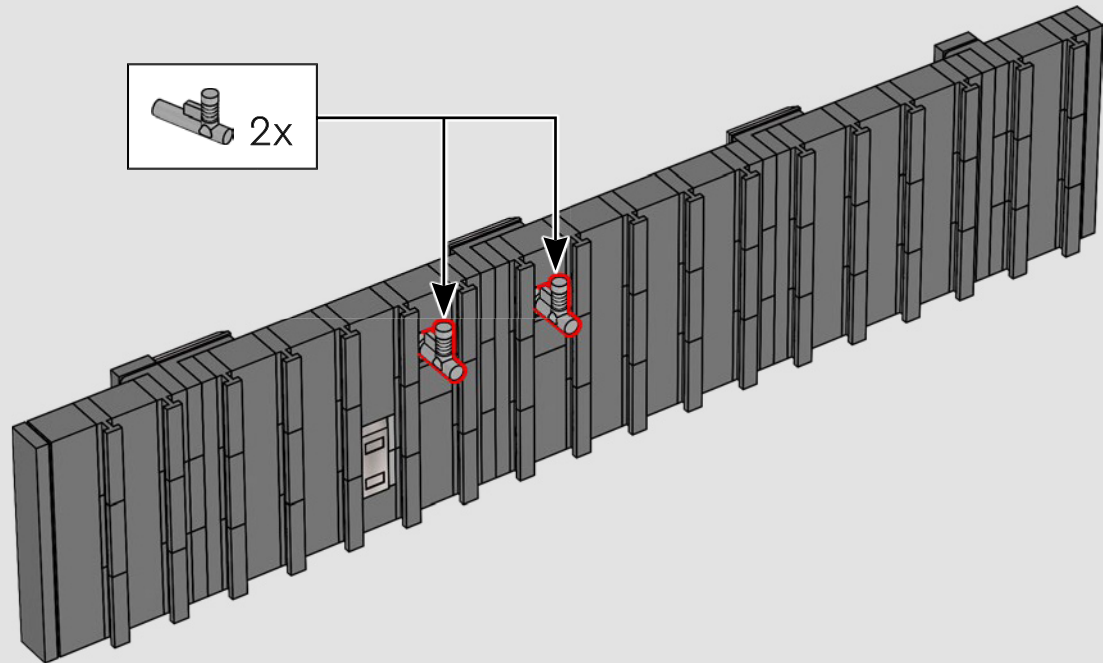
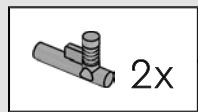

79

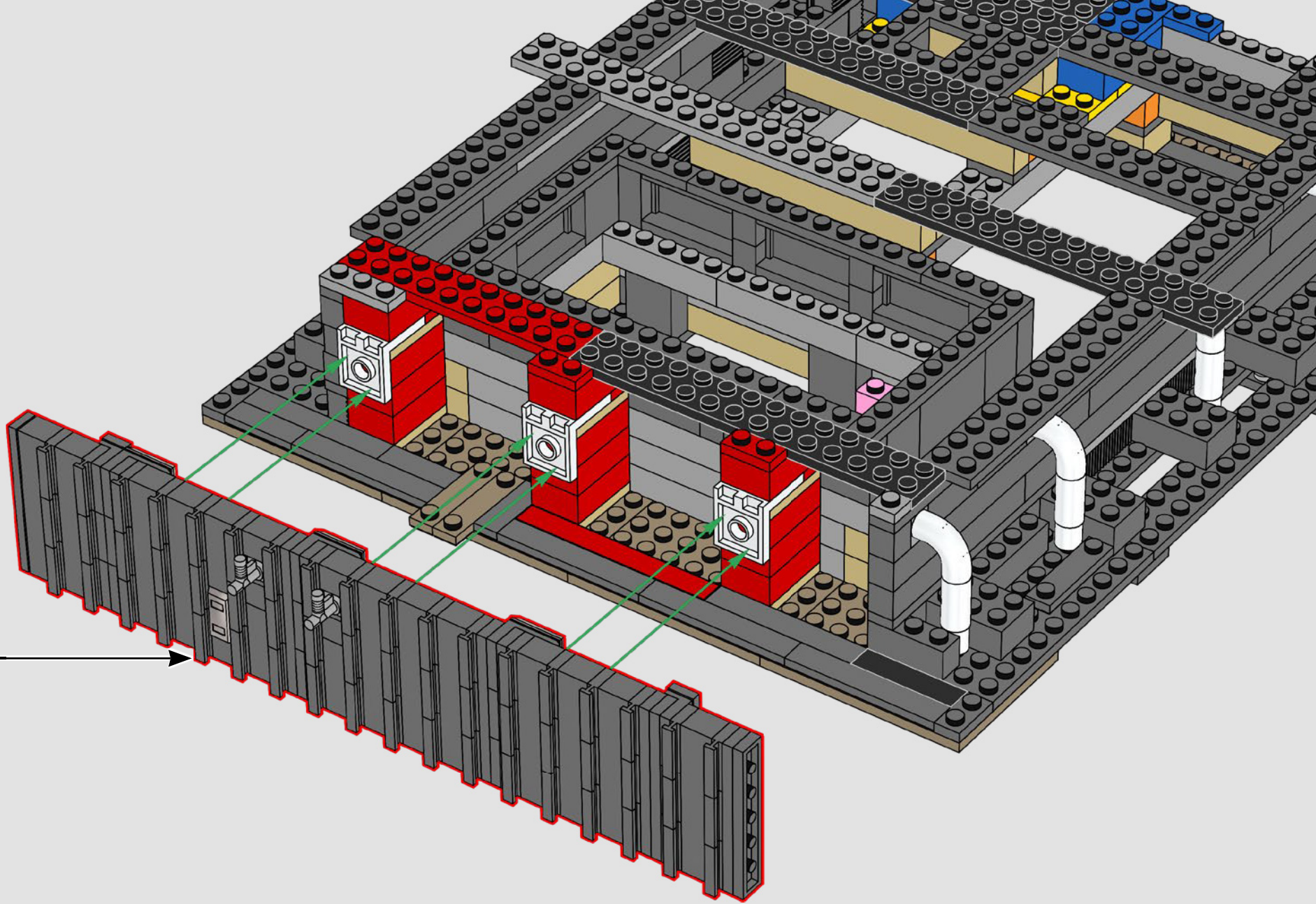

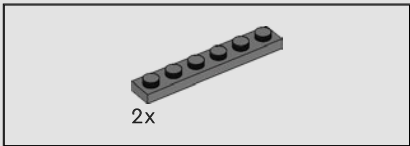
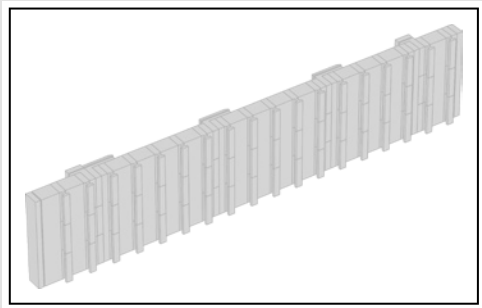

80

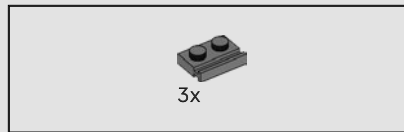
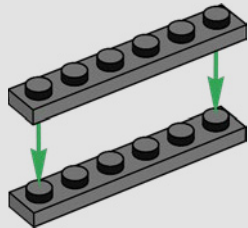

81

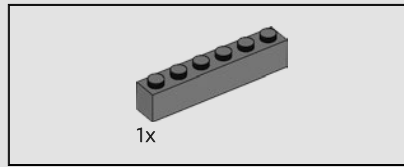
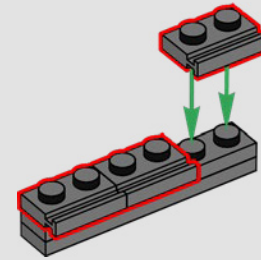

82

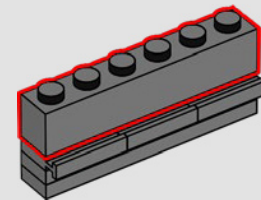

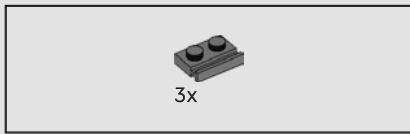

83

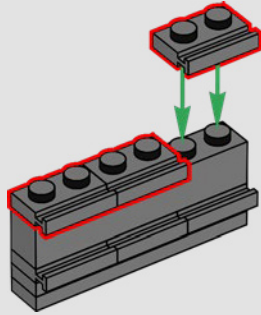

84

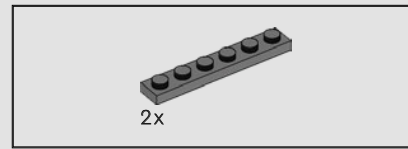
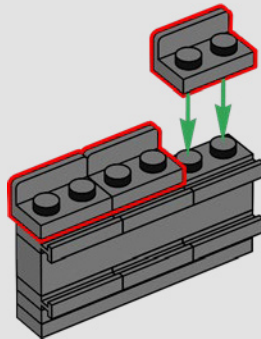

85

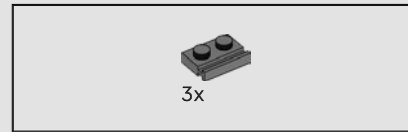
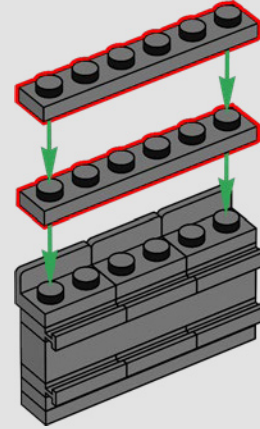

86

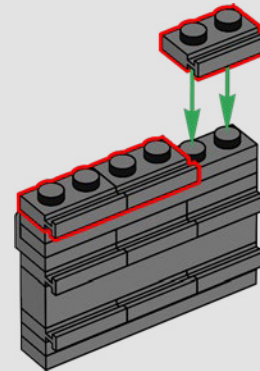

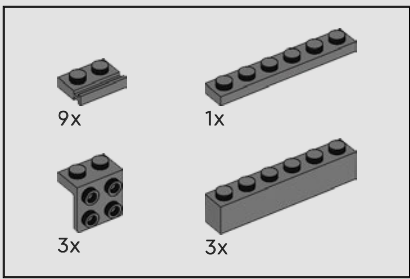

87

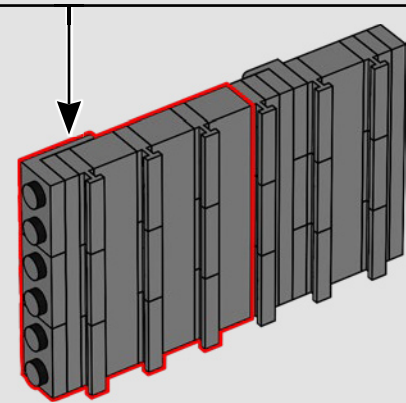
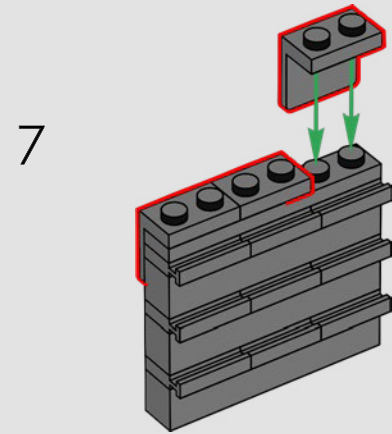
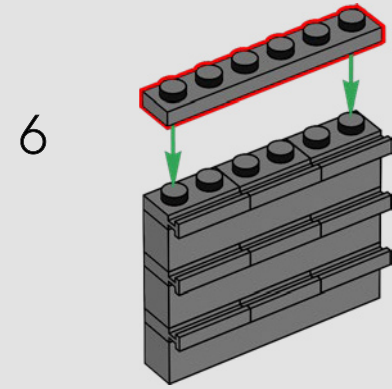
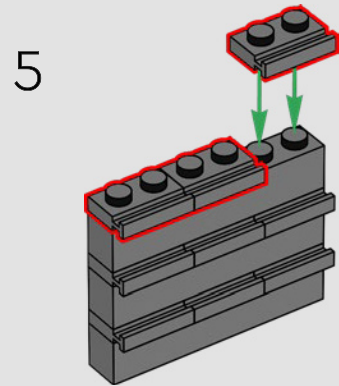
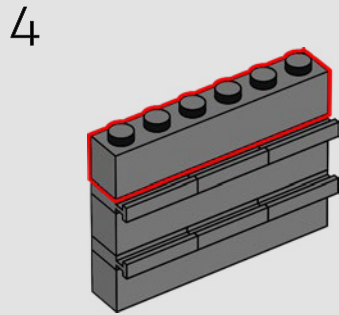
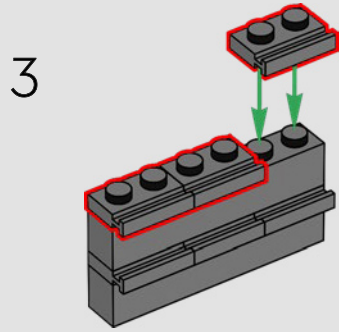
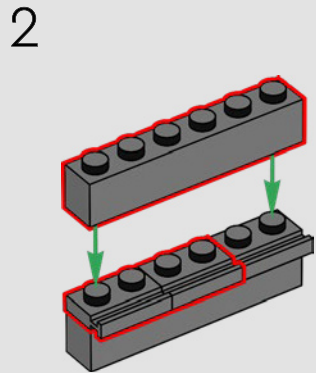
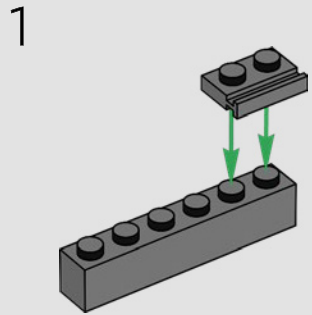

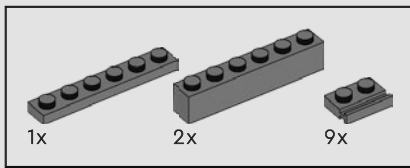

88

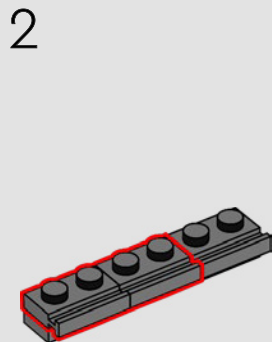
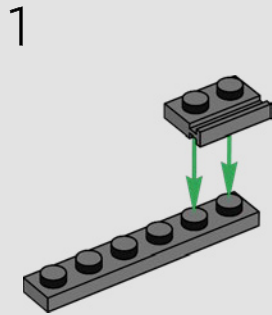

3

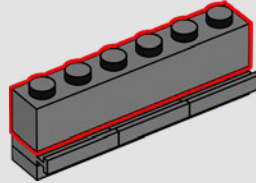

4

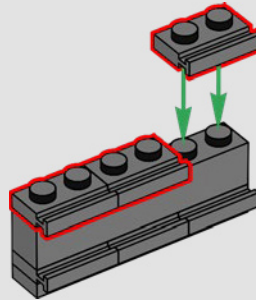

5

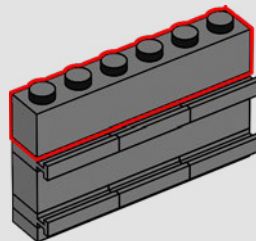

6

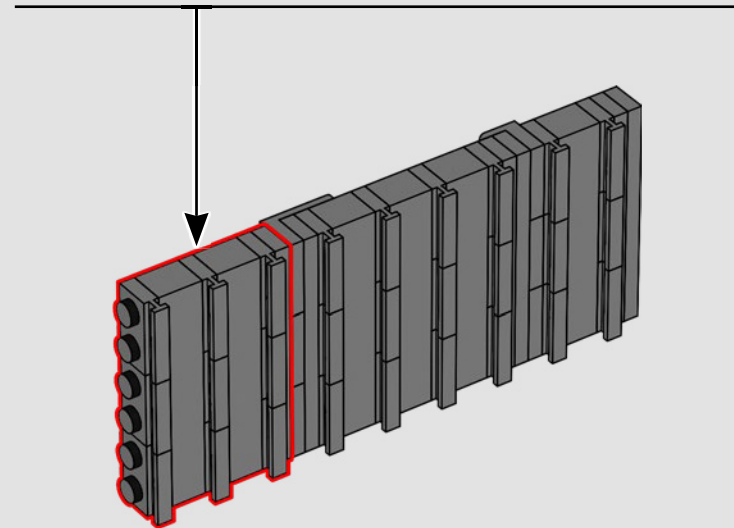
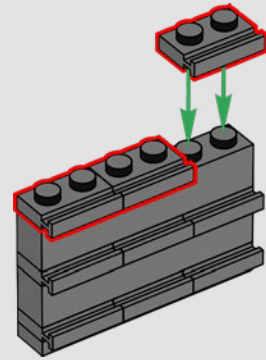

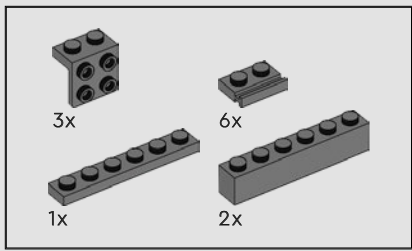

89

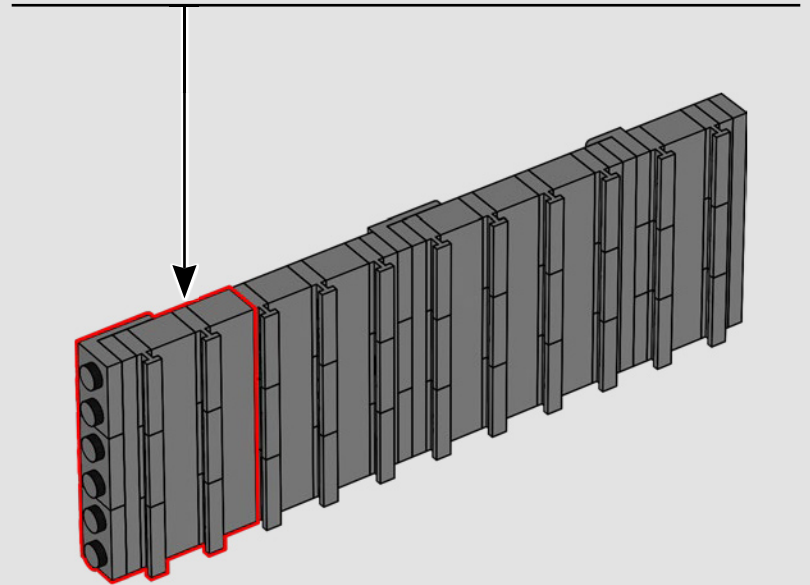
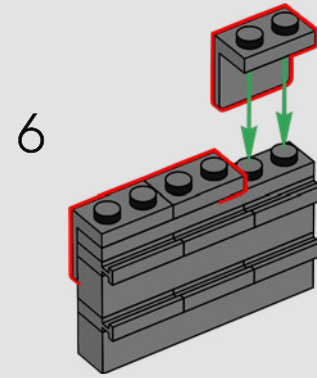
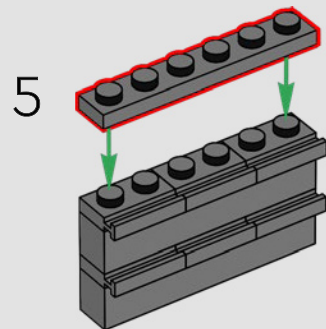
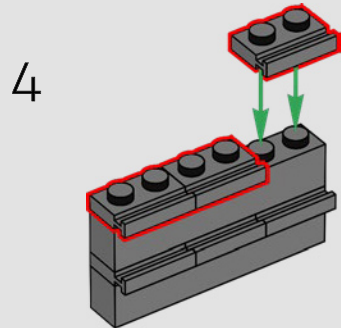
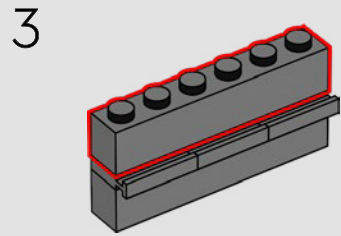
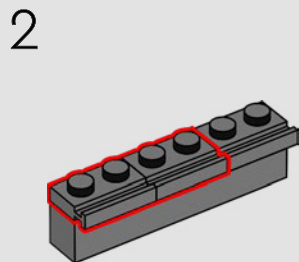
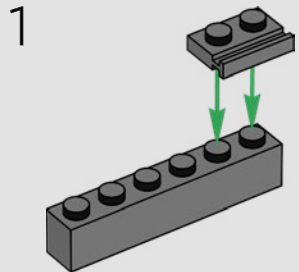

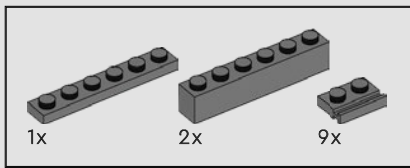

90

1

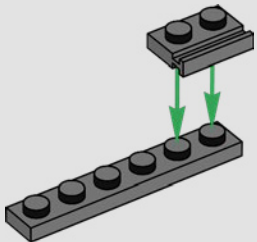

2

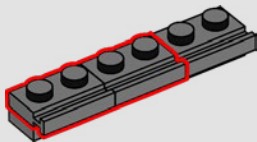

3

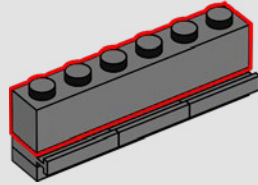

4

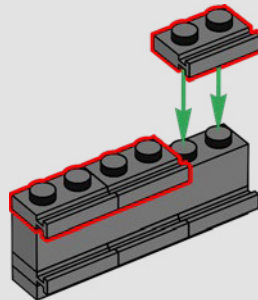

5

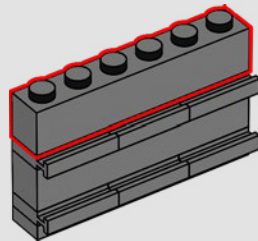

6

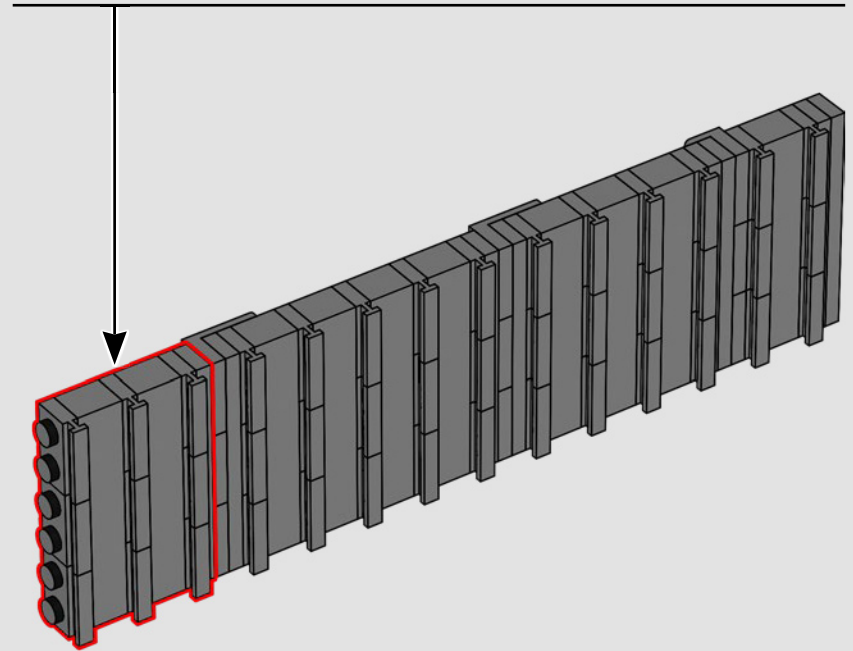
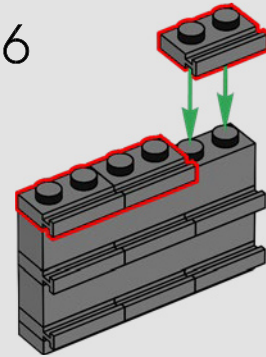

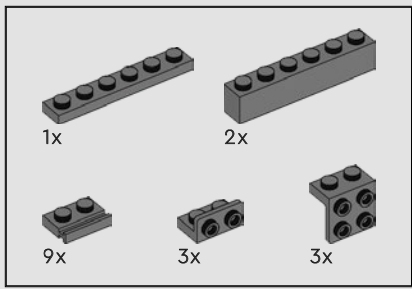

91

1

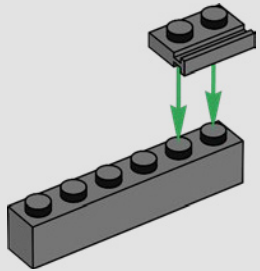

2

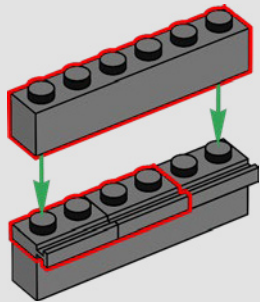

3

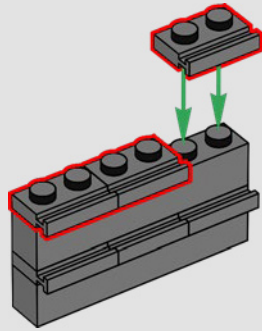

4

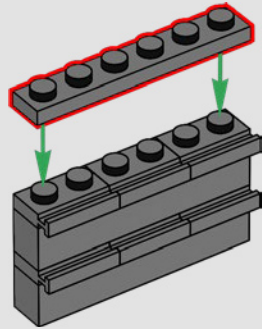

5

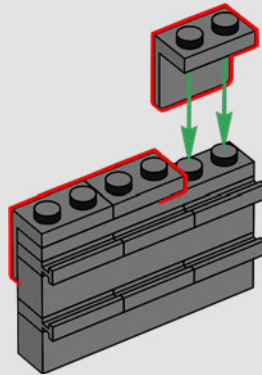

6

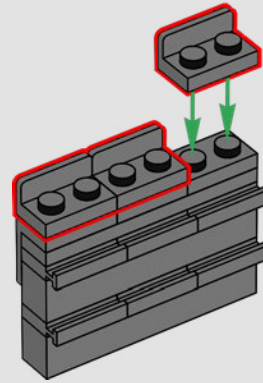

7

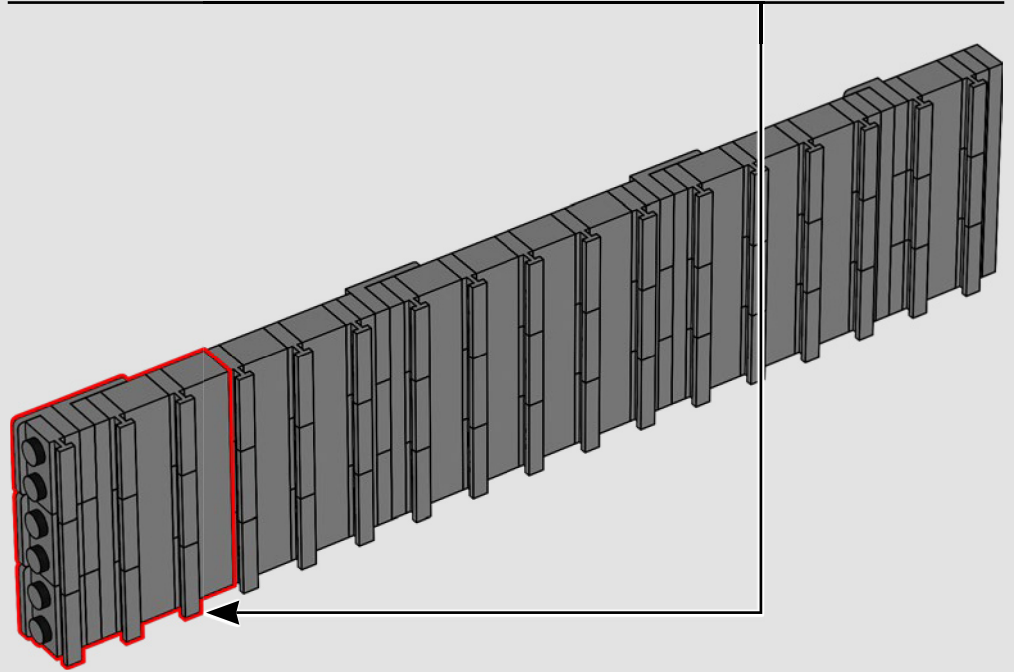
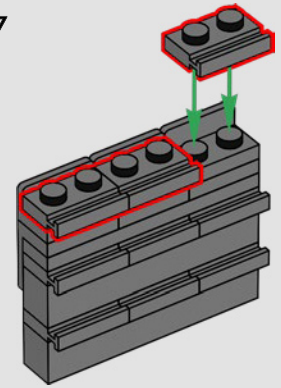

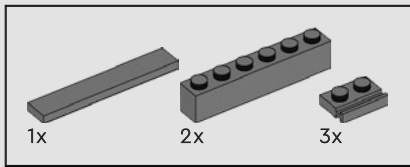

92

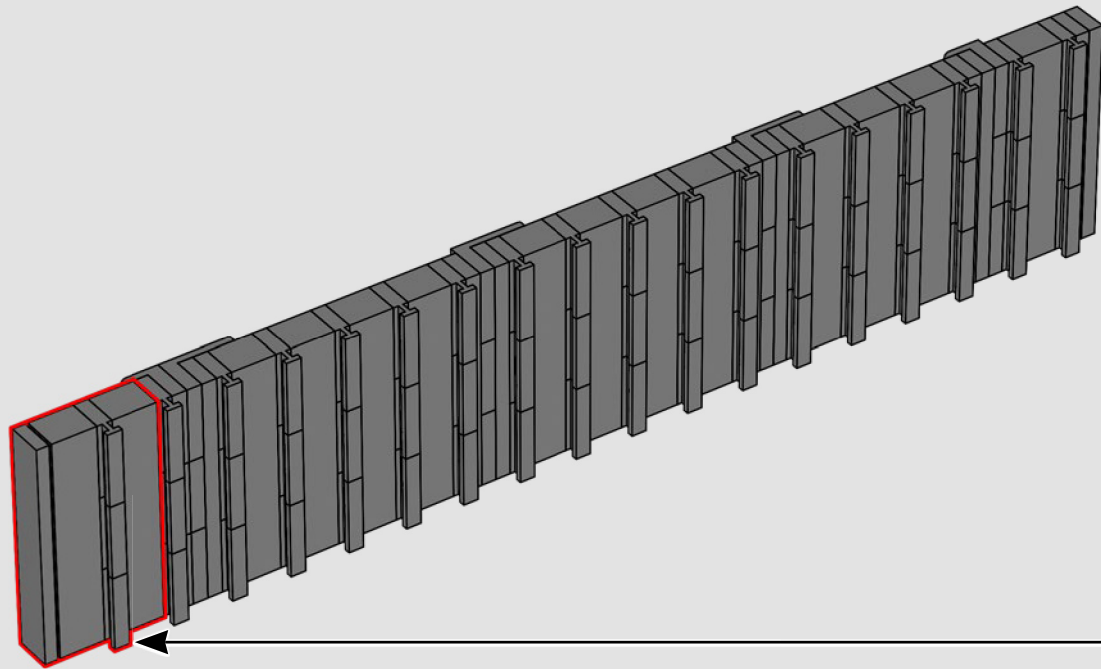
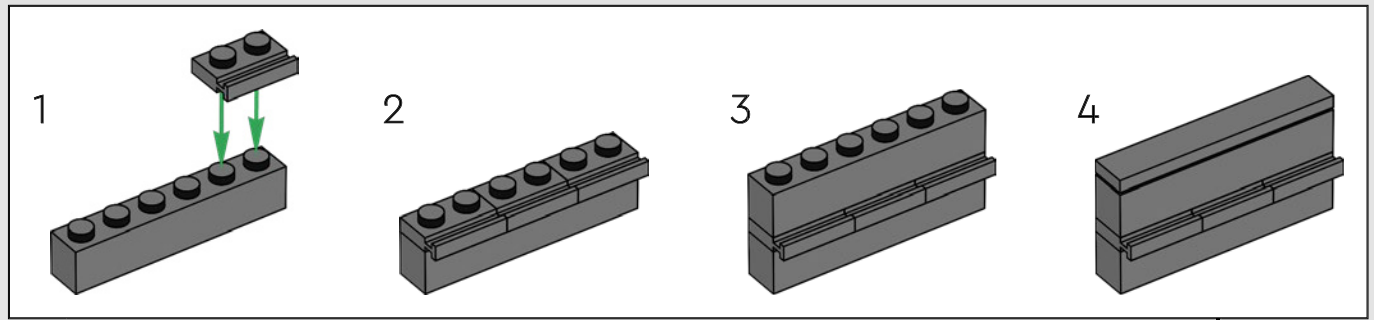

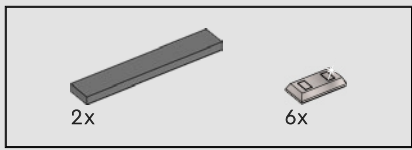

93

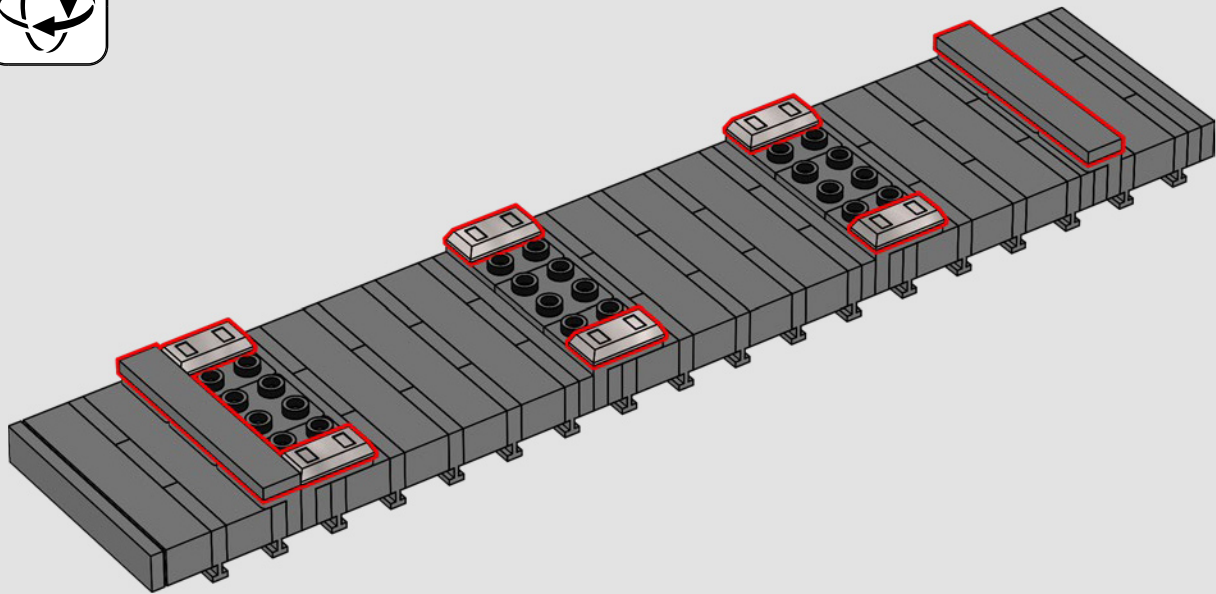

94

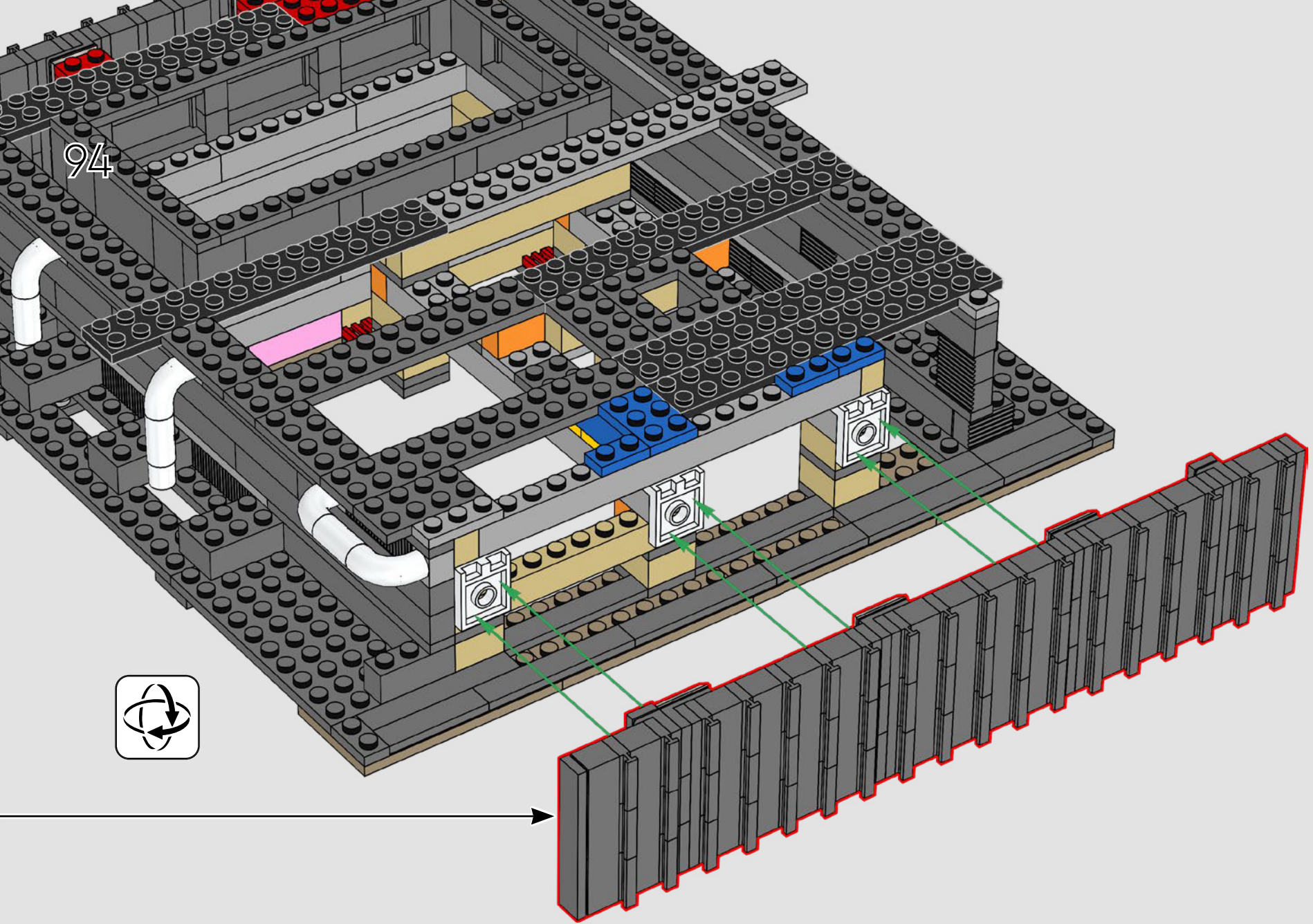

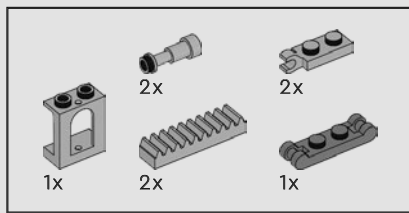

95

1

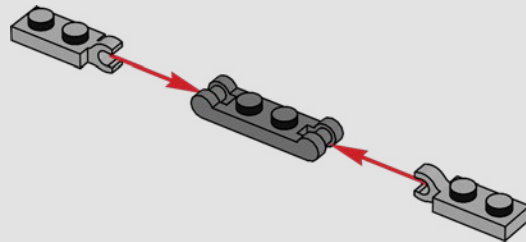

2

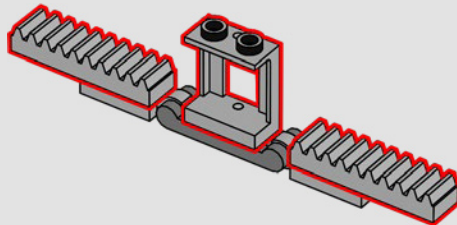

3

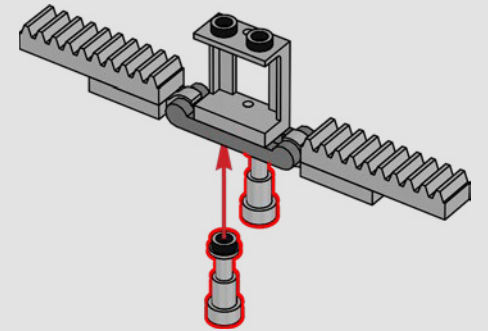

4

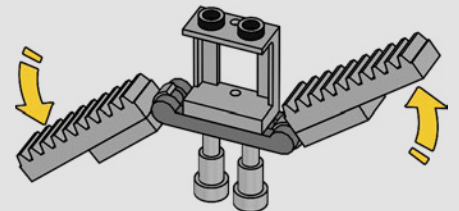

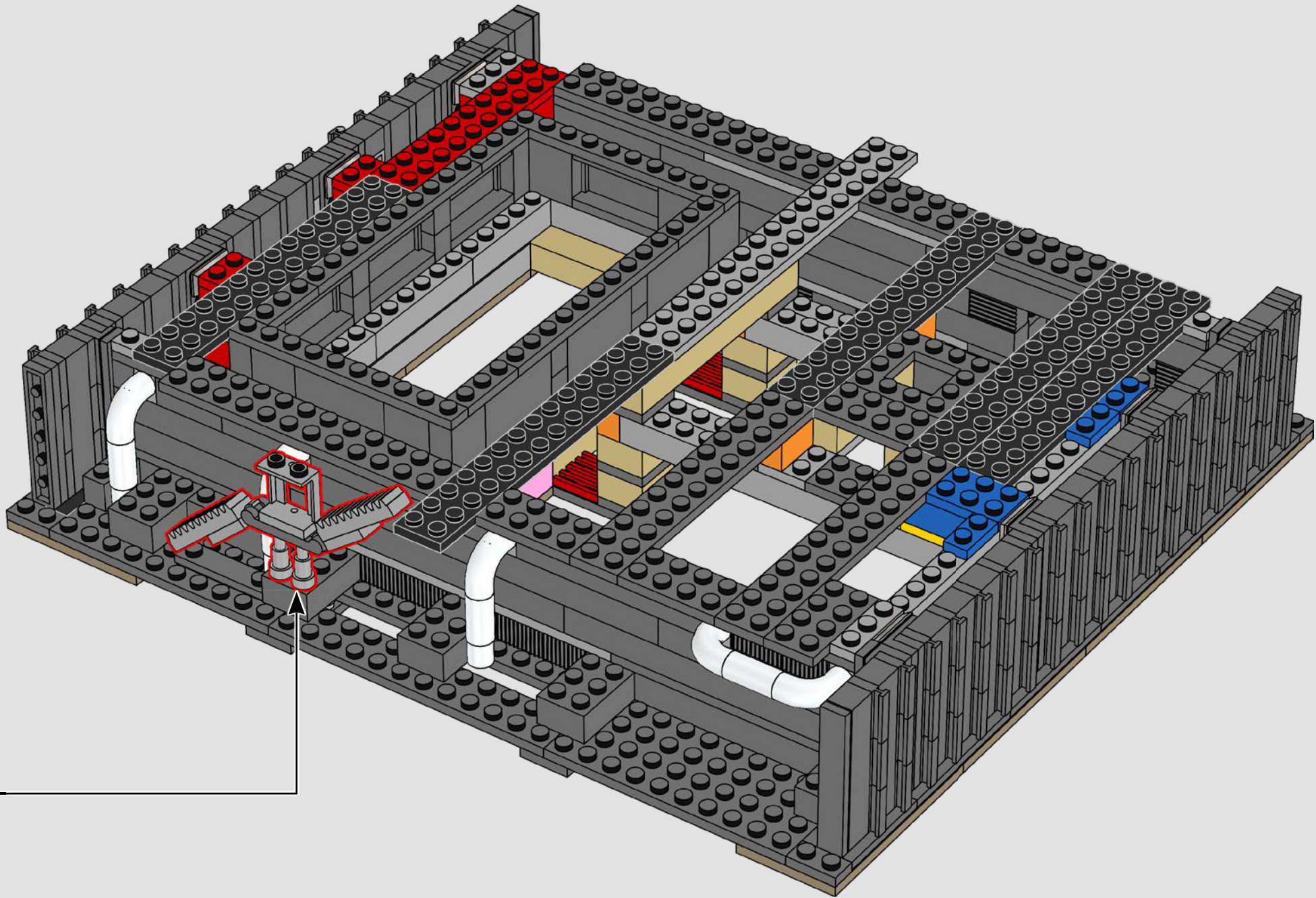

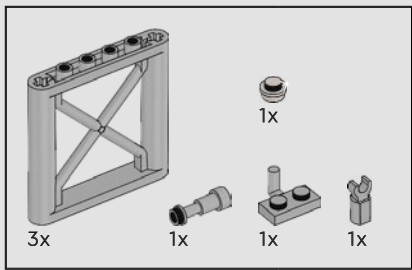

96

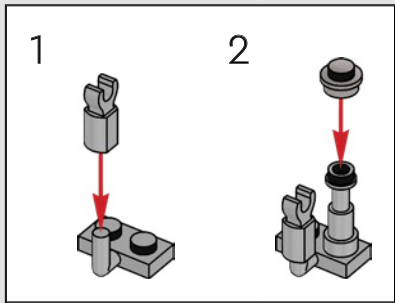
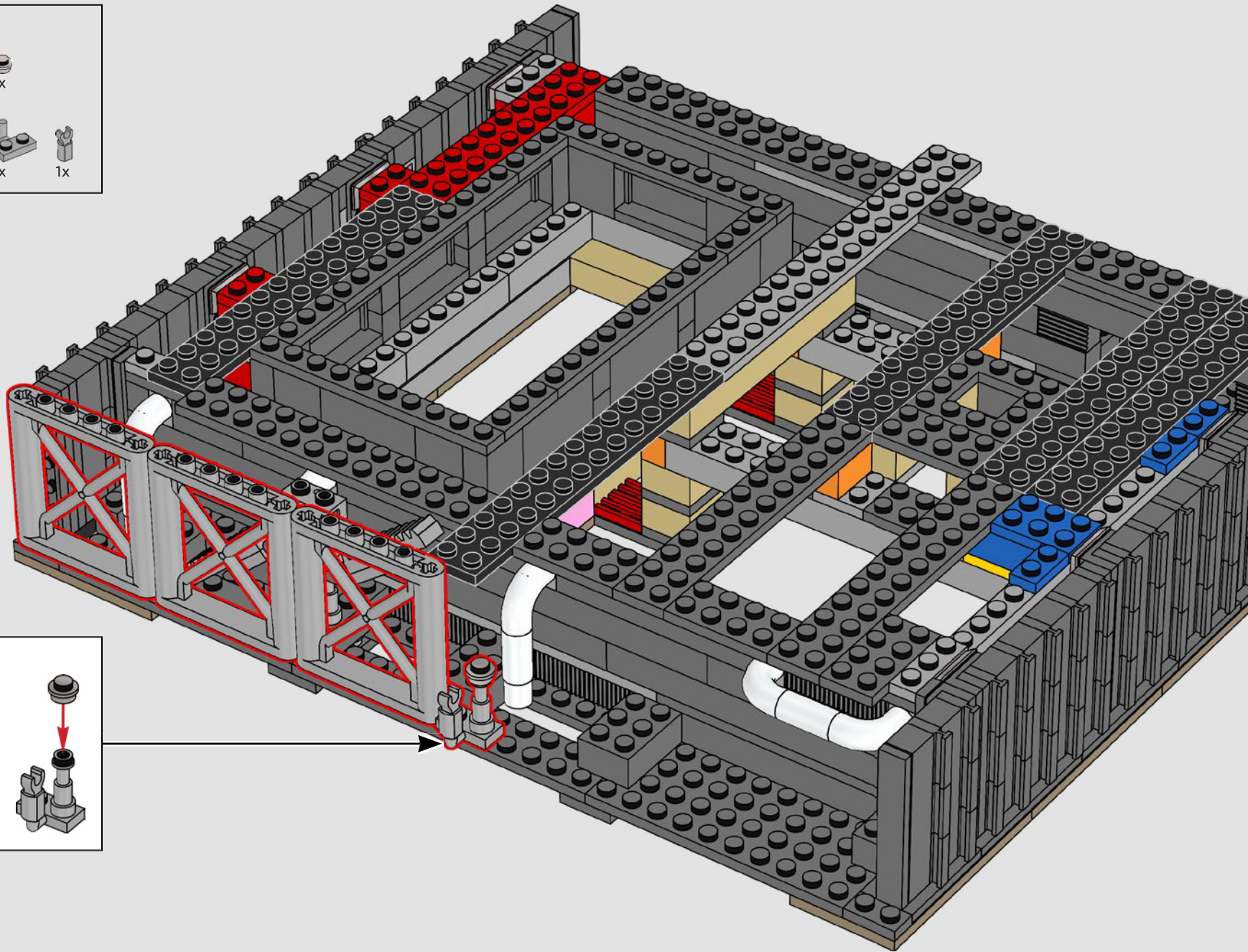

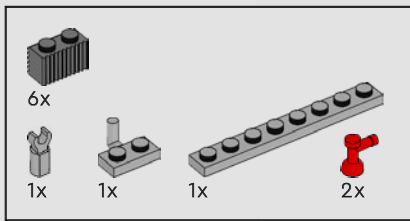

97

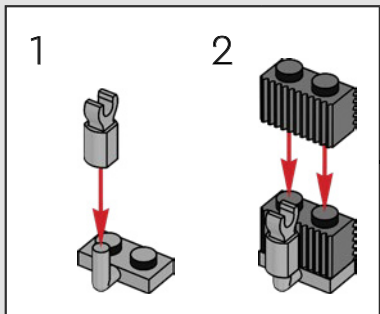
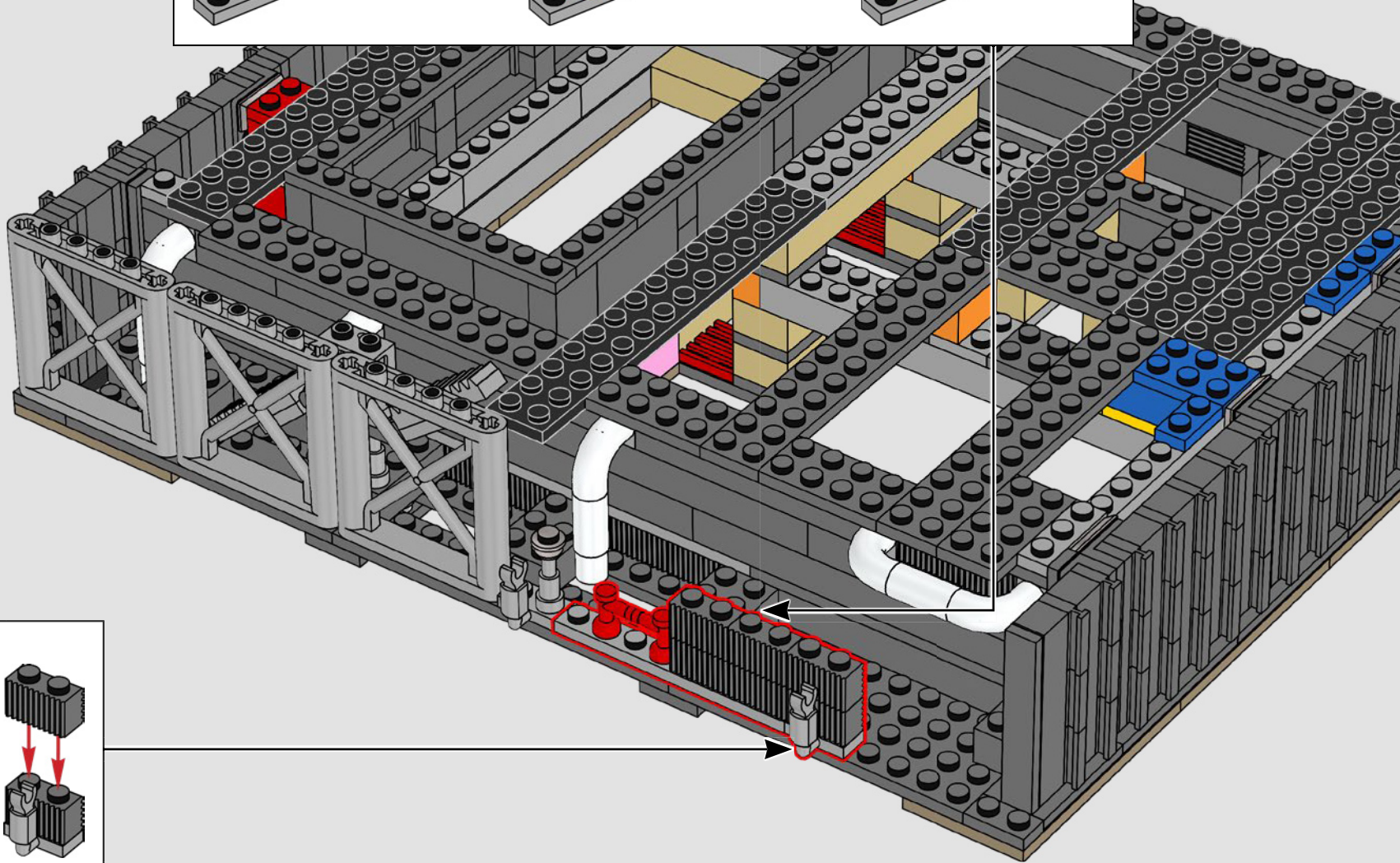
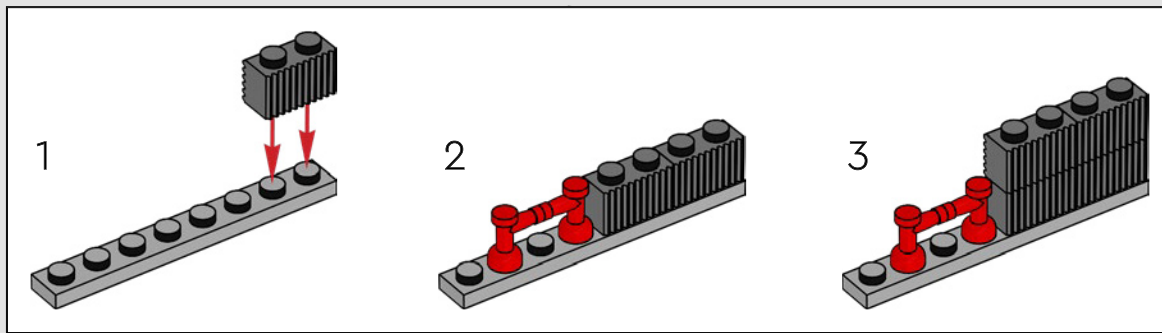

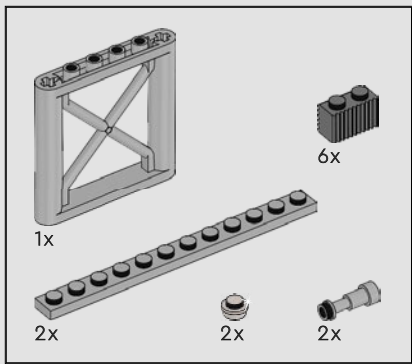

98

1

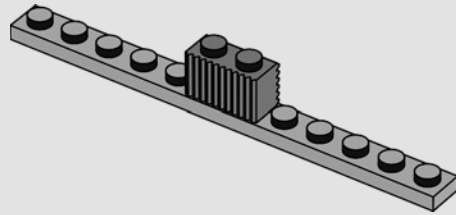

2

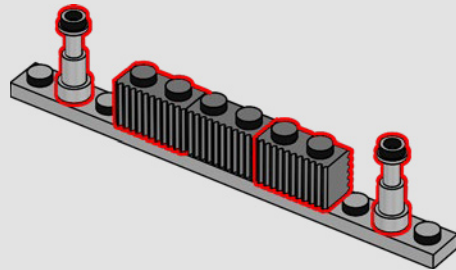

3

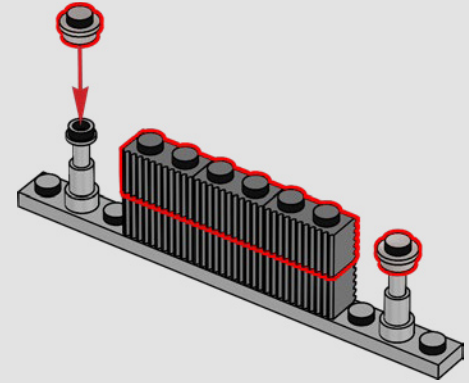

4

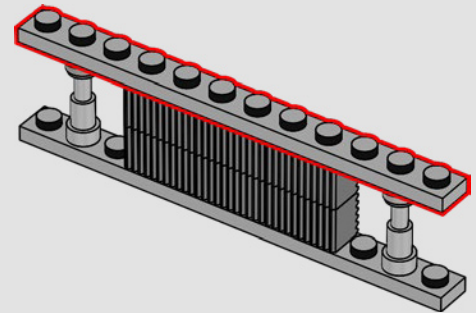

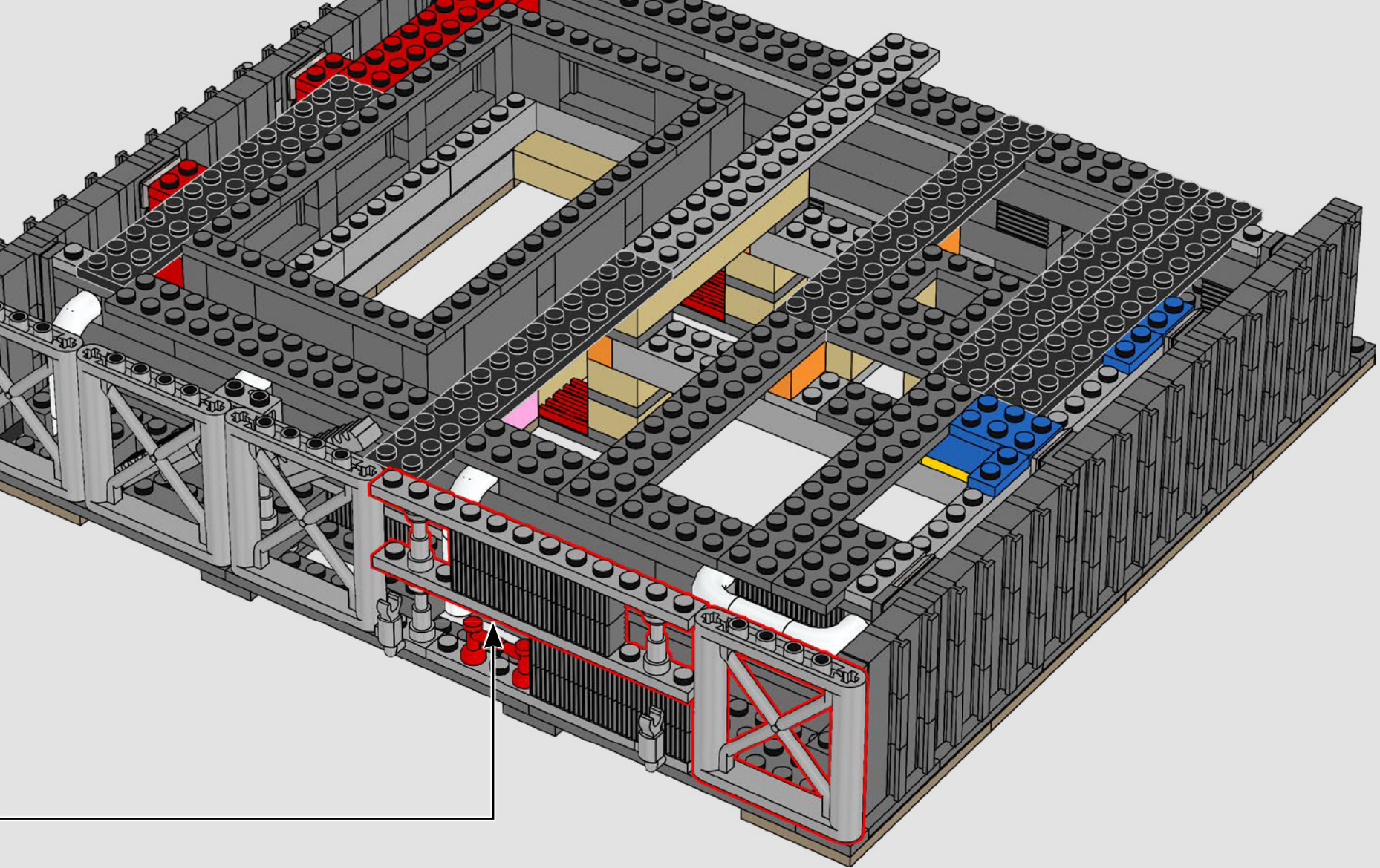

Im Gegensatz zum echten Space Shuttle-Starttisch verfügt die LEGO® SLS-Plattform über teilweise offene Seiten, durch die Details wie Rohre und Treppen sichtbar sind.

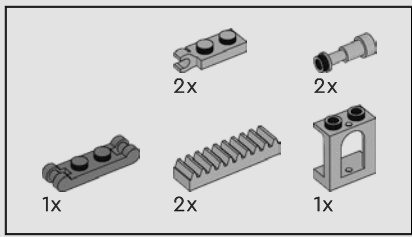

99

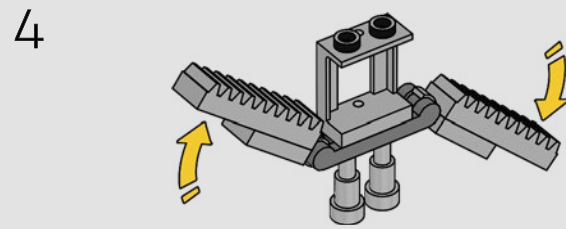
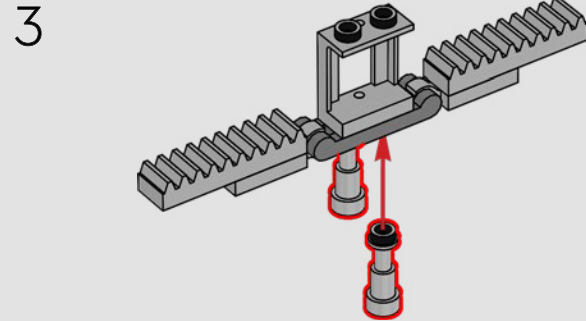
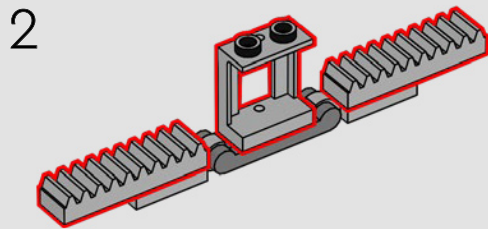
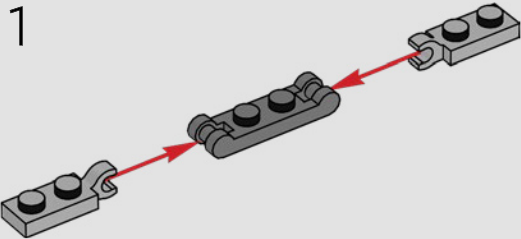

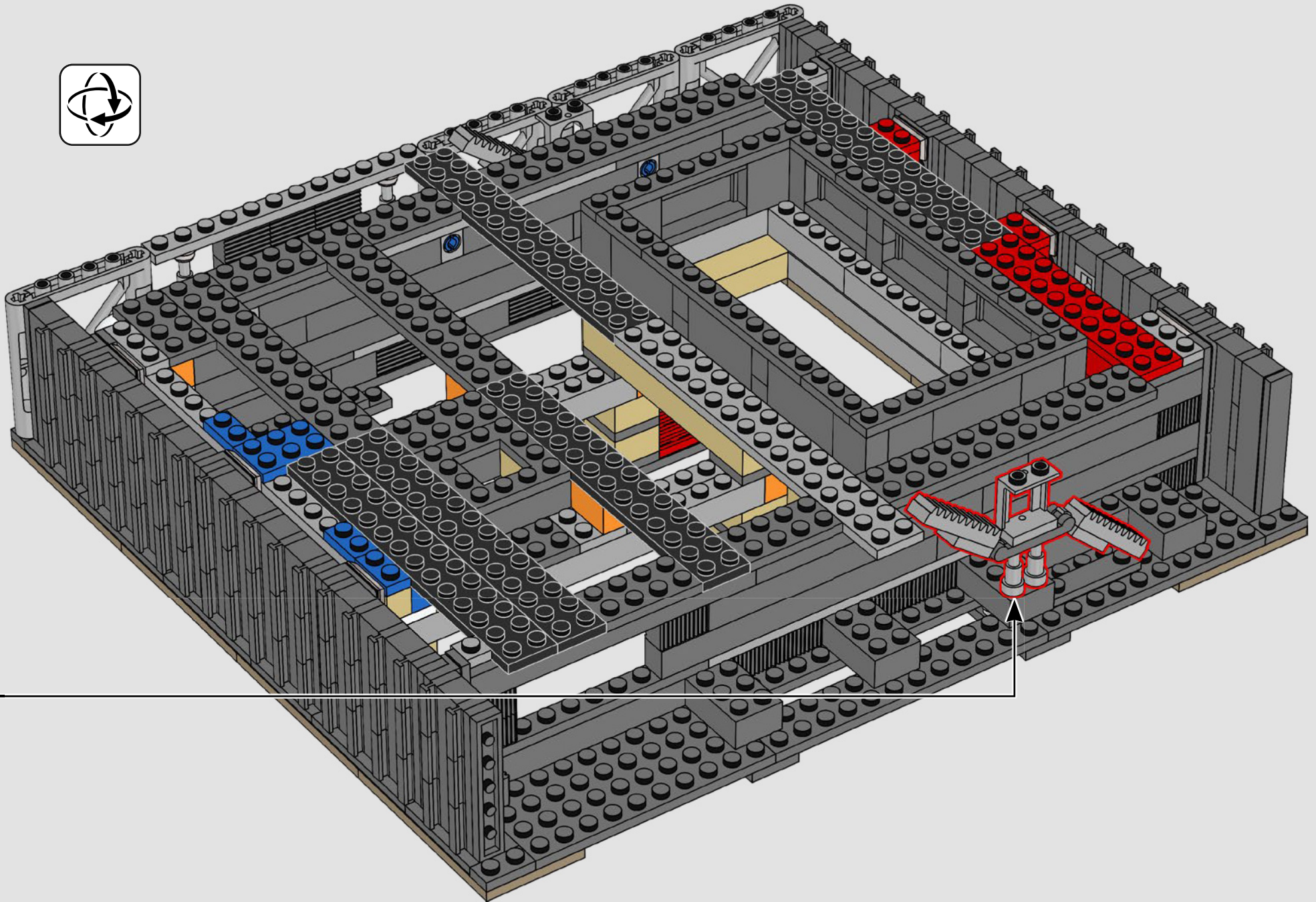

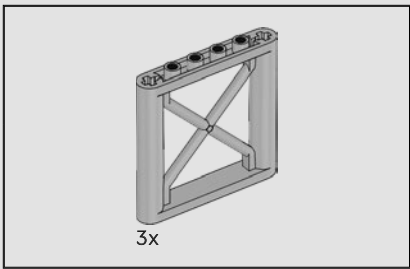

100

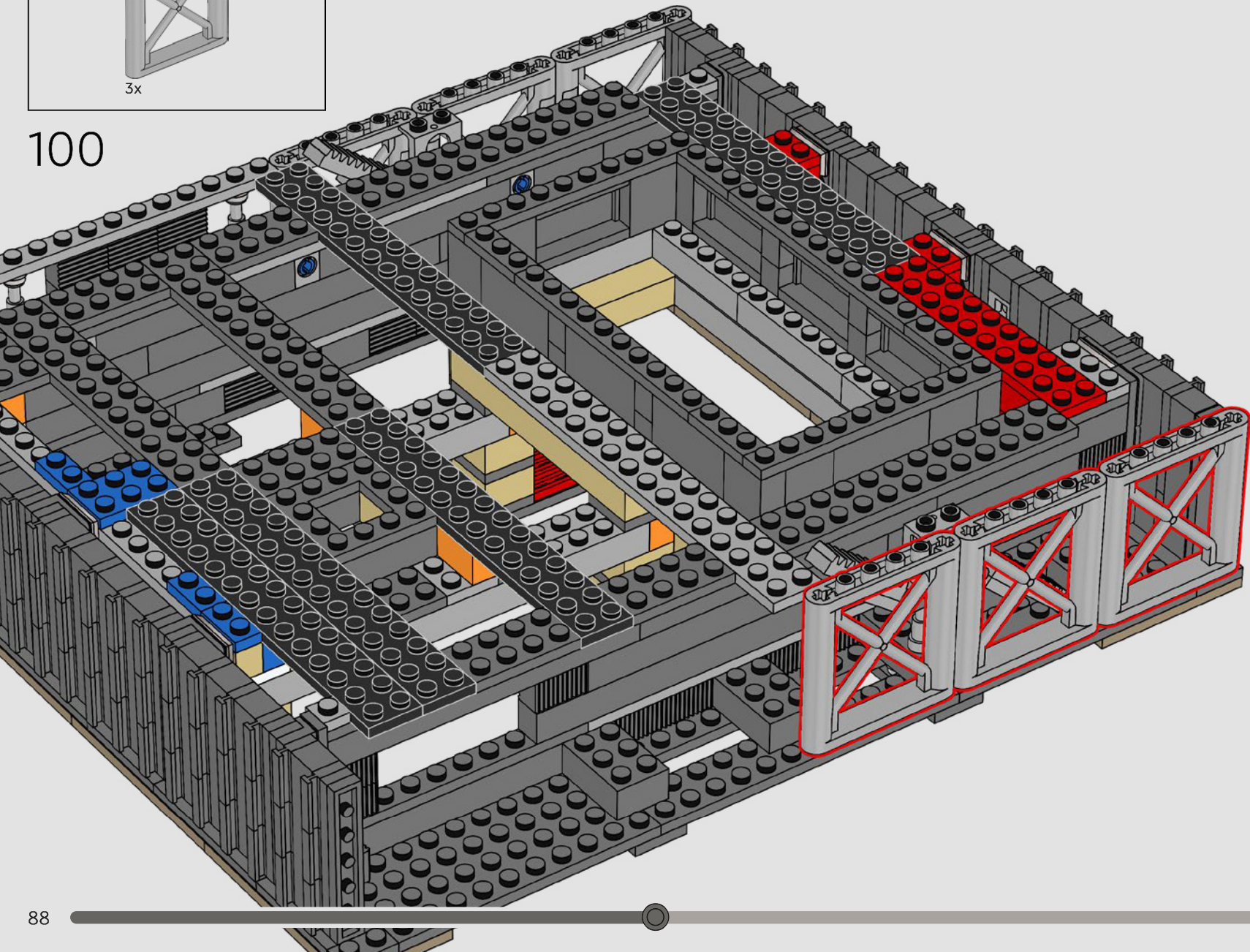

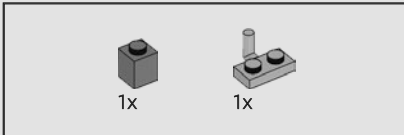
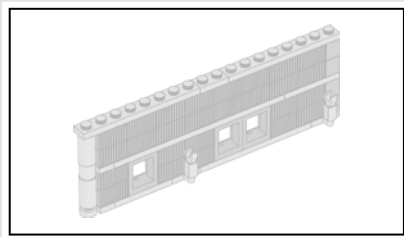

101

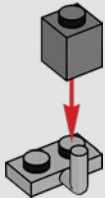

102

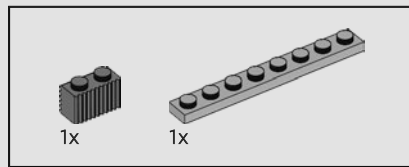
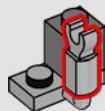

103

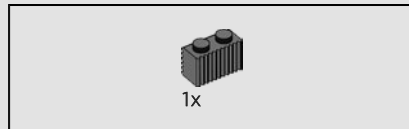
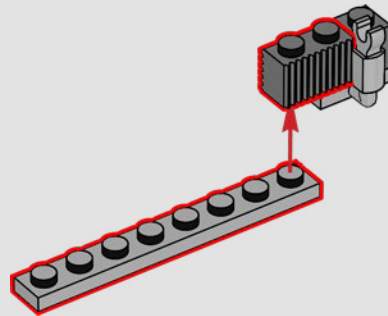

104

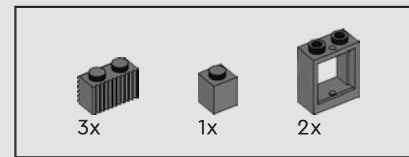
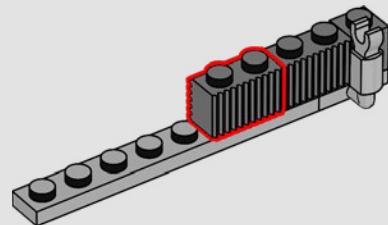

105

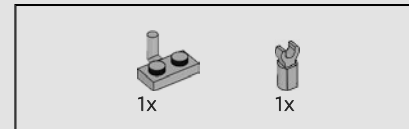
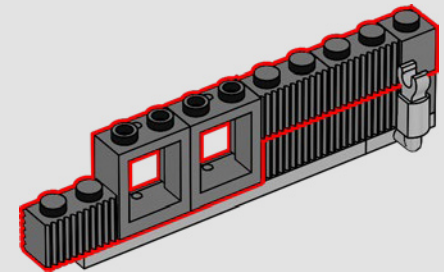

106

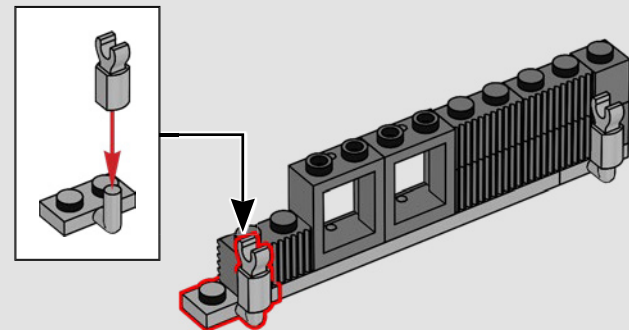

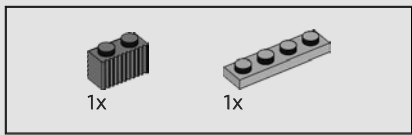

107

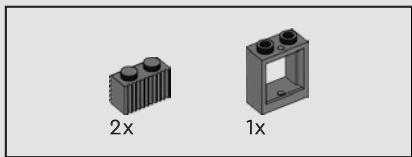
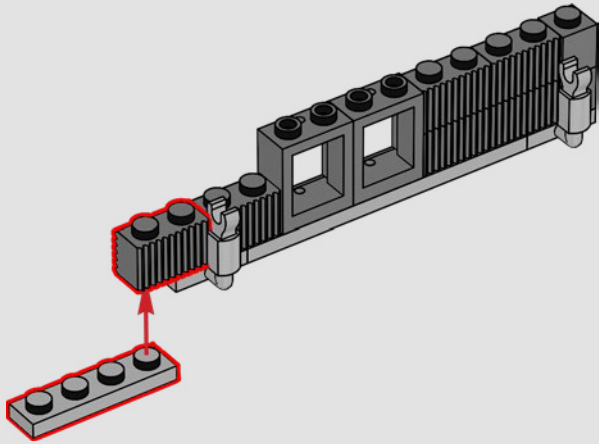

108

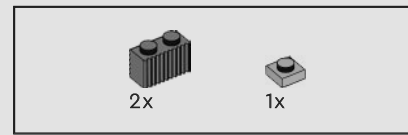
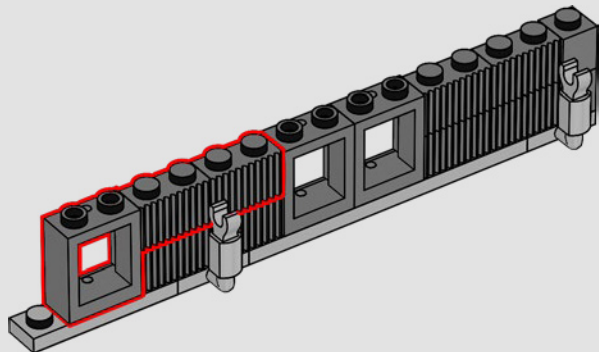

109

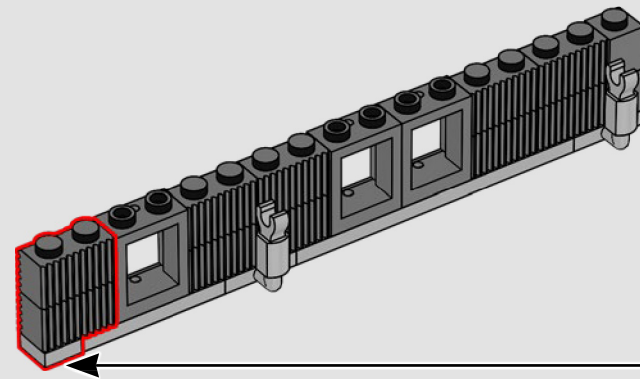
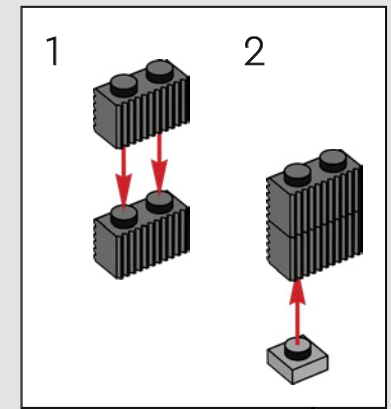

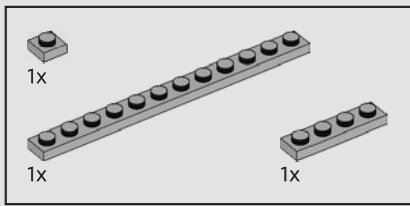

110

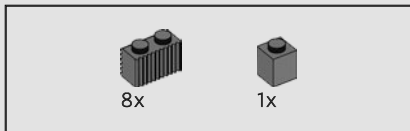
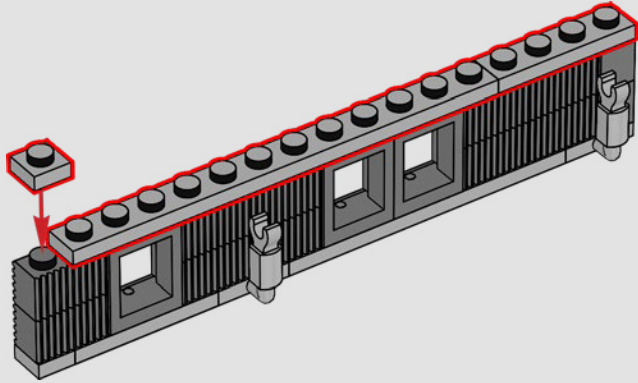

111

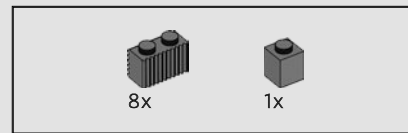
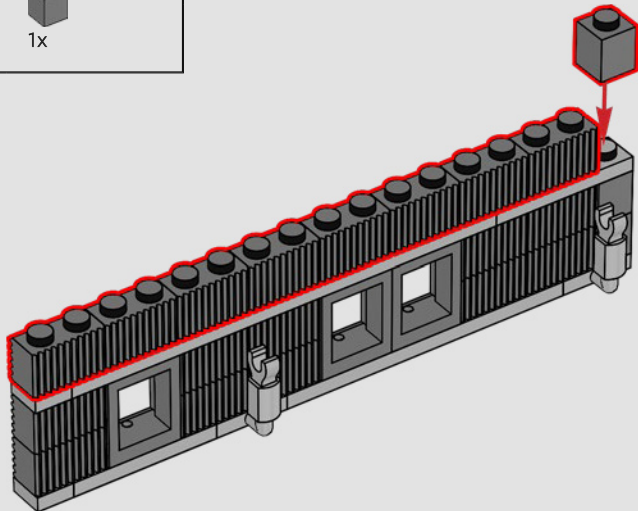

112

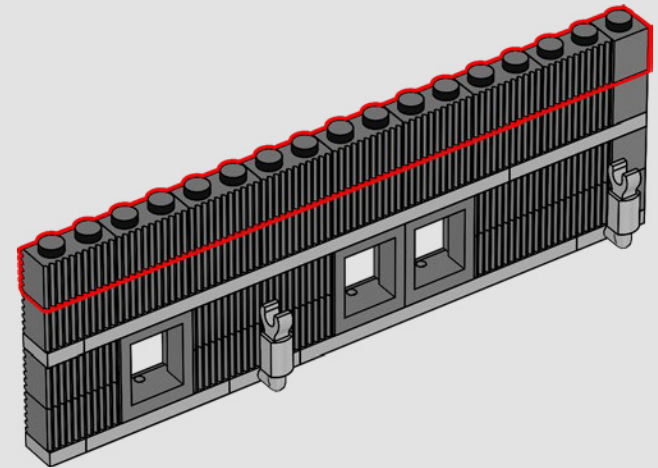

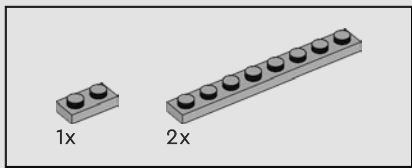

113

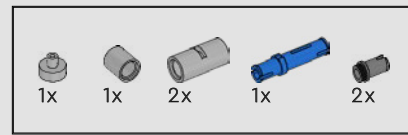
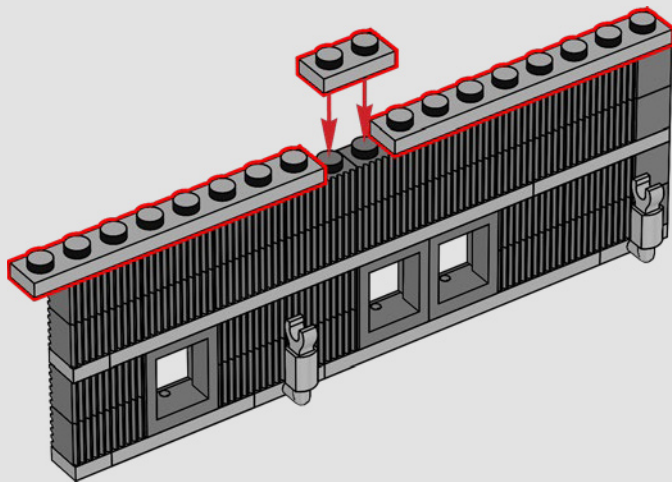

114

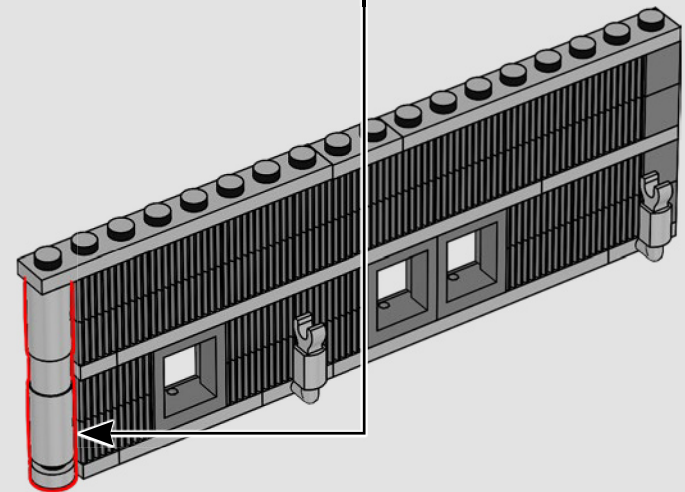
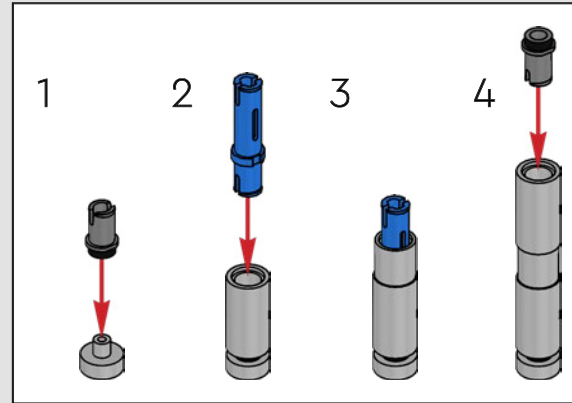

115

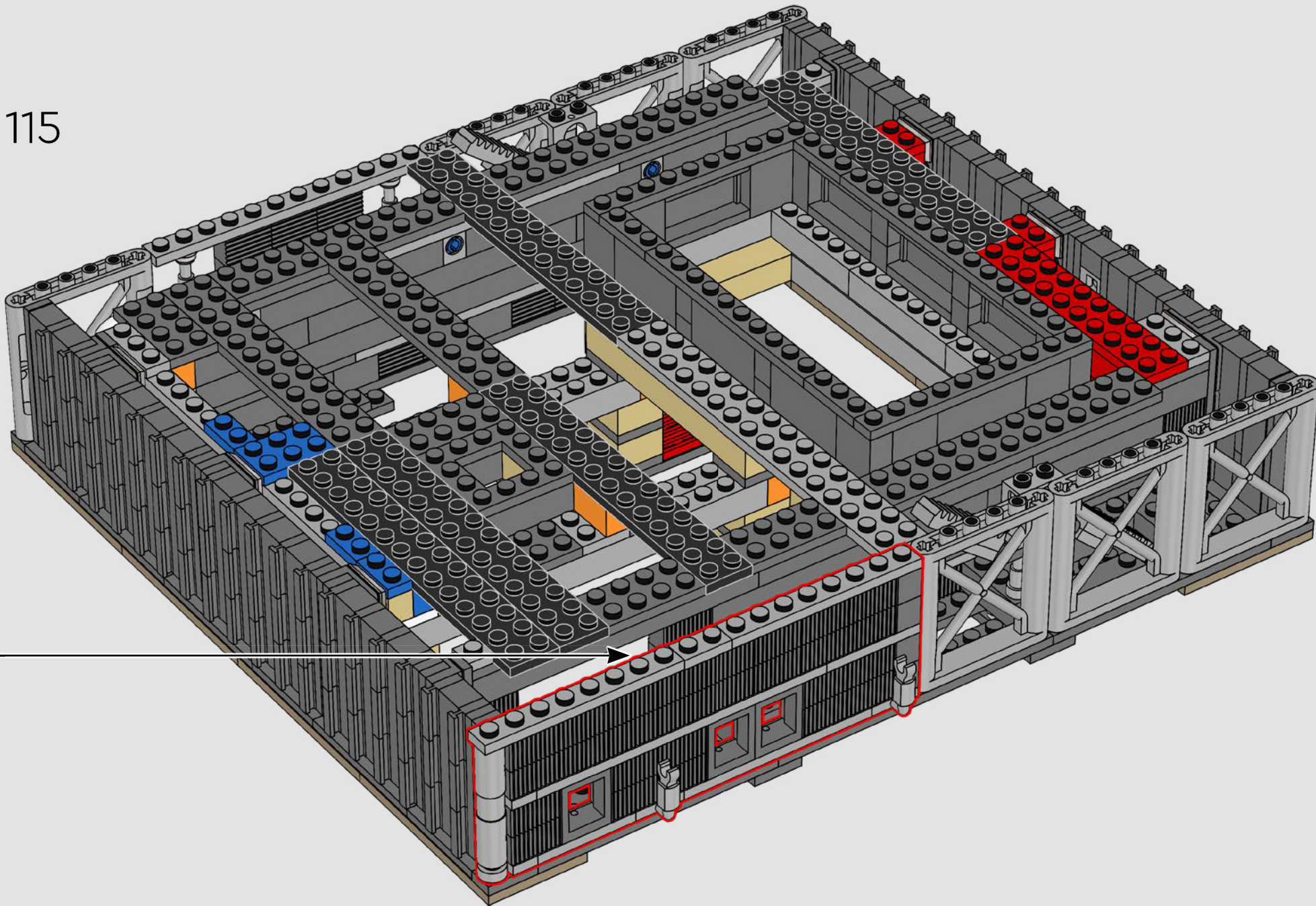

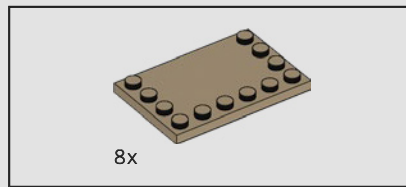

116

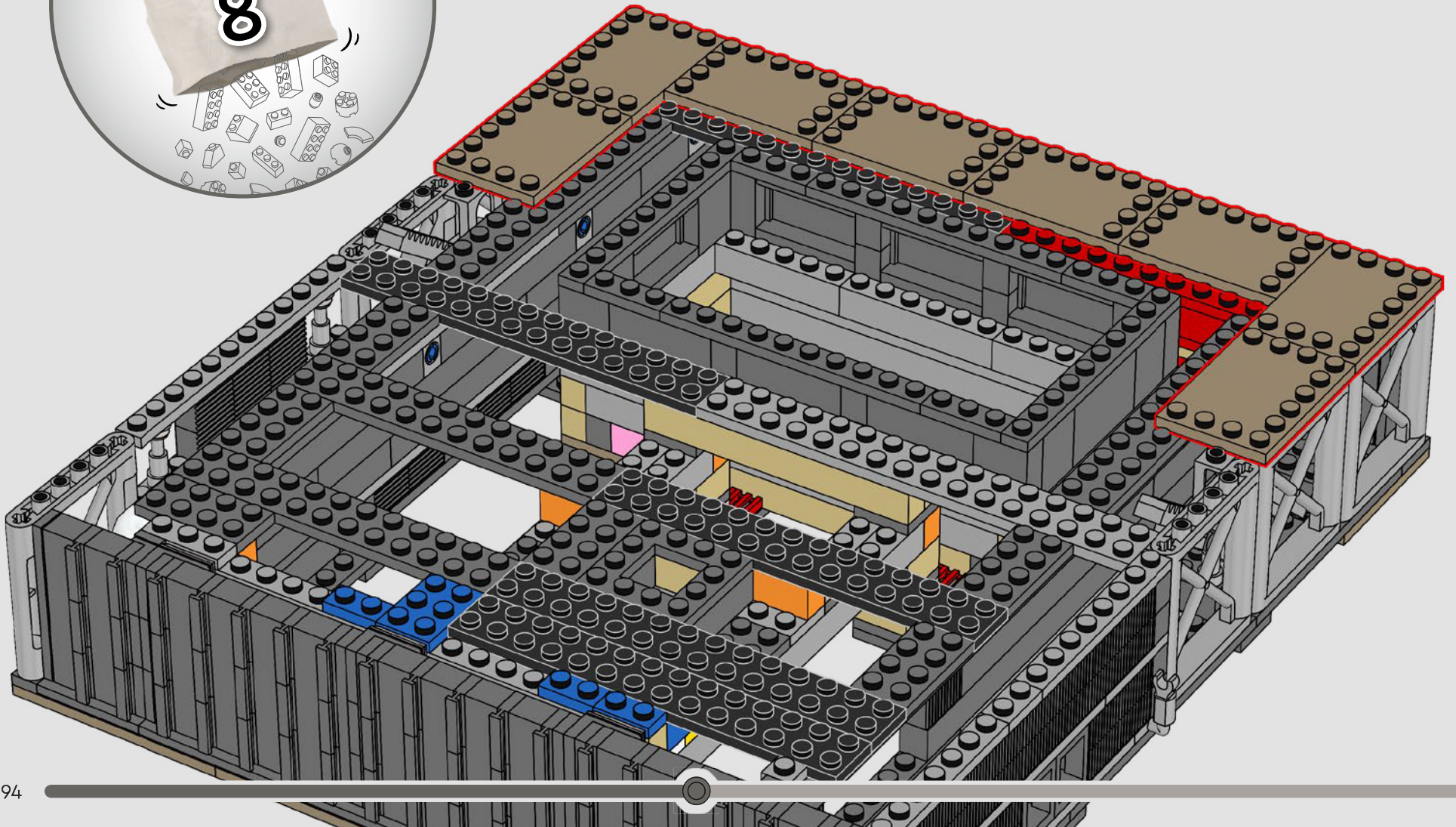

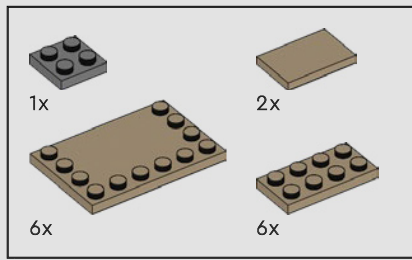

117

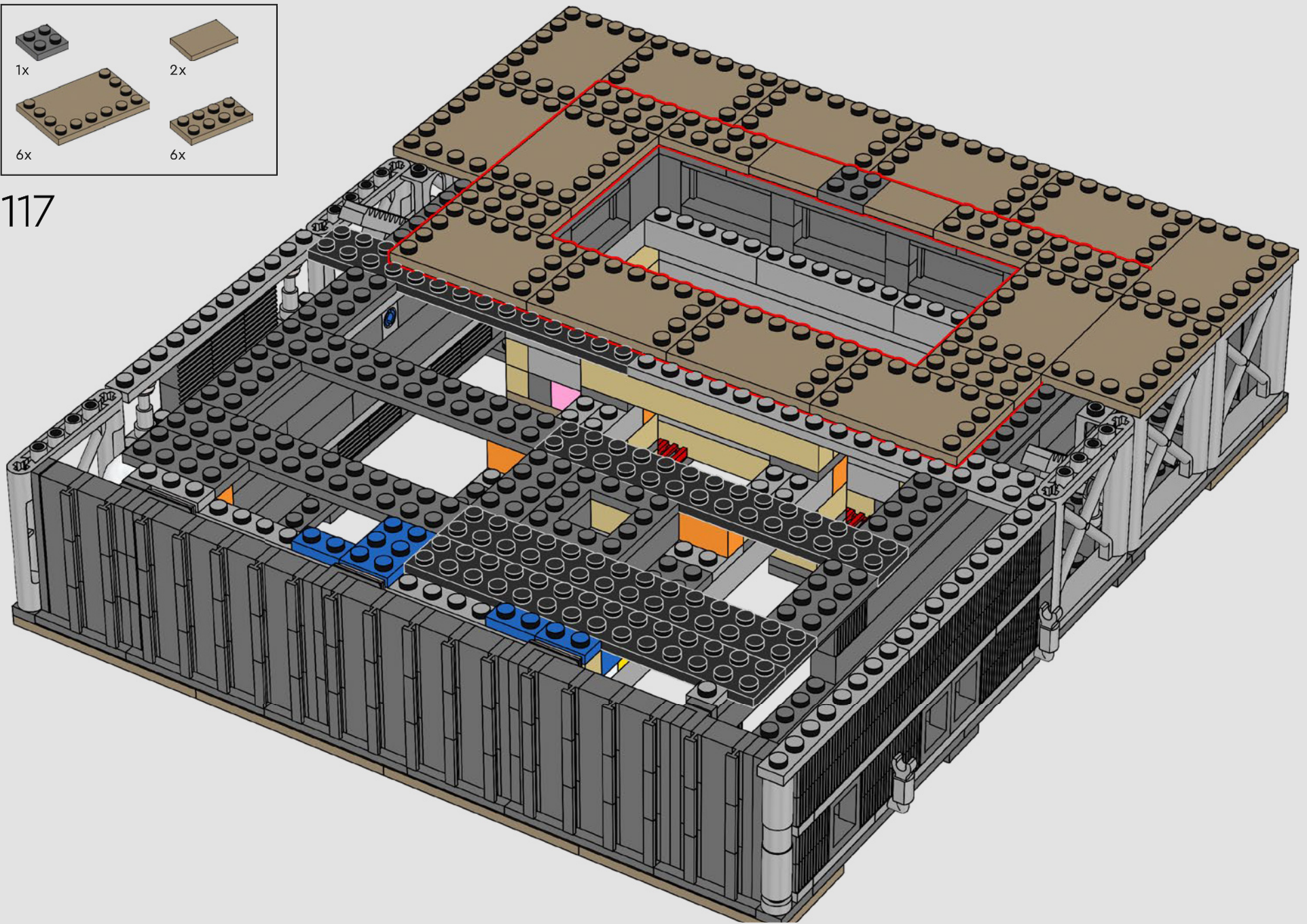

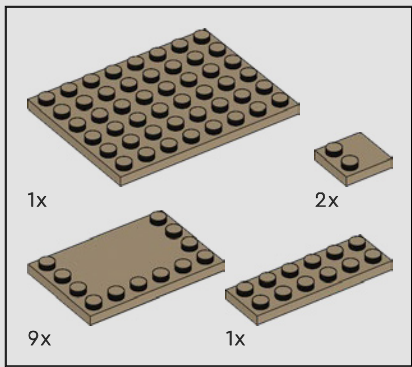

118

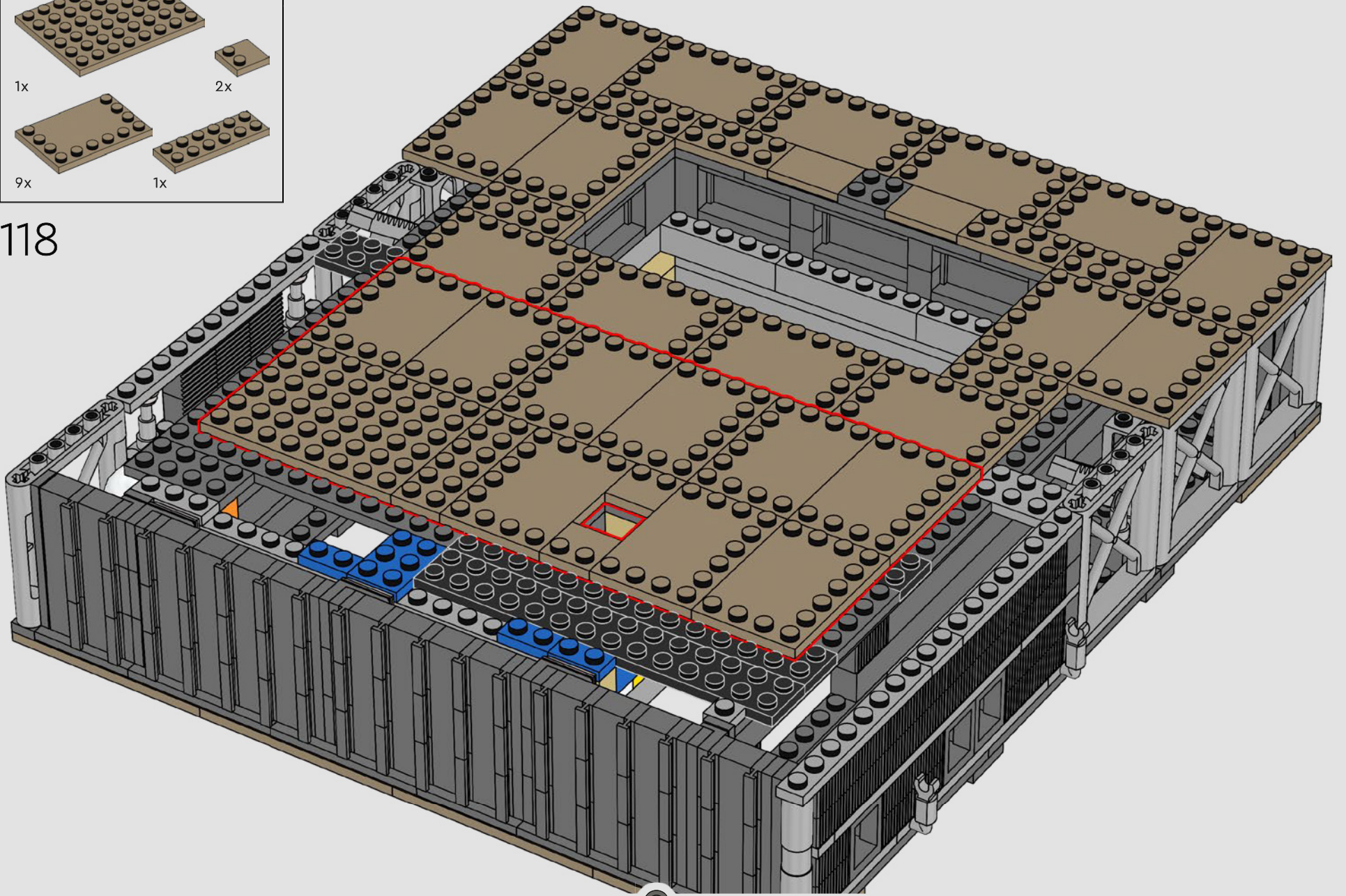

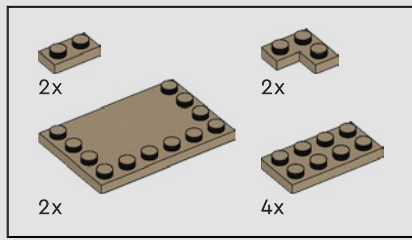

119

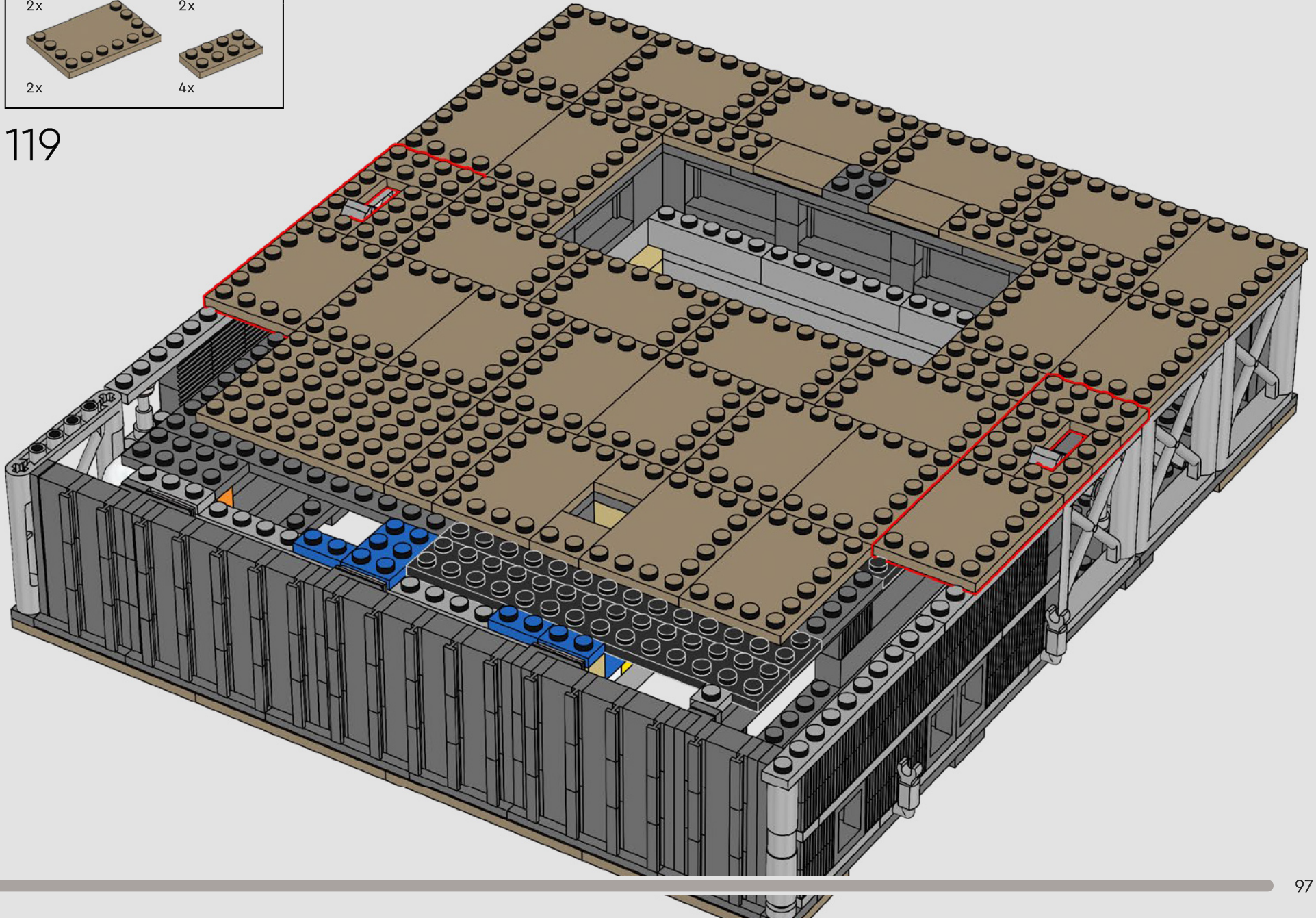

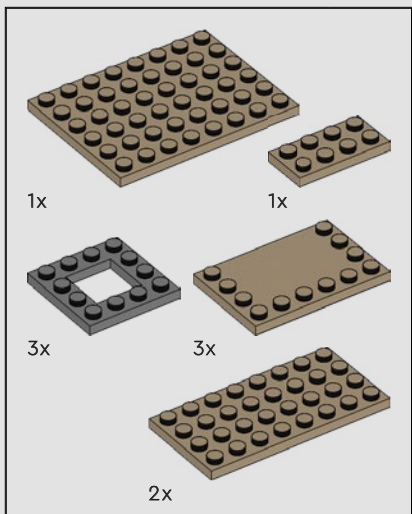

120

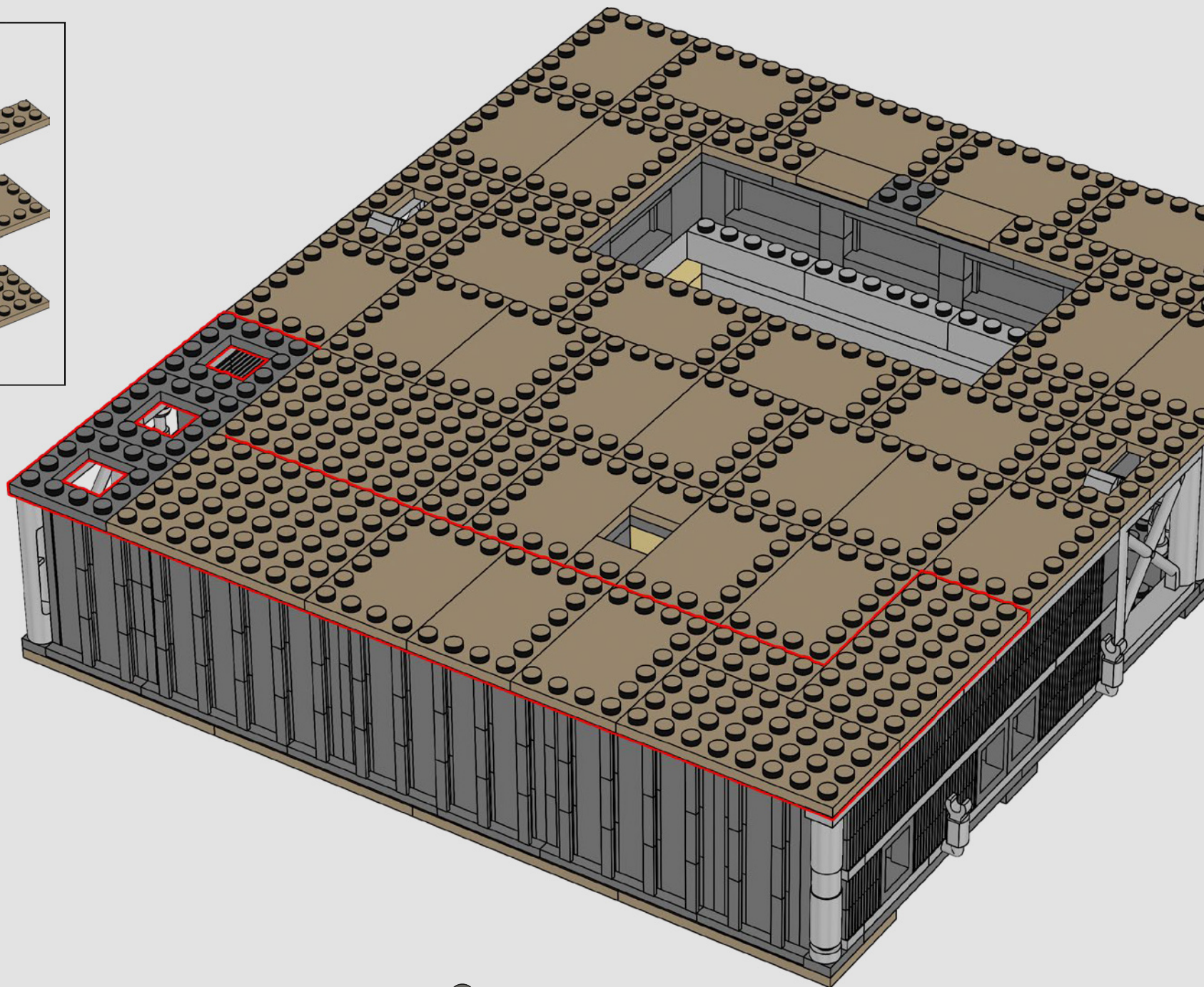

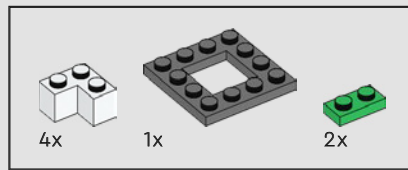

121

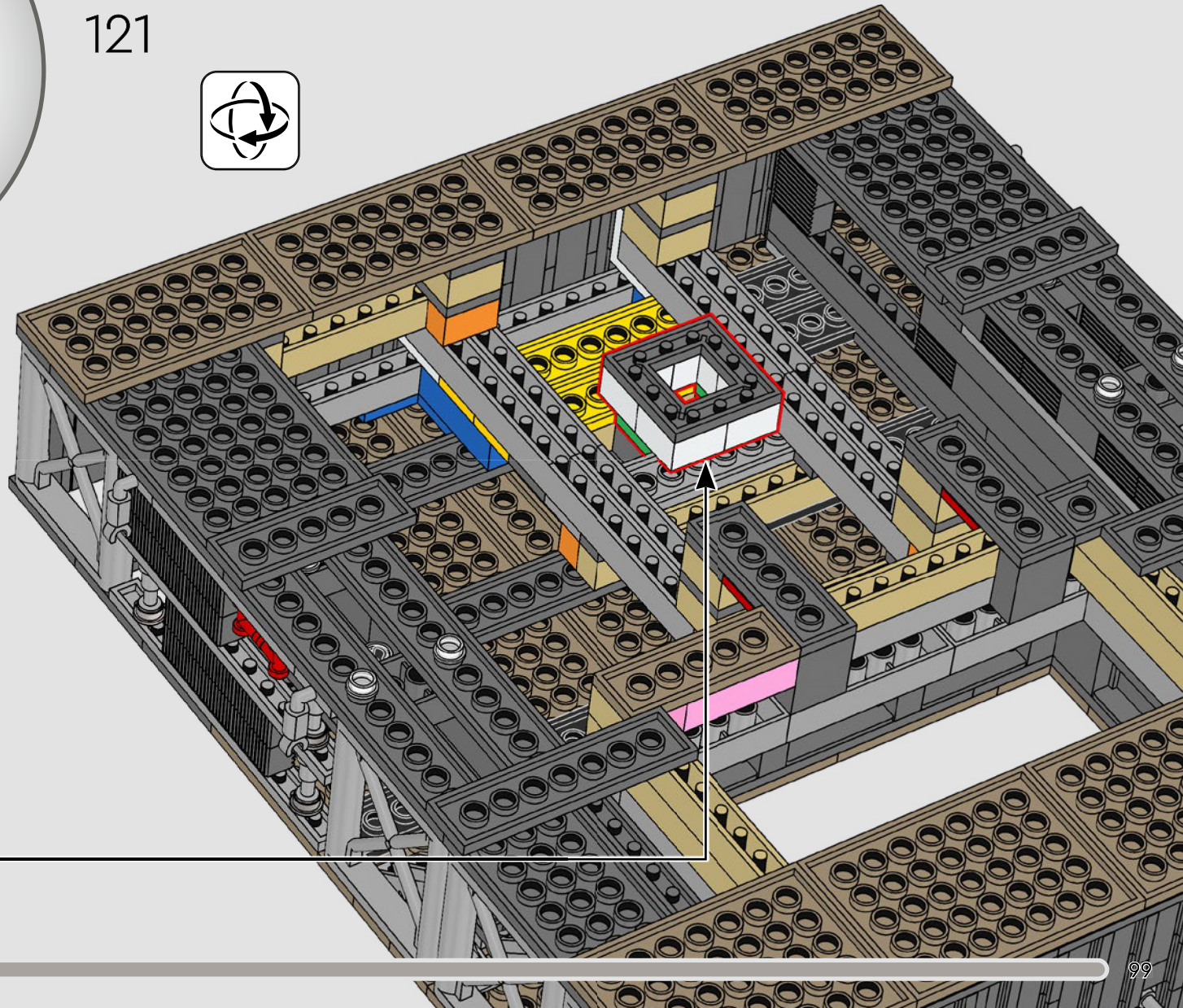
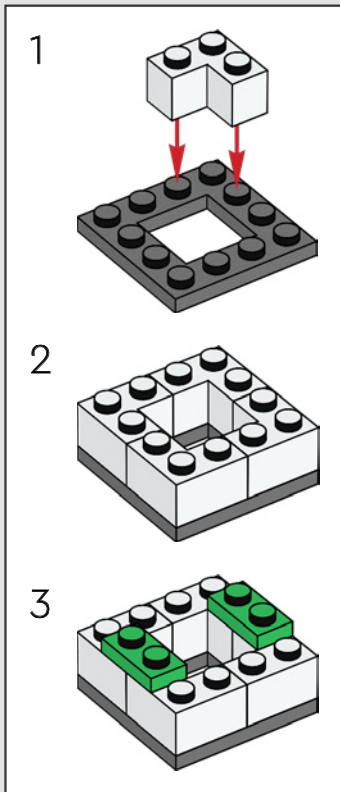
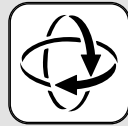



122

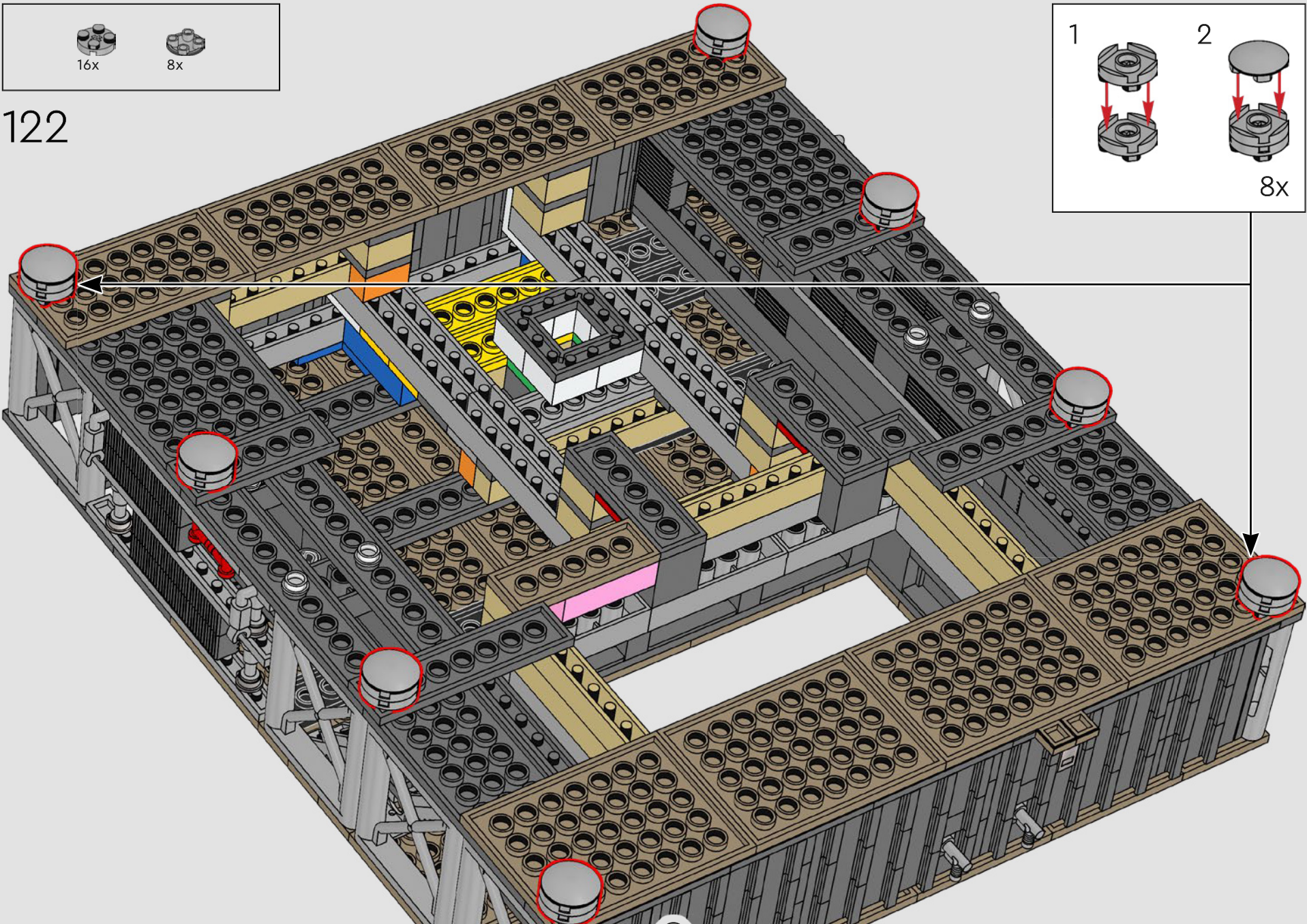
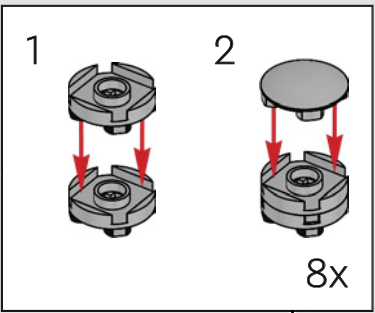

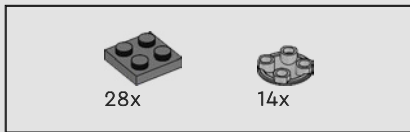

123

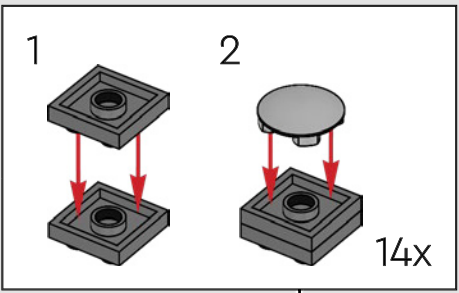
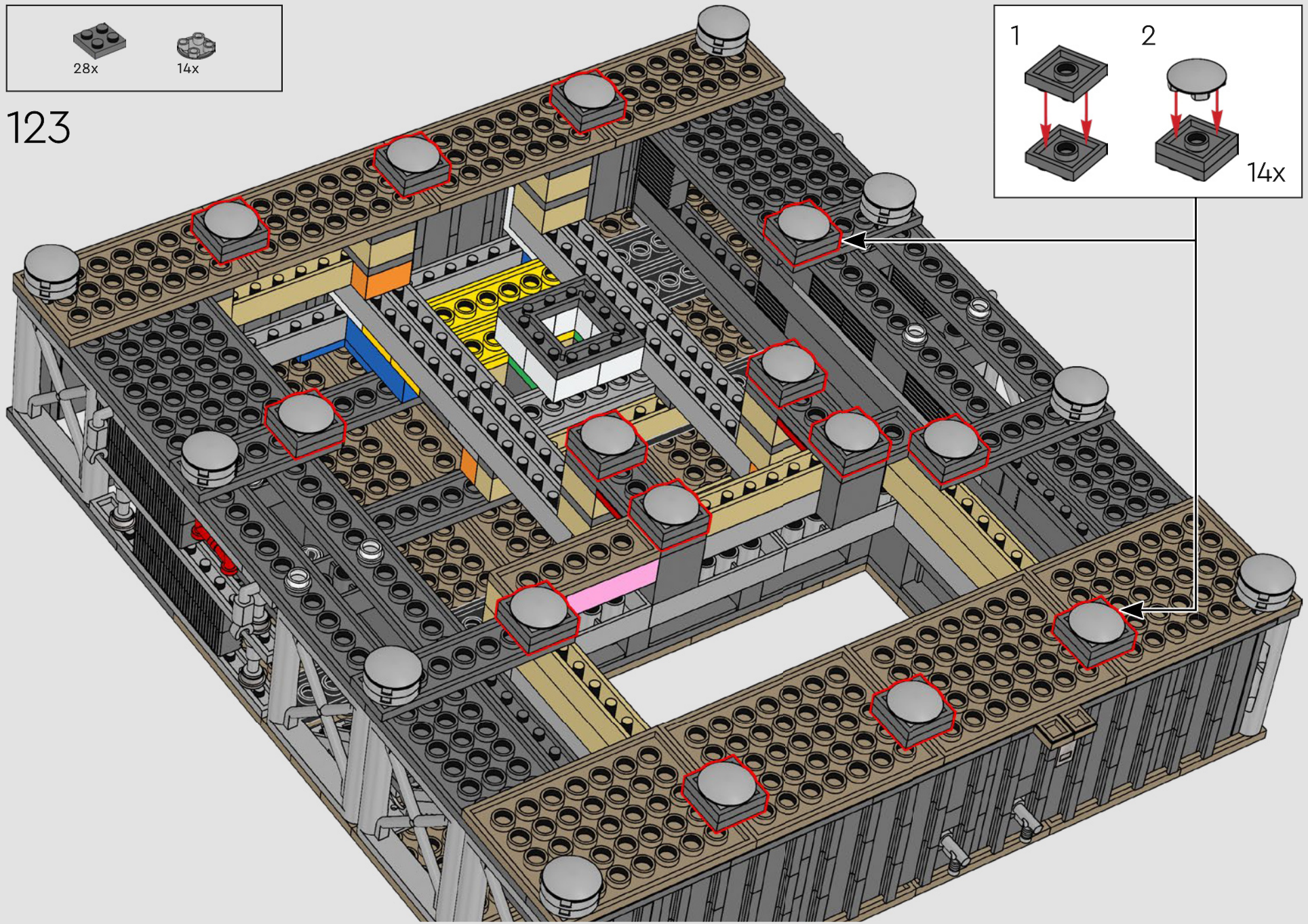

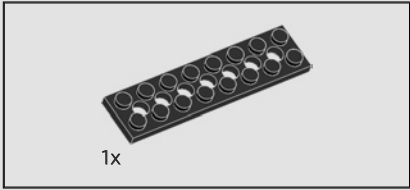
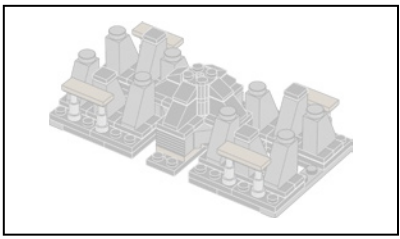

124

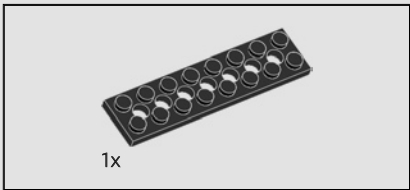

125

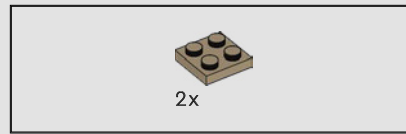
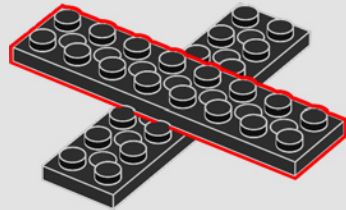
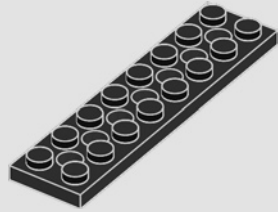

126

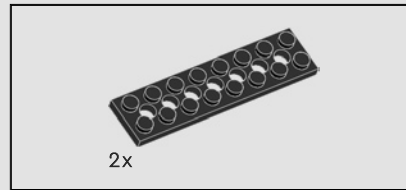
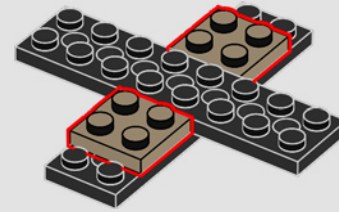

127

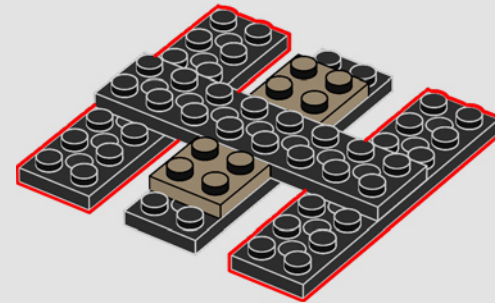

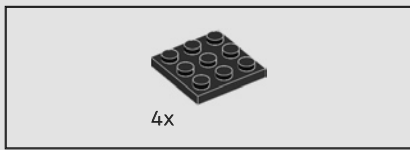

128

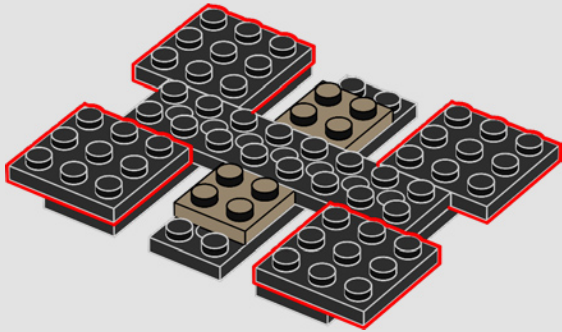

129

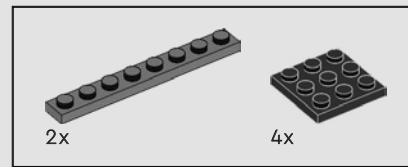
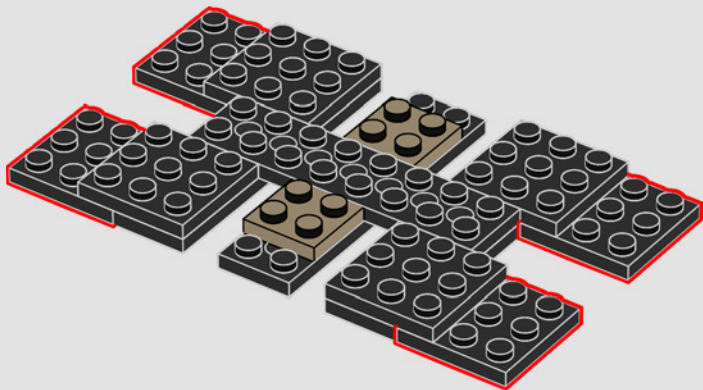

130

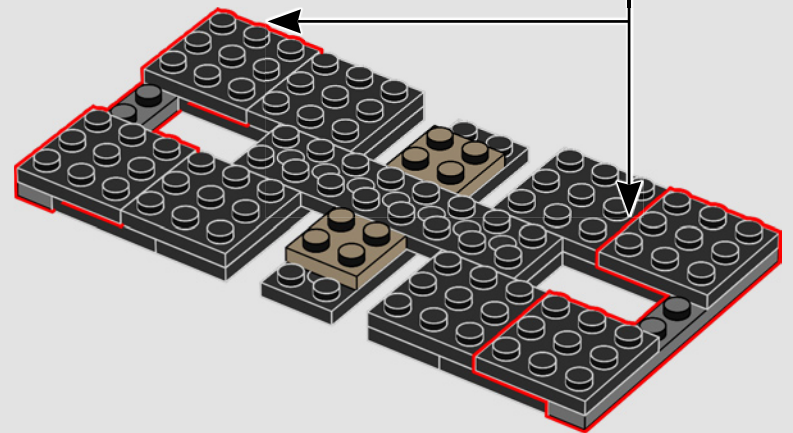
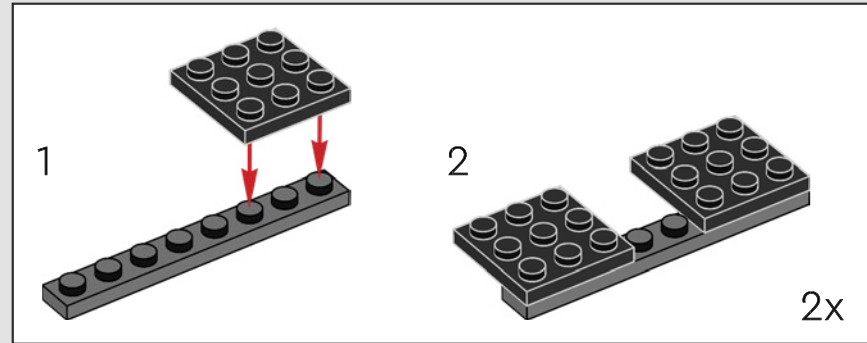



24x

131

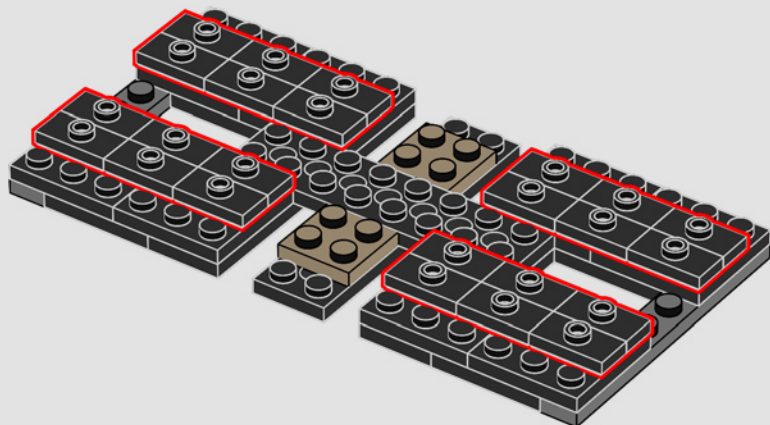

4x

132

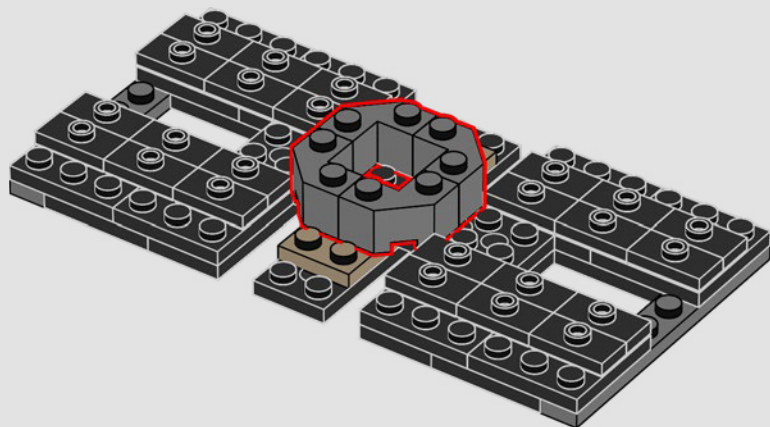

4x

133

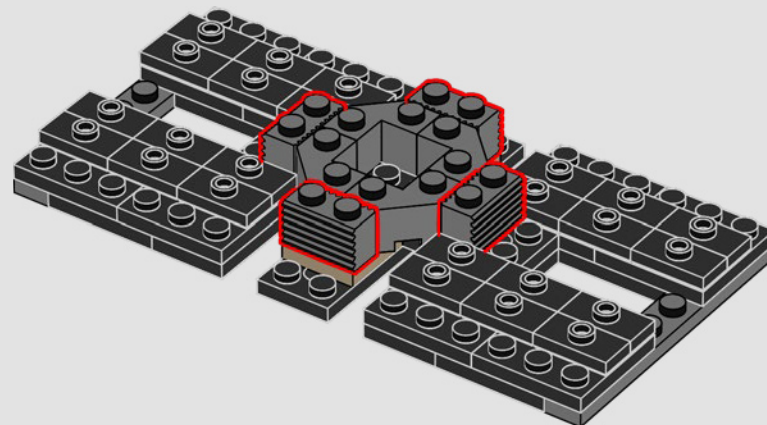

8x

134

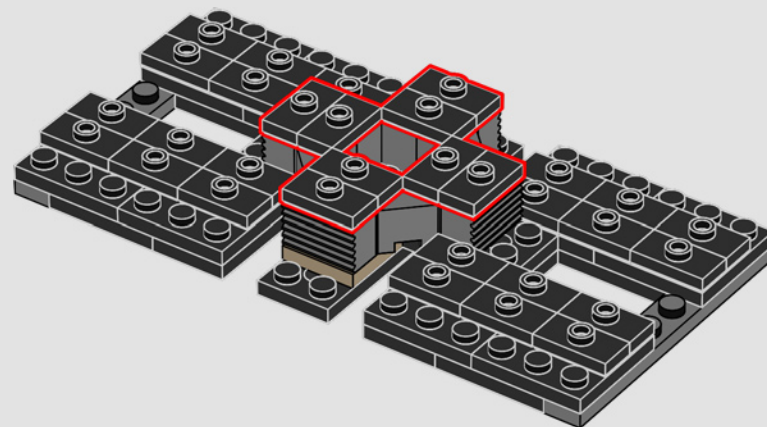



135

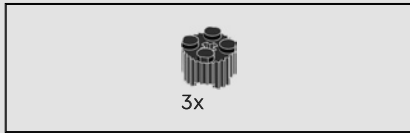
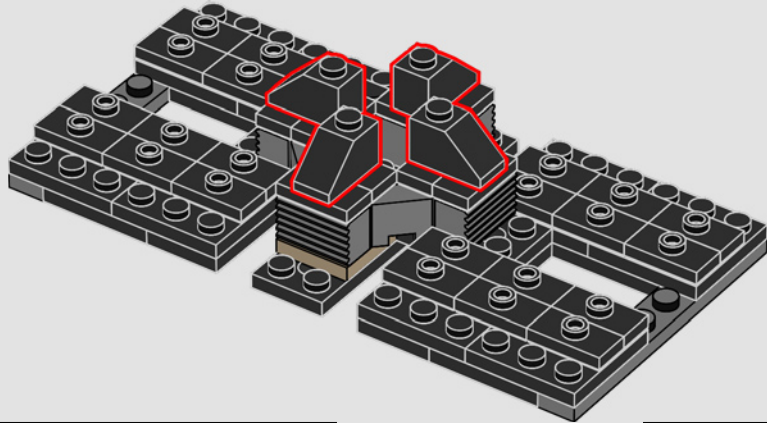

136

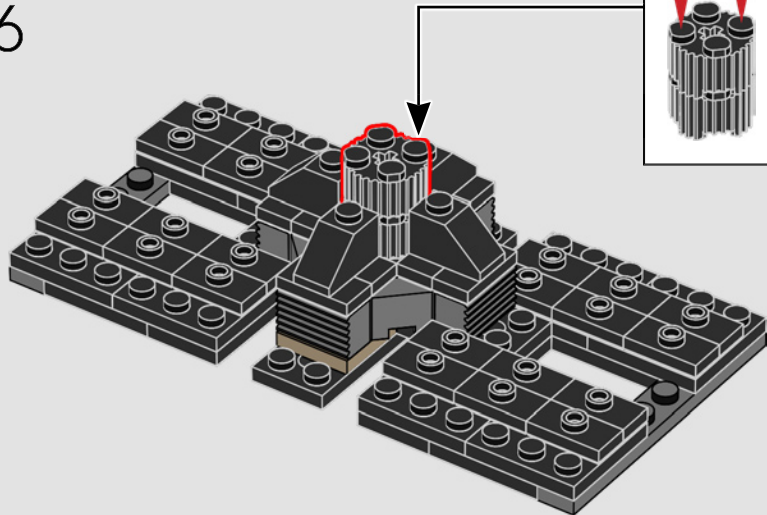

137

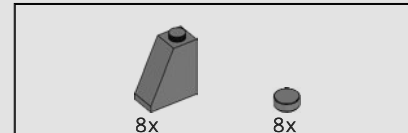
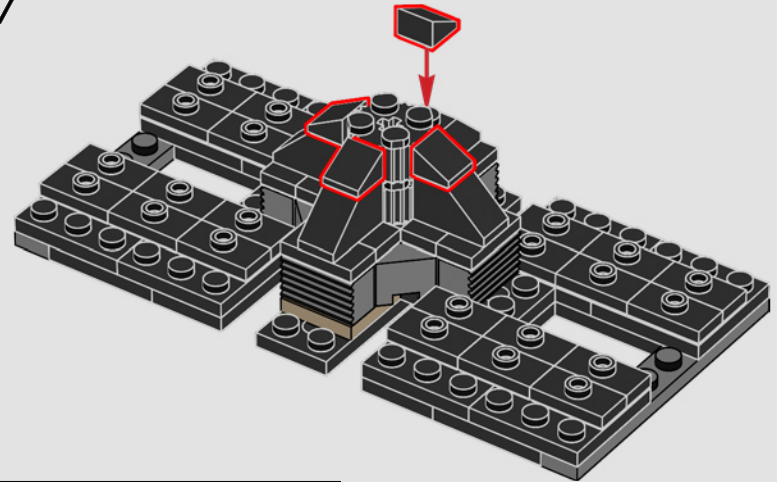

138

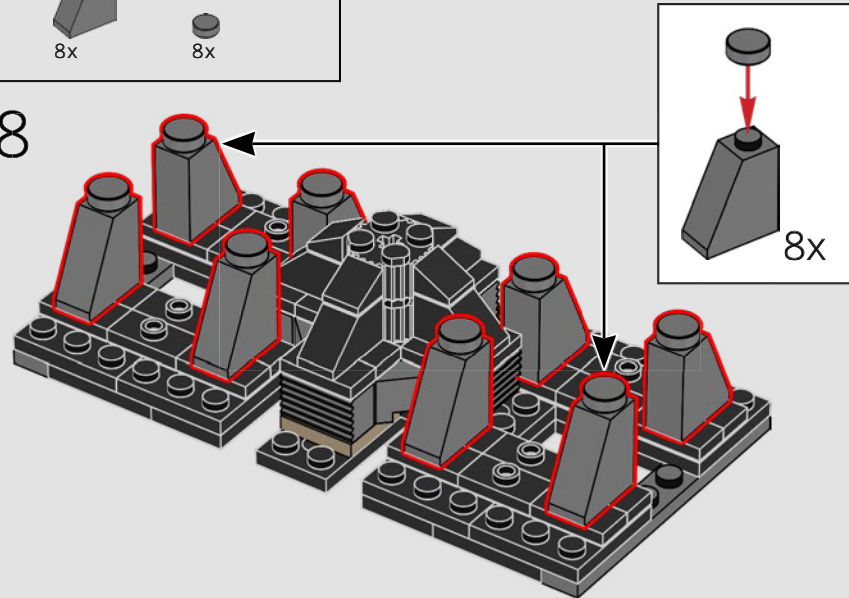

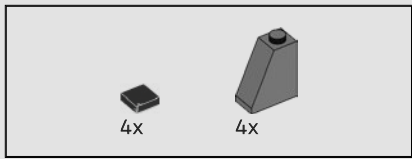

139

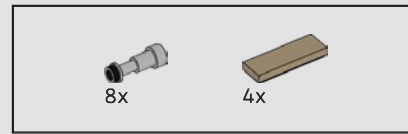
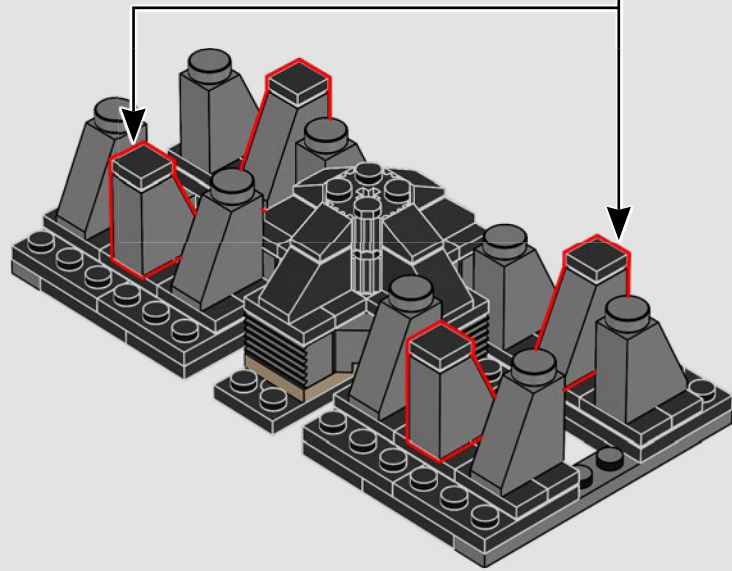
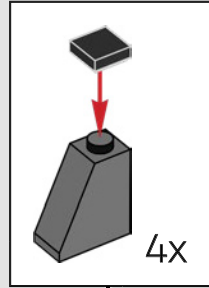

140

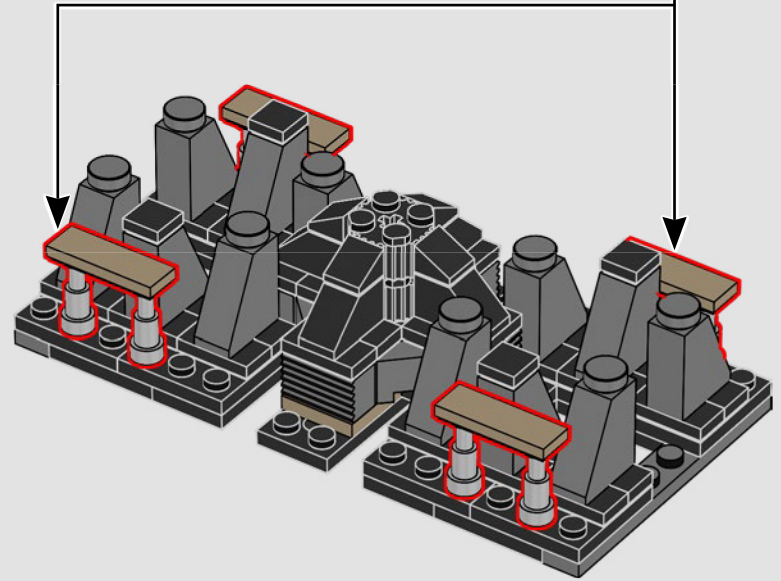
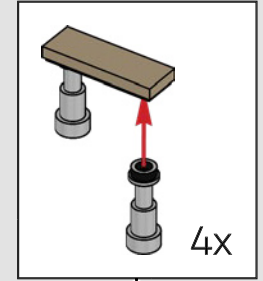

141

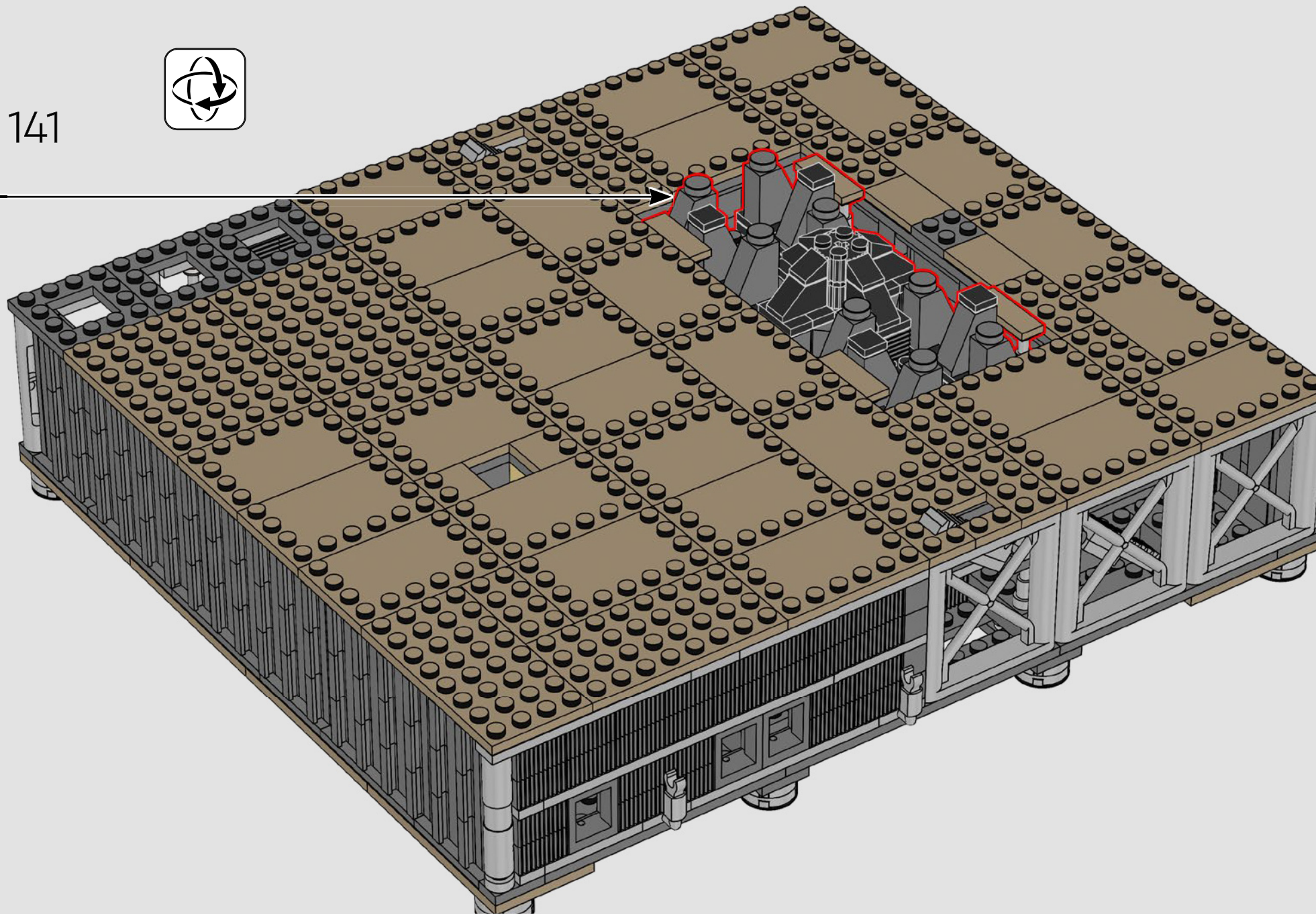

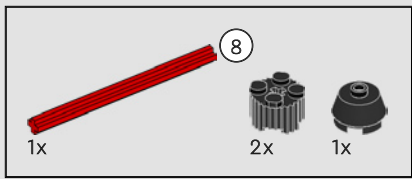

142

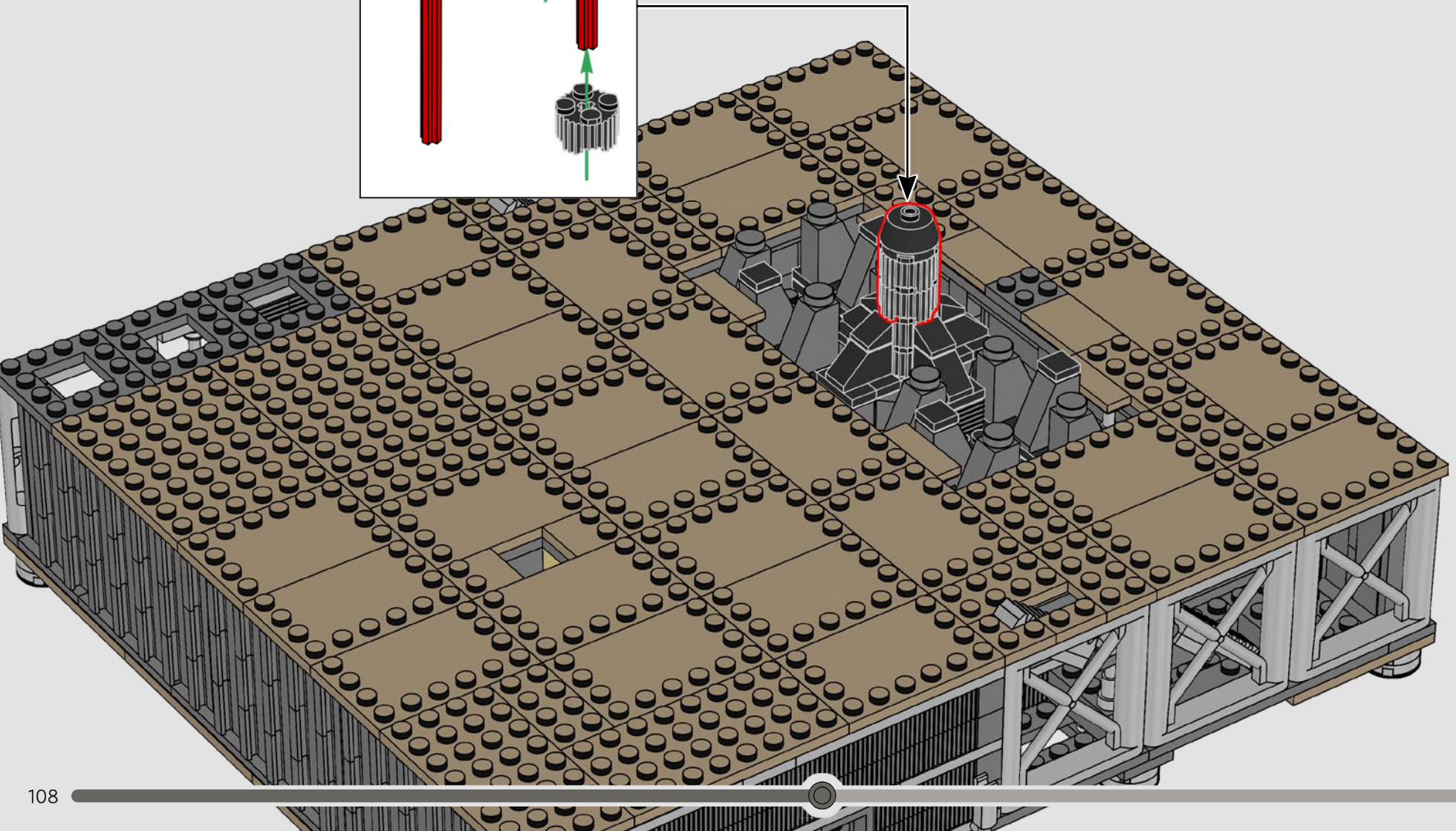
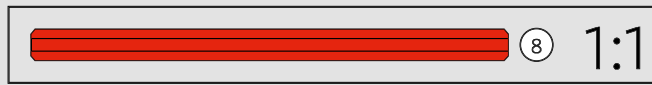
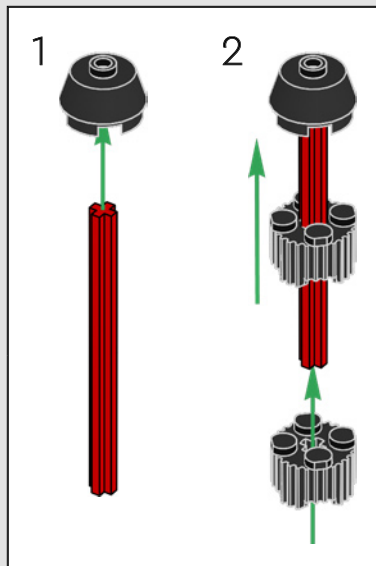

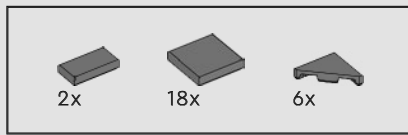

143

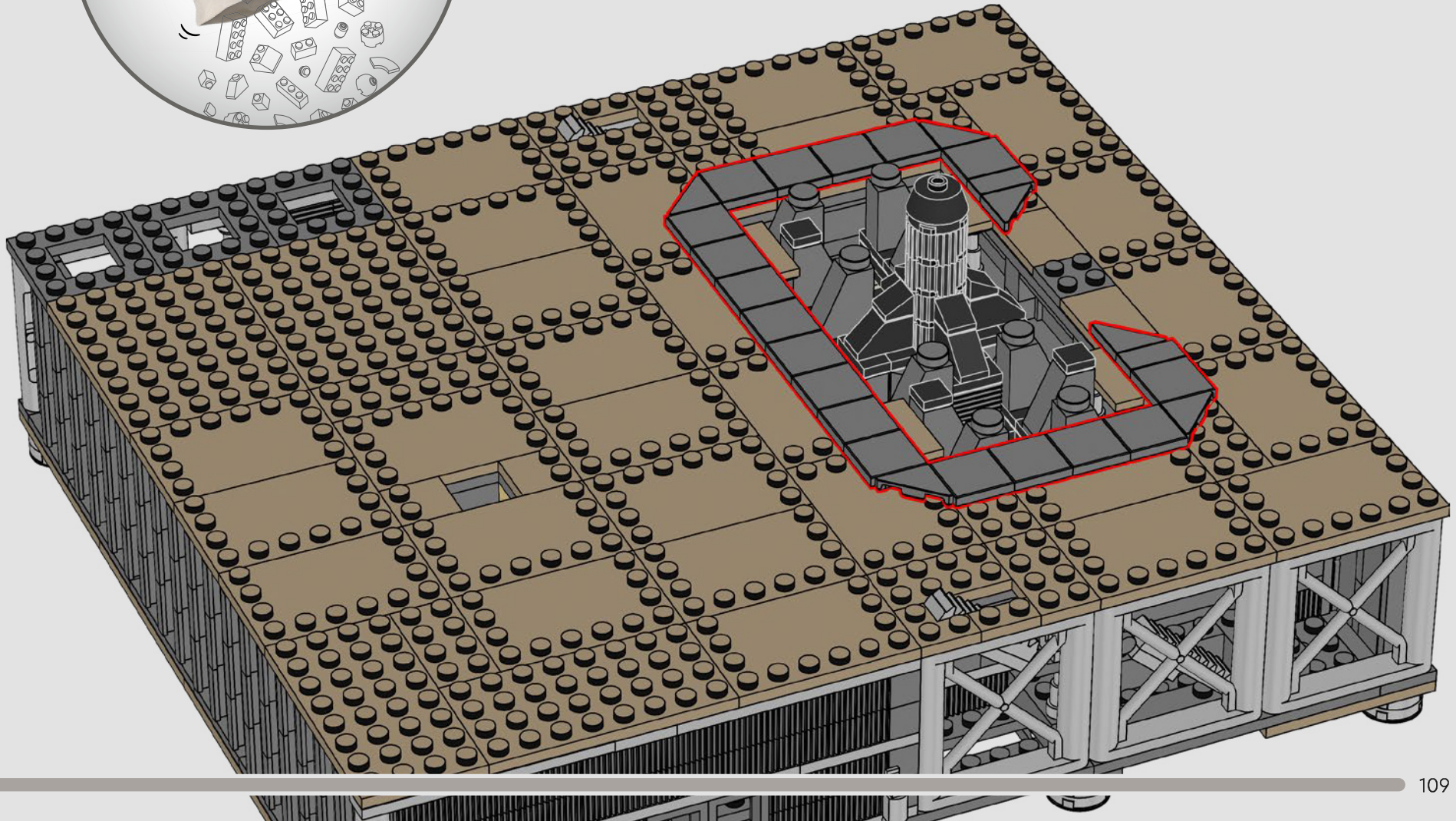

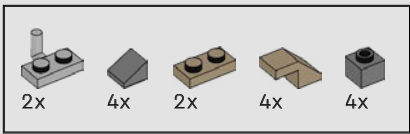

144

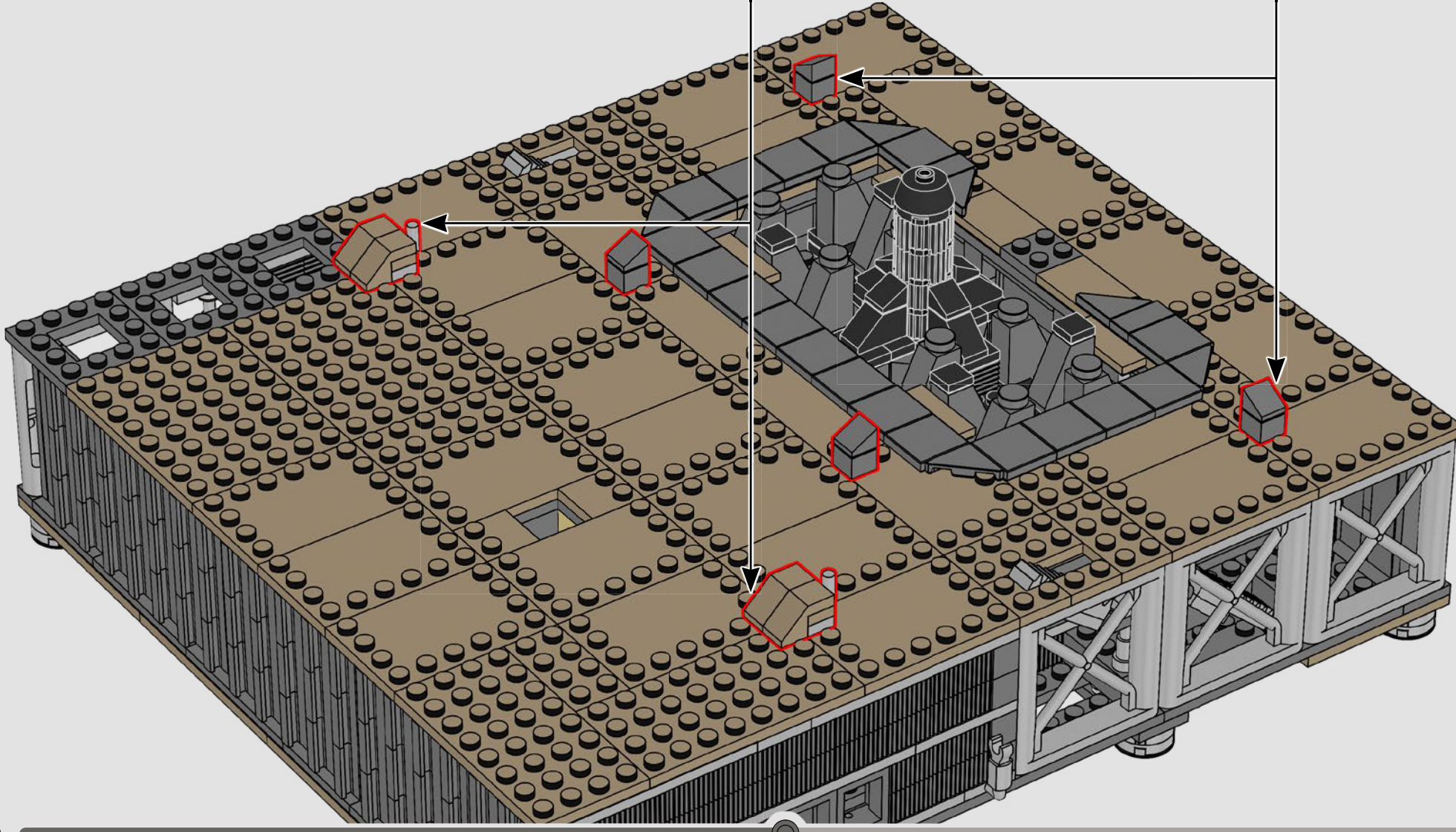
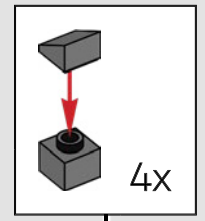
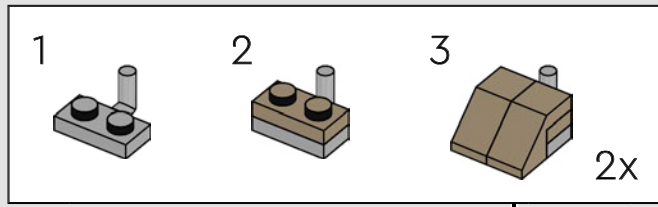

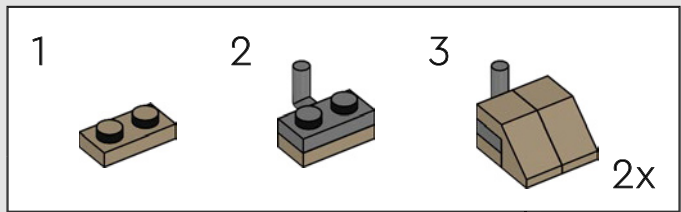
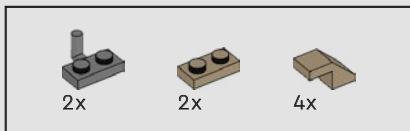

145

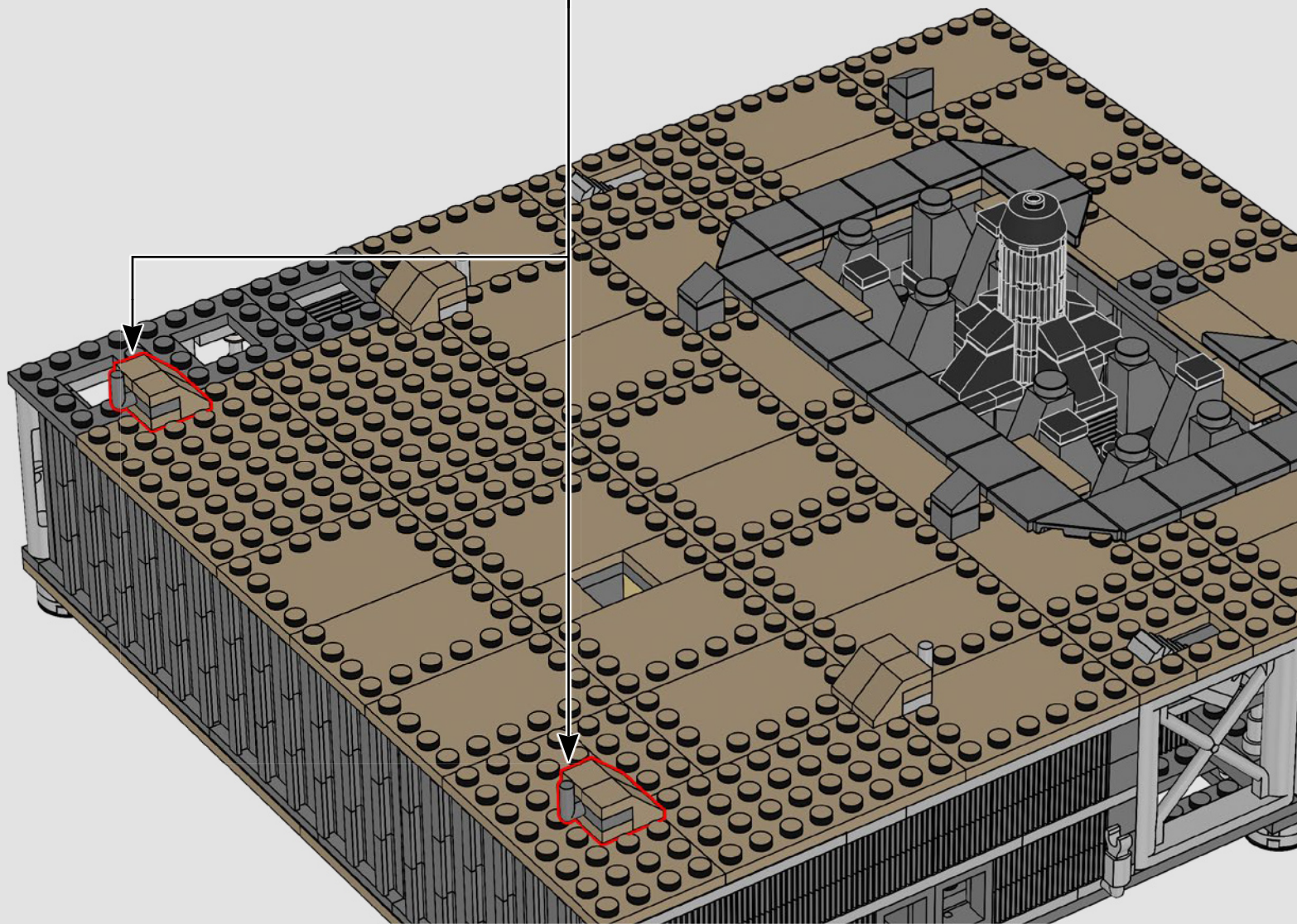



88x

146

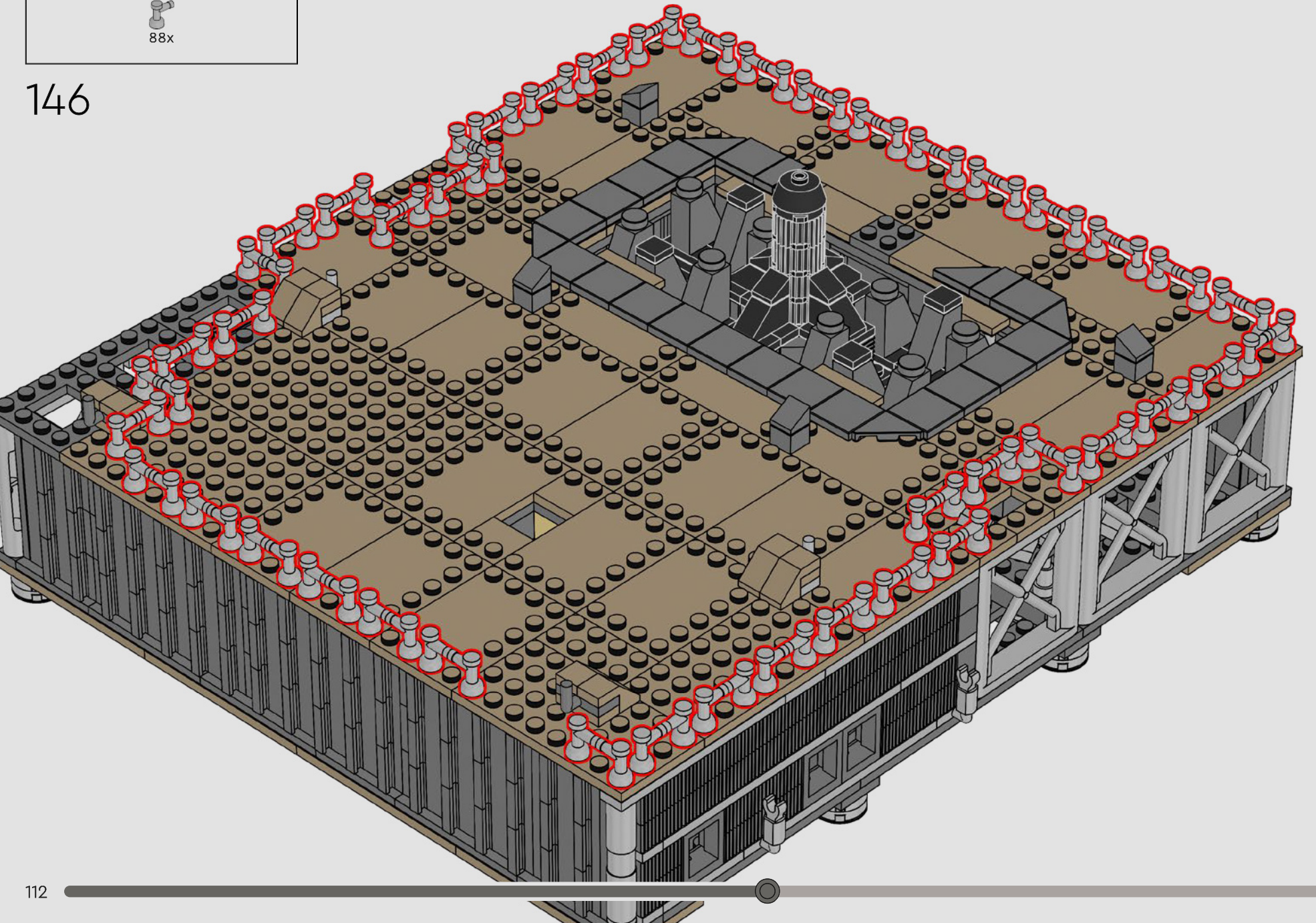

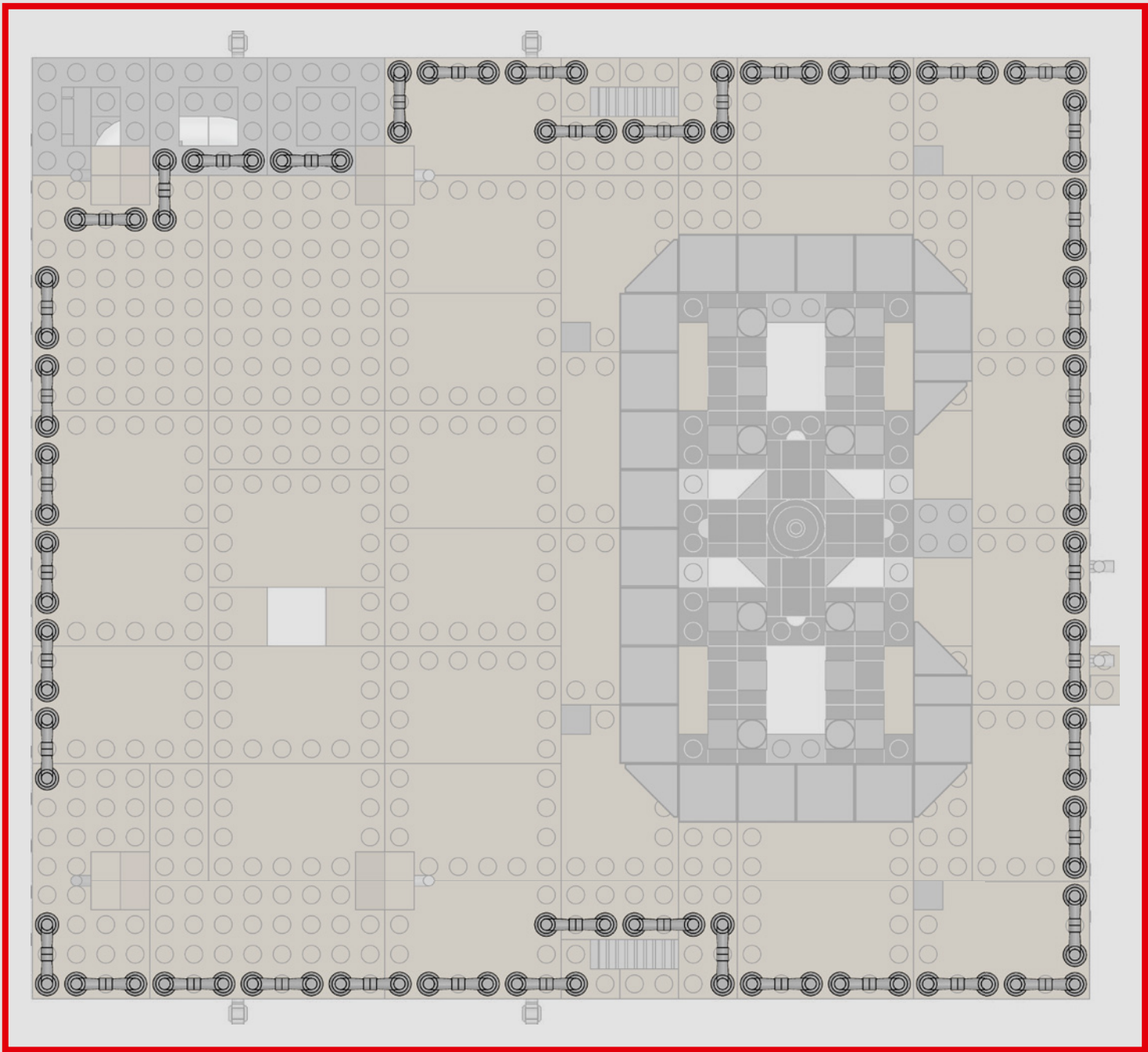

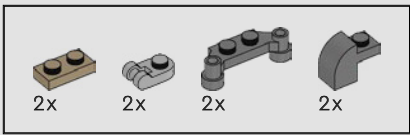

147

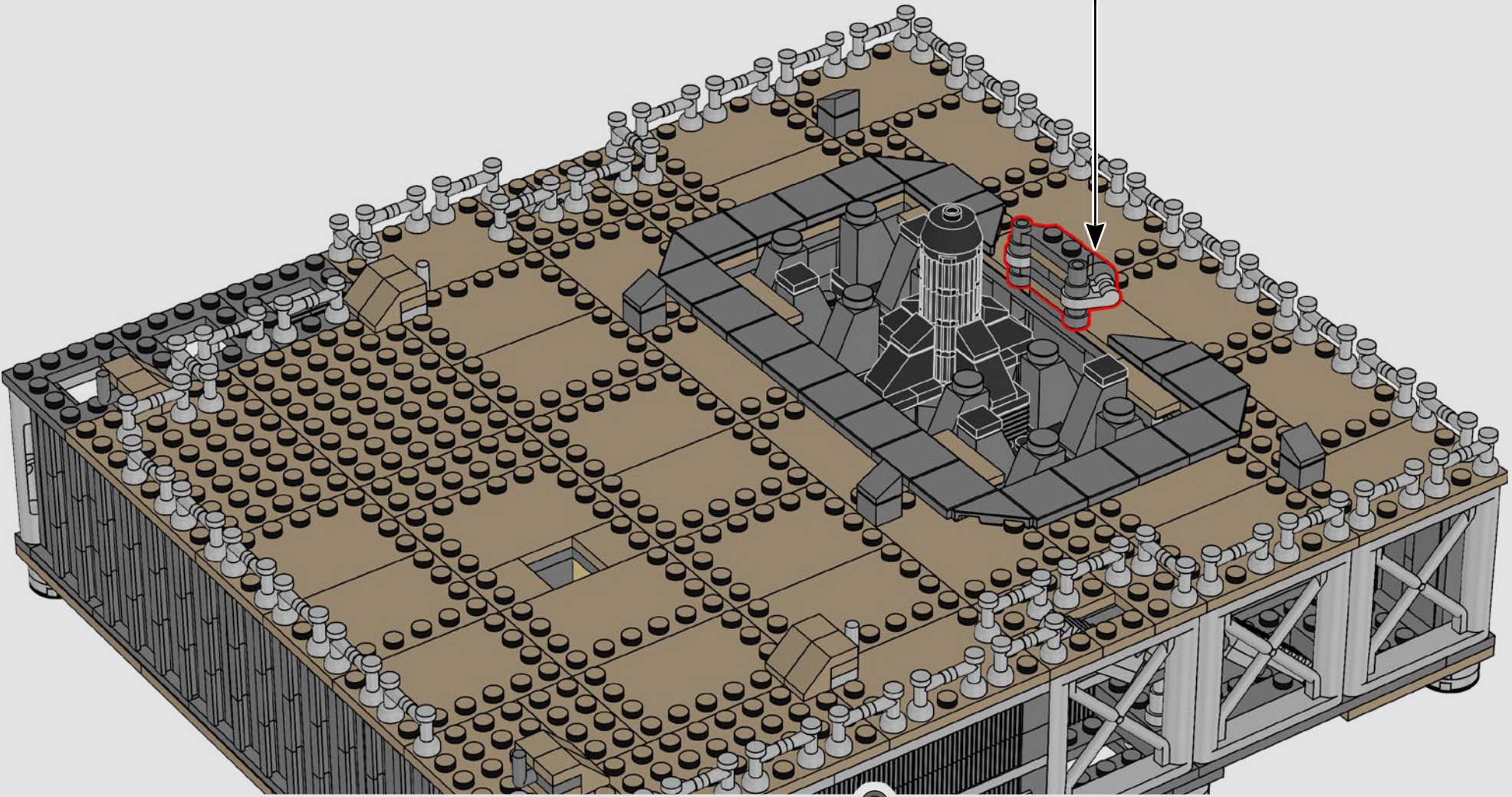
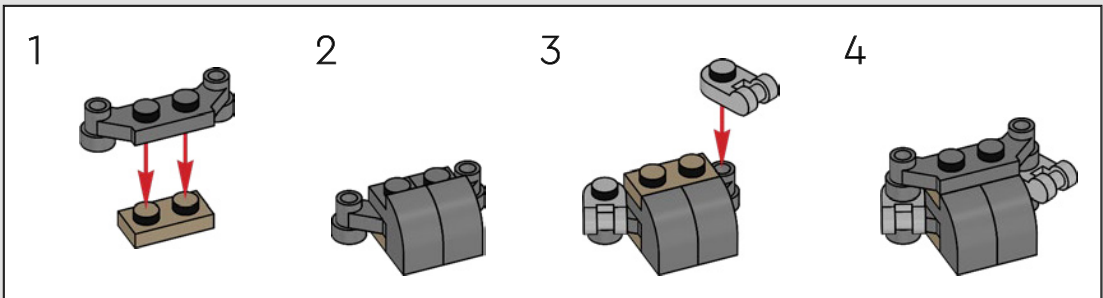

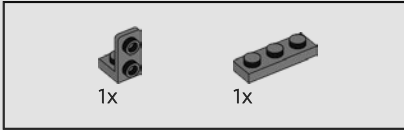
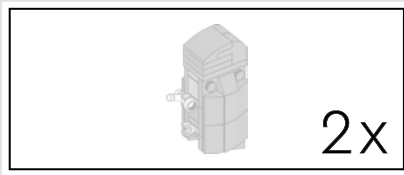

148

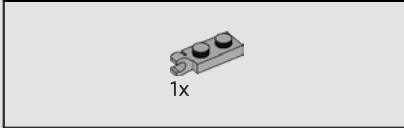
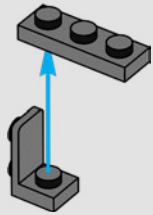

149

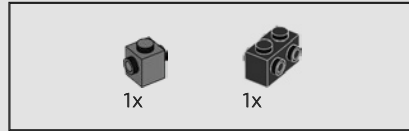
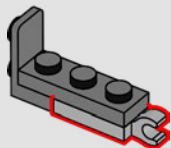

150

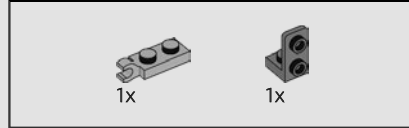
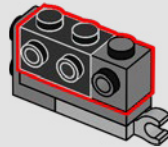

151

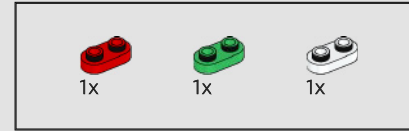
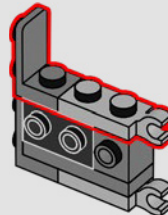

152

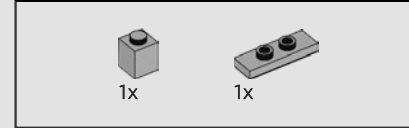
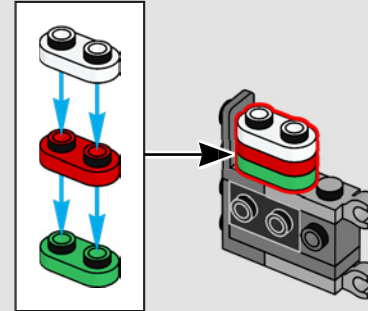

153

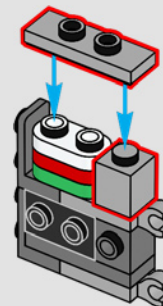

154

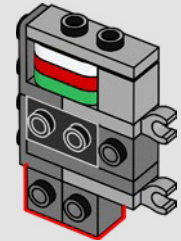

Eine LEGO® Rakete muss natürlich nach LEGO Art angetrieben werden. Die aufeinandergesteckten runden 1x2 Platten in der „Tanksäule“ vor der Rakete blicken auf eine lange LEGO Geschichte zurück!

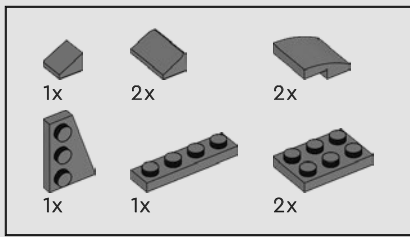

155

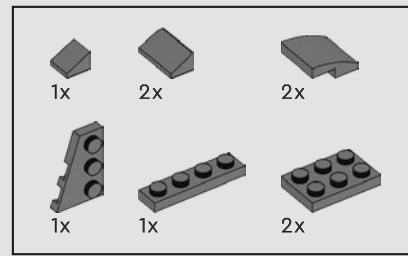
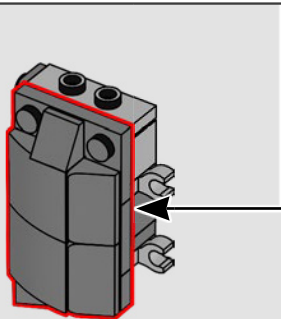
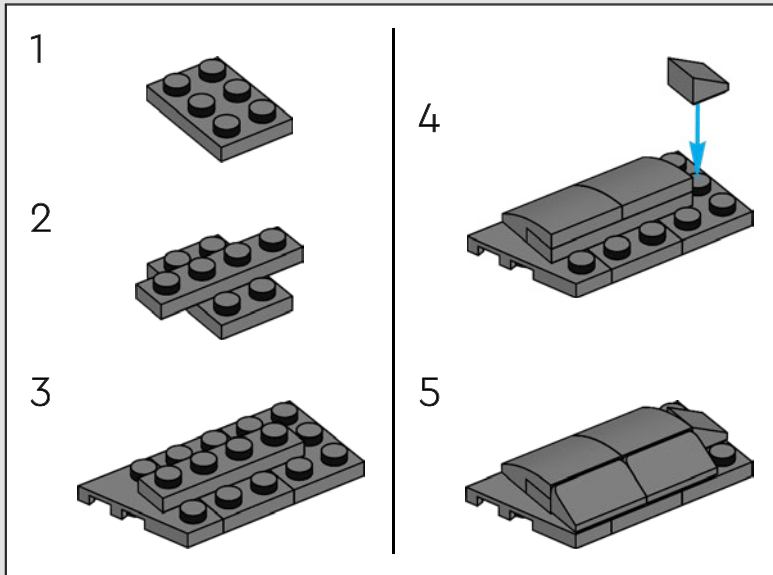

156

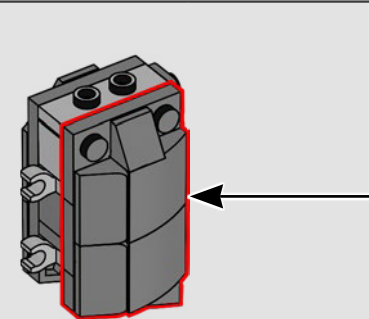
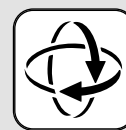
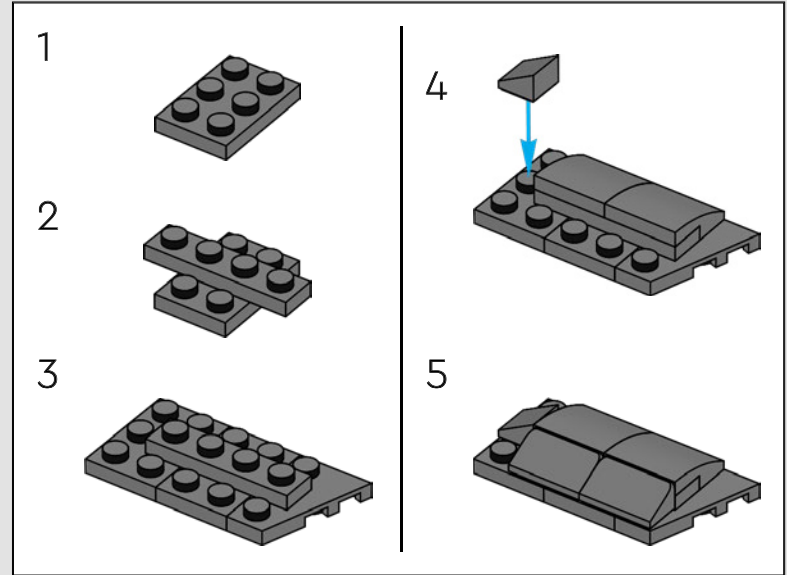

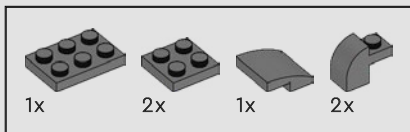

157

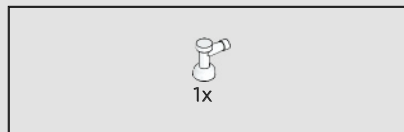
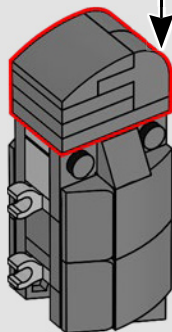
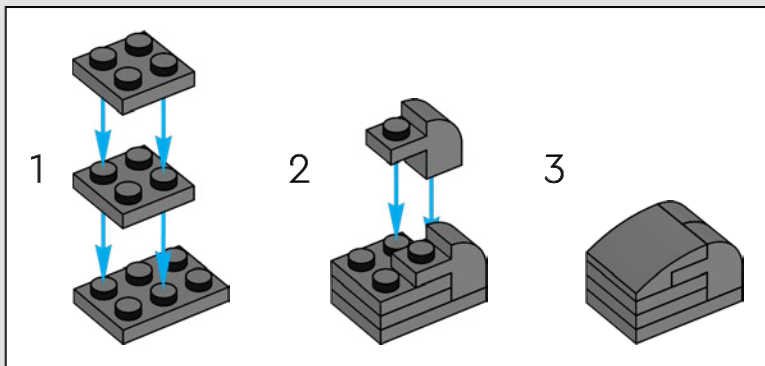

158

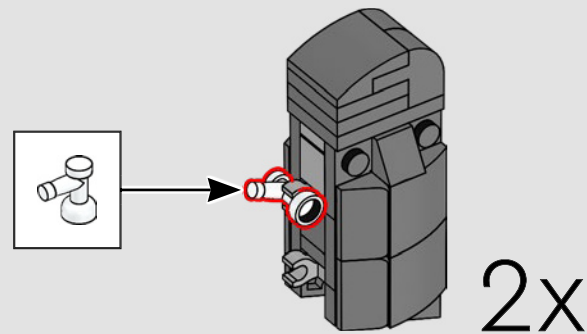

Das SLS nutzt größere Feststoffbooster als die NASA
Spaceshuttles. Flüssiger Wasserstoff und flüssiger
Sauerstoff werden den RS-25-Triebwerken zugeführt,
die mit einem höheren Schubniveau arbeiten und von
neuen Reglern gesteuert werden.

159

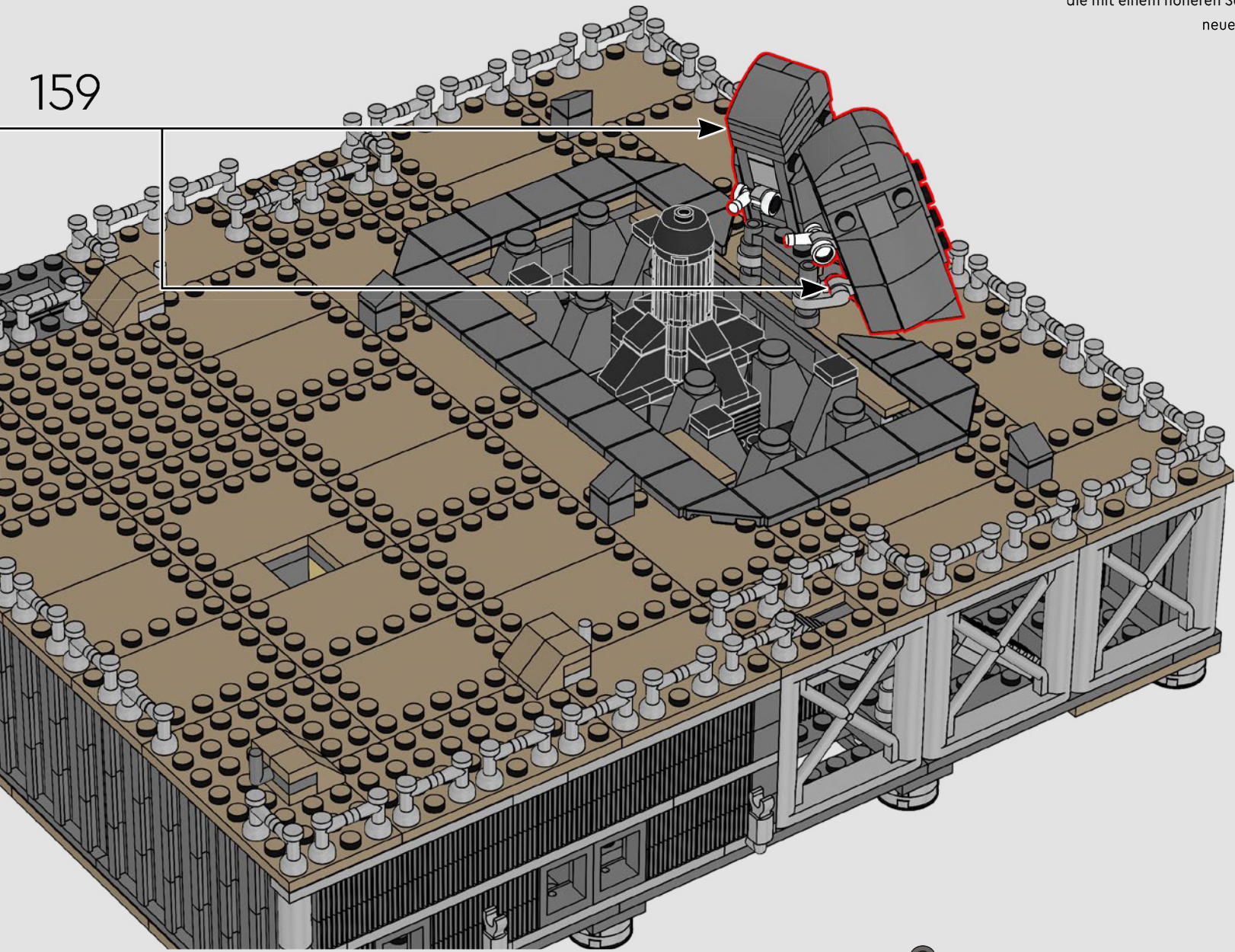

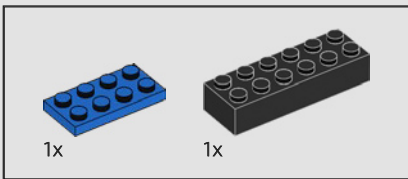
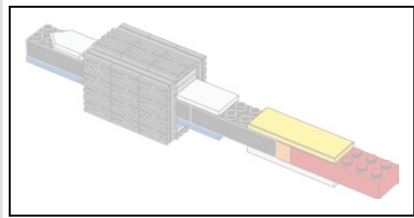

160

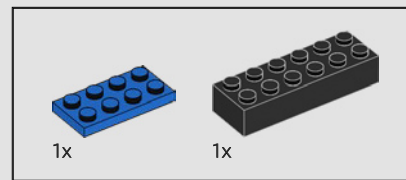
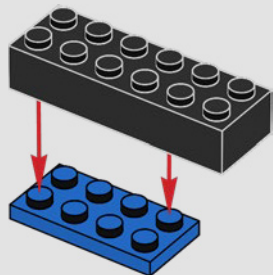

161

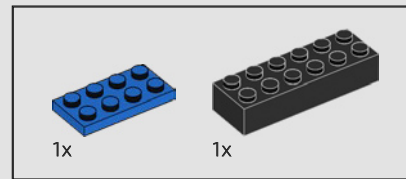
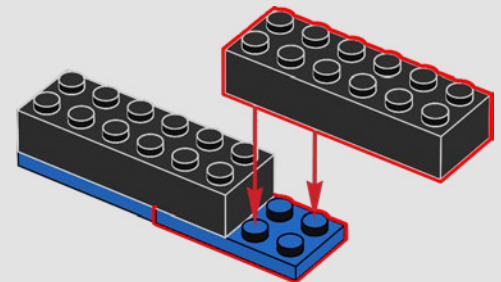

162

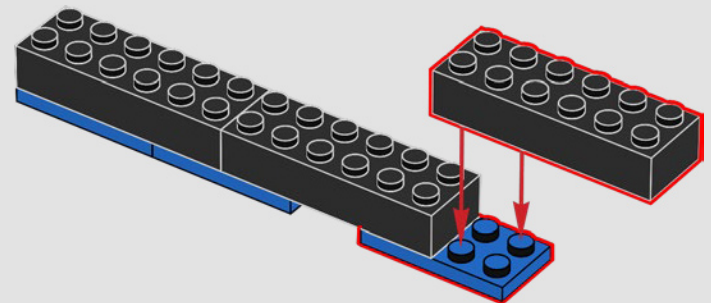

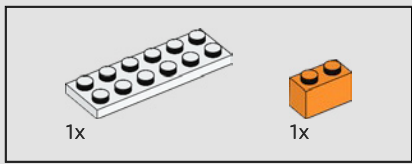

163

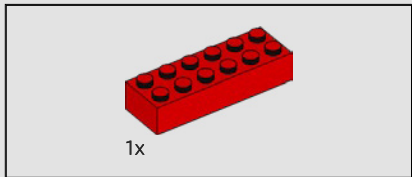
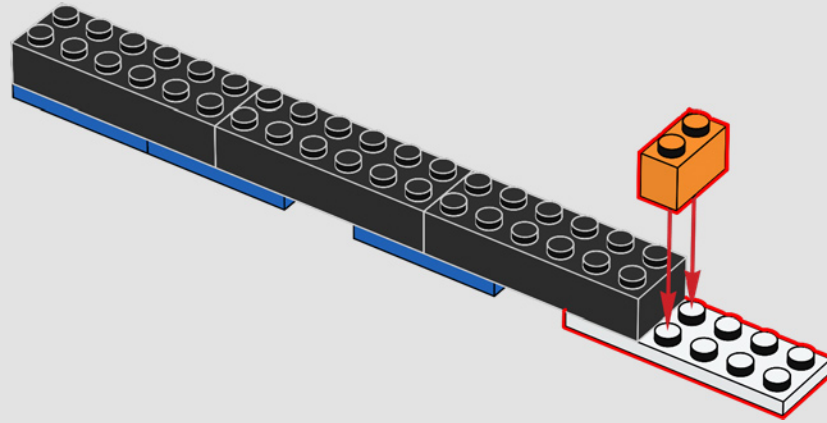

164

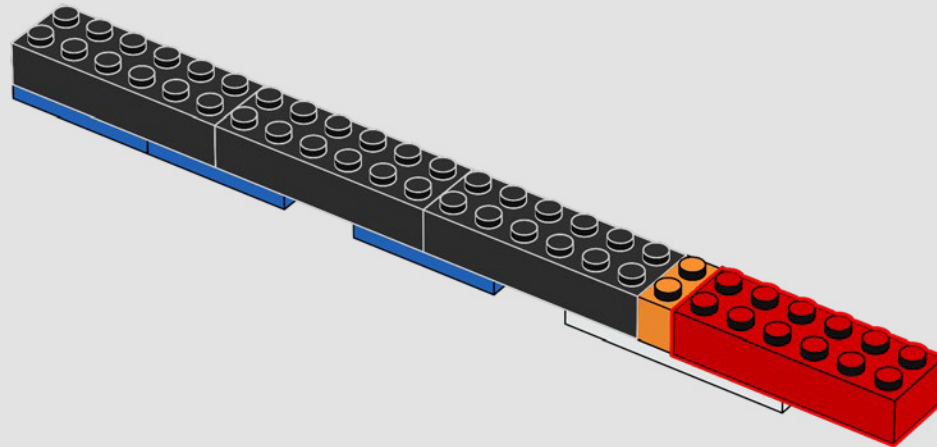

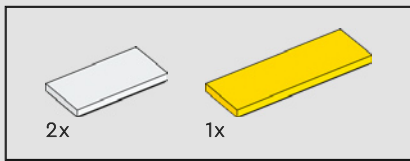

165

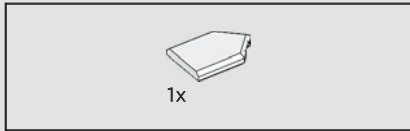
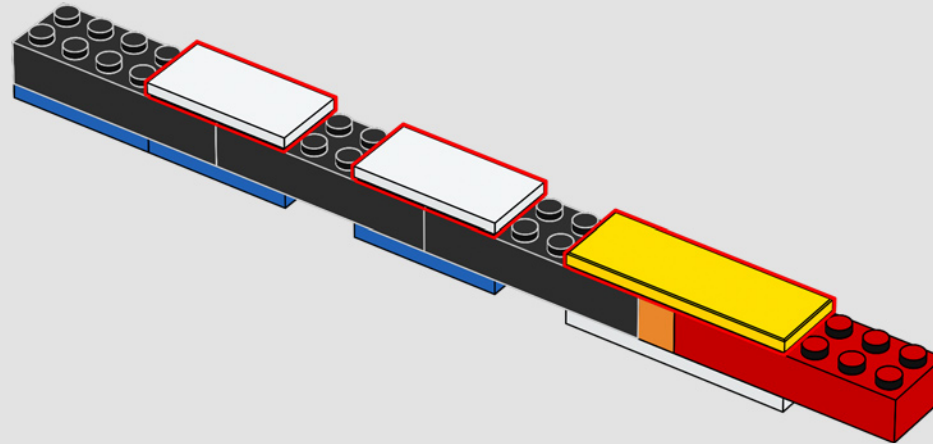

166

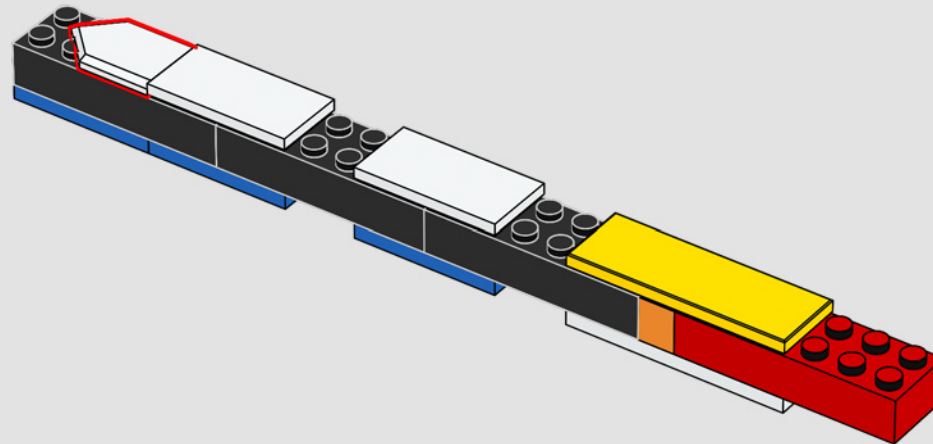

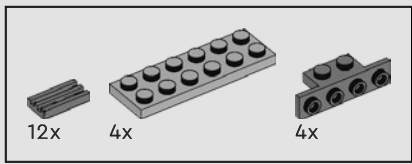

167

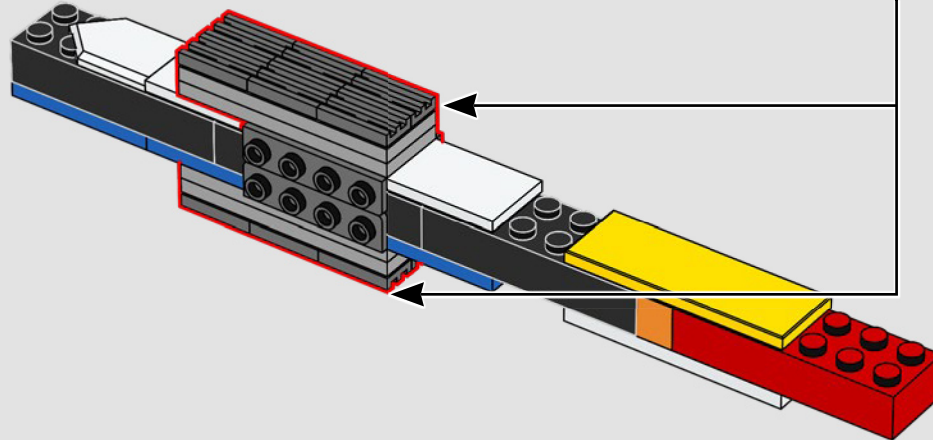
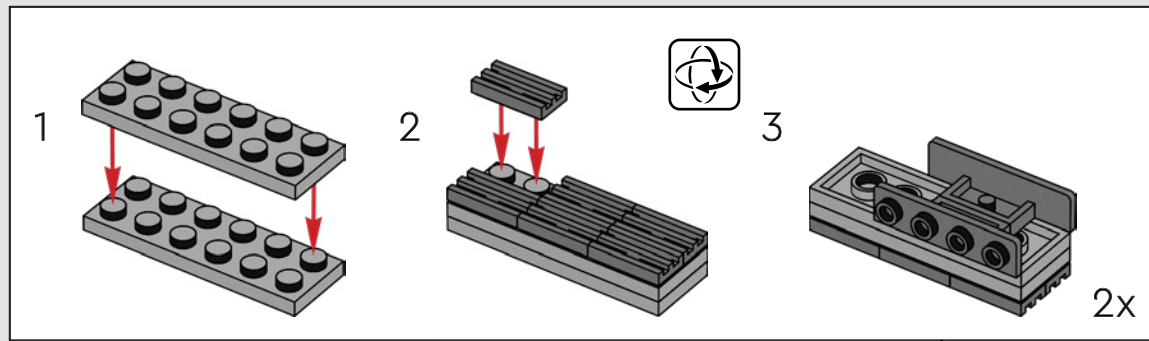

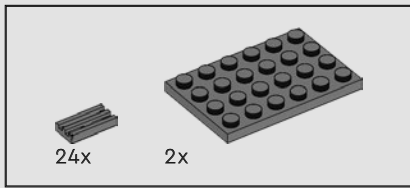

168

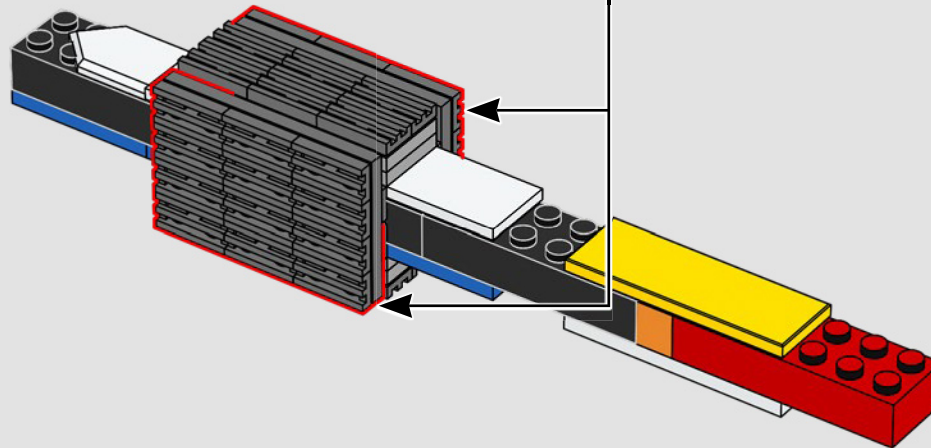
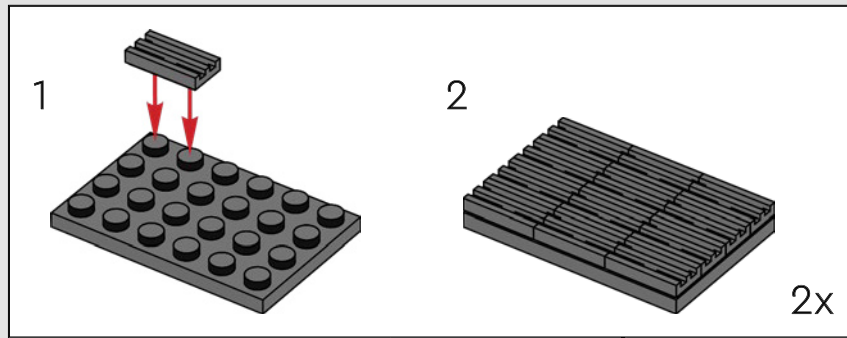

169

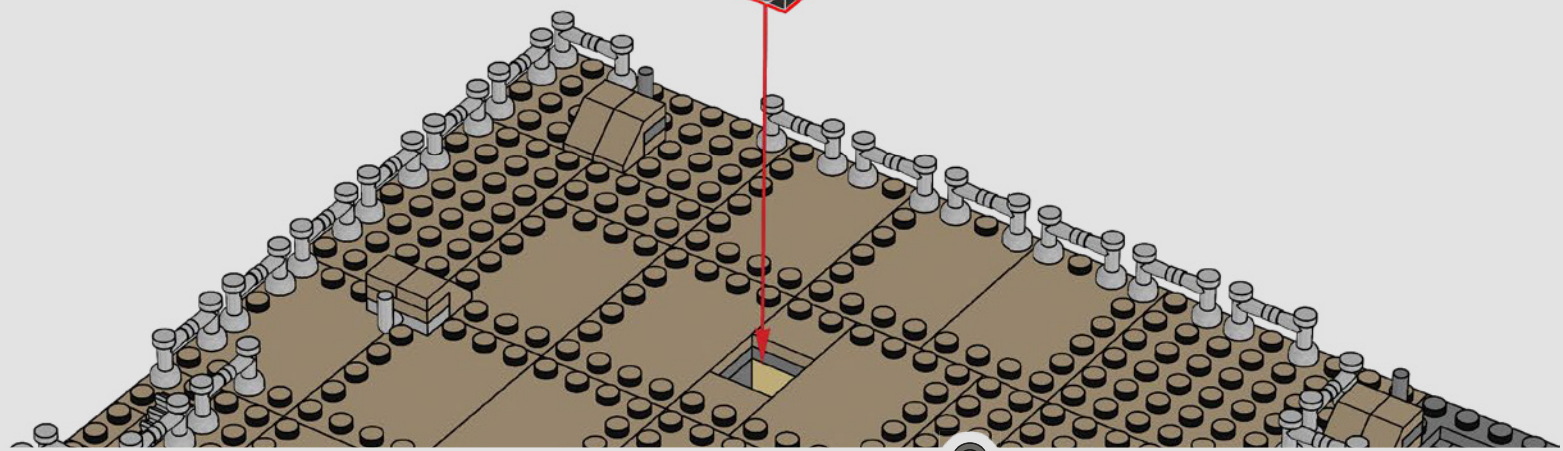
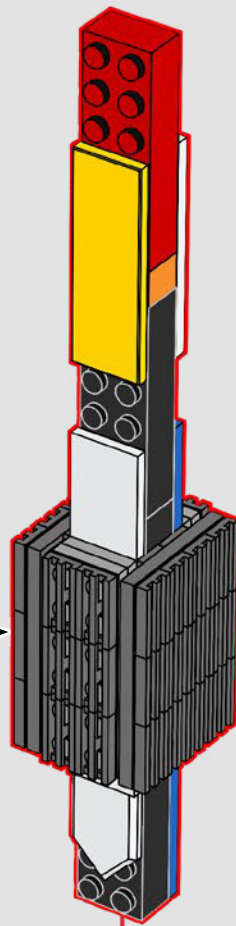

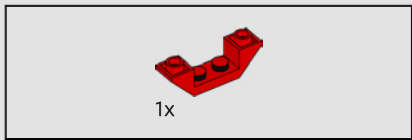

170

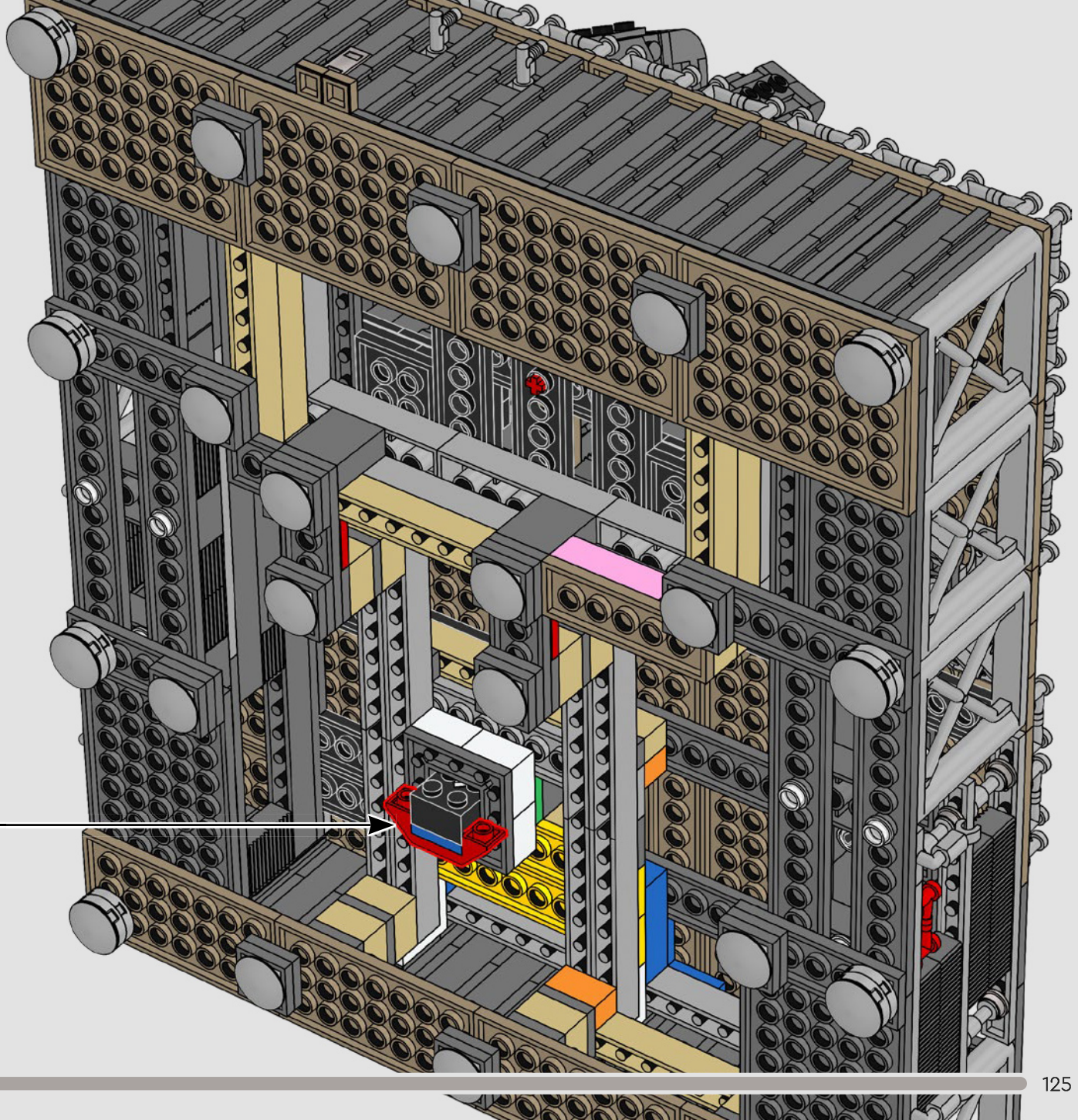
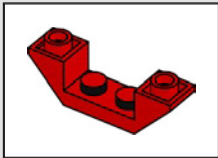



2x

171

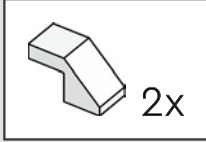

2x

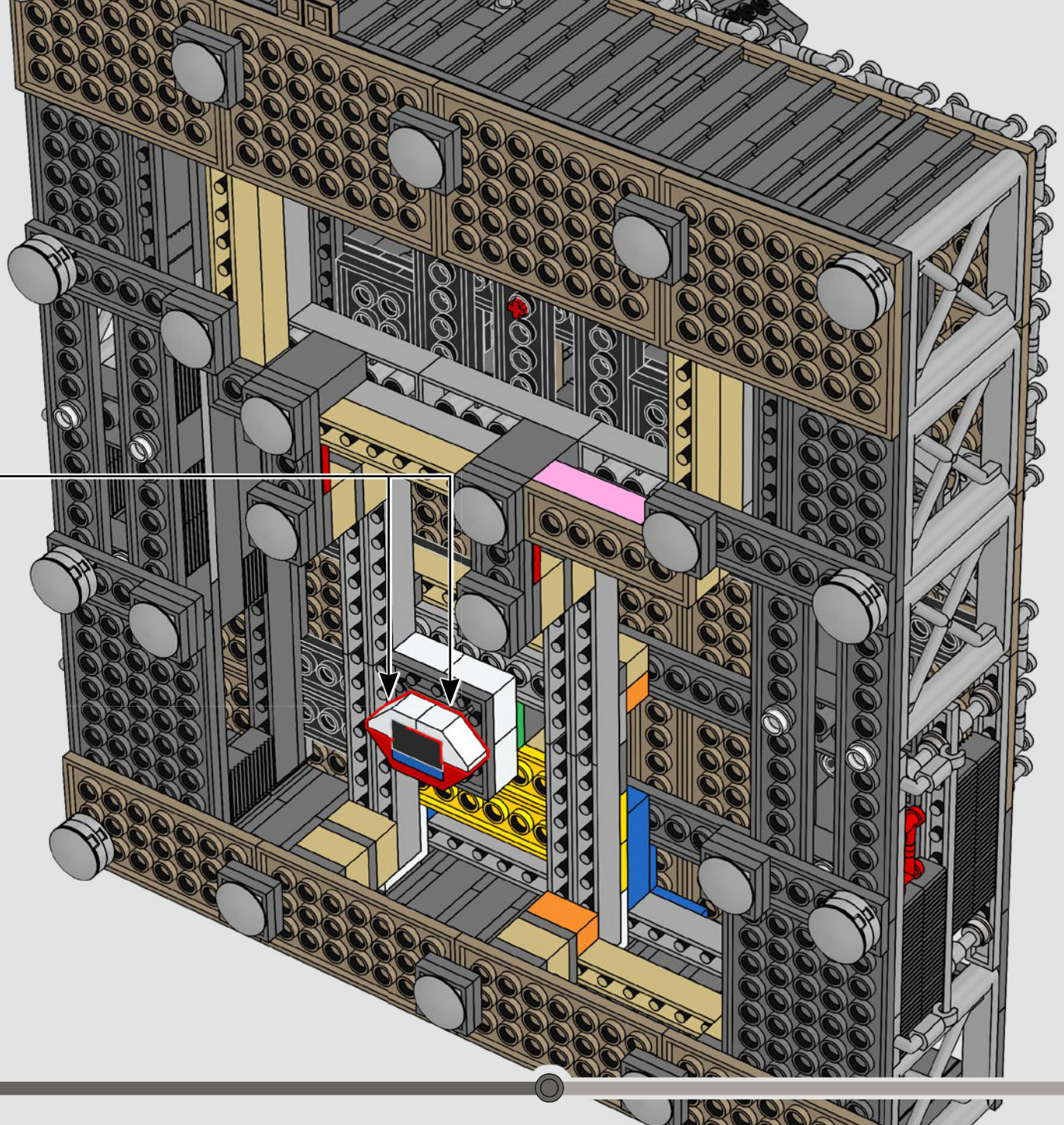

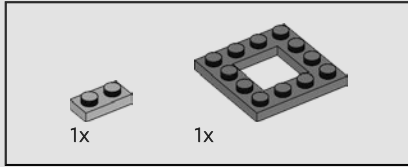
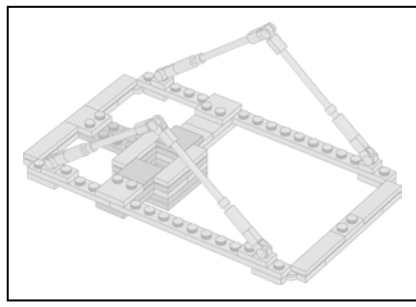

172

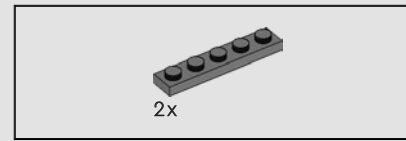
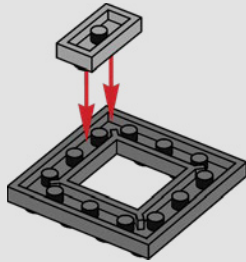

173

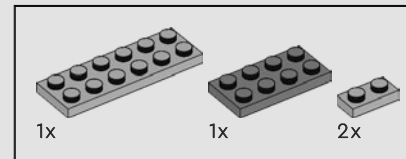
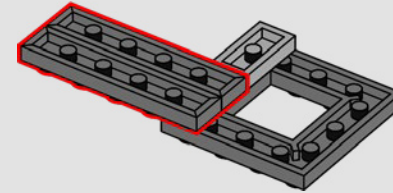

174

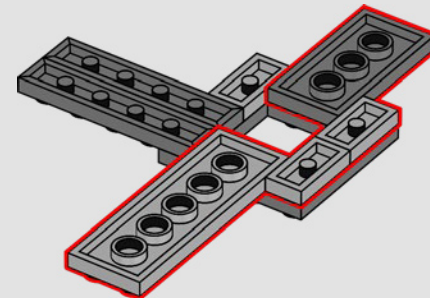

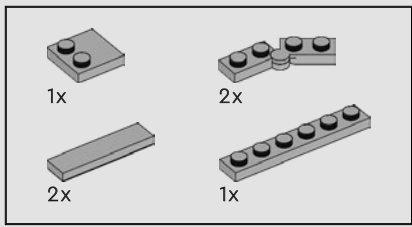

175

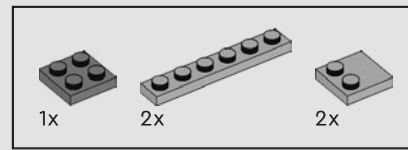
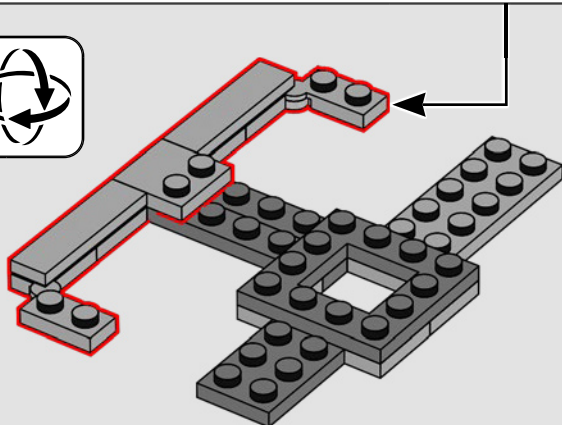
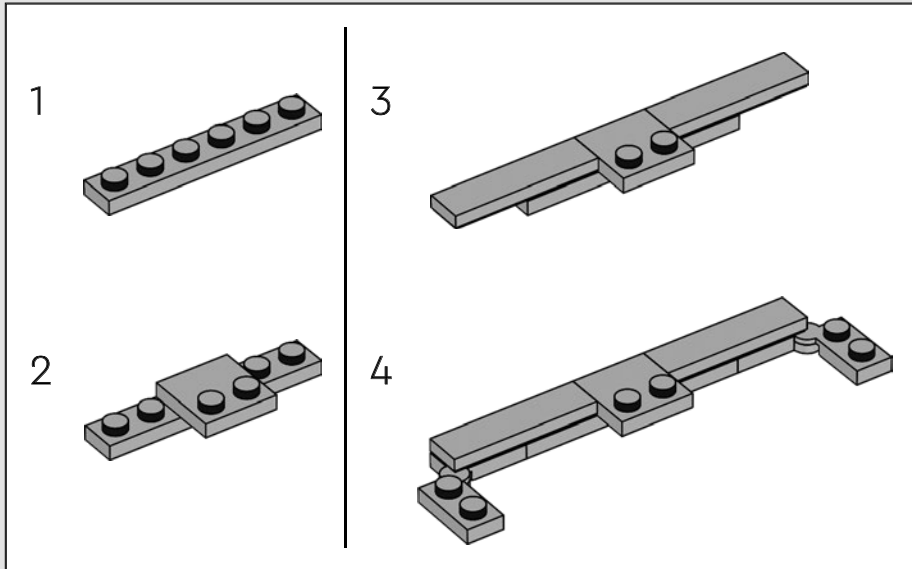

176

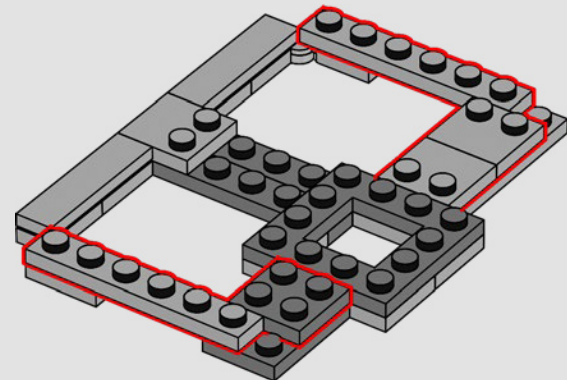

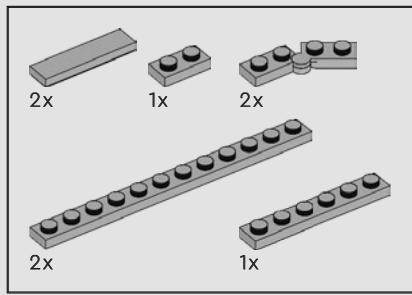

177

1

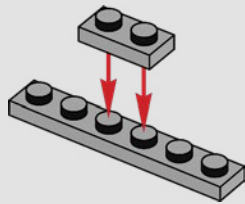

2

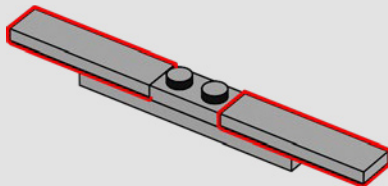

3

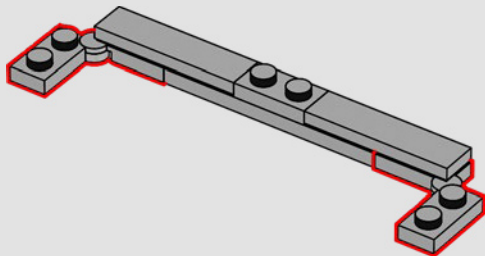

4

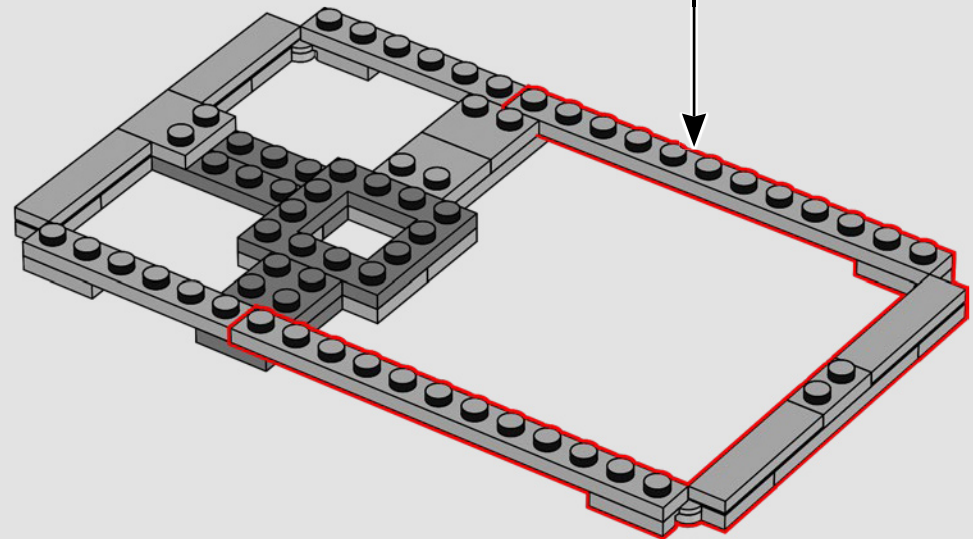
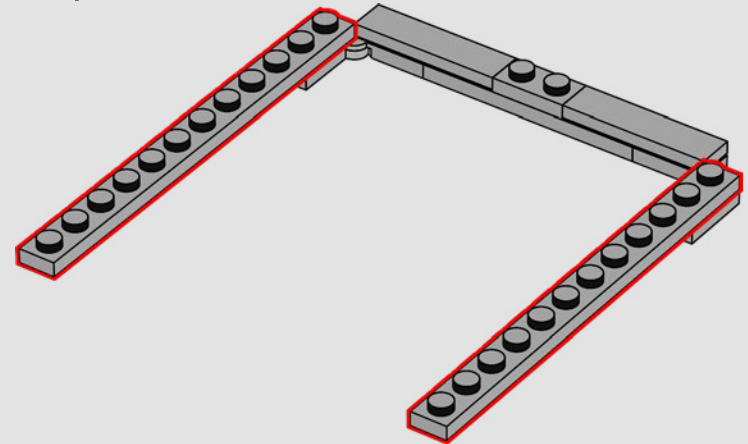

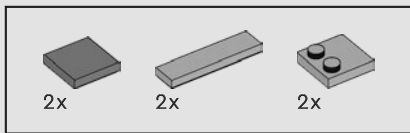

178

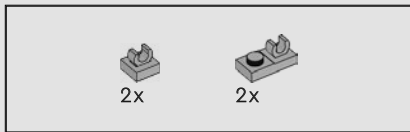
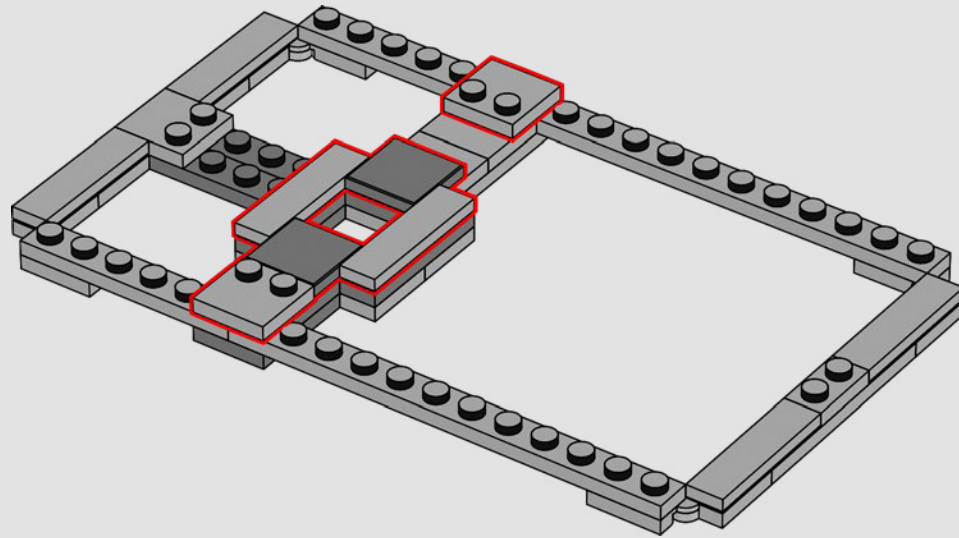

179

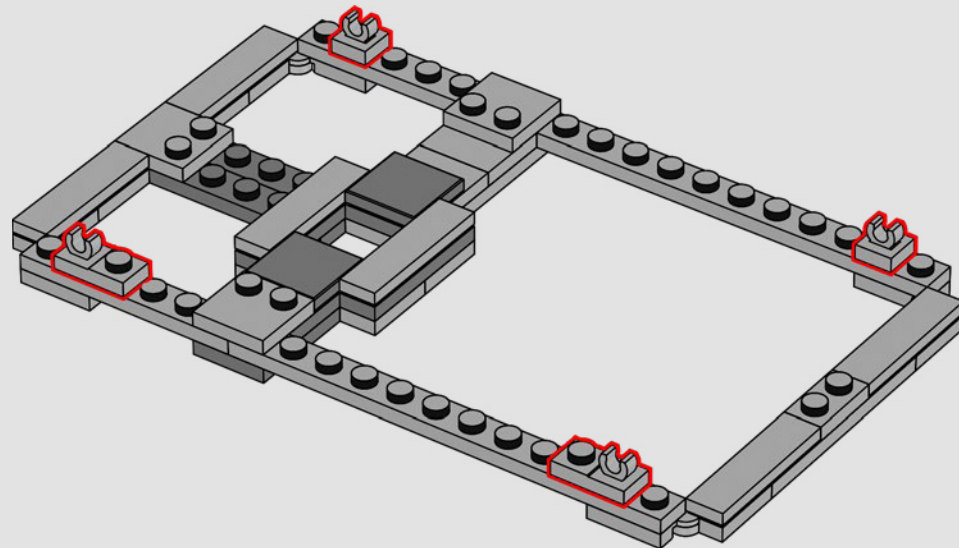

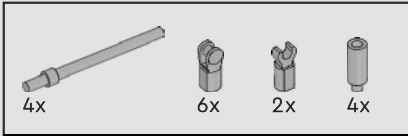
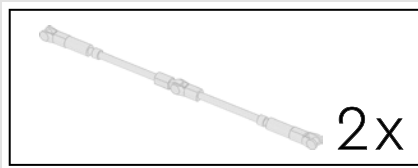

180

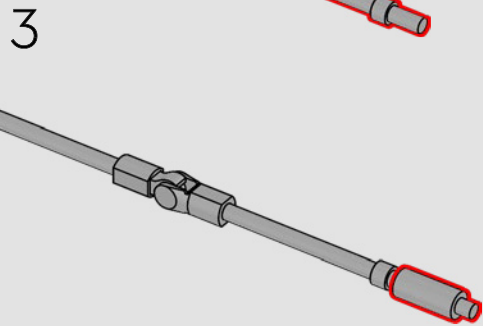
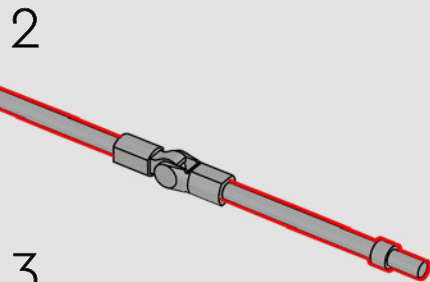
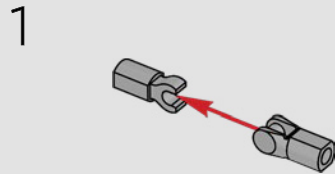

4

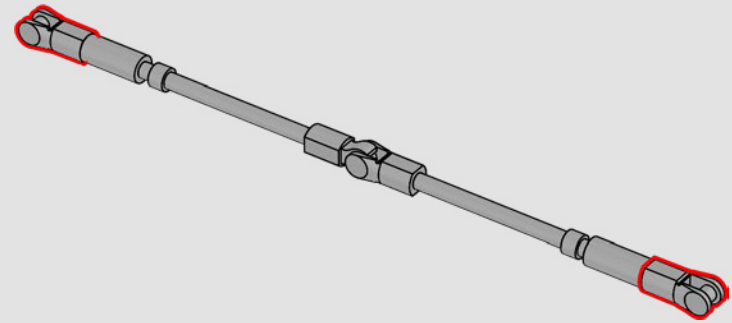

2x

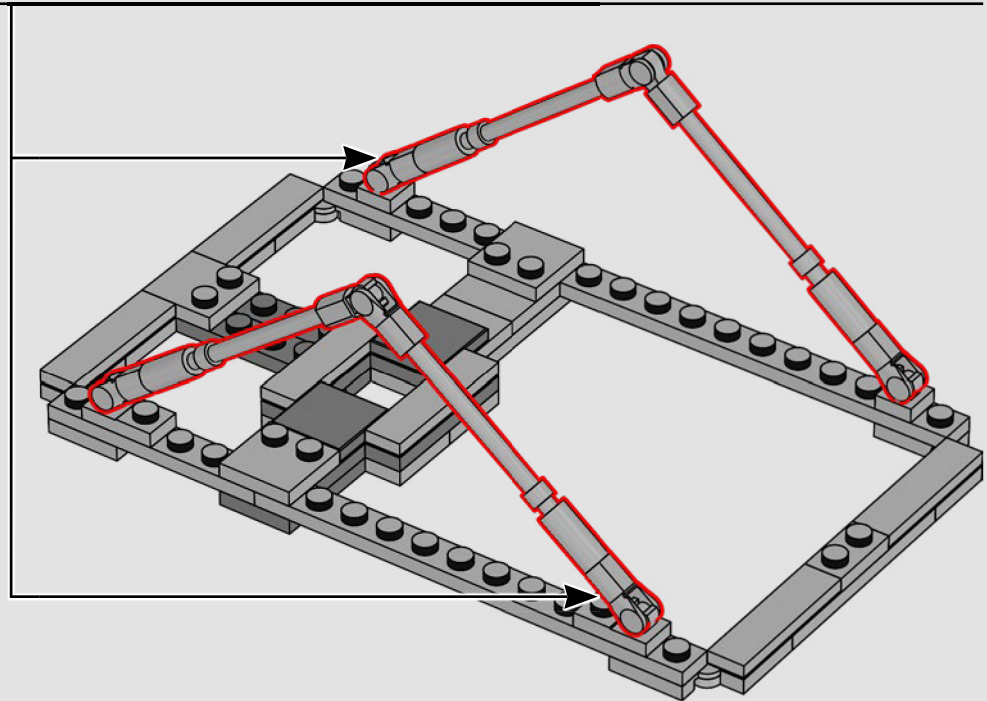

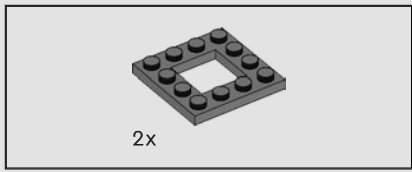

181

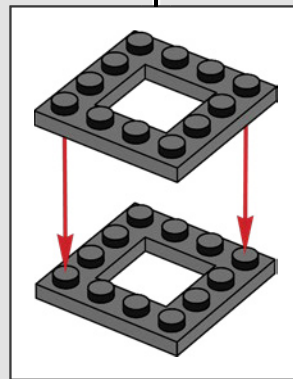
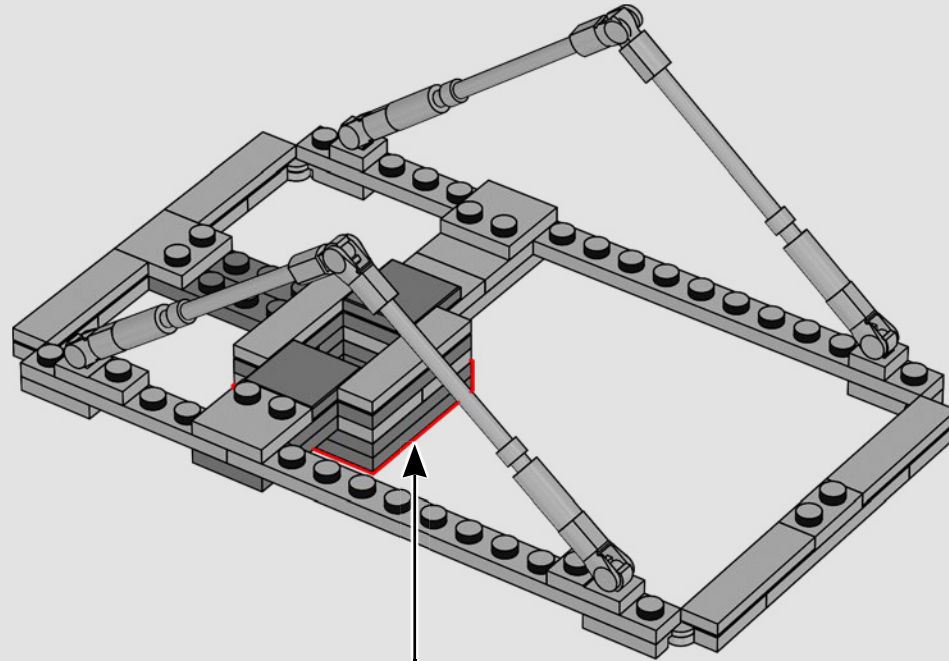

182

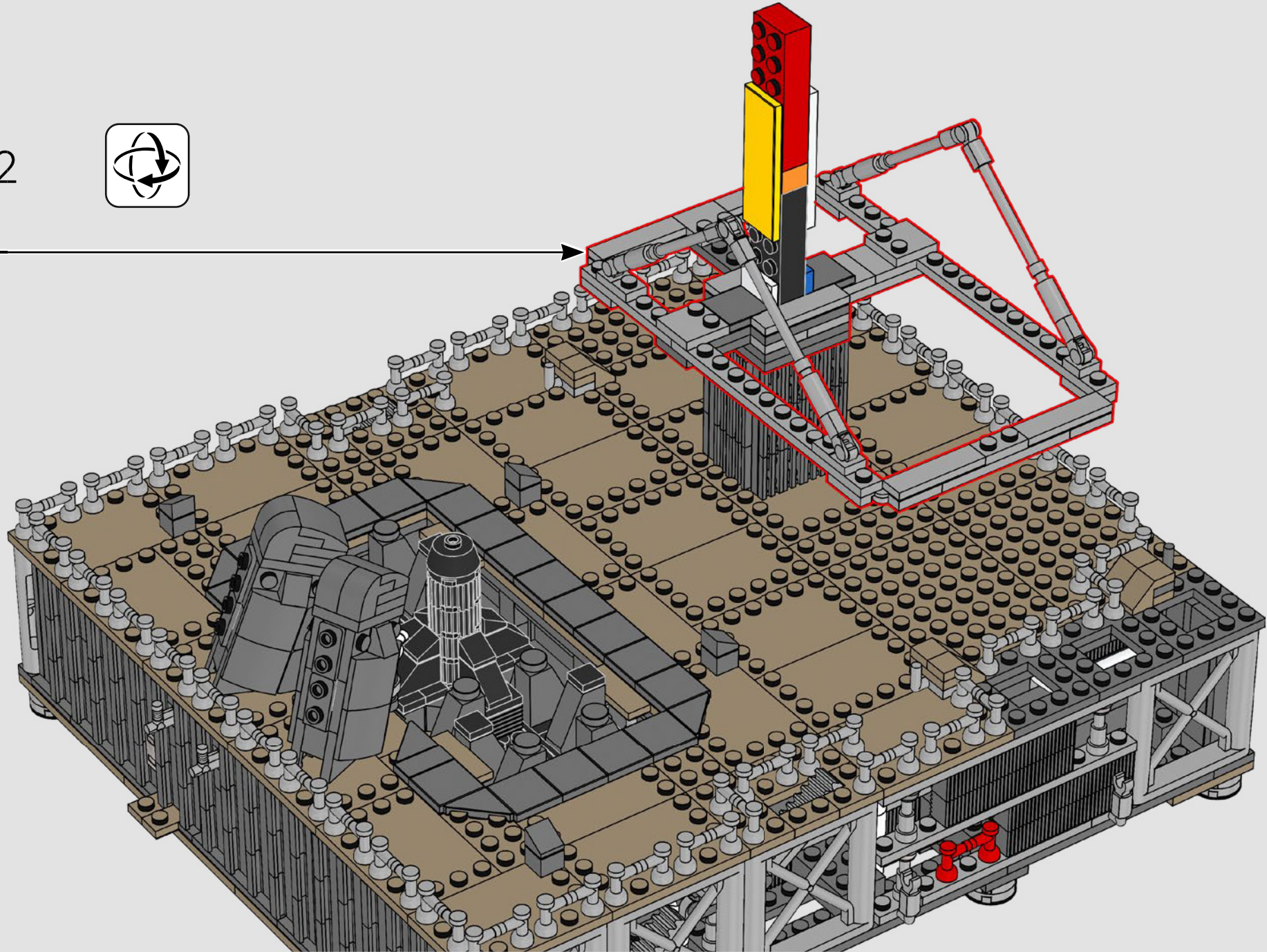

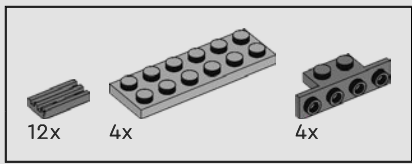

183

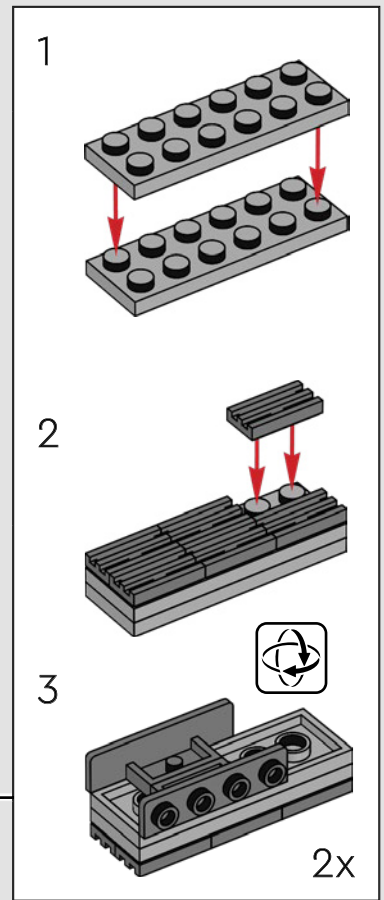
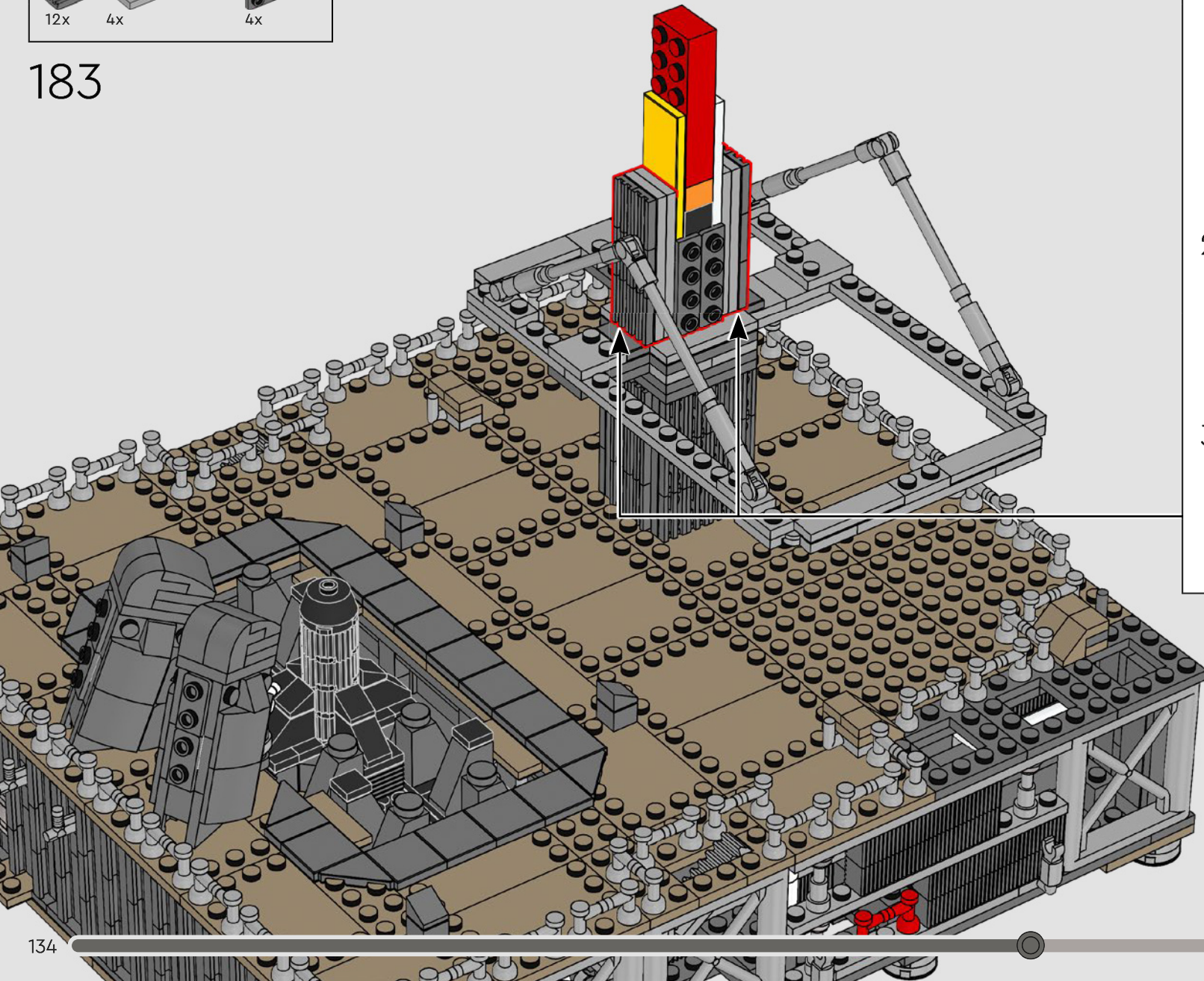

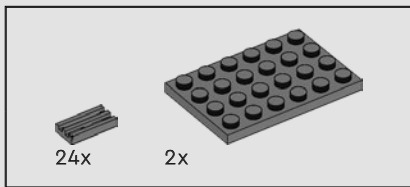

184

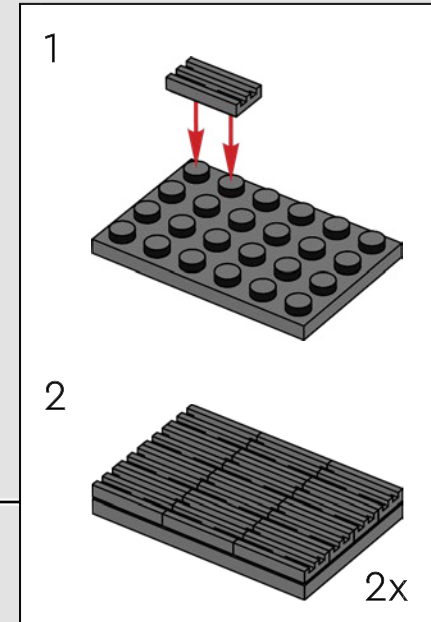
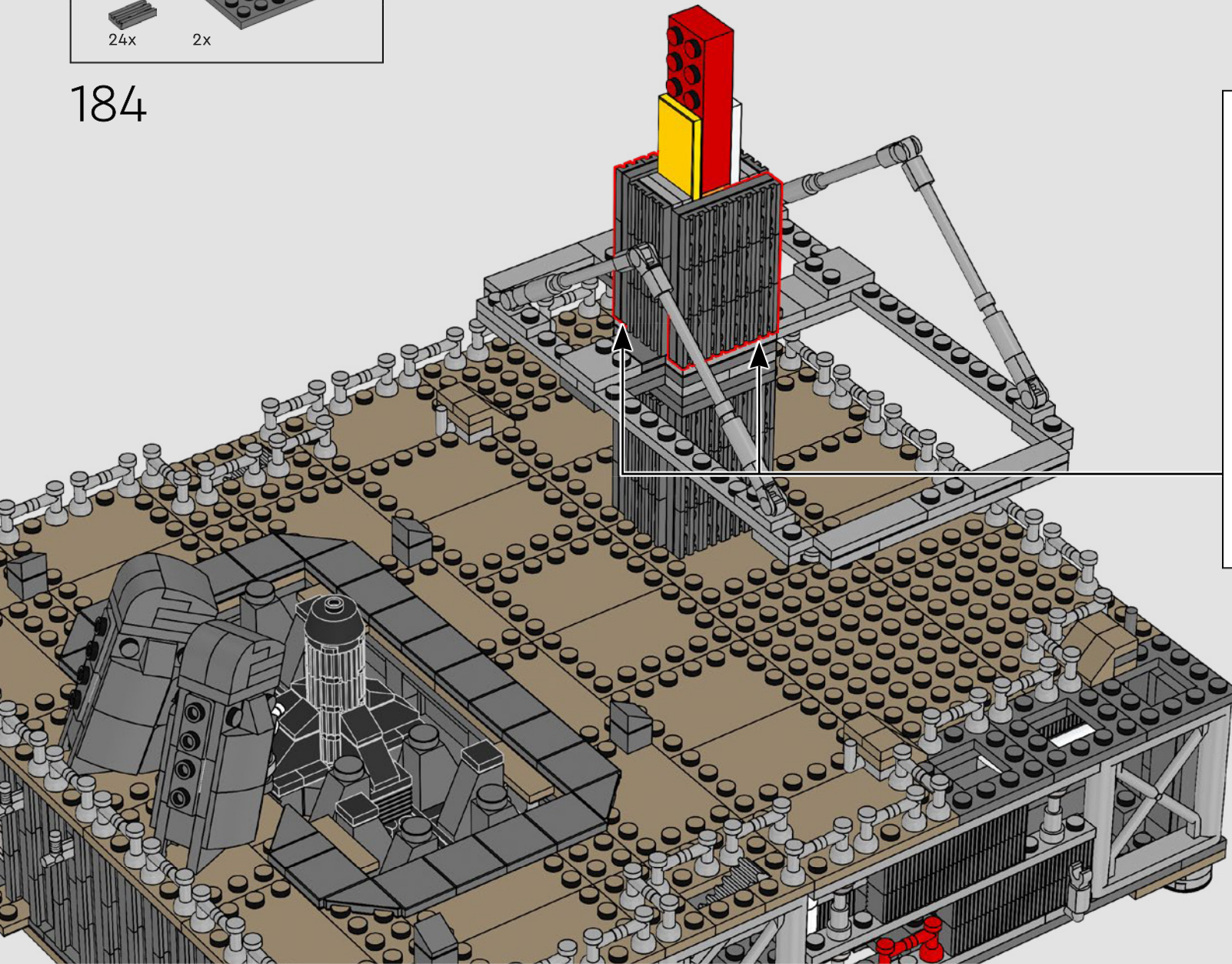

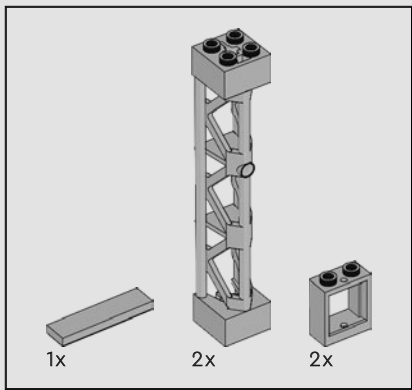

185

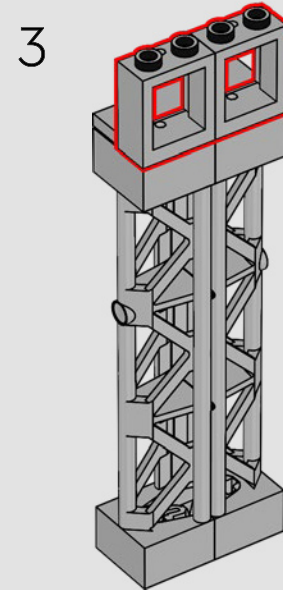
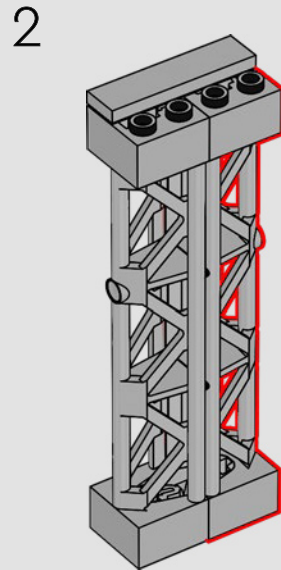
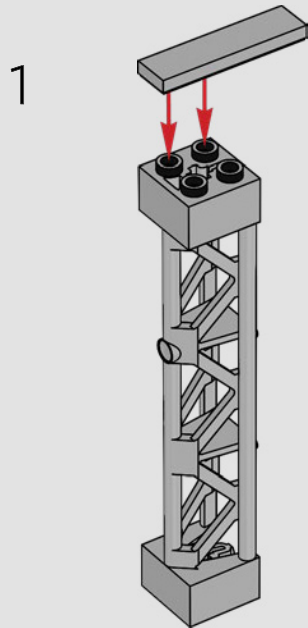

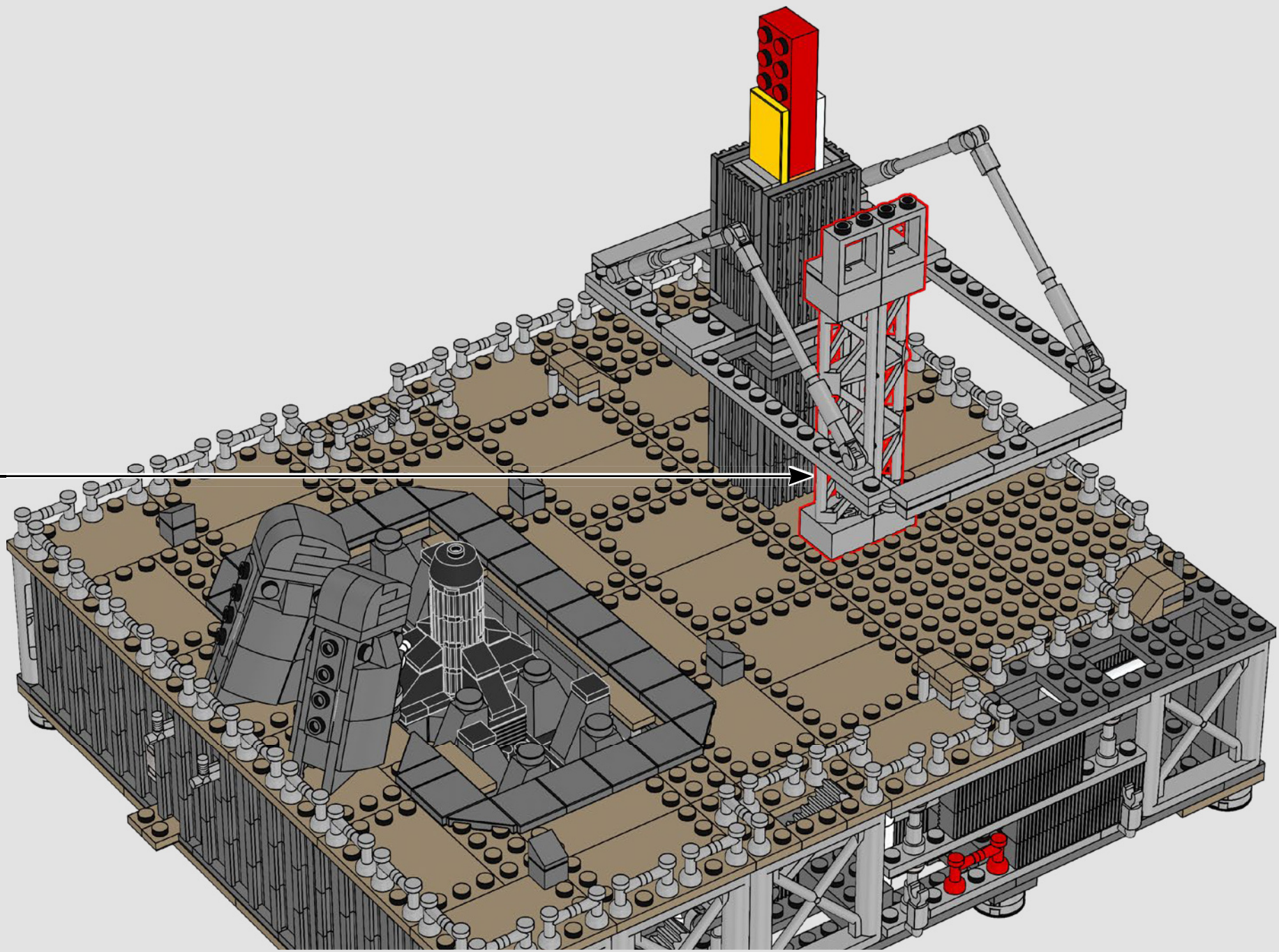

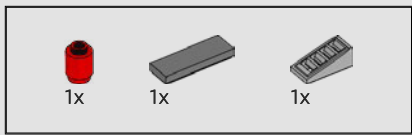

186

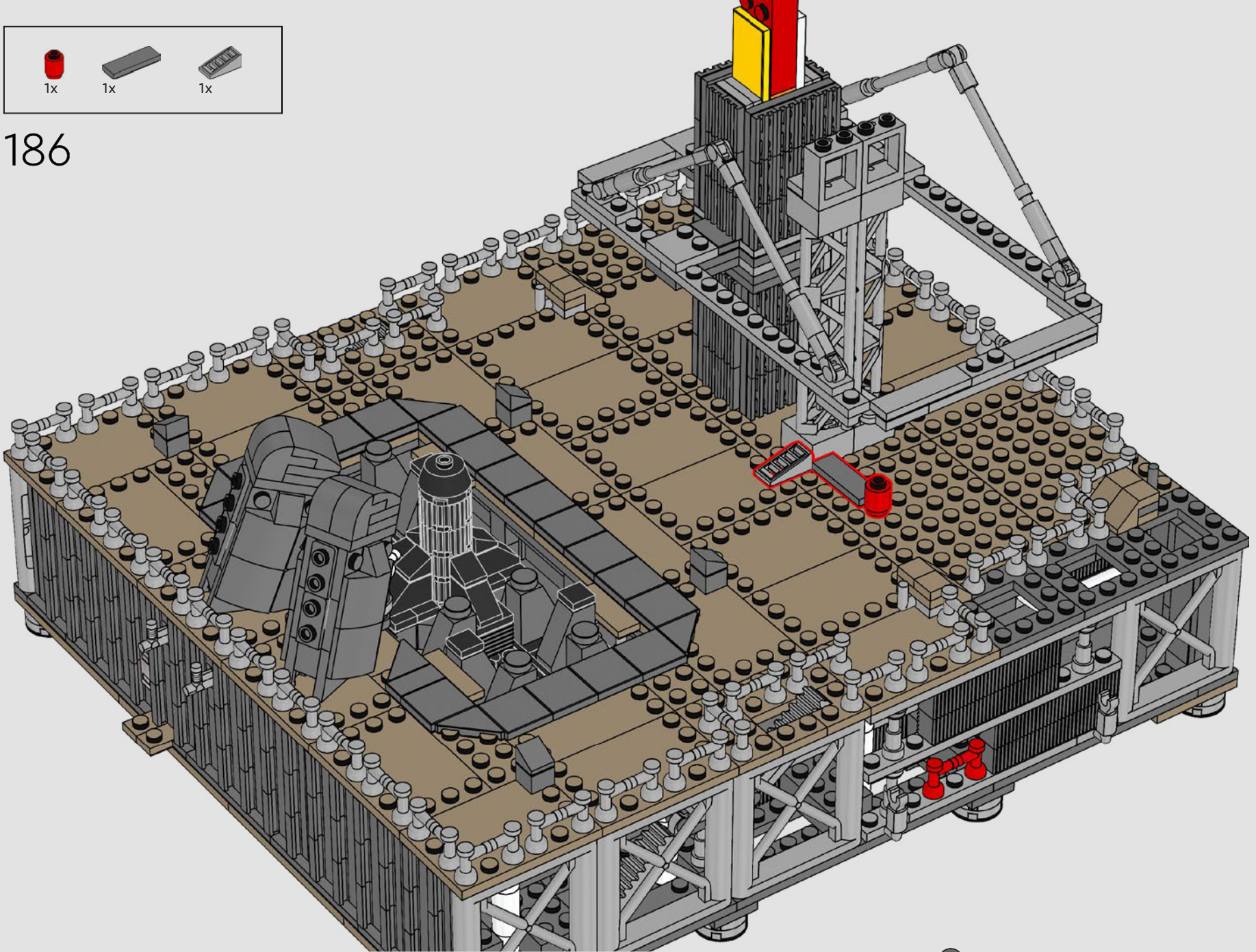

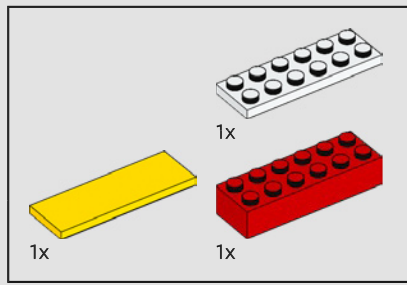

187

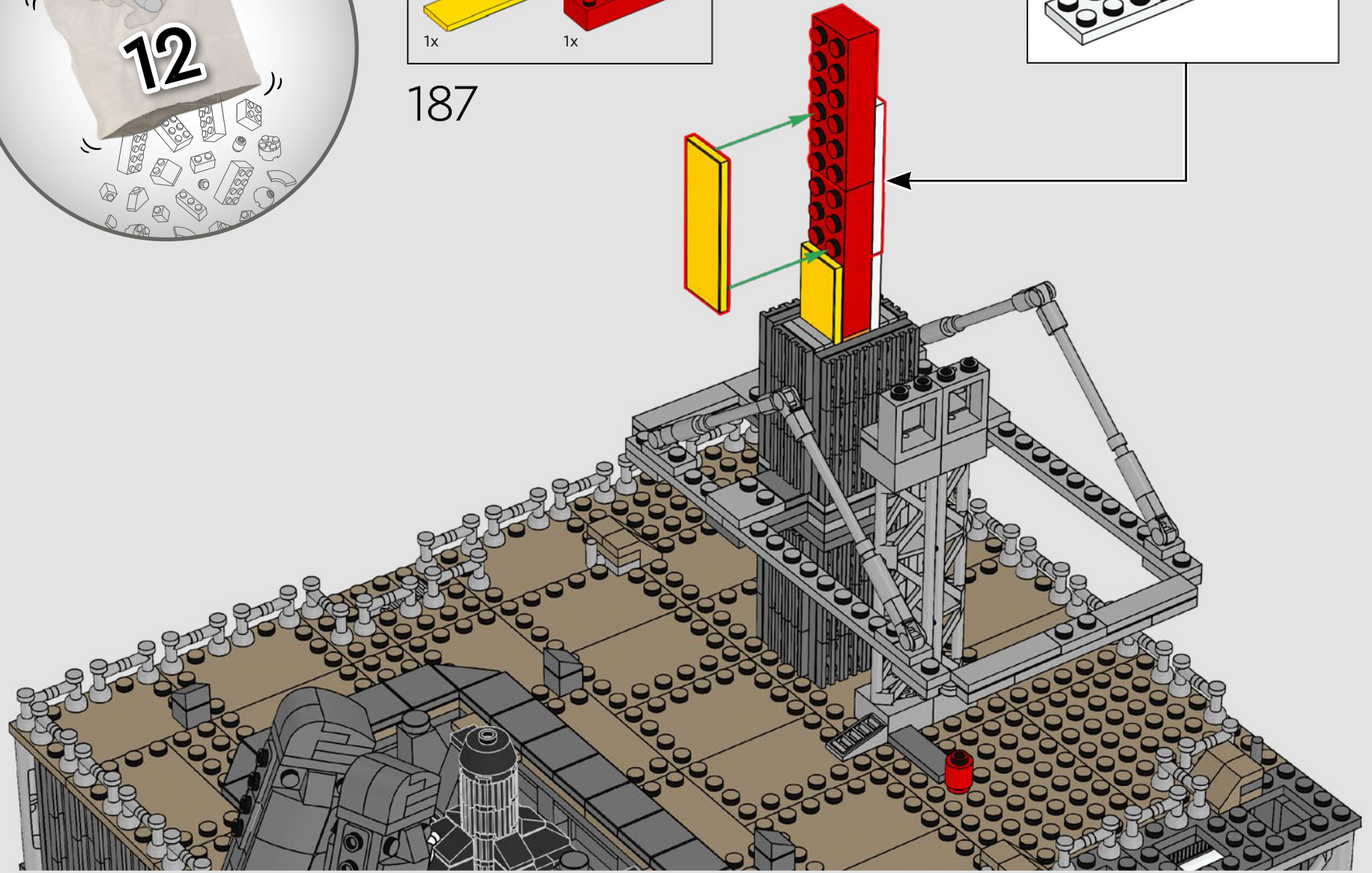
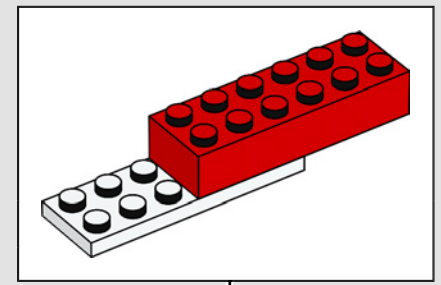

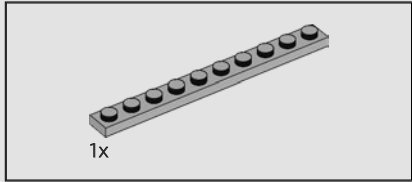
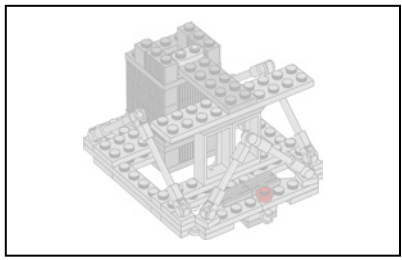

188

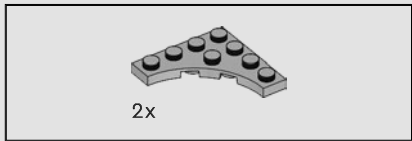
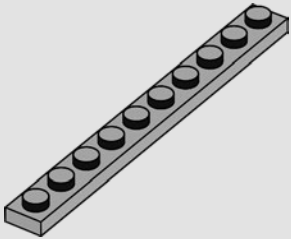

189

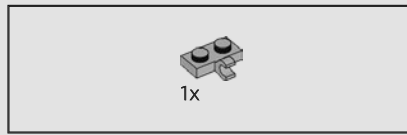
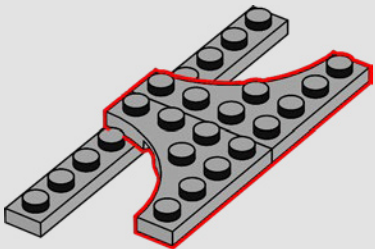

190

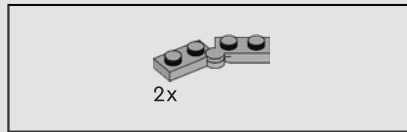
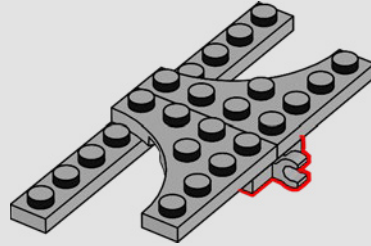

191

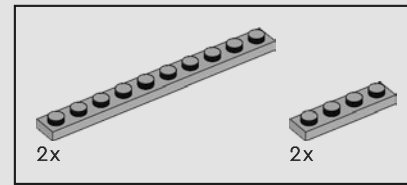
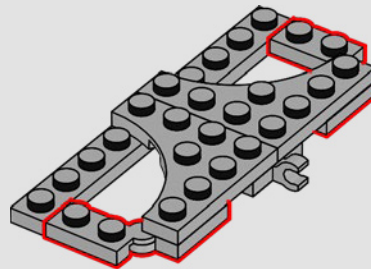

192

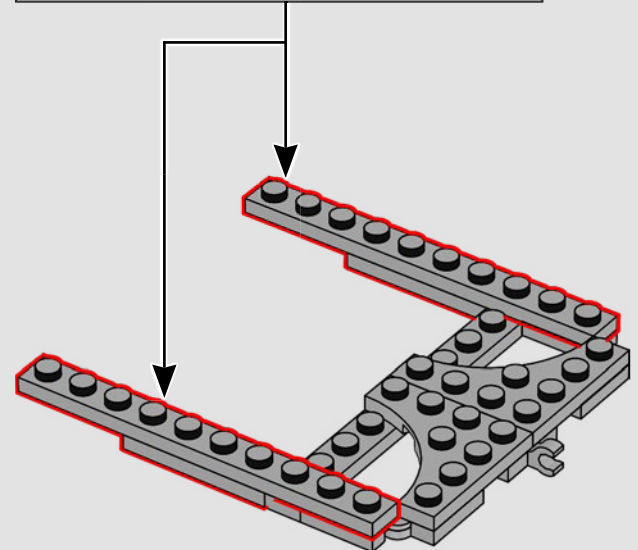
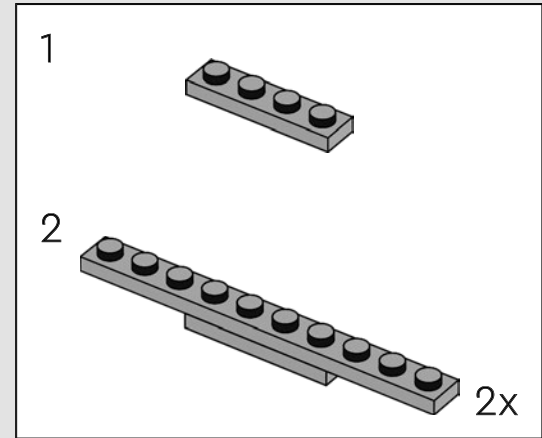

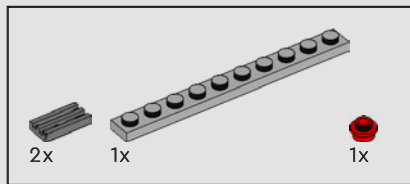

193

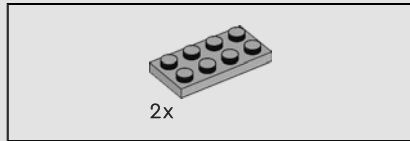
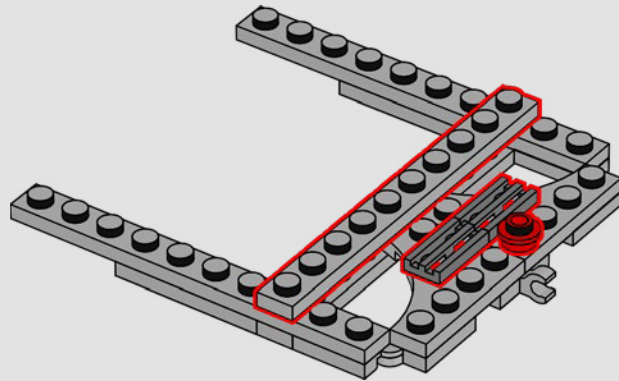

194

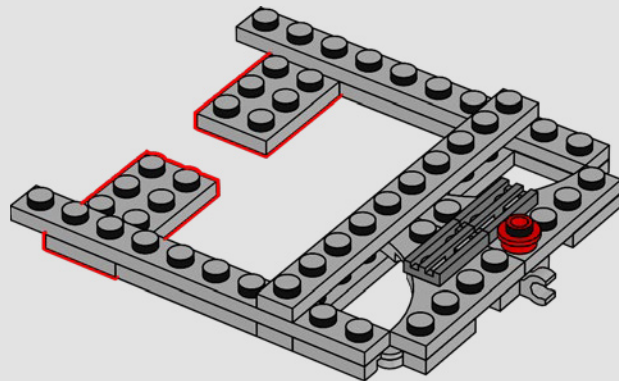

195

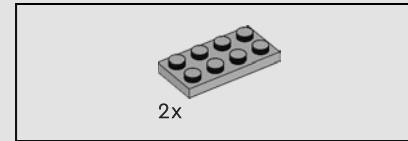
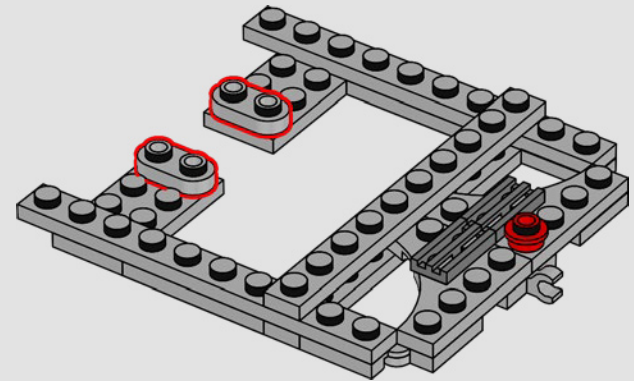

196

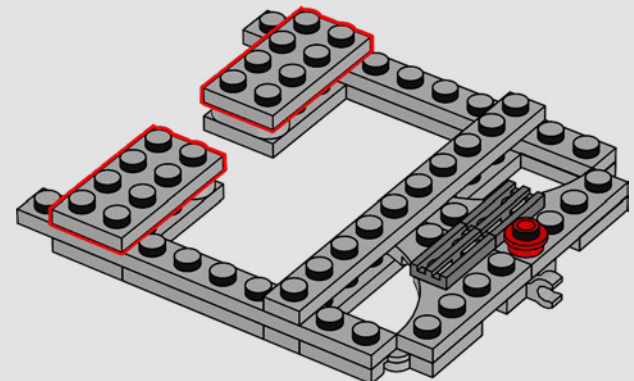

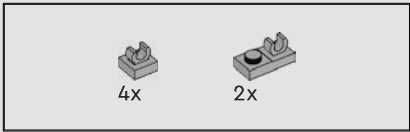

197

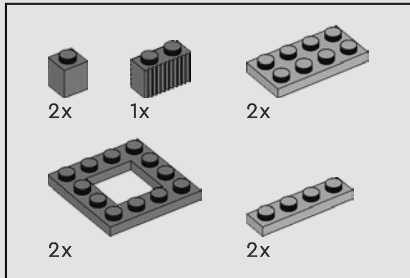
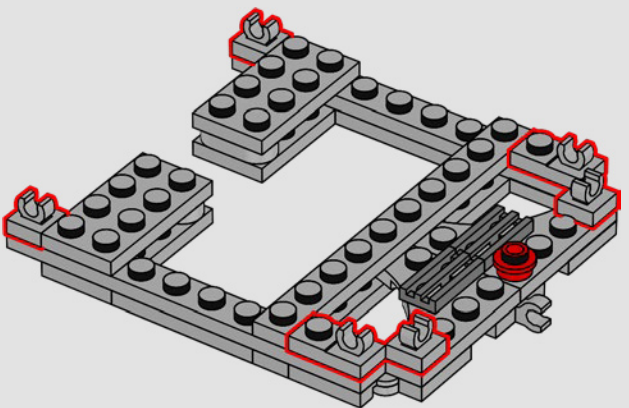

198

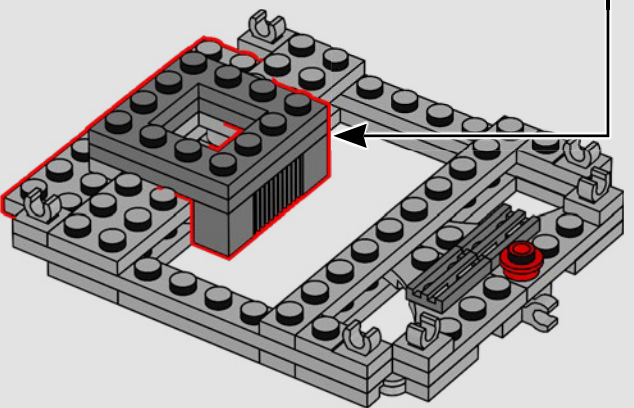
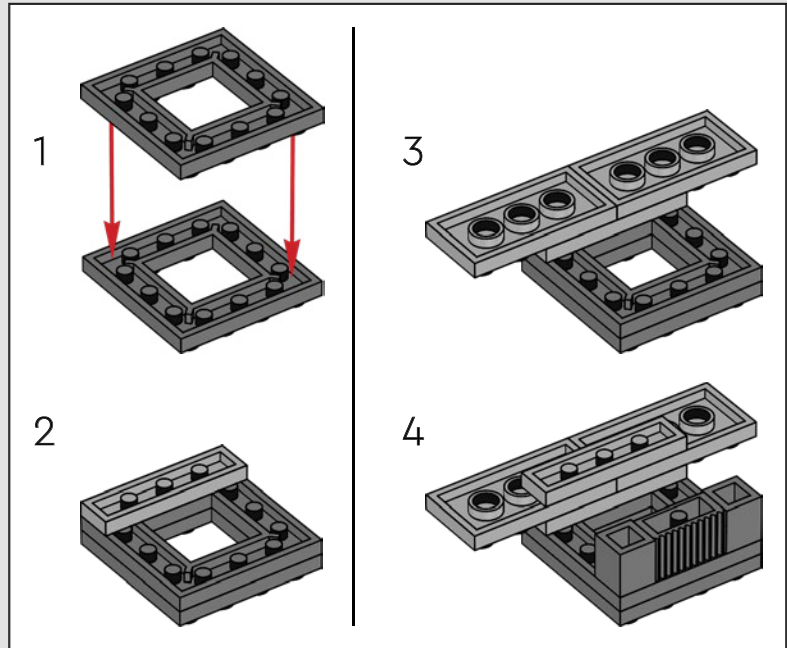

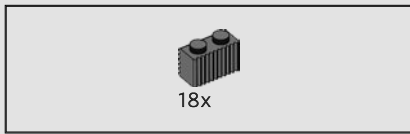

199

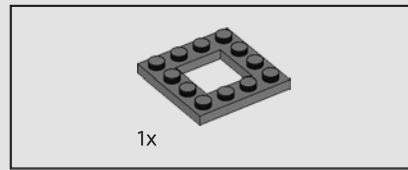
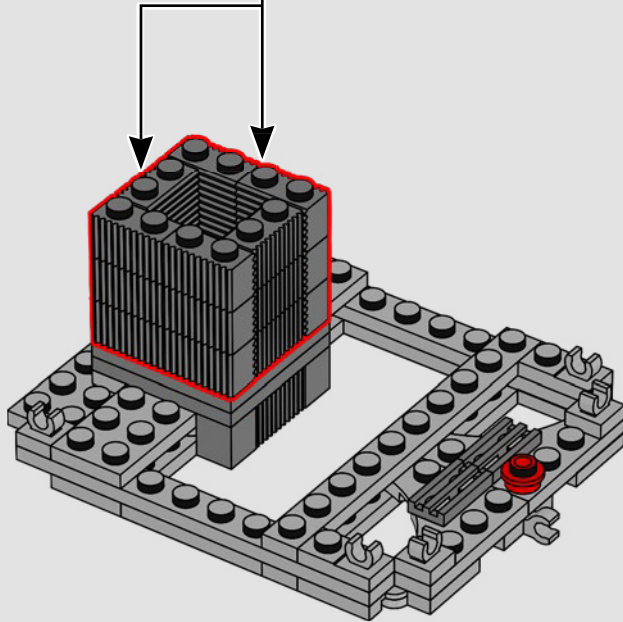
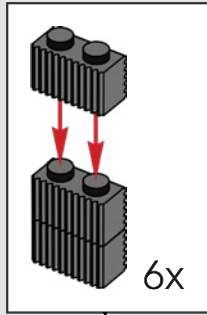

200

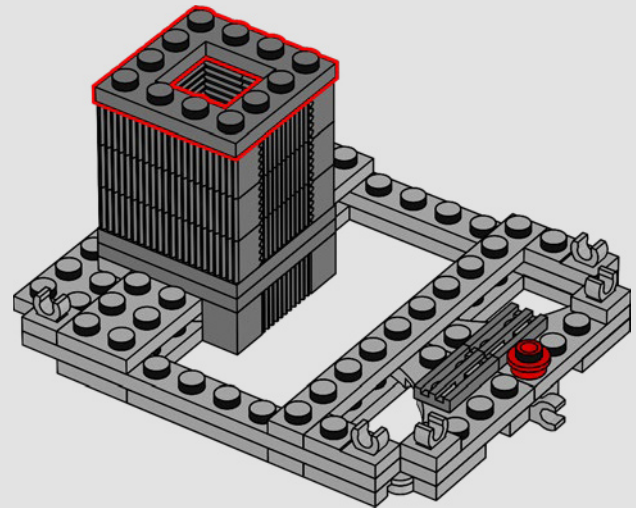

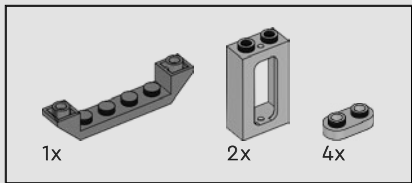

201

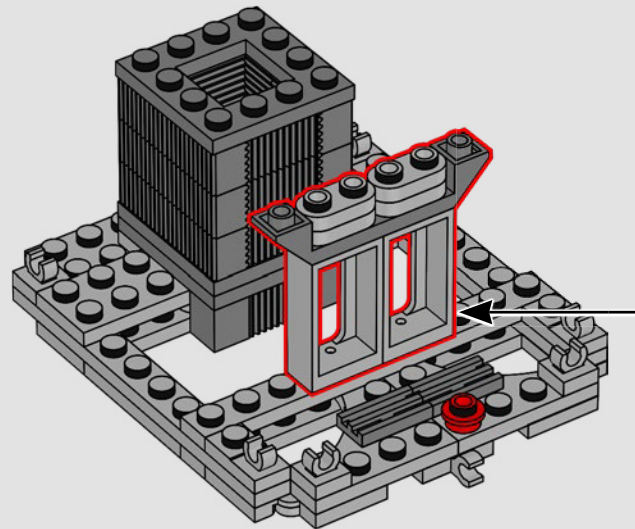
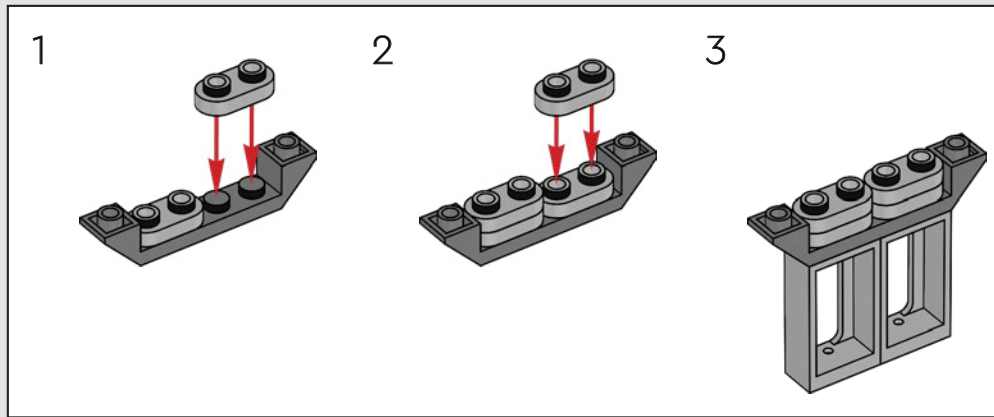

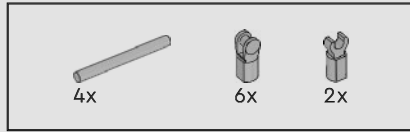
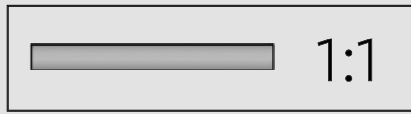
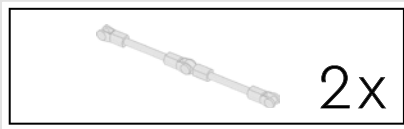

202

1

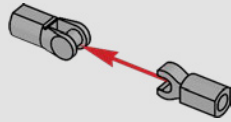

2

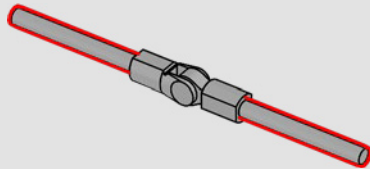

3

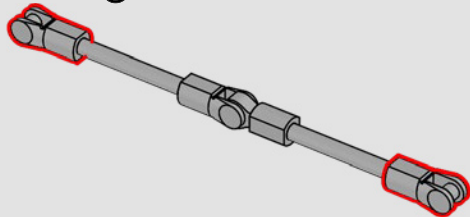

2x

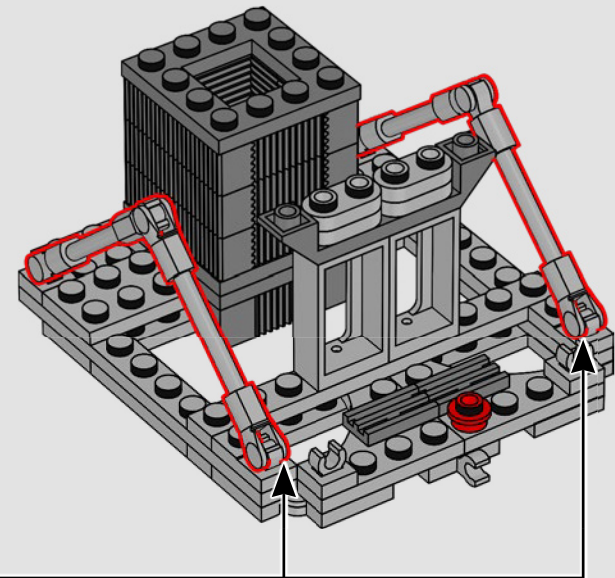
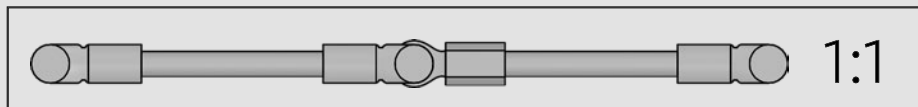



203

1

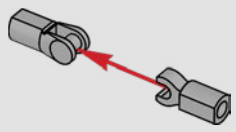

2

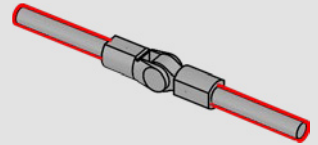

3

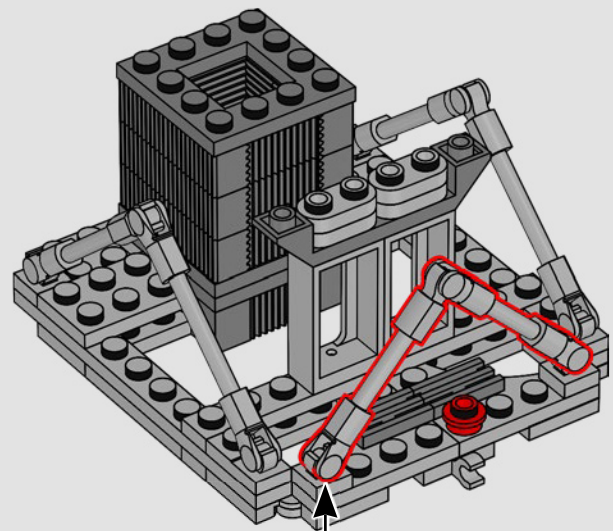
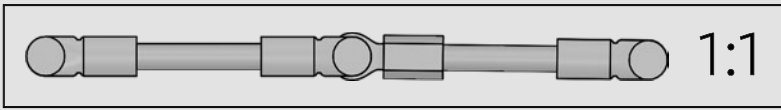
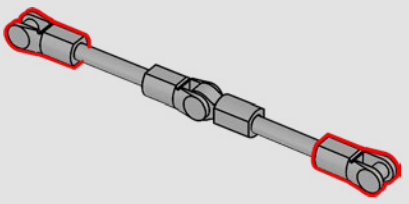

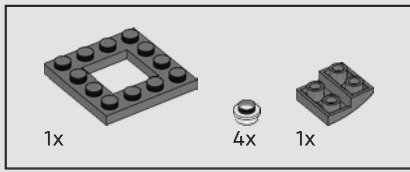

204

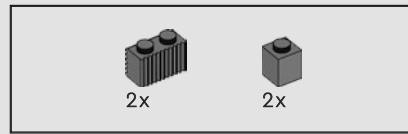
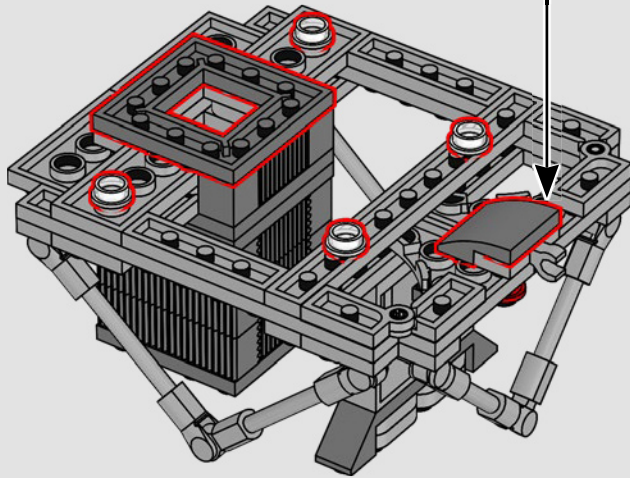
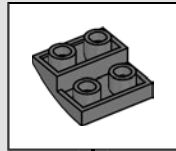

205

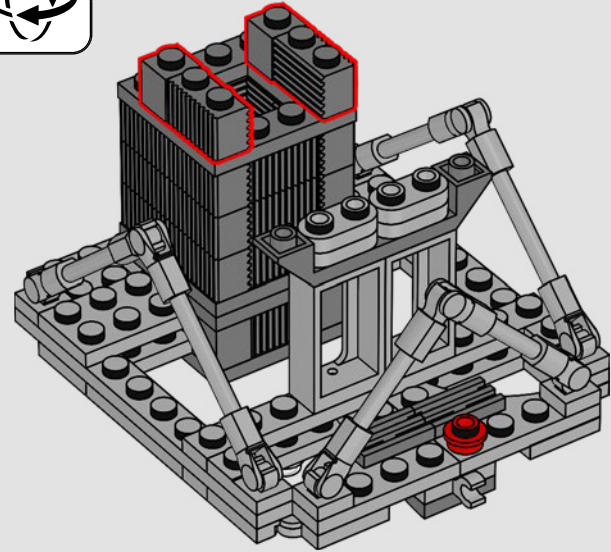

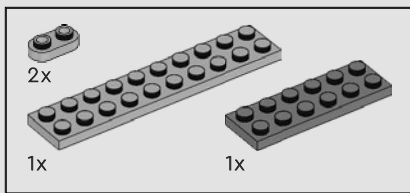

206

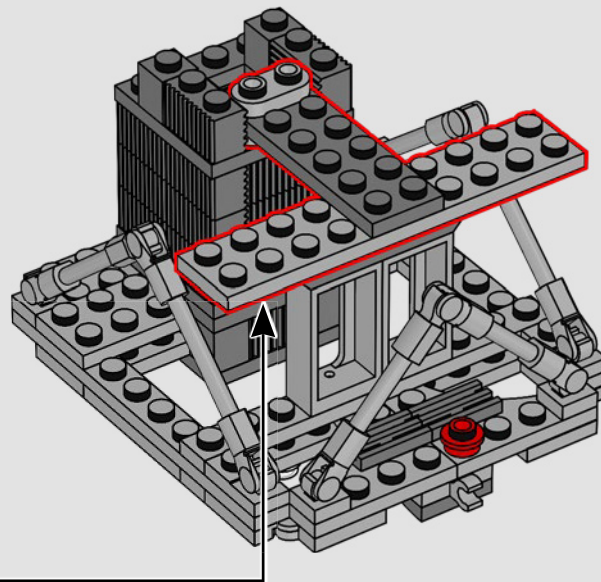
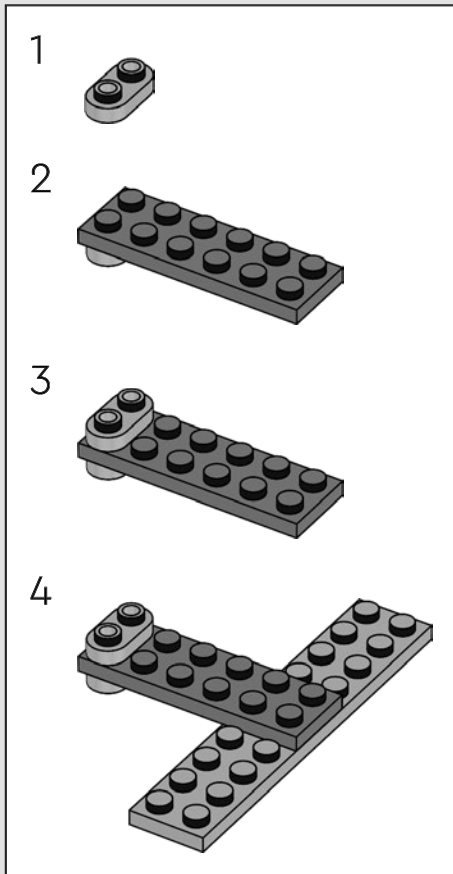

207

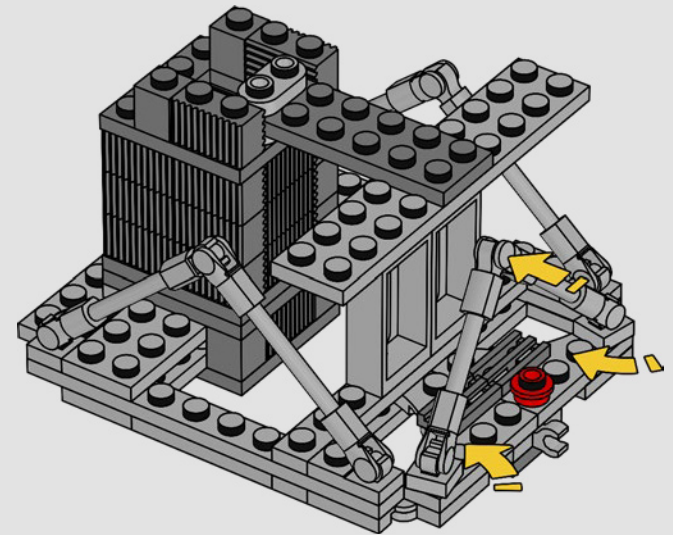

208

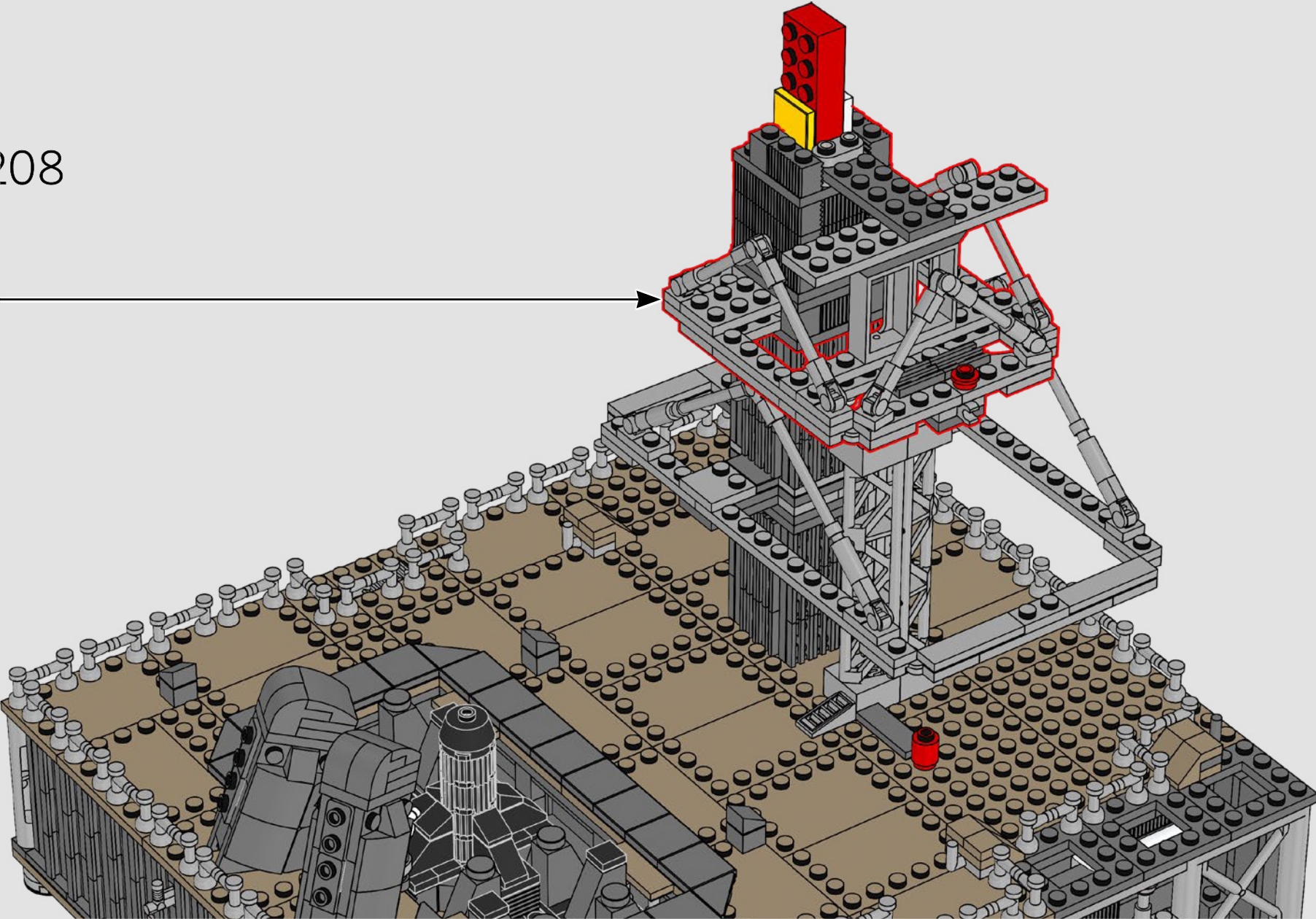

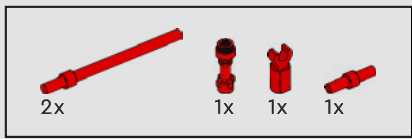

209

1

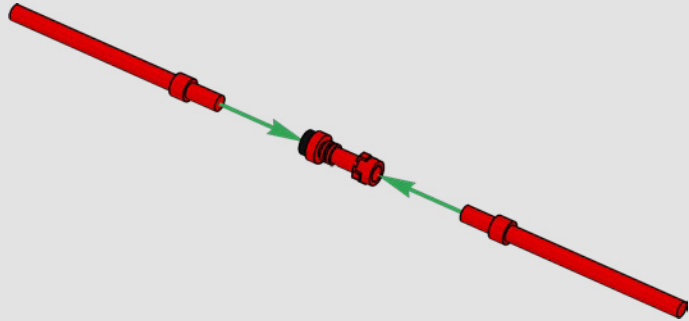

2

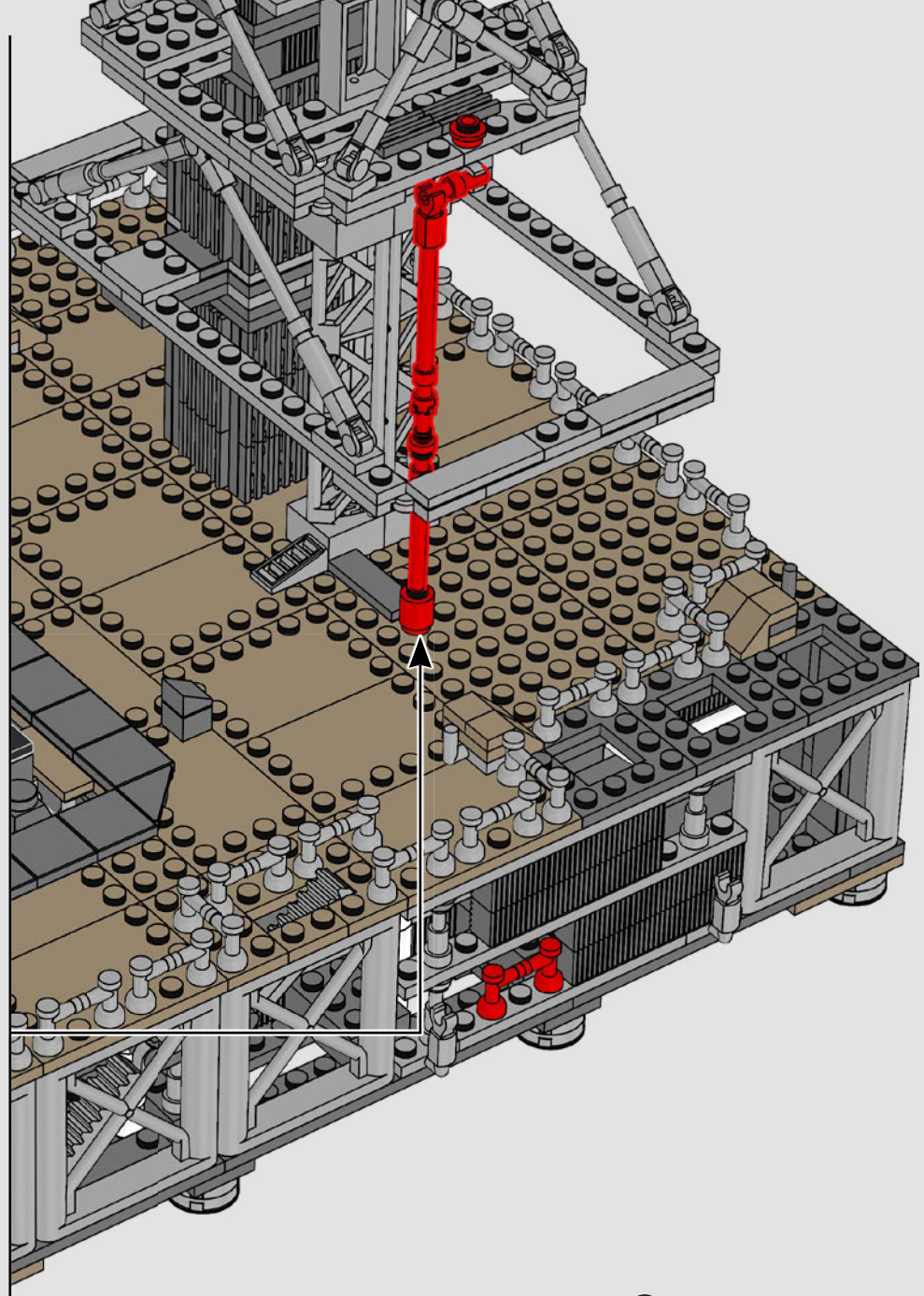
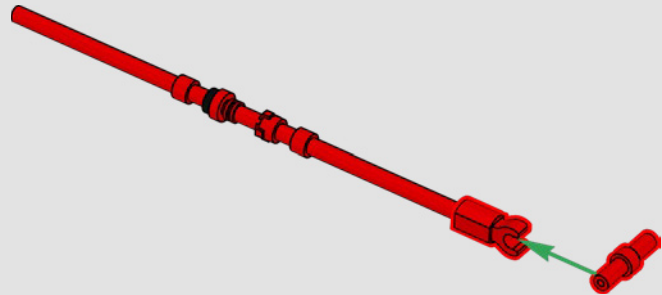

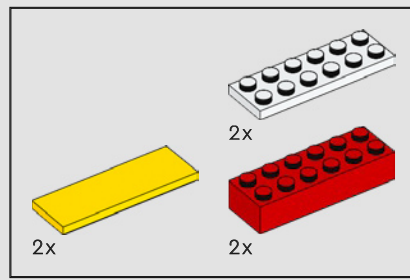

210

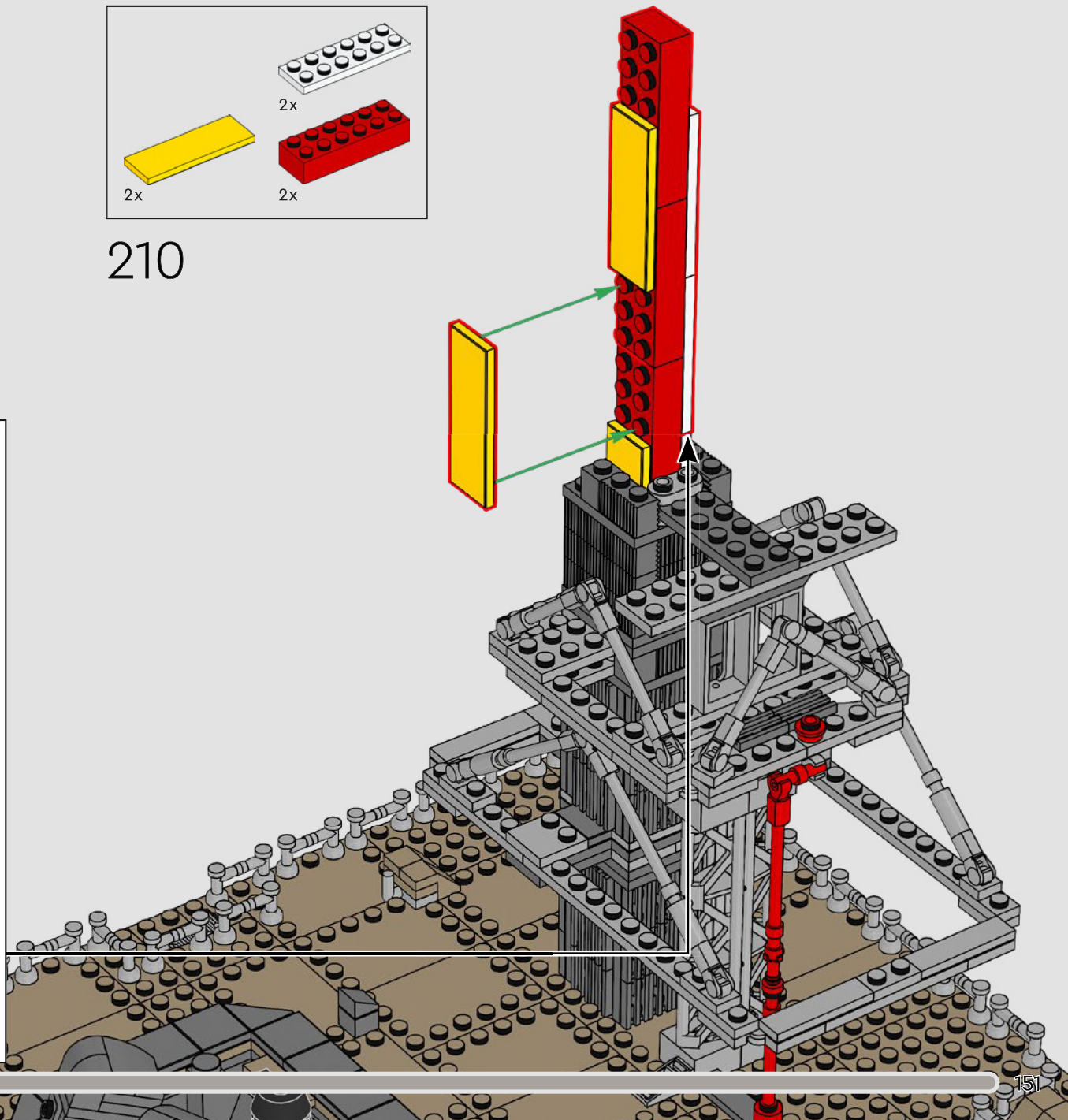
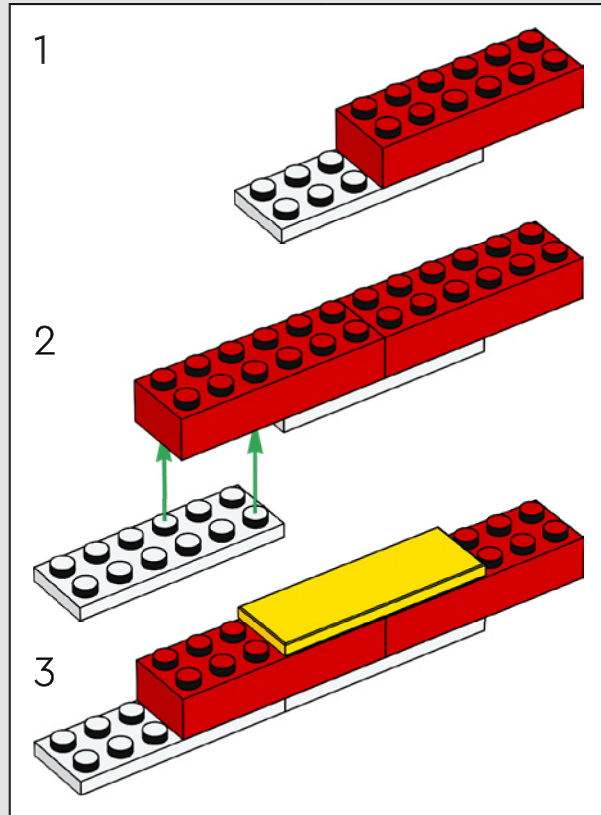

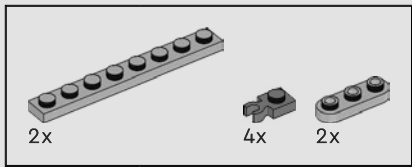

211

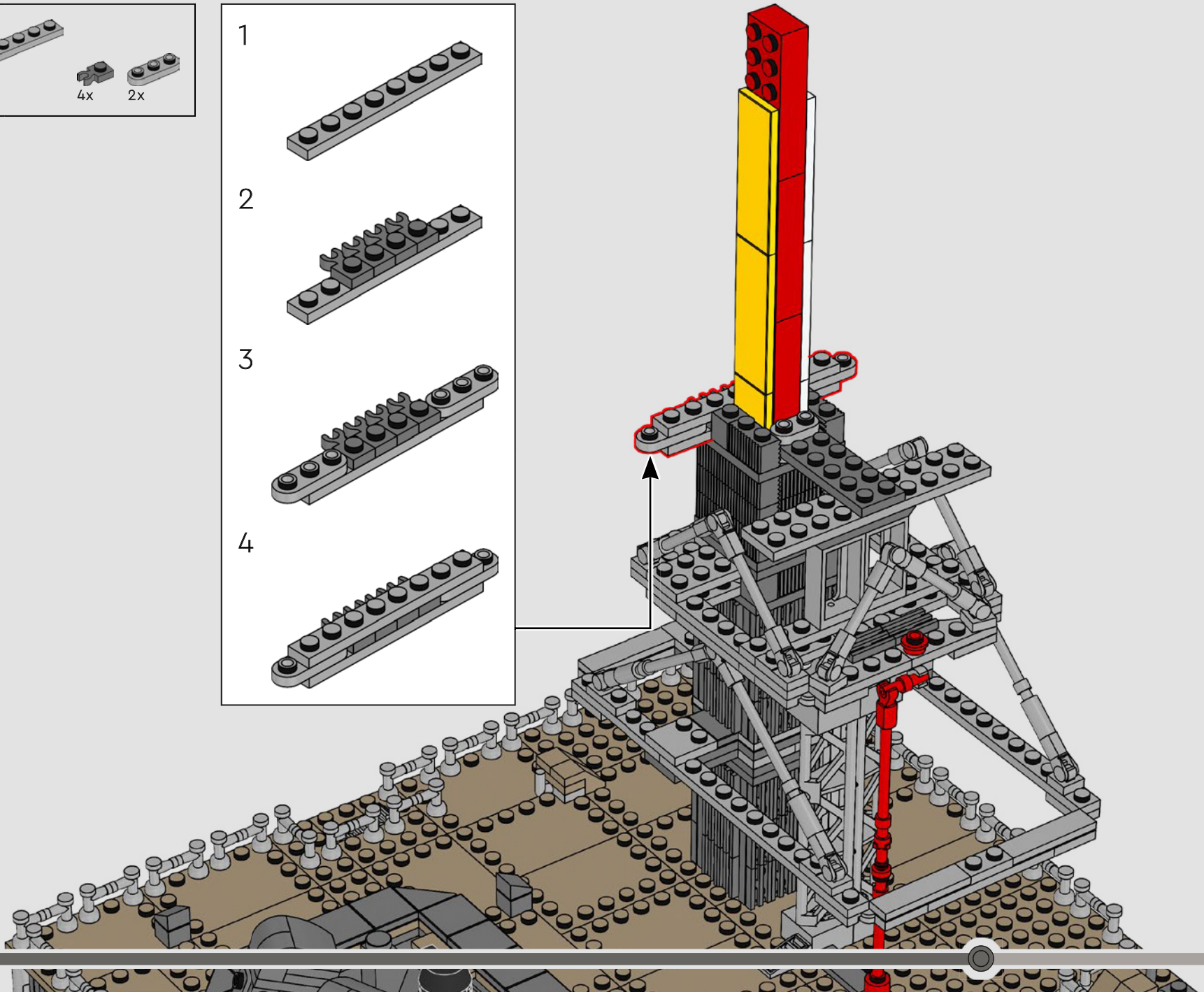
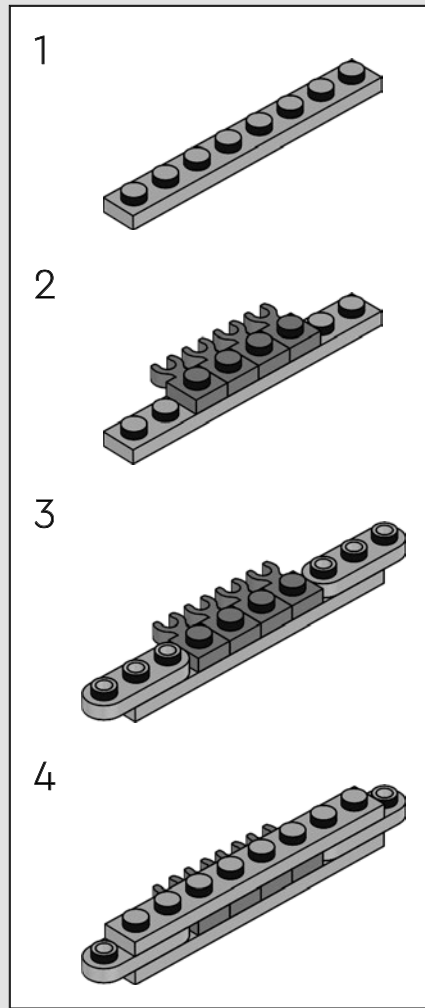

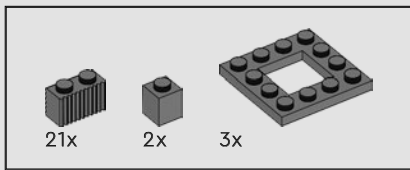

212

1

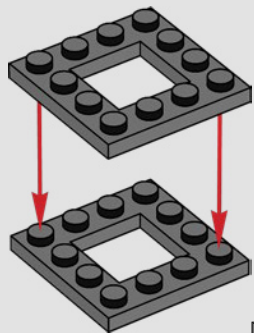

2

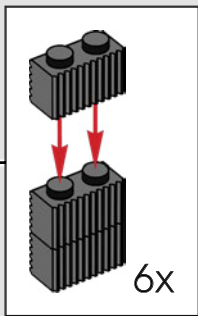
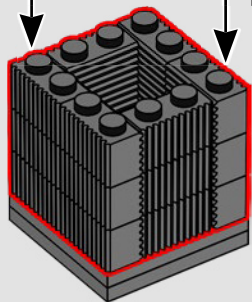

3

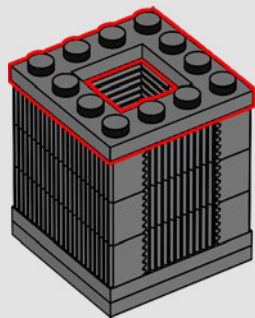

4

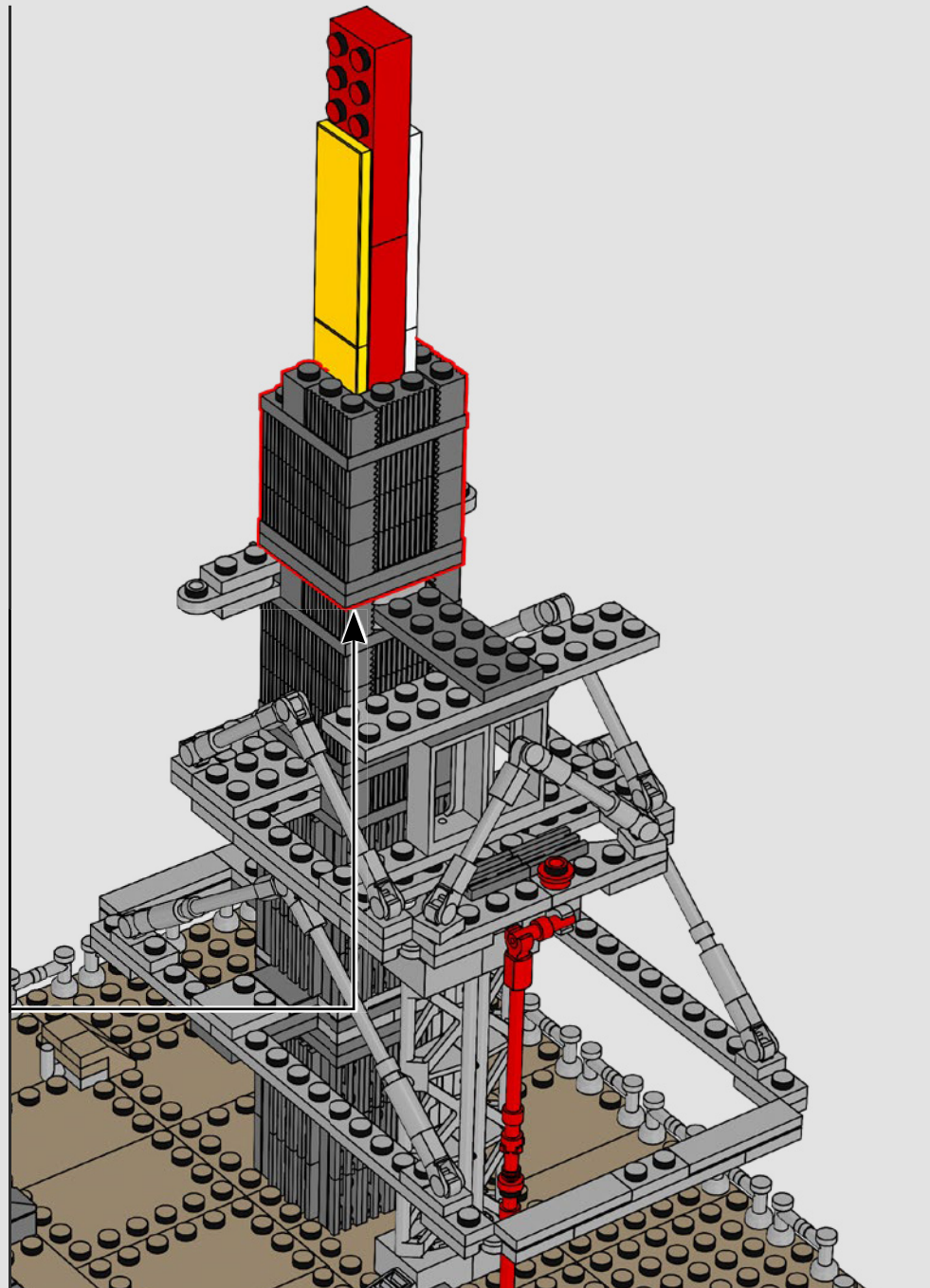
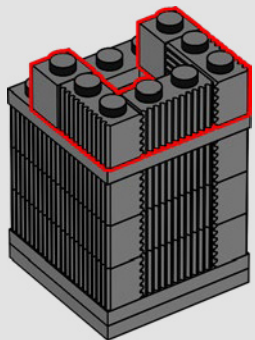

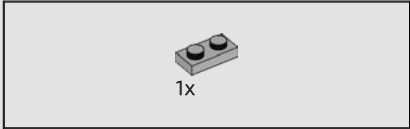
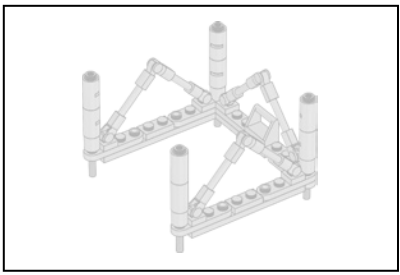

213

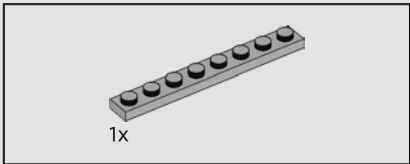
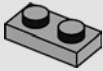

214

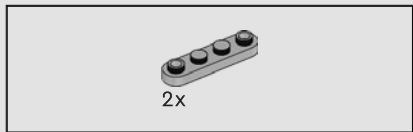
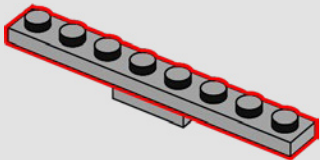

215

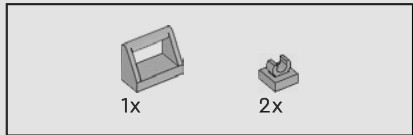
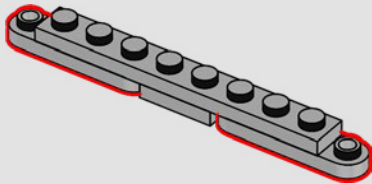

216

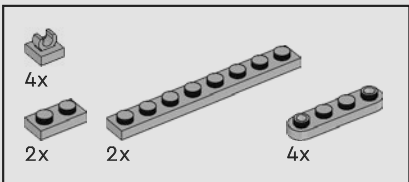
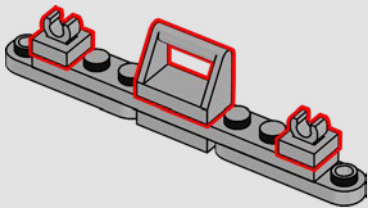

217

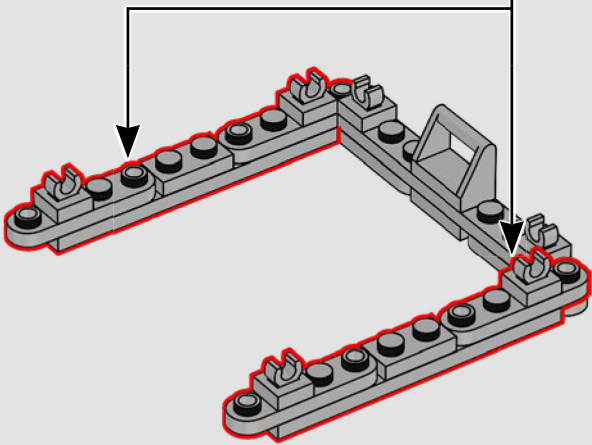
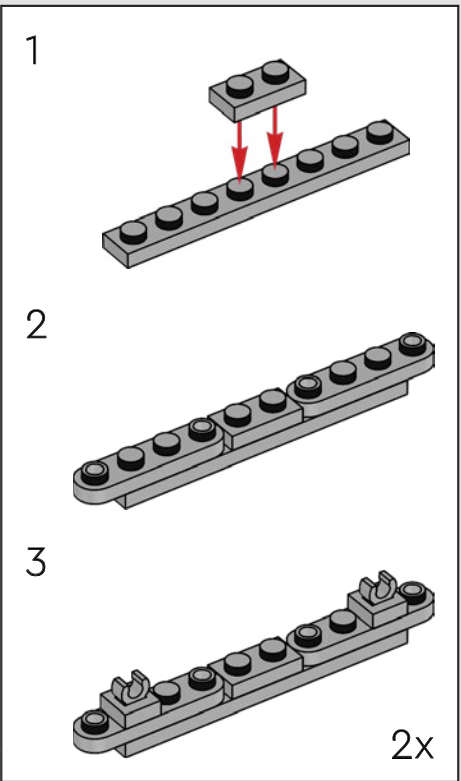

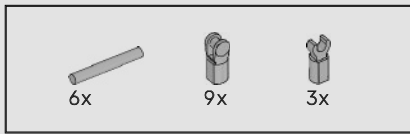

218

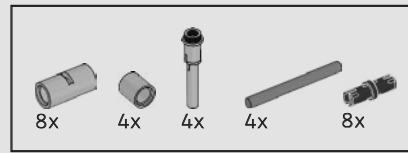
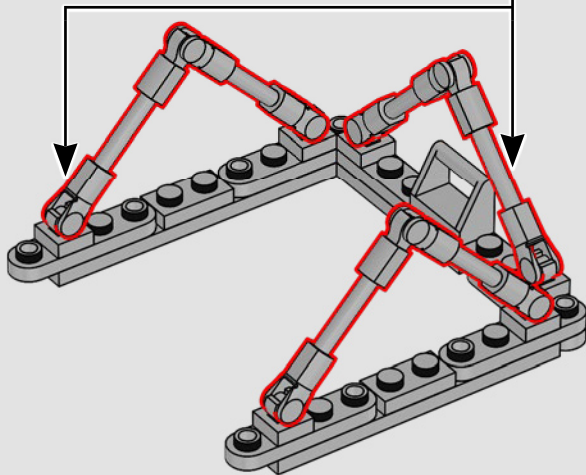
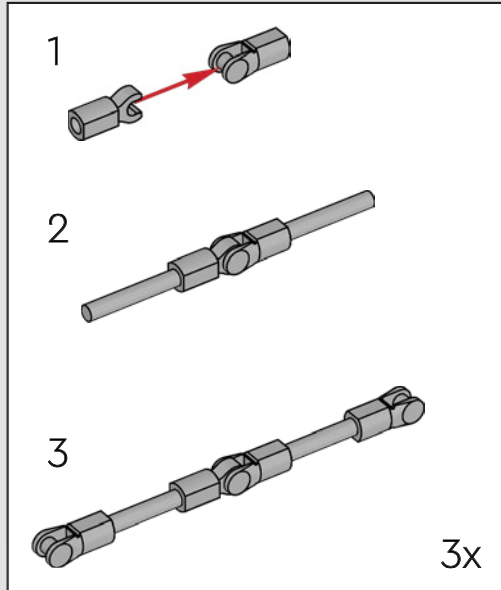

219

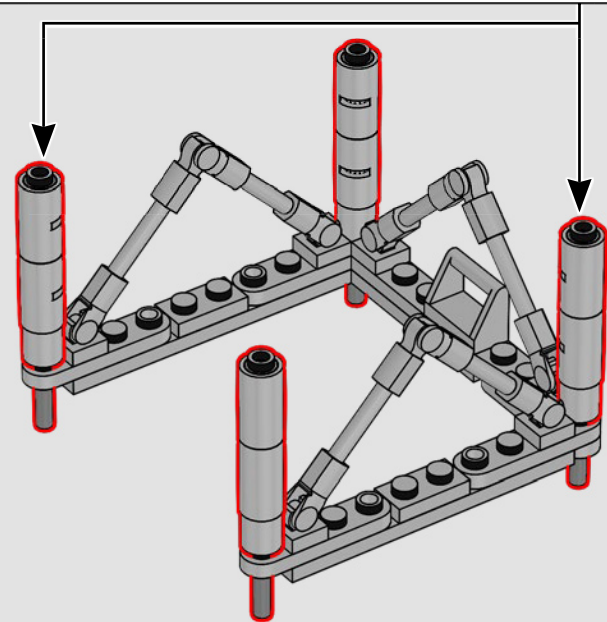
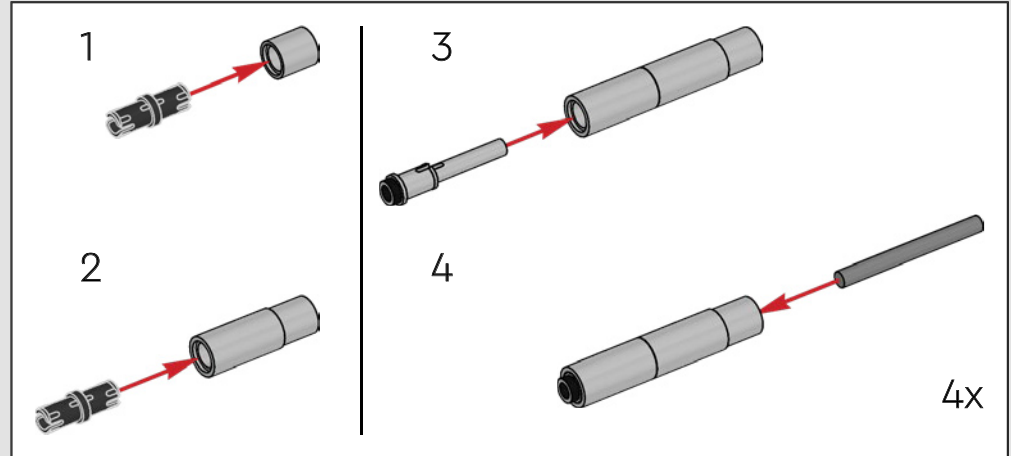

220

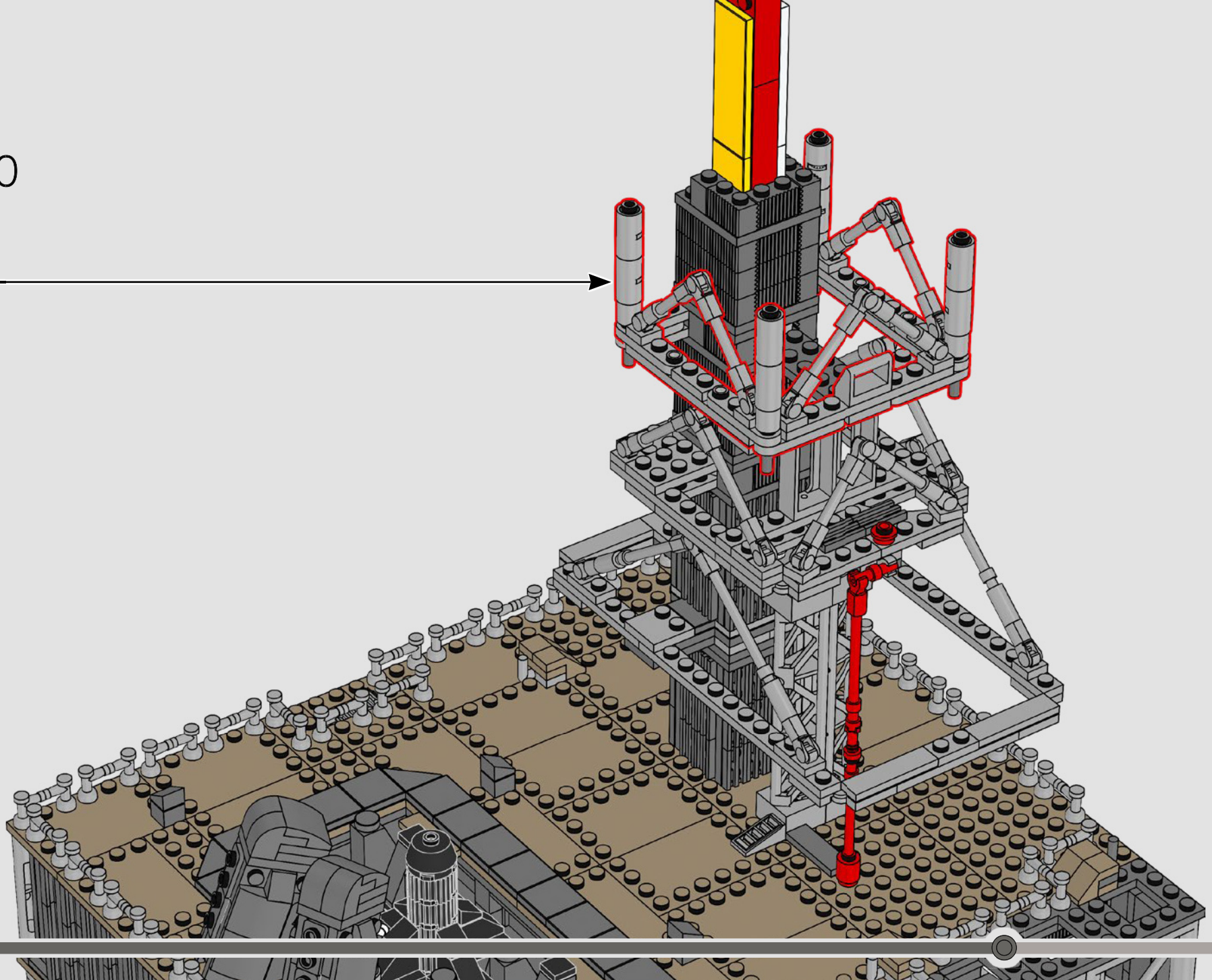

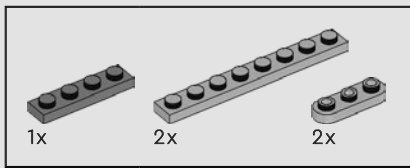

221

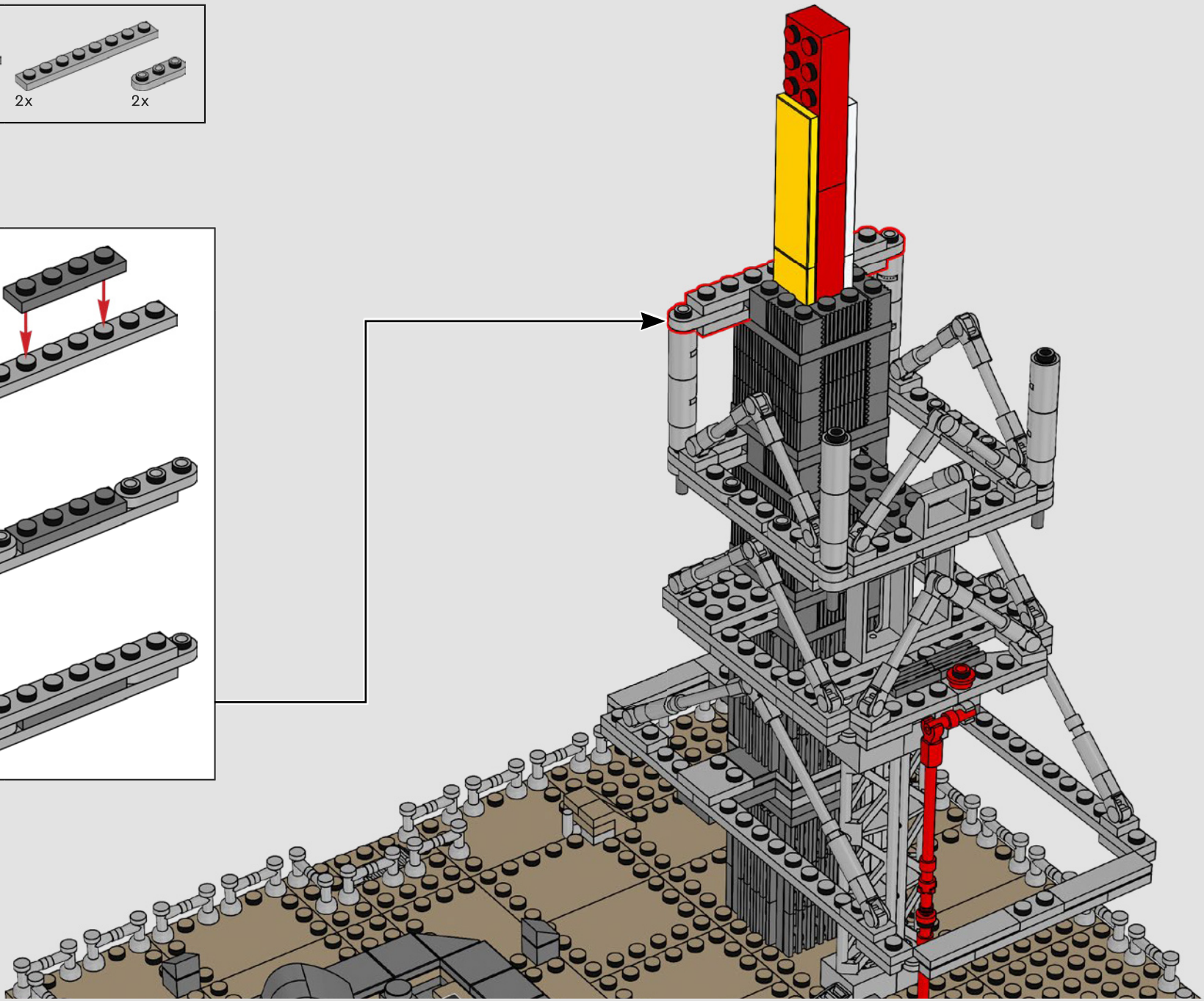
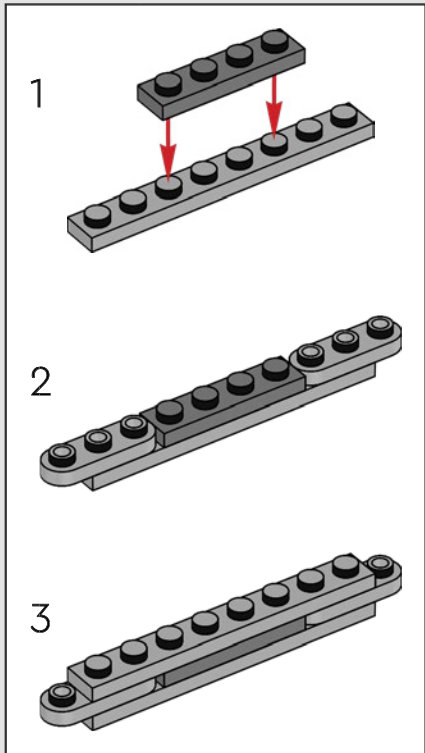



222

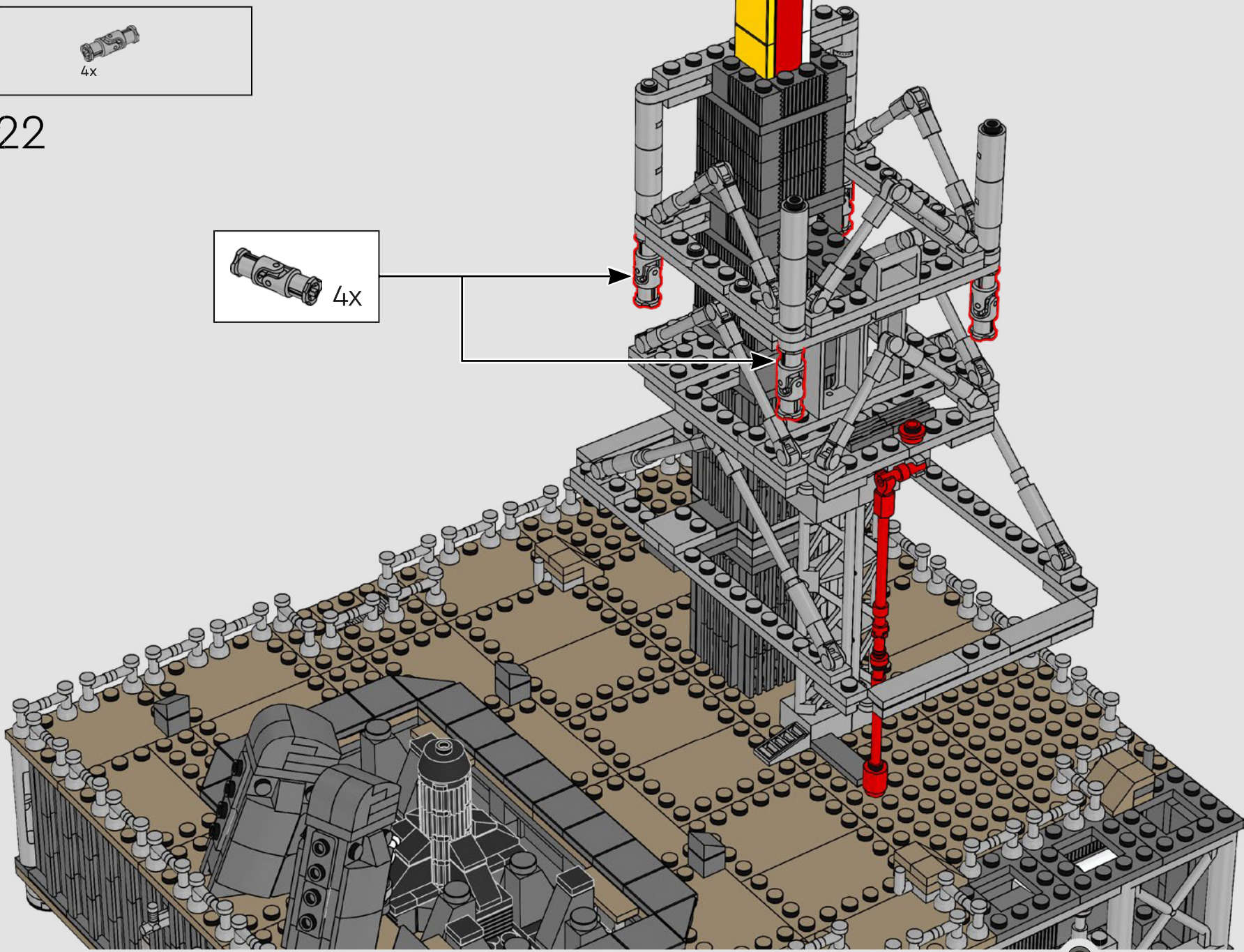
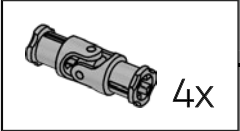

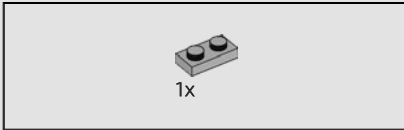
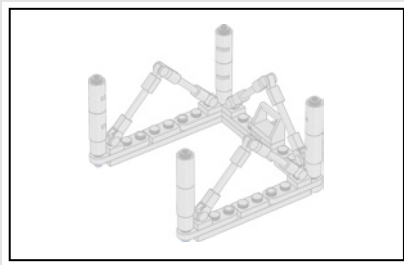

223

1x

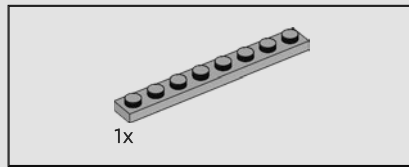

1x

224

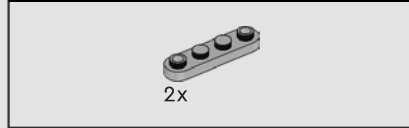
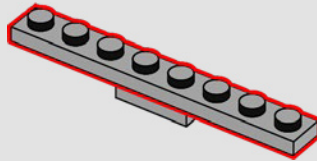

2x

225

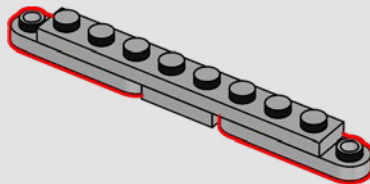

1x

1x

2x

226

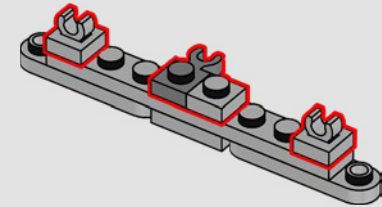

1x

227

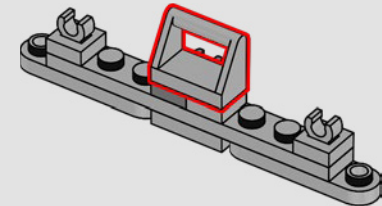

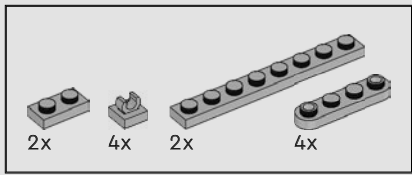

228

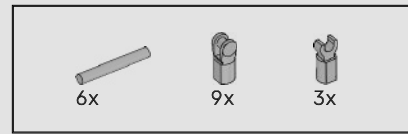
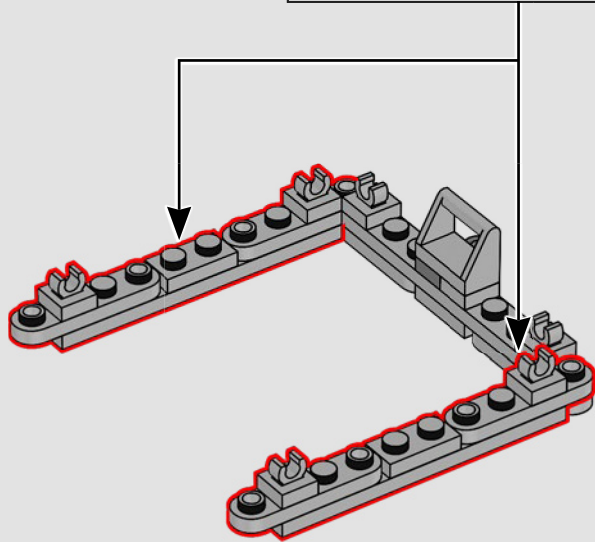
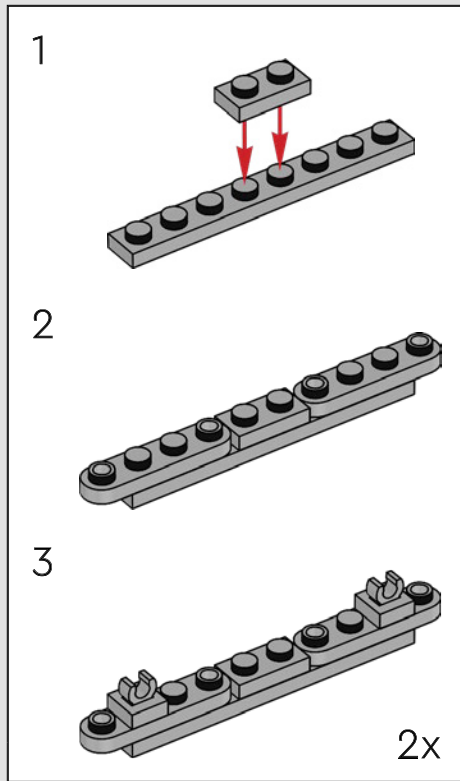

229

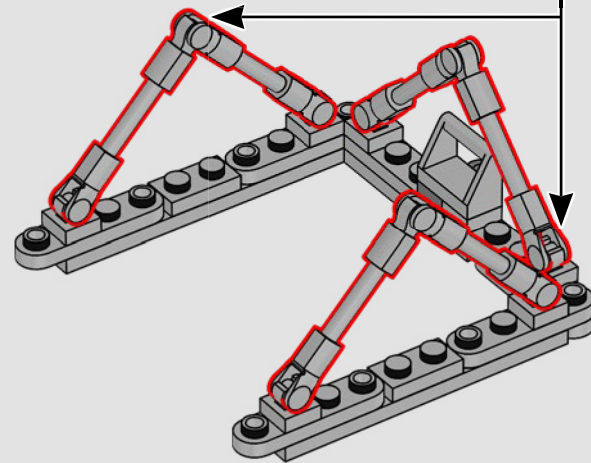
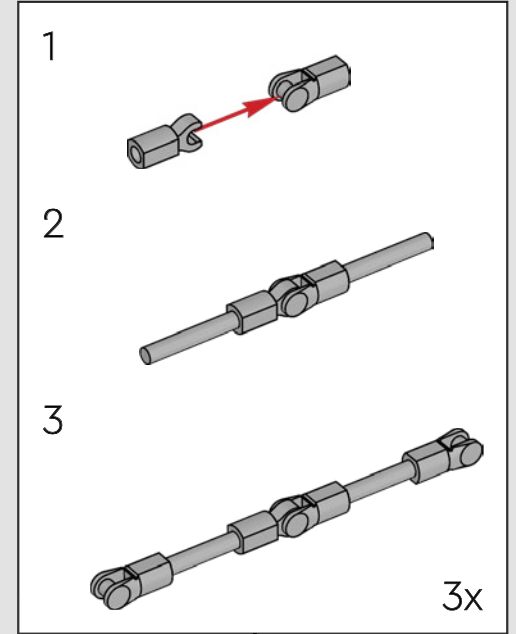

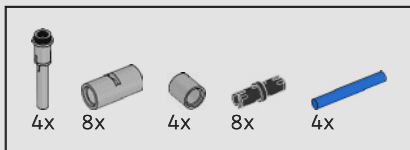

230

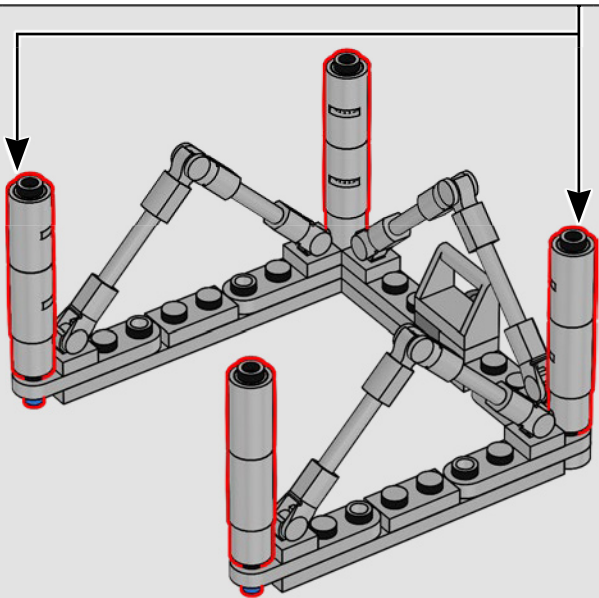
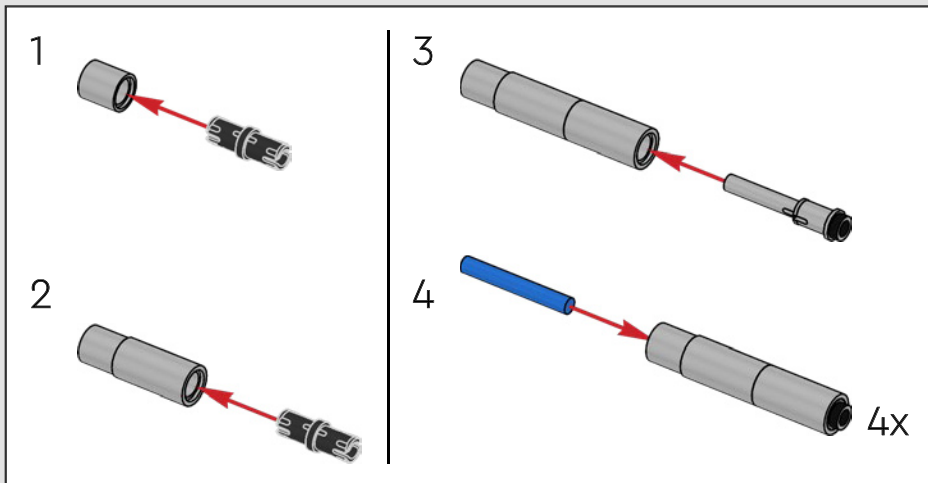

231

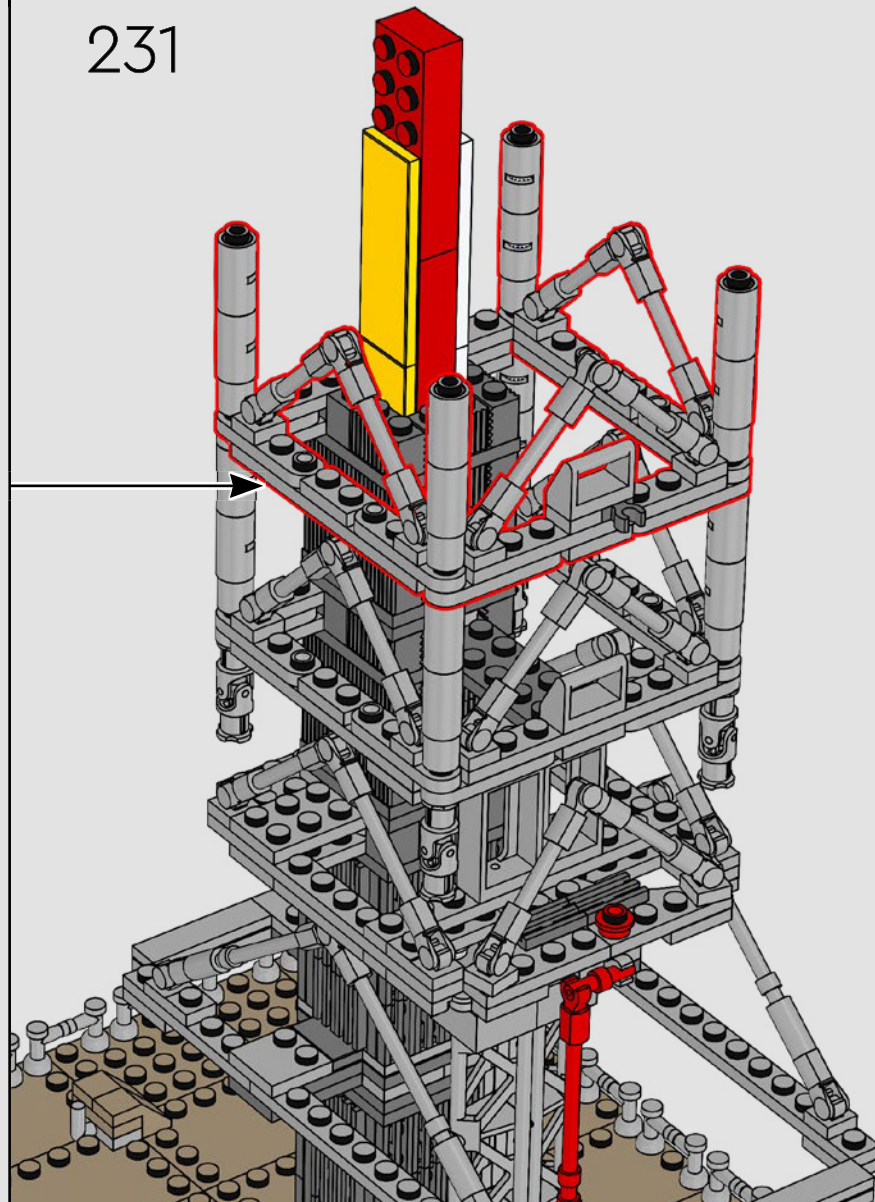

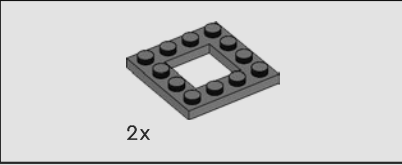
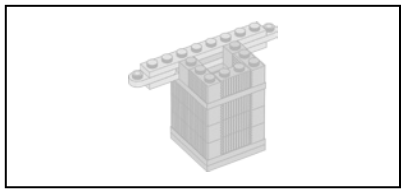

232

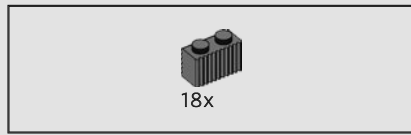
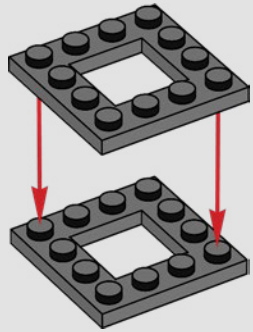

233

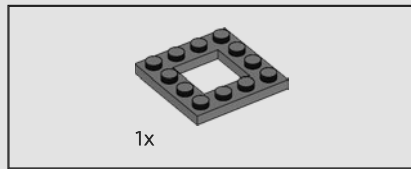
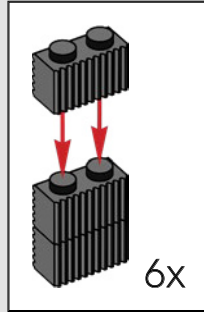

234

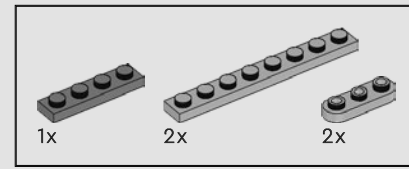
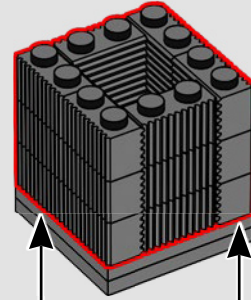
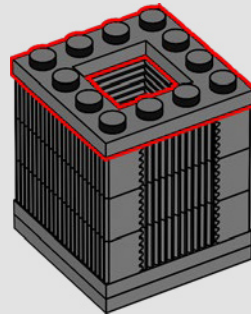

235

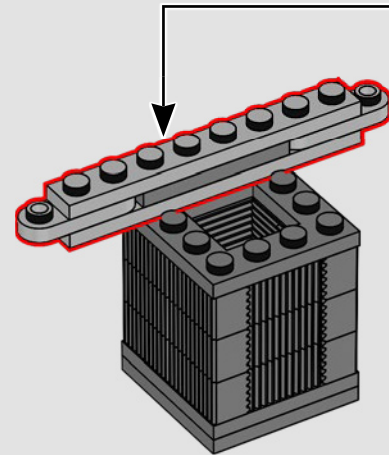
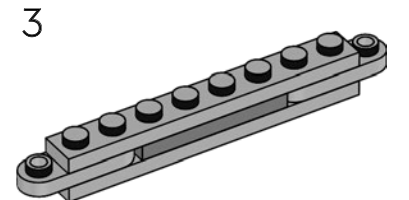
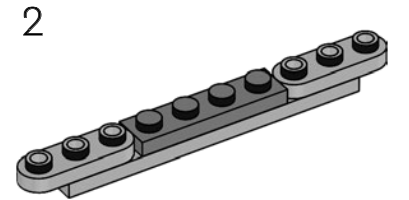
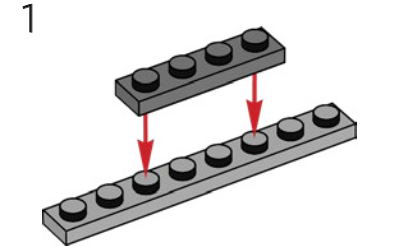

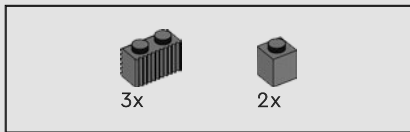

236

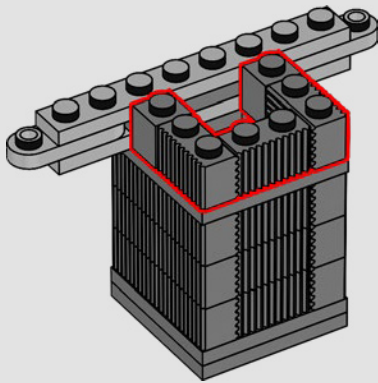

237

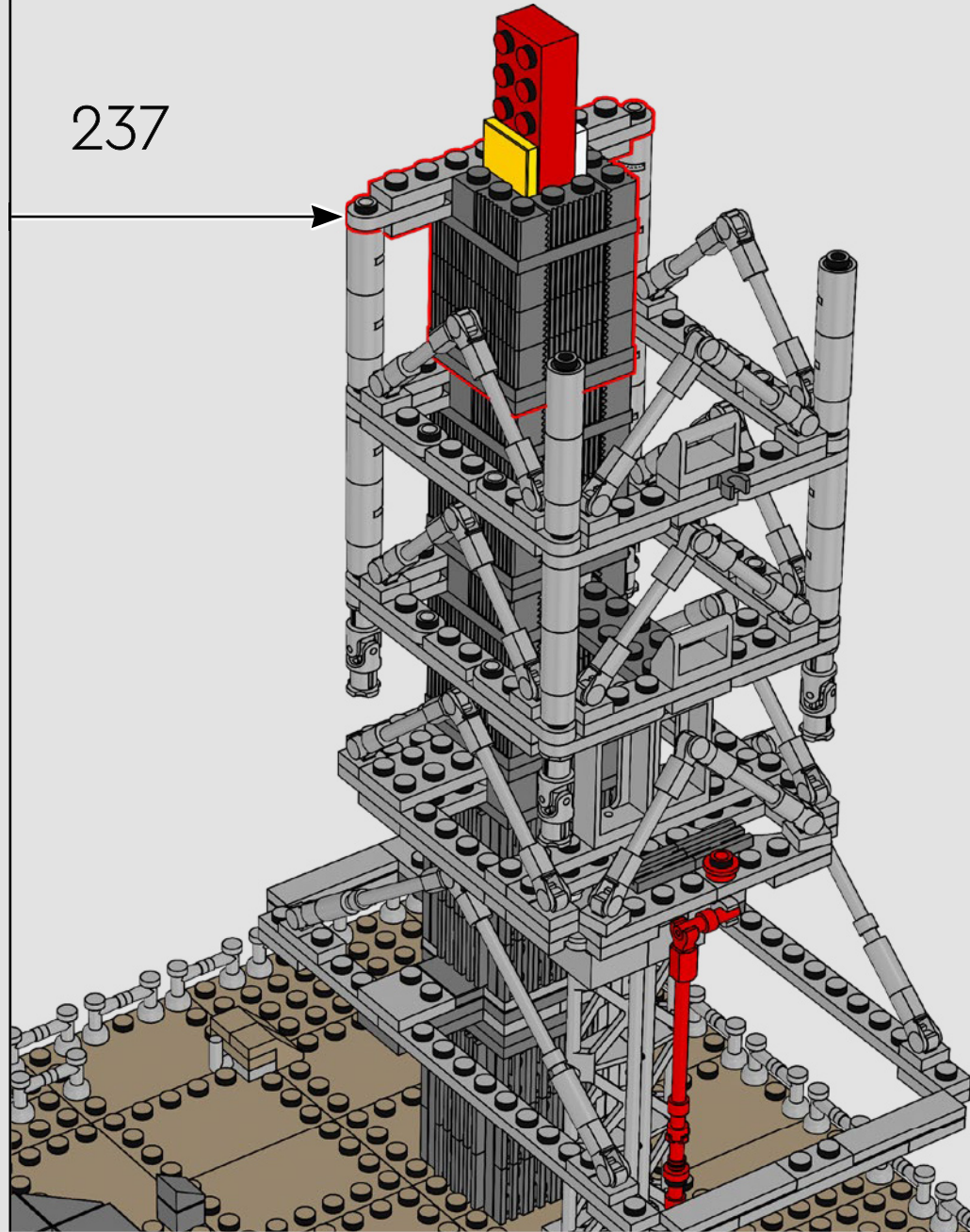

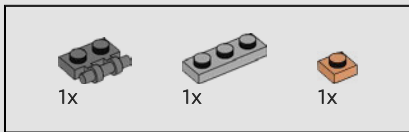

238

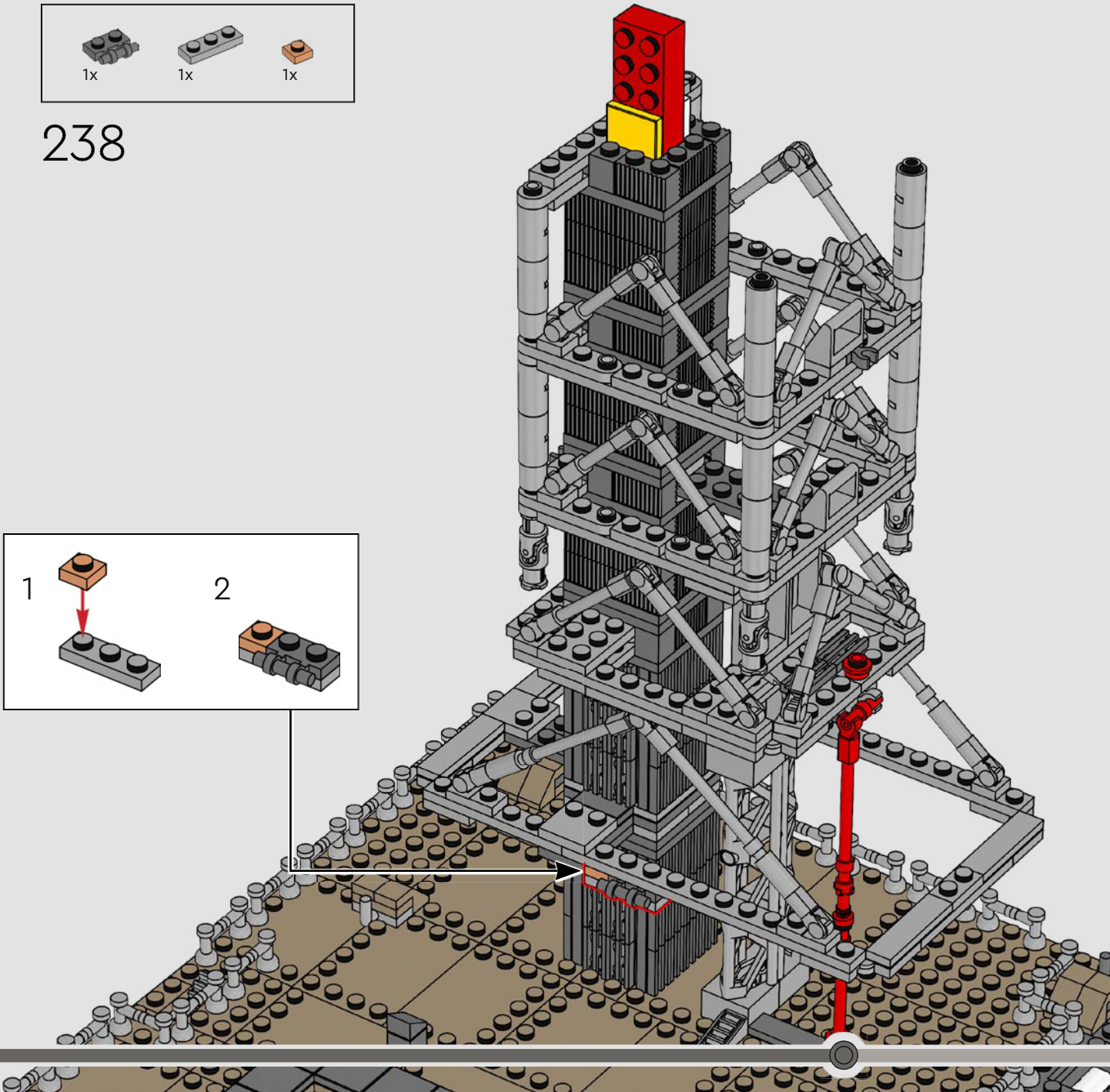
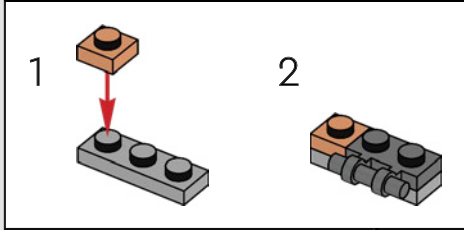

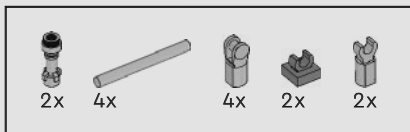

239

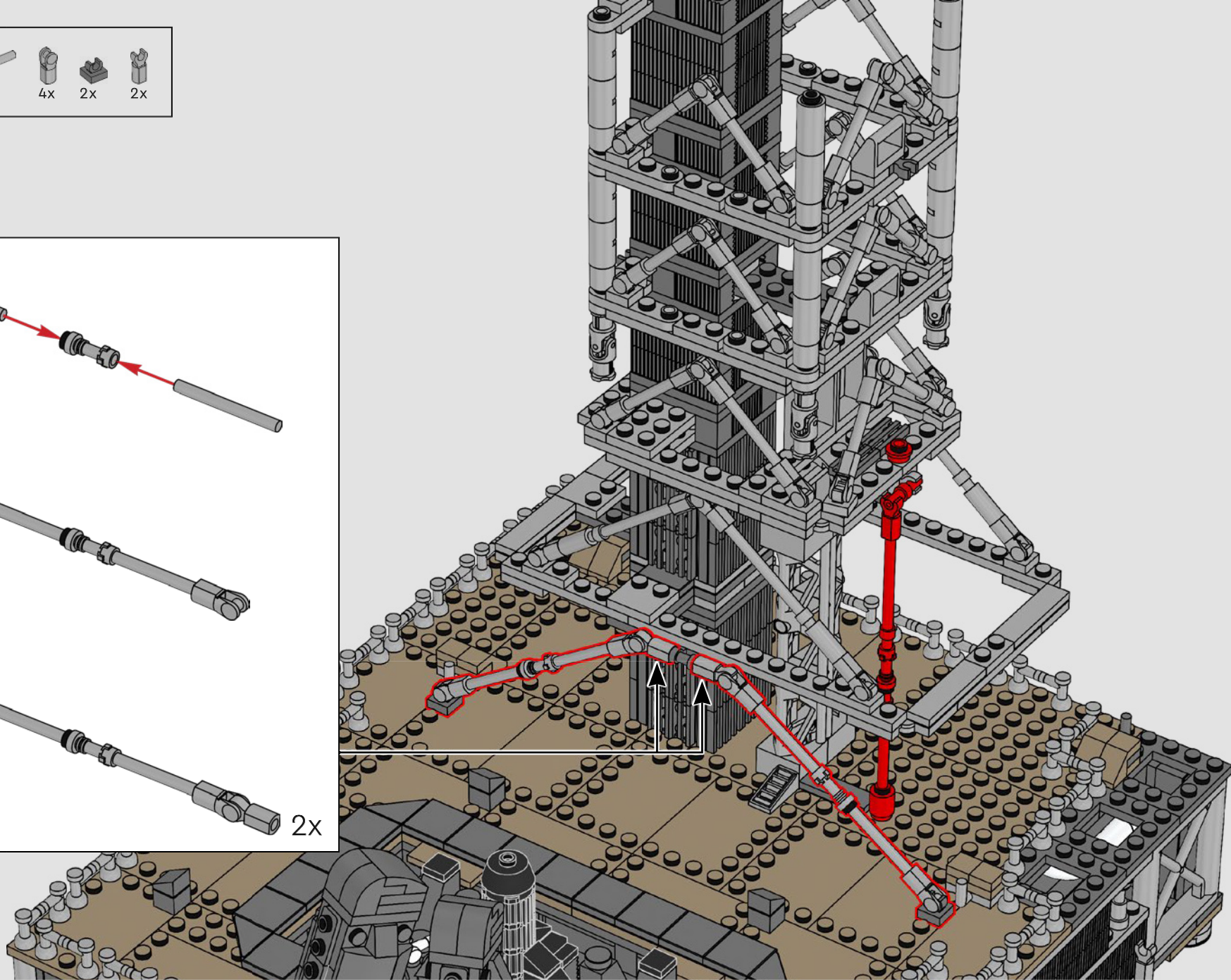
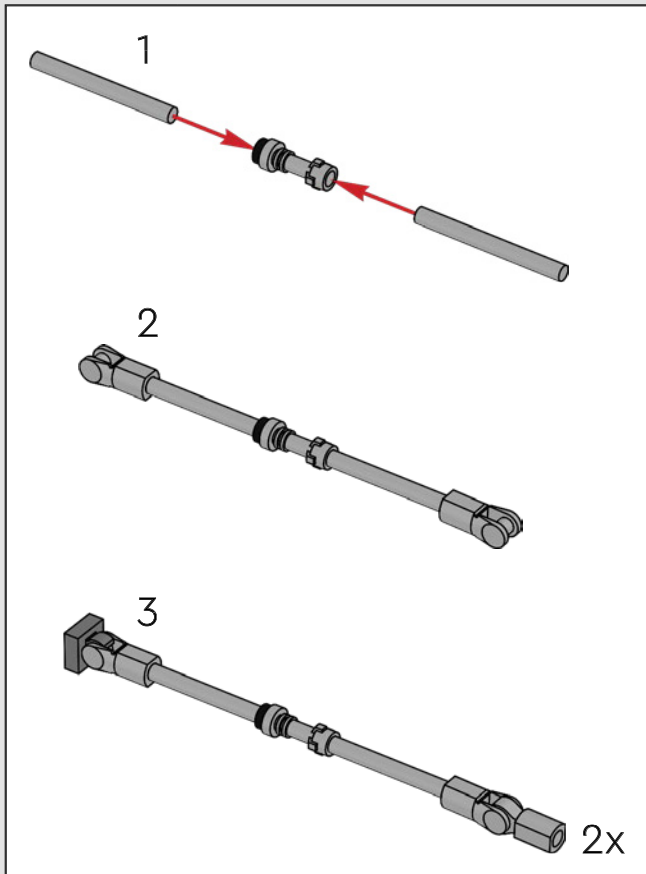

240

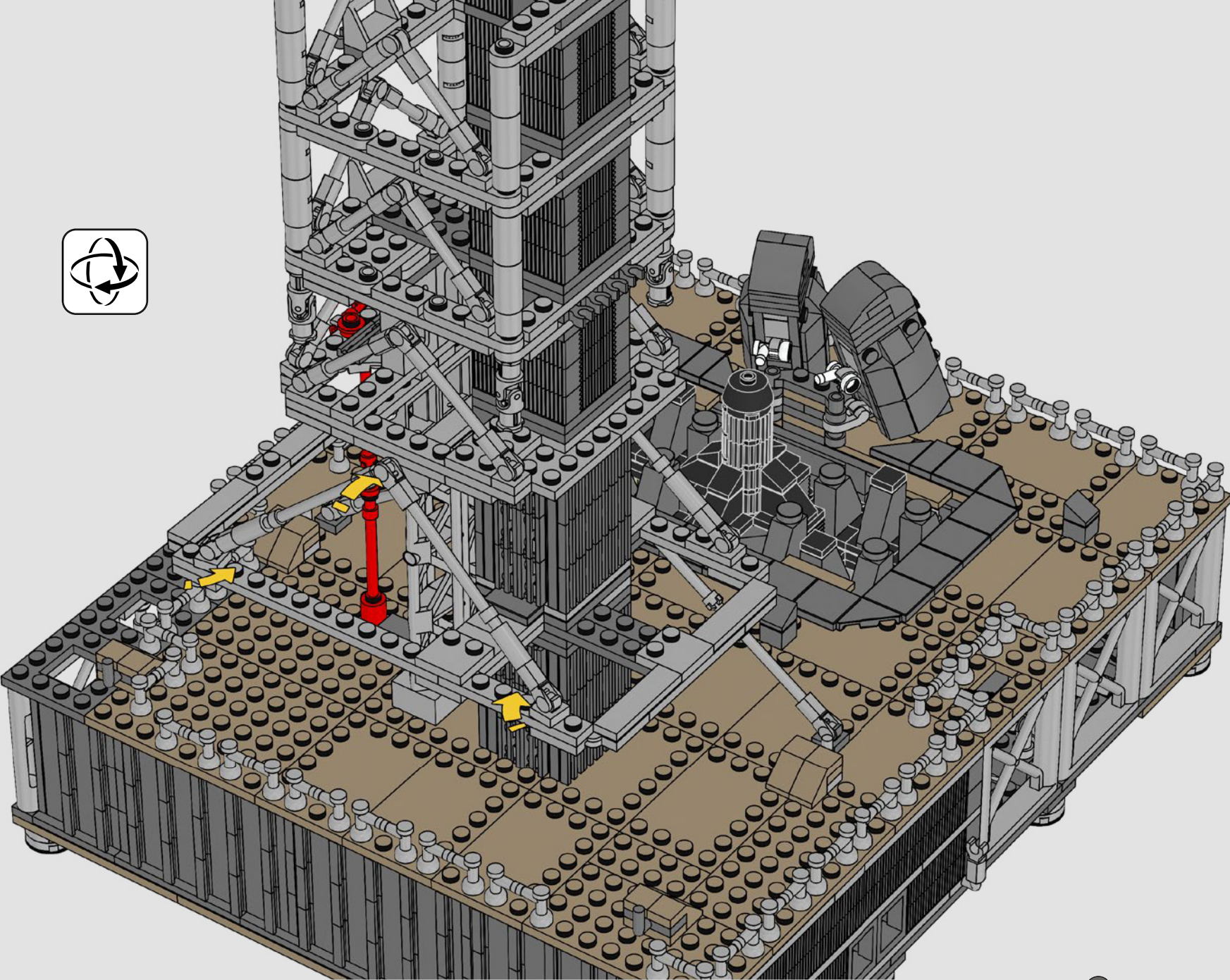

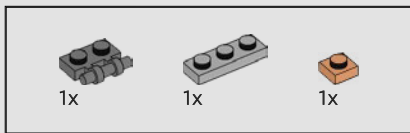

241

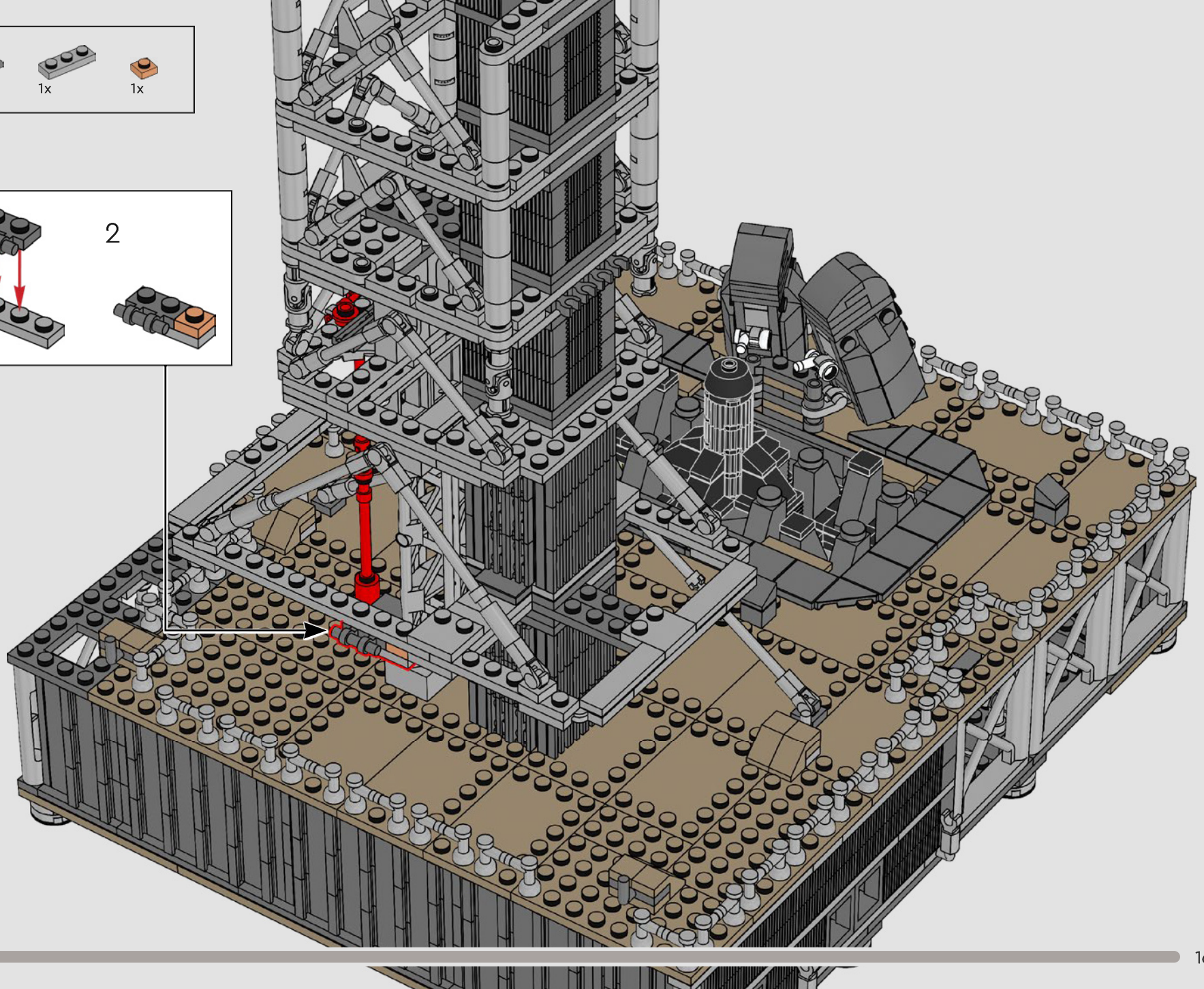
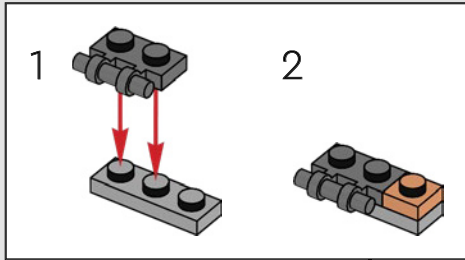

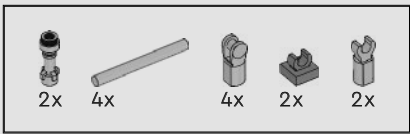

242

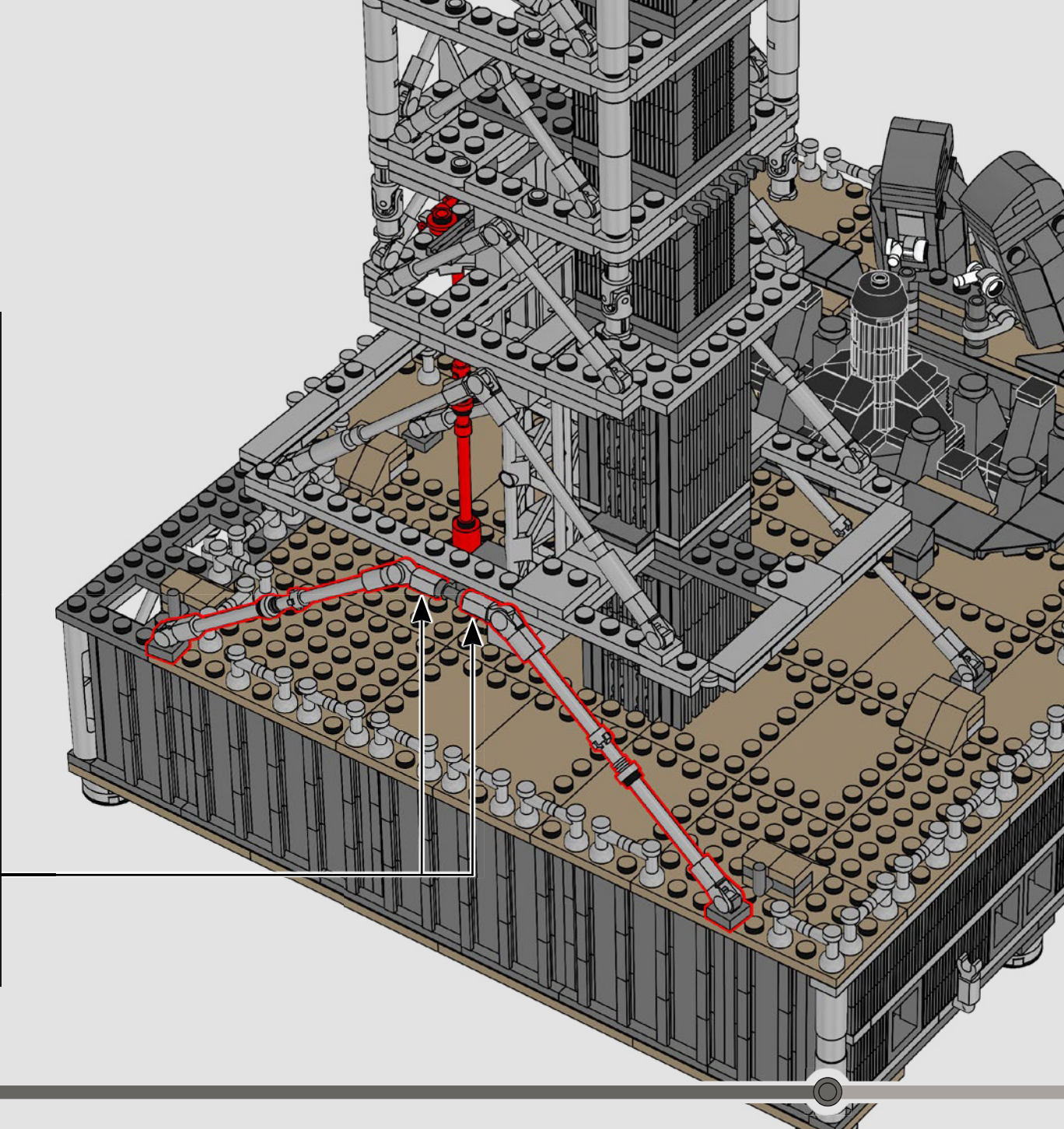
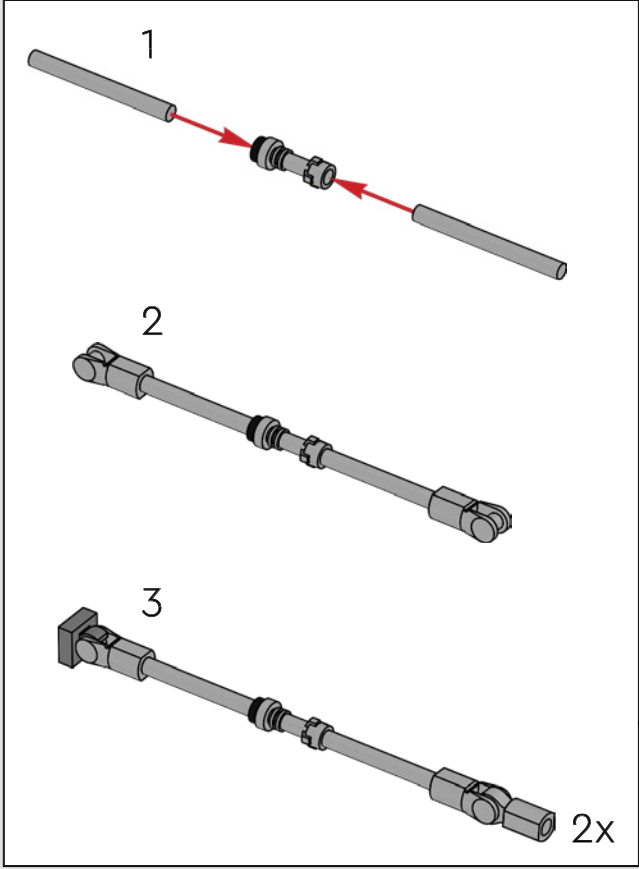

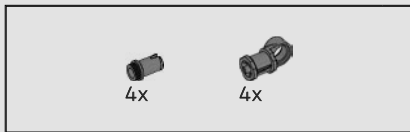

243

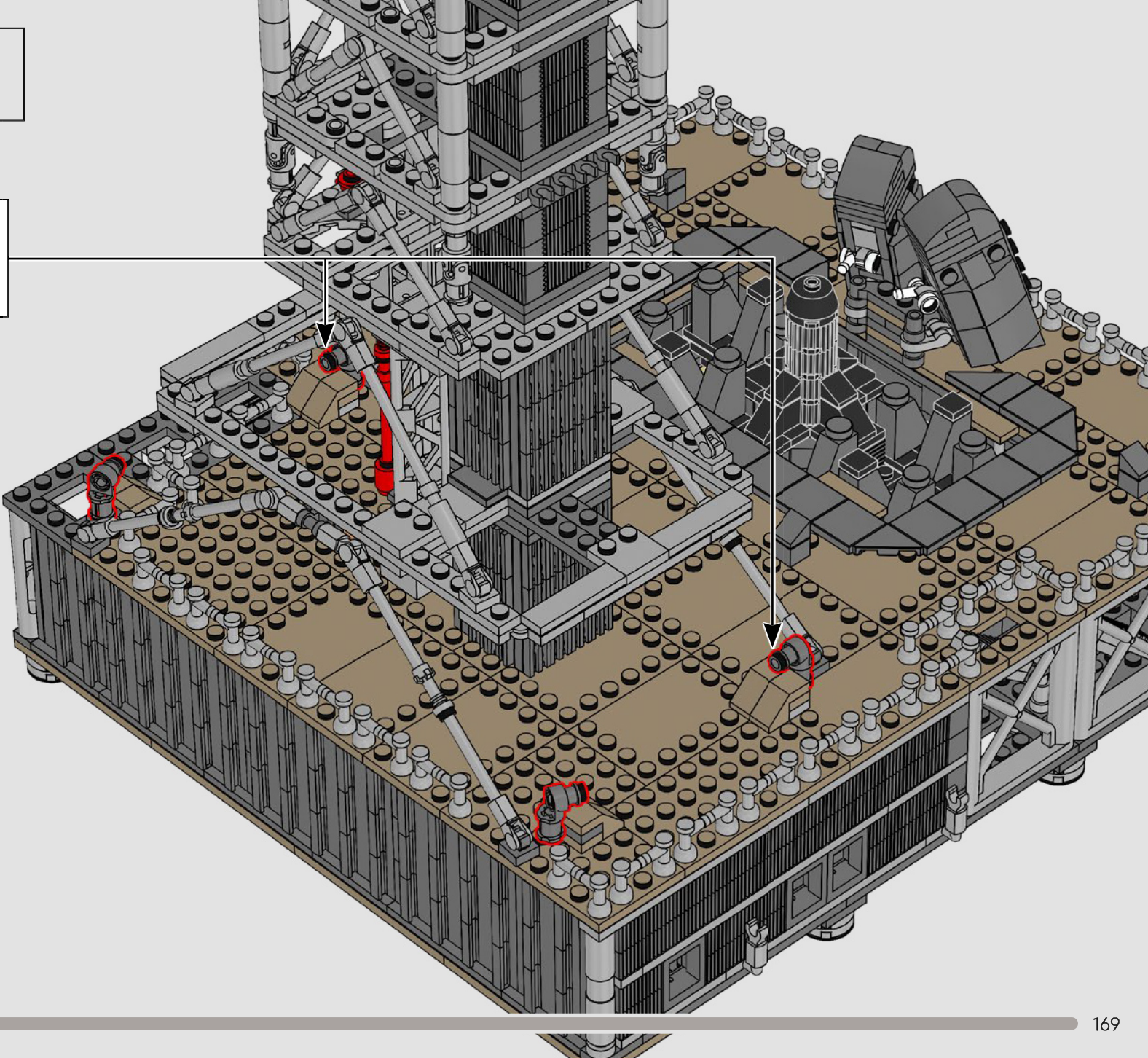
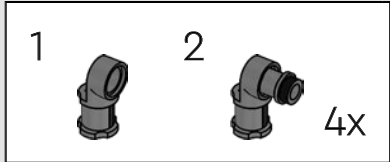

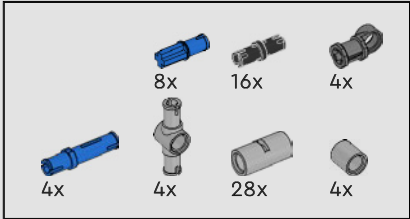
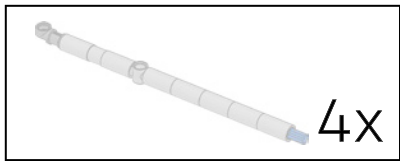

244

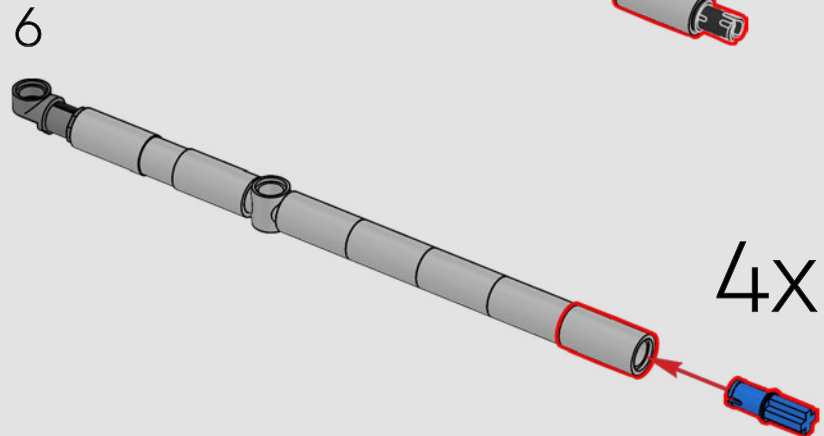
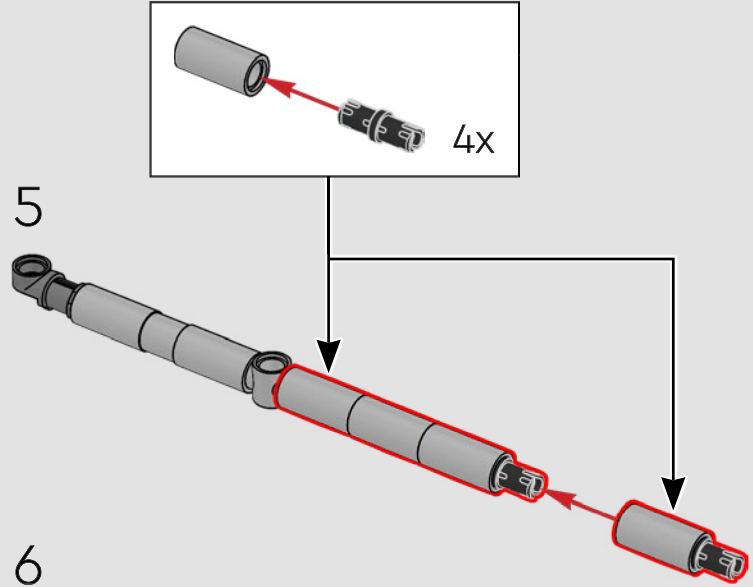
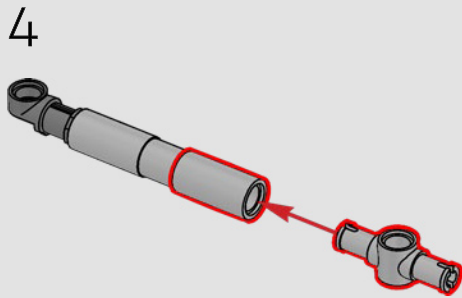
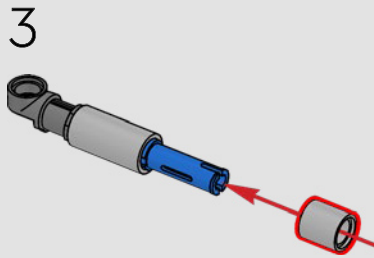
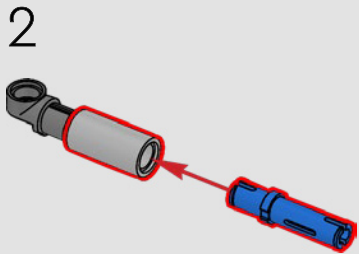
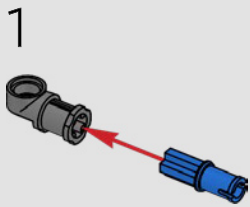

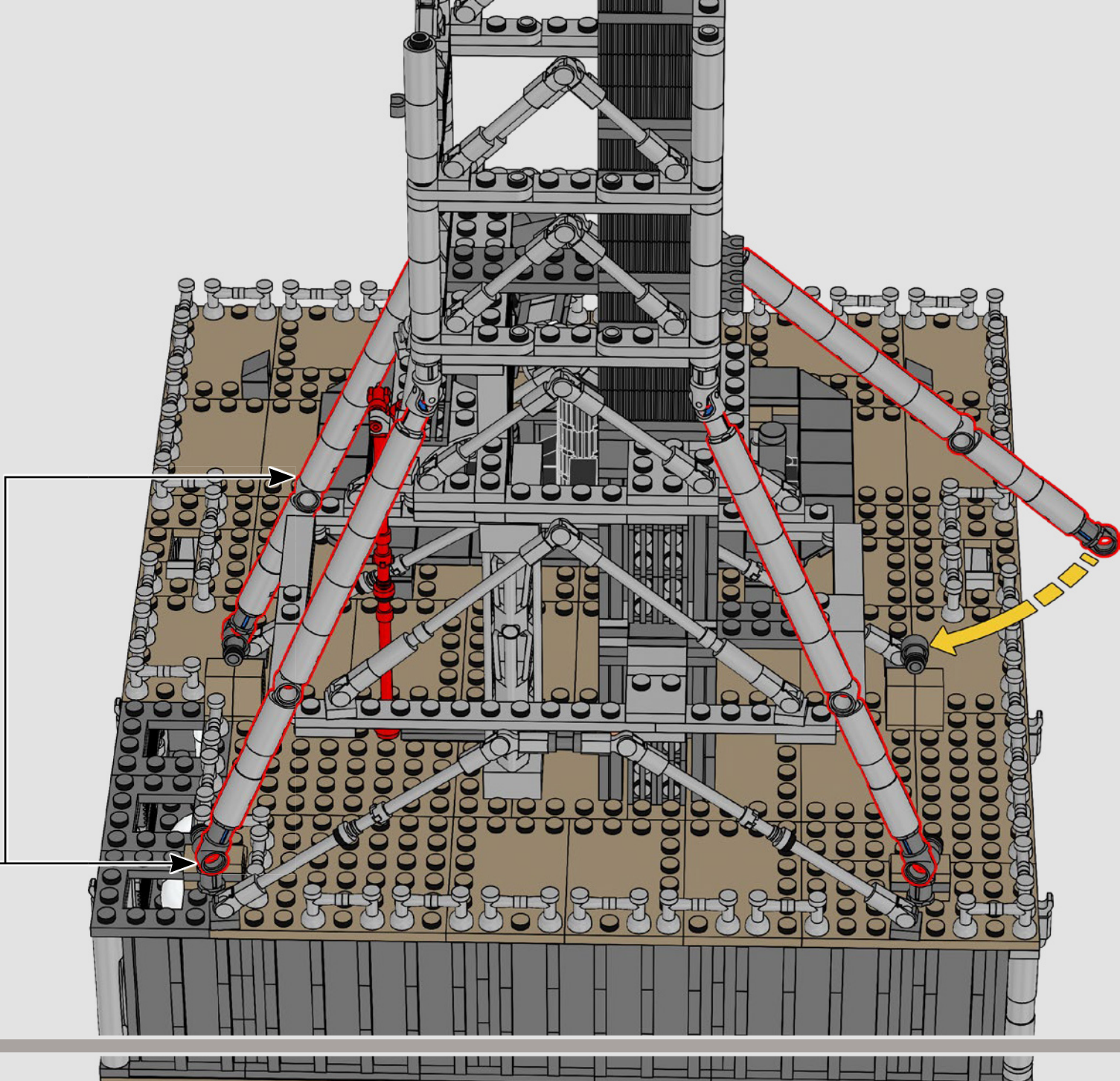

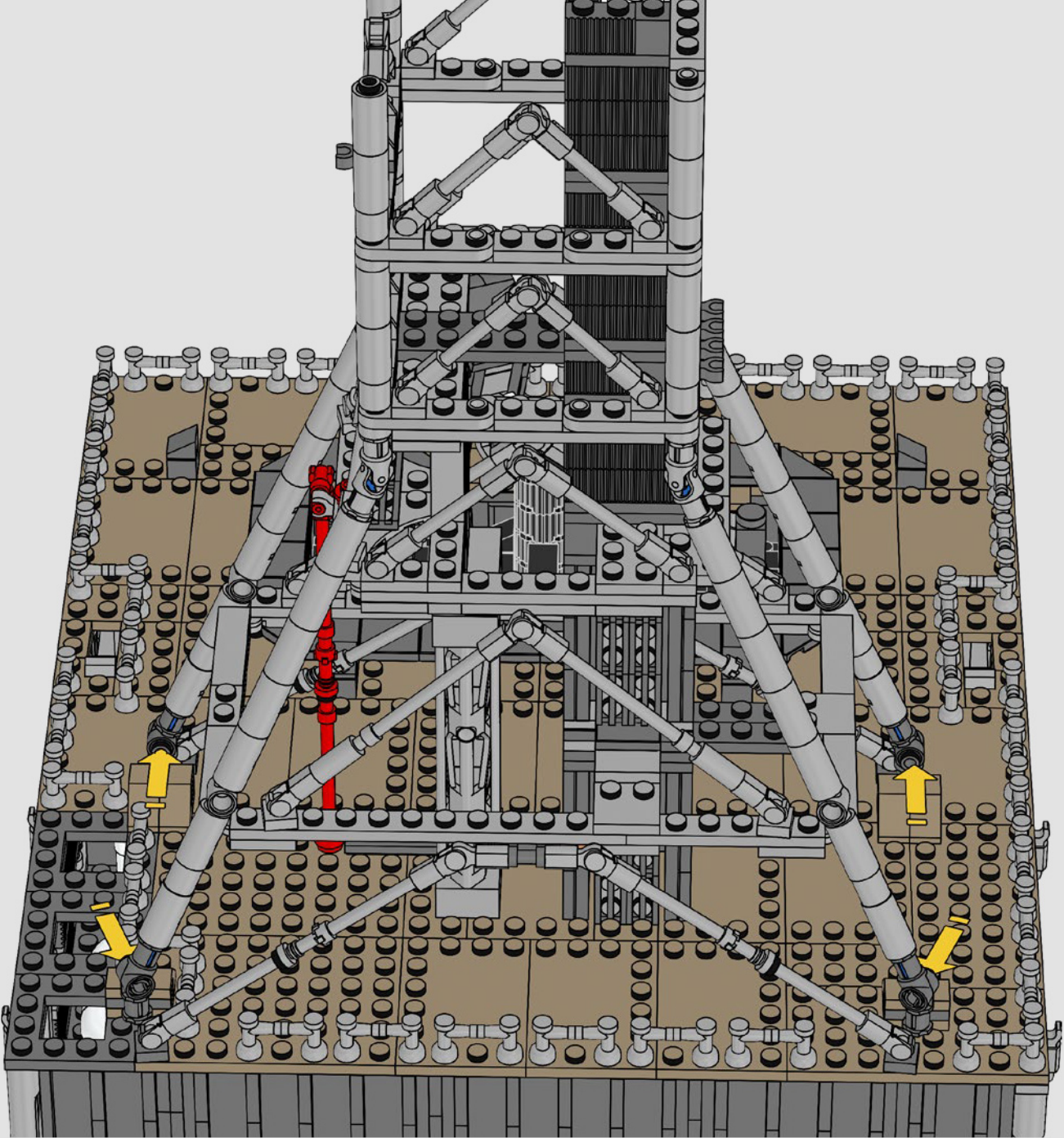

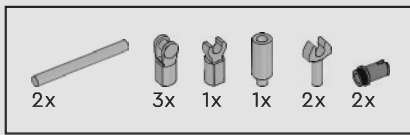

246

1

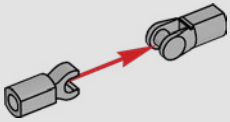

2

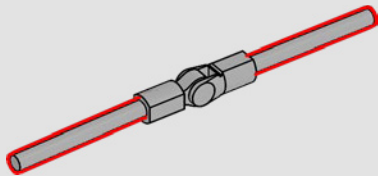

3

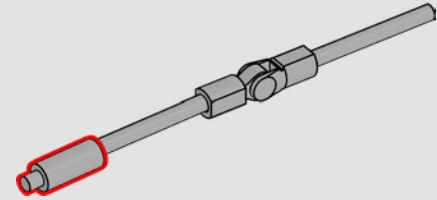

4

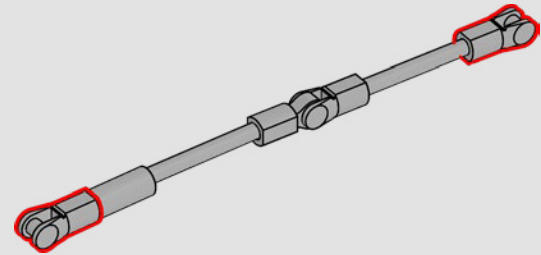

5

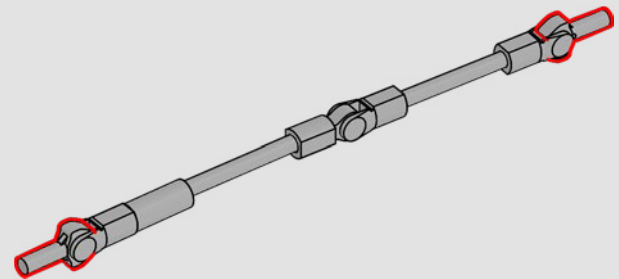

 2x

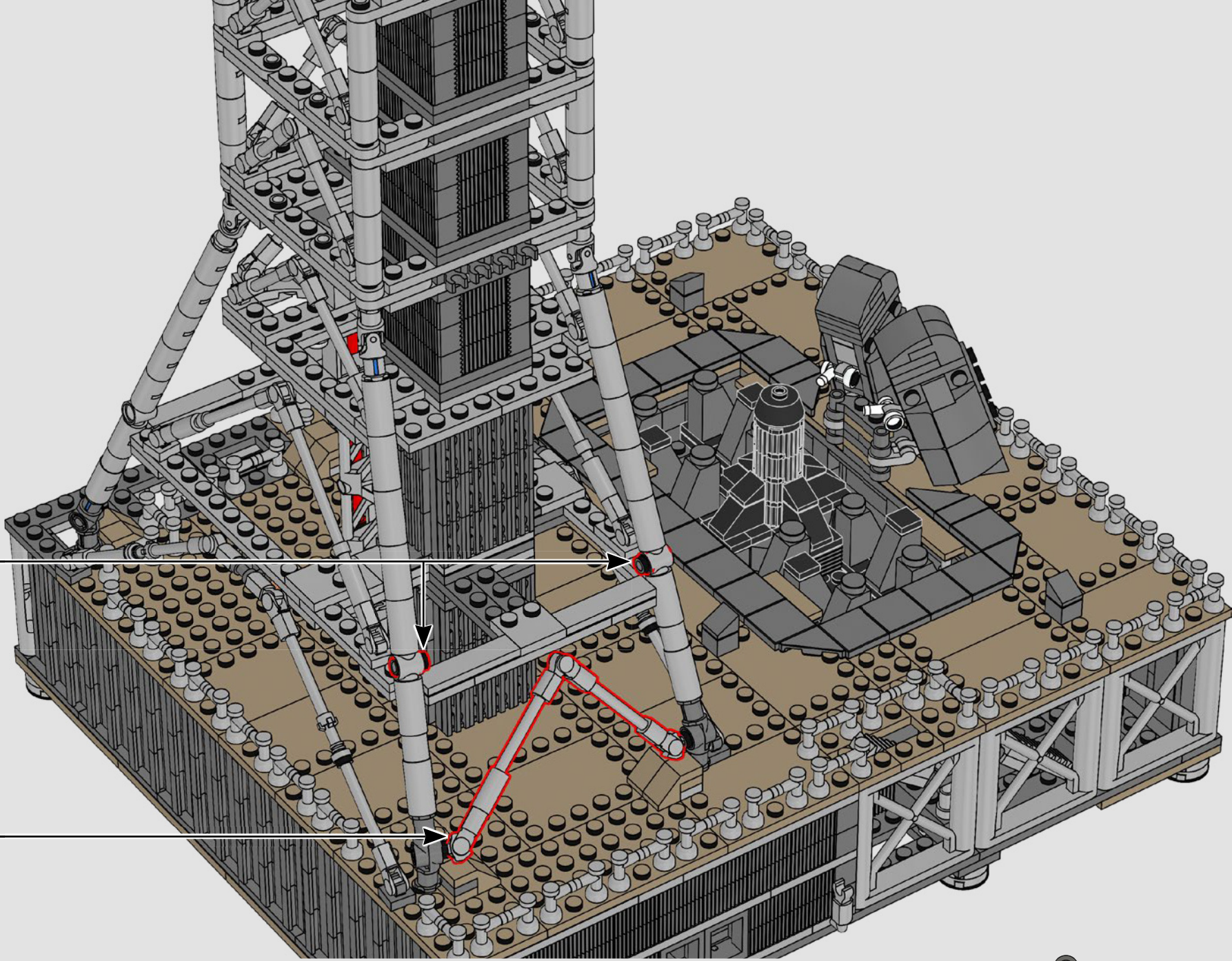

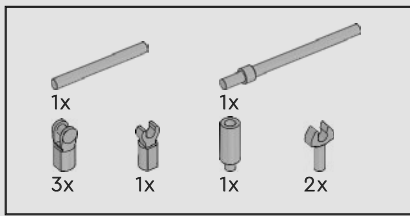

247

1

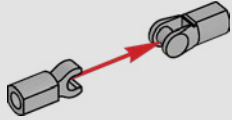

2

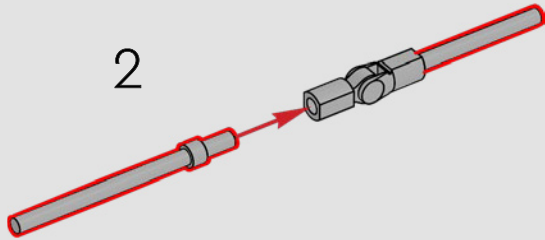

3

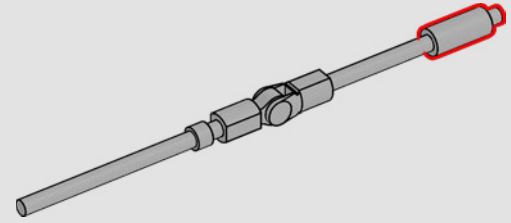

4

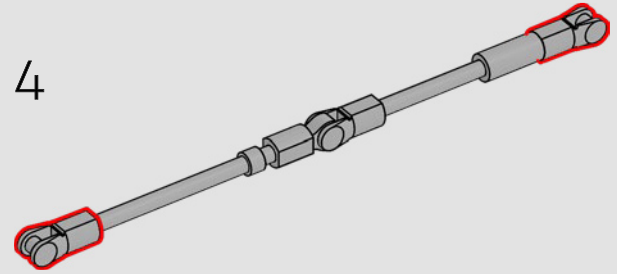

5

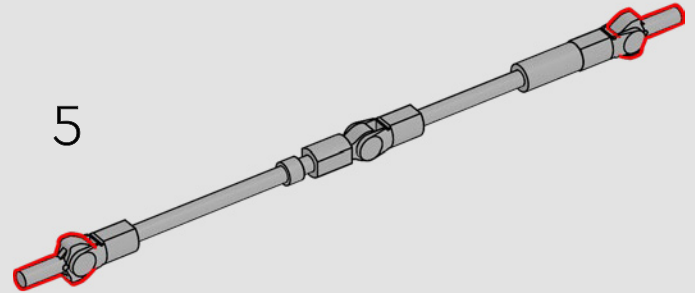

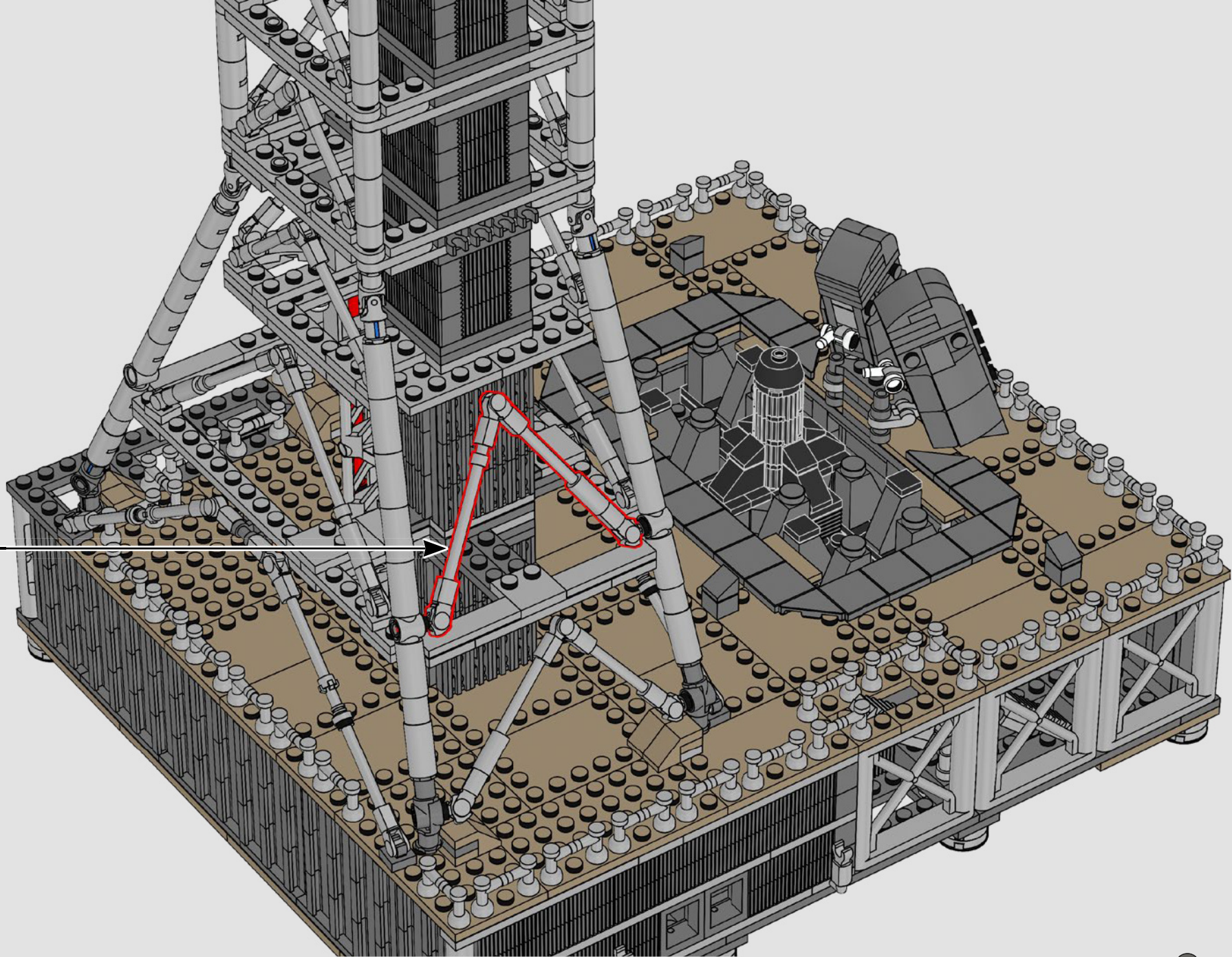

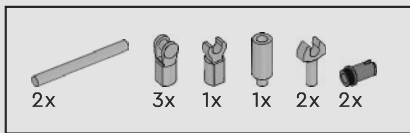

248

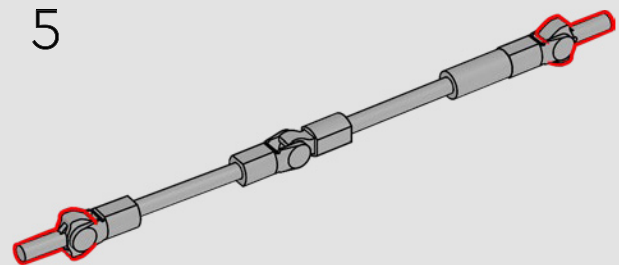
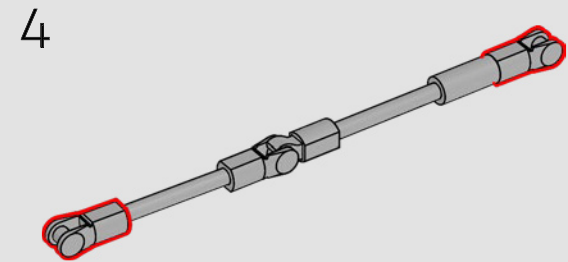
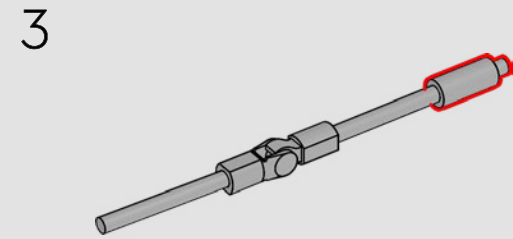
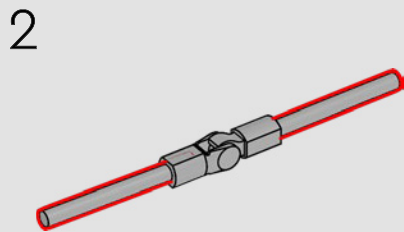
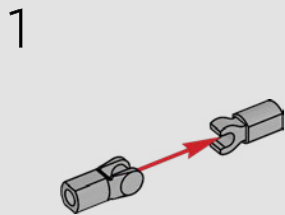

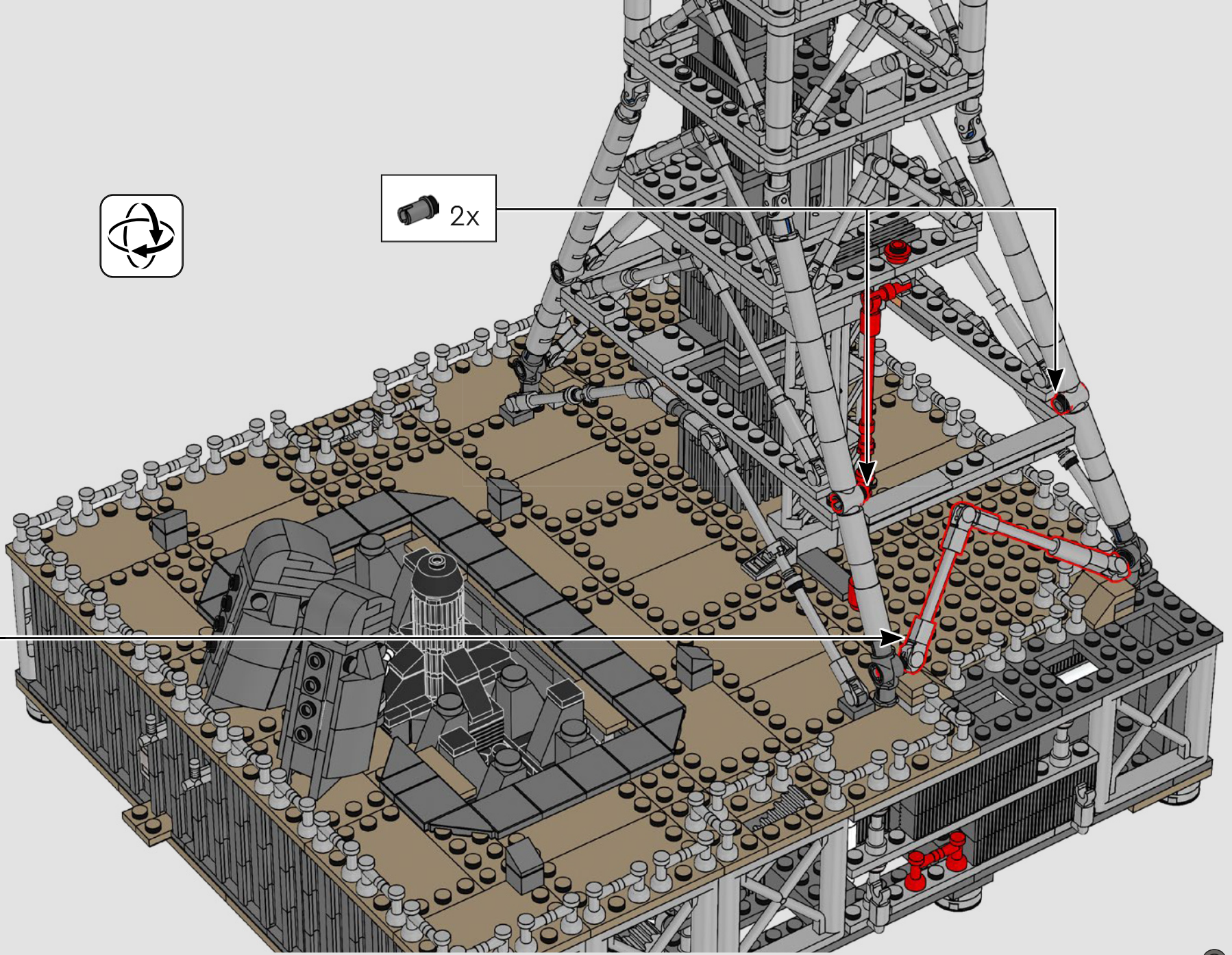

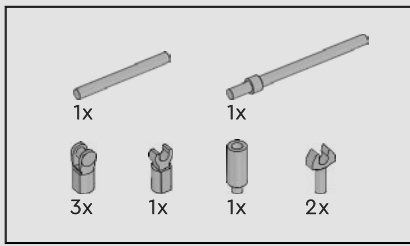

249

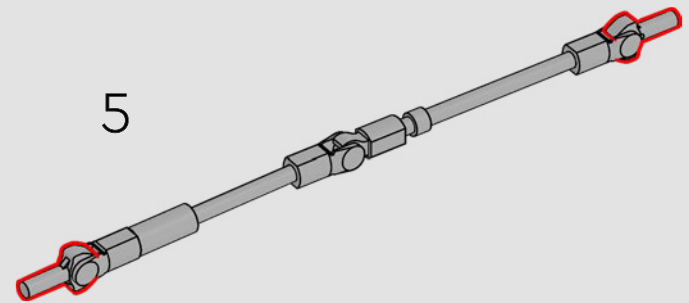
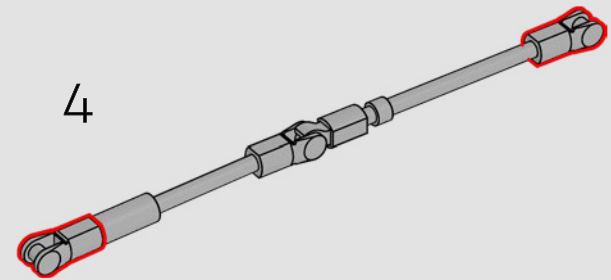
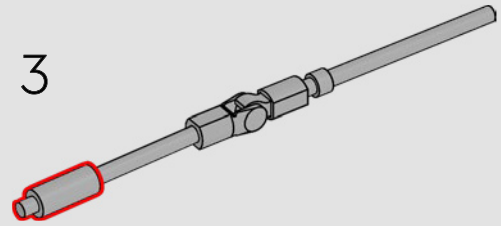
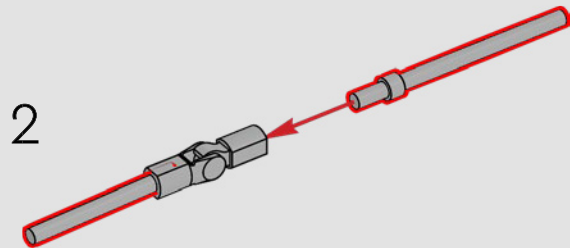
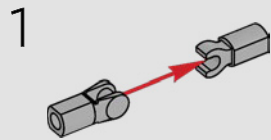

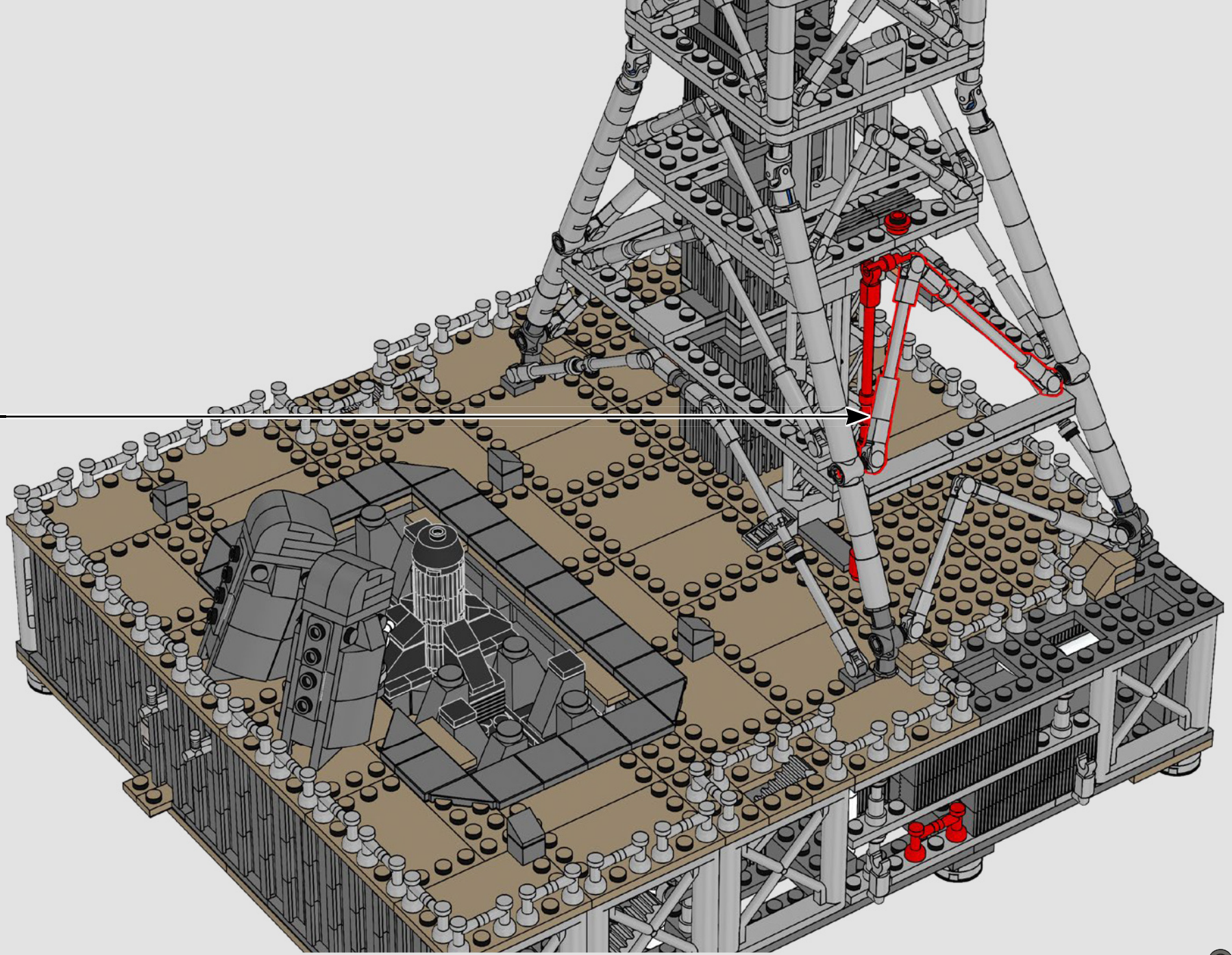

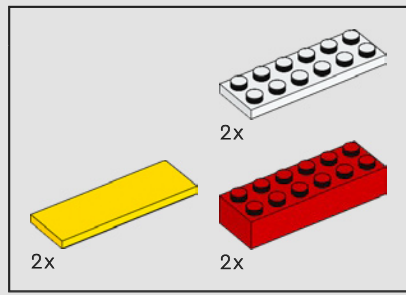

250

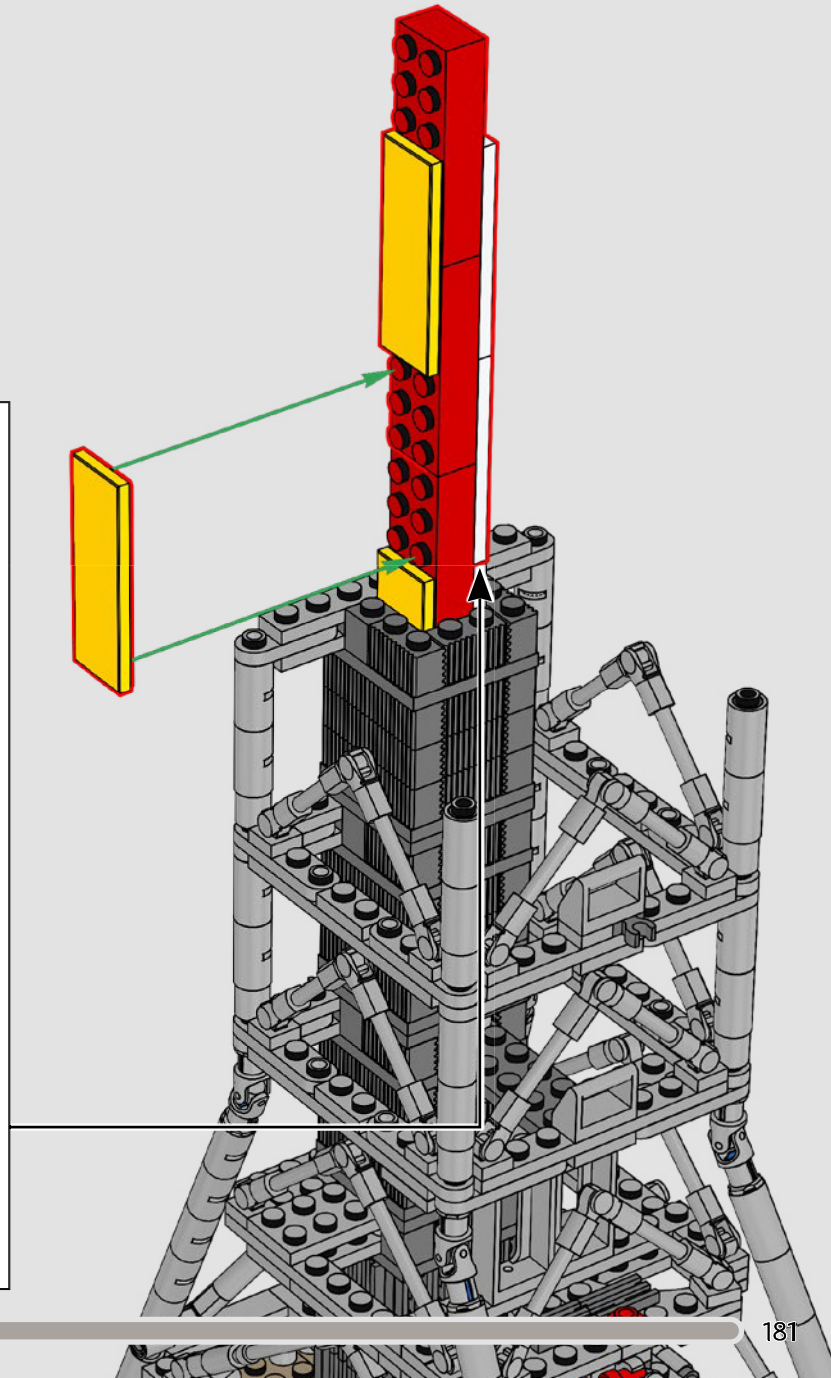
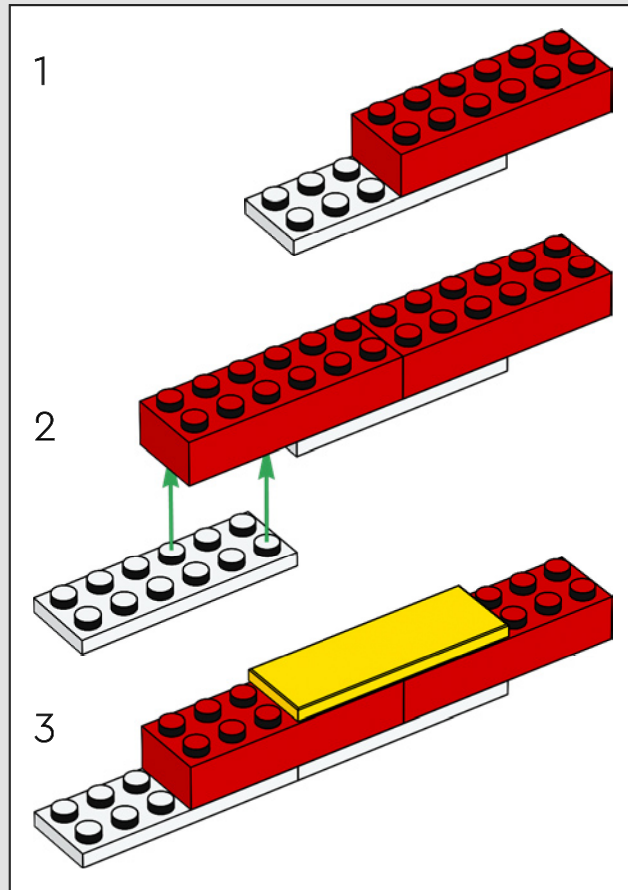

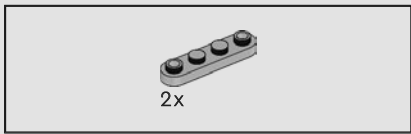
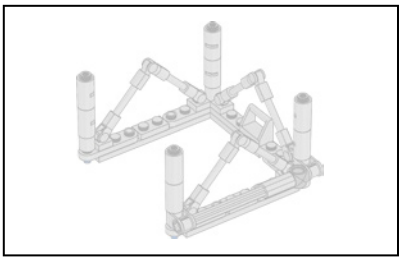

253

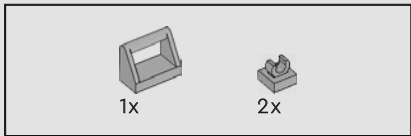
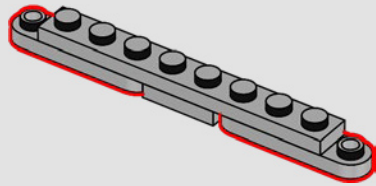

254

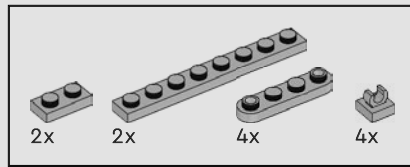
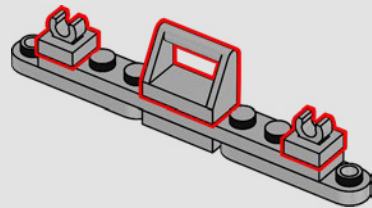

255

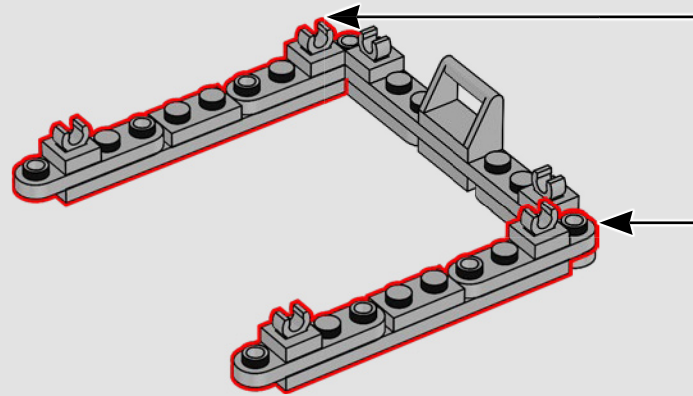
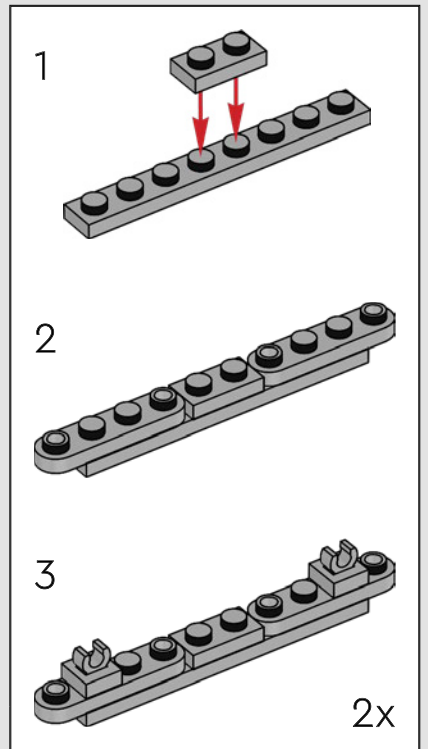

251

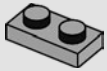
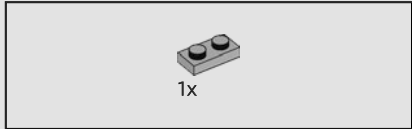

252

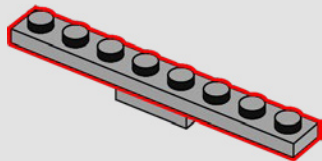
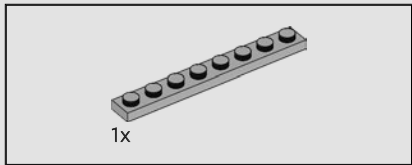

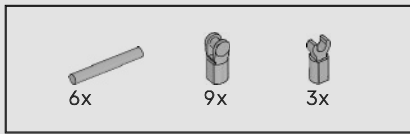

256

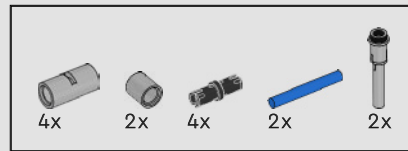
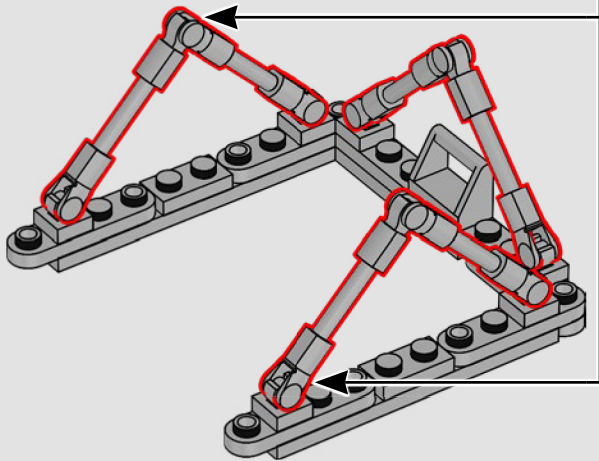
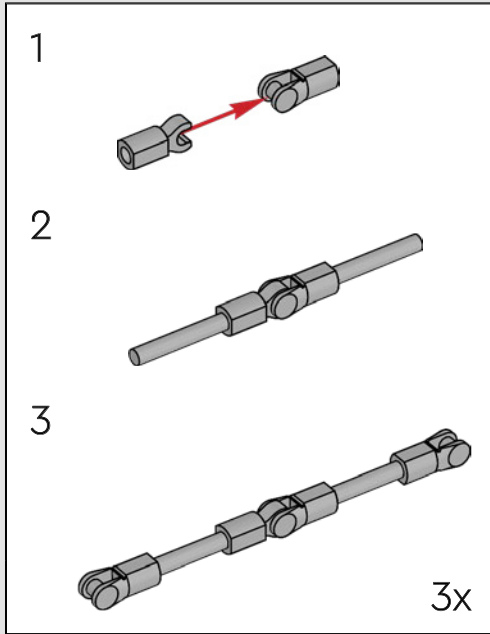

257

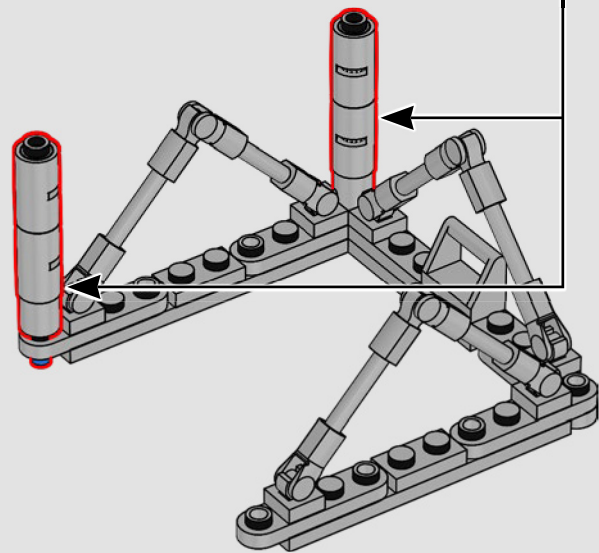
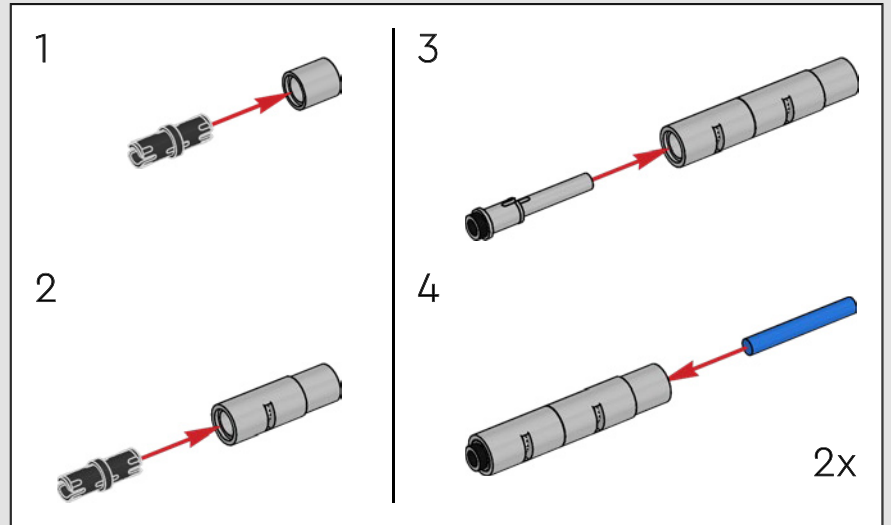

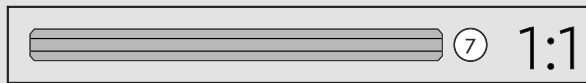
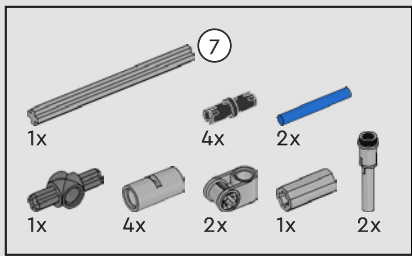

258

1

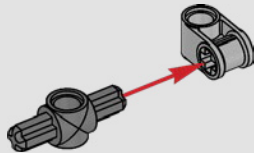

2

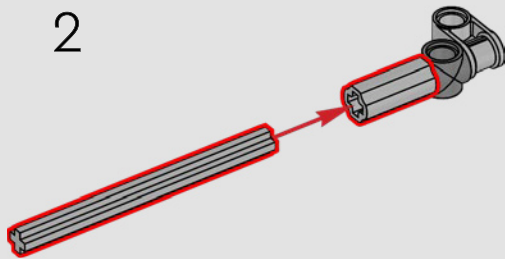

3

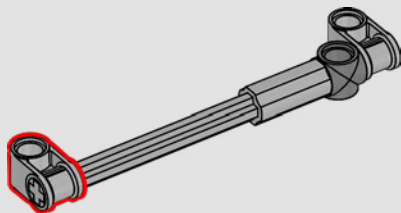

1

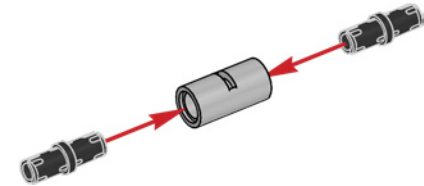

2

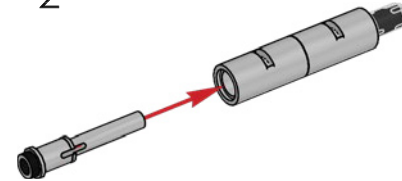

3

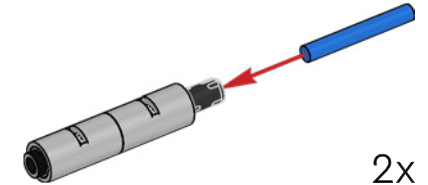

2x

4

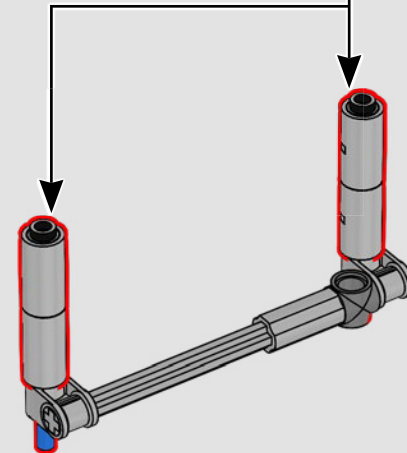

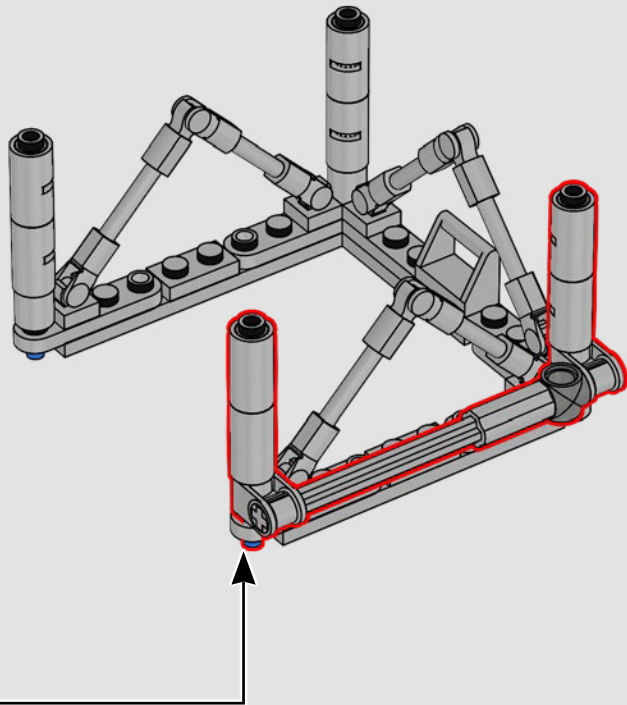

259

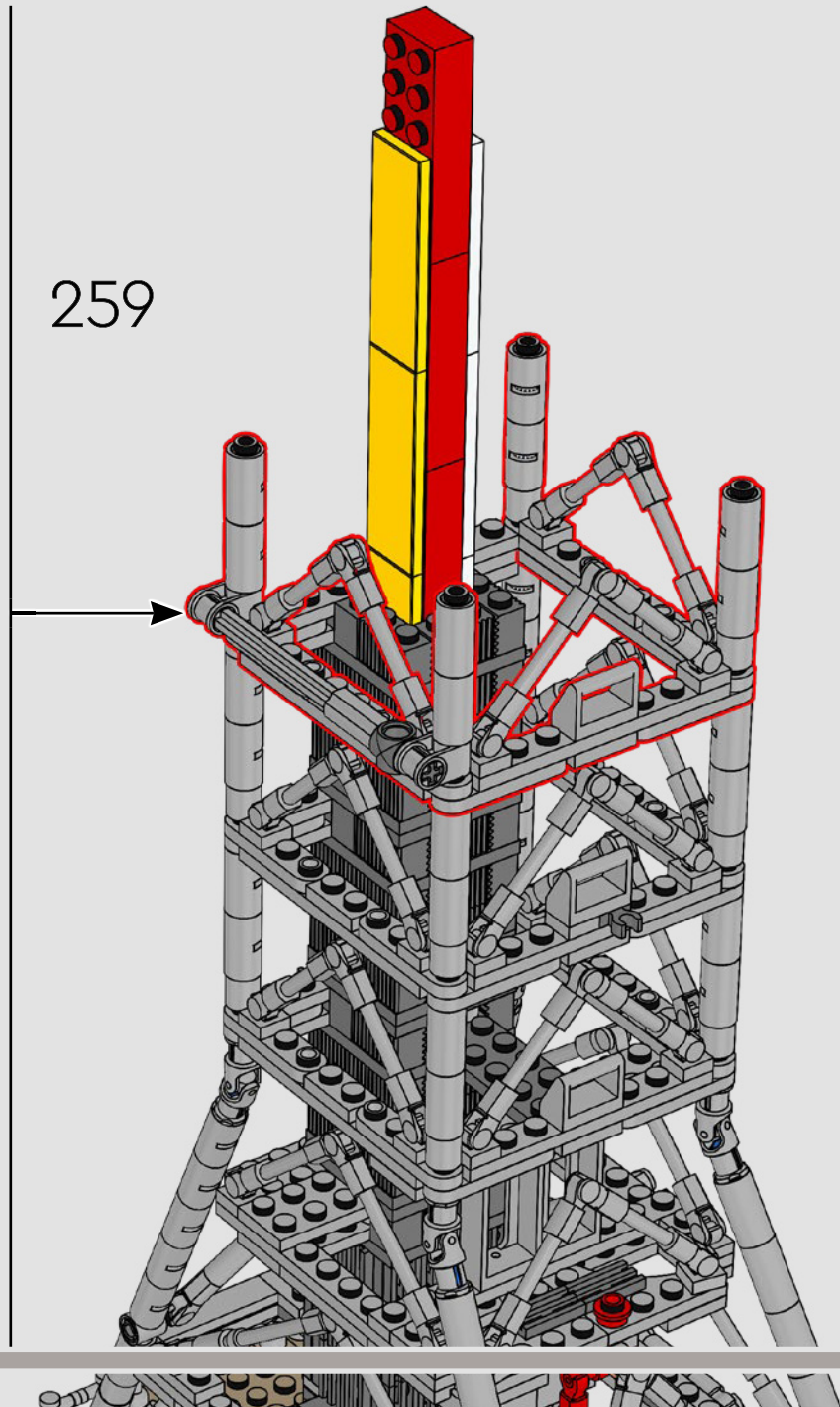

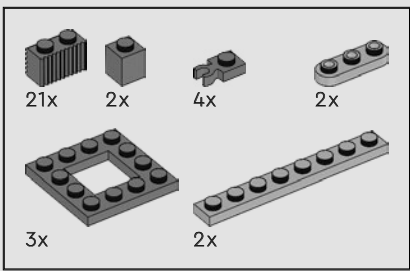

260

1

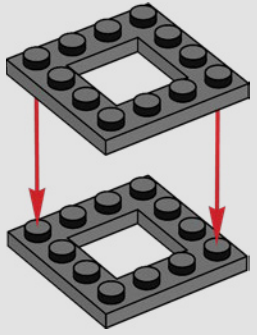

2

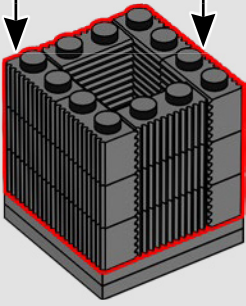

3

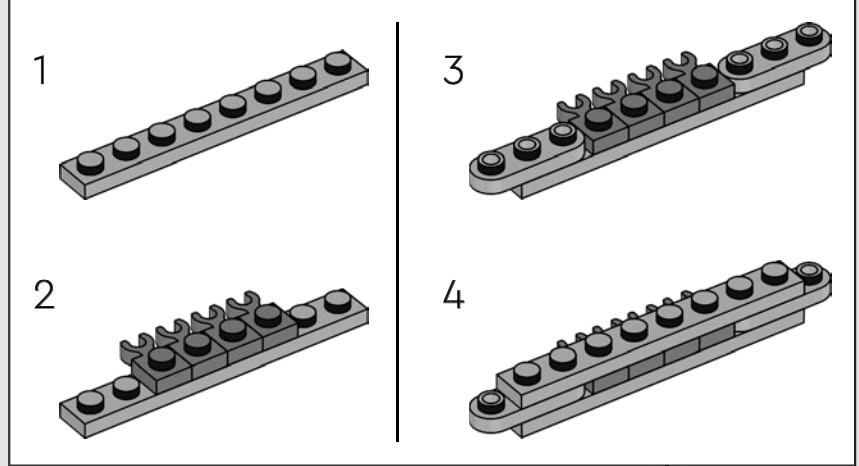
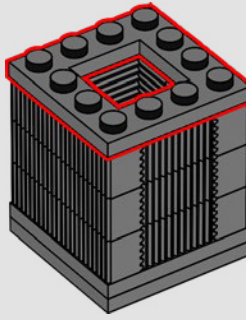

4

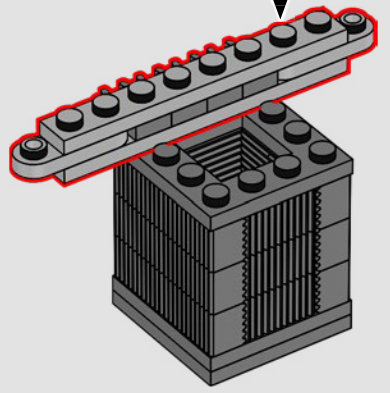

5

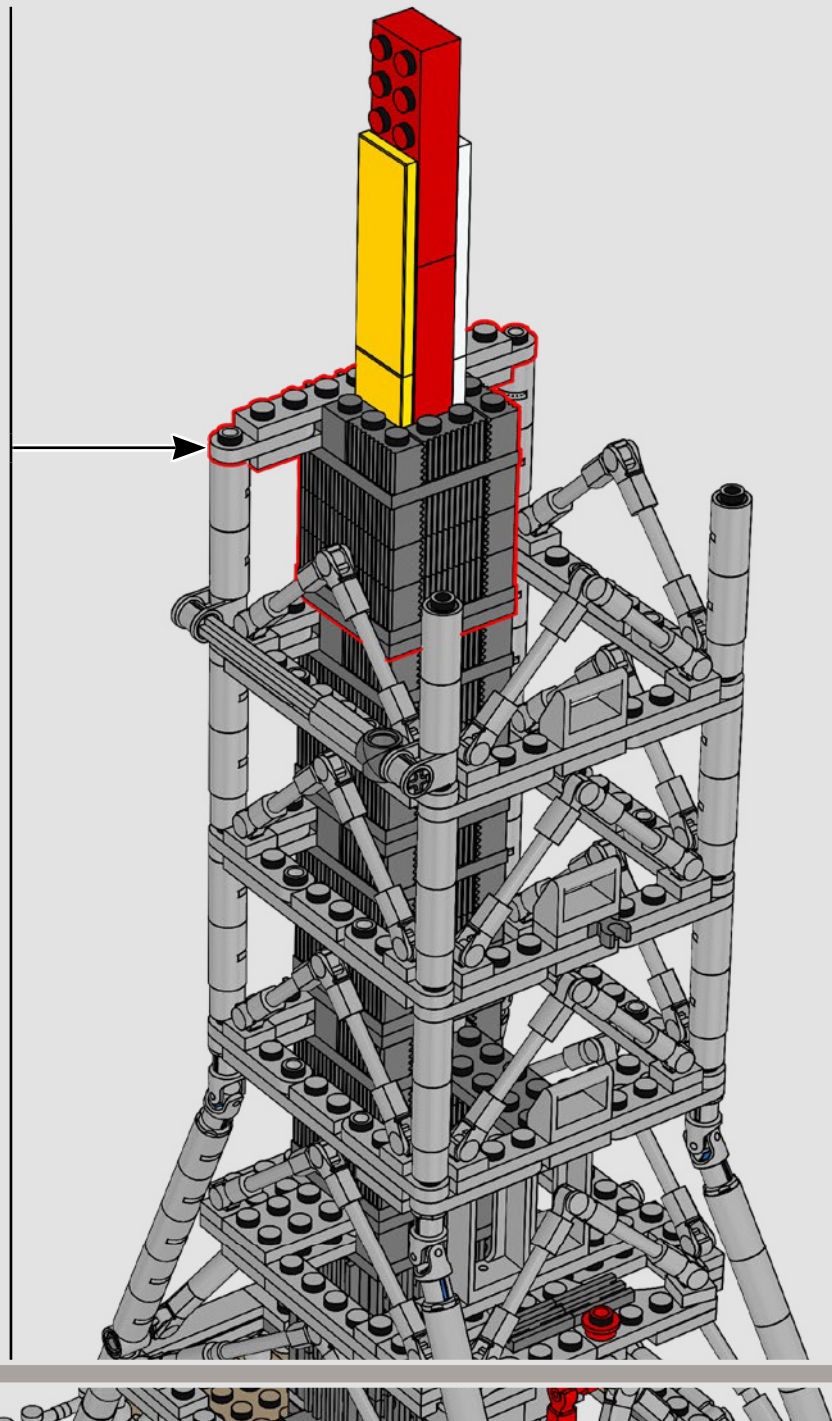
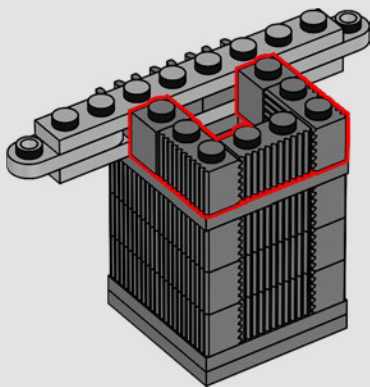

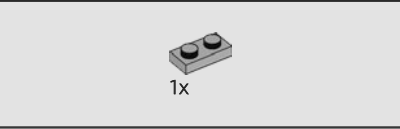
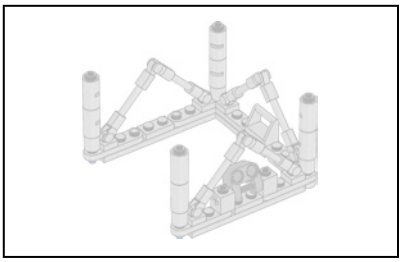

1x

261

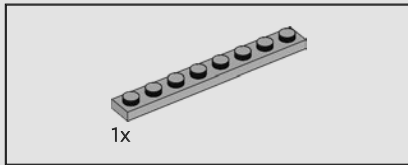
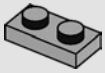

1x

262

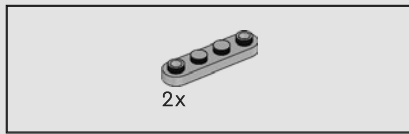
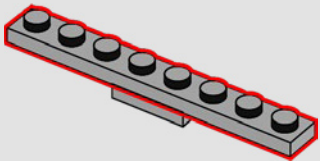

2x

263

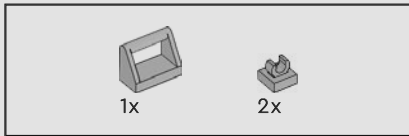
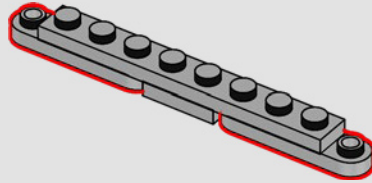

1x

2x

264

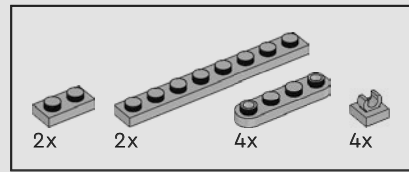
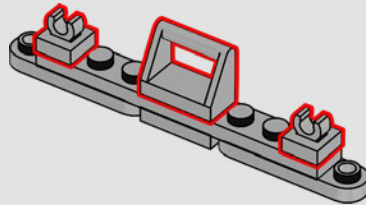

2x

2x

4x

4x

265

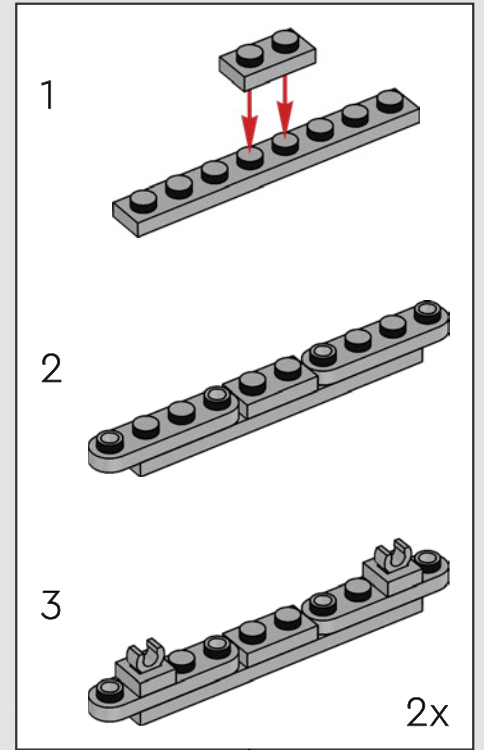

1

2

3

2x

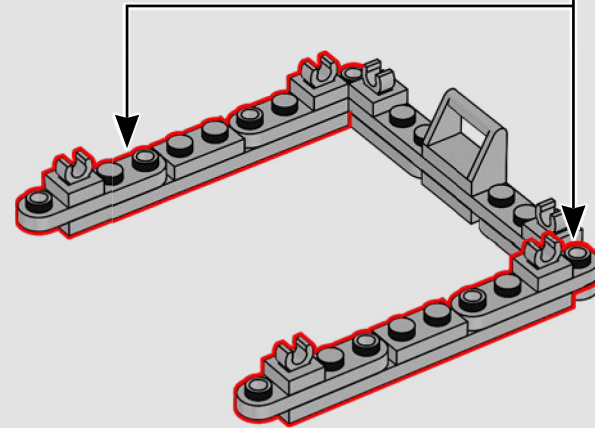

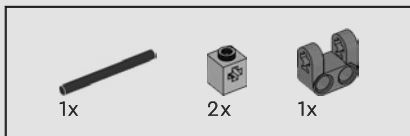

266

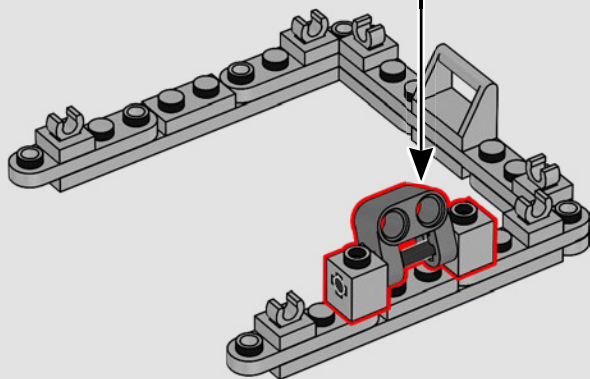
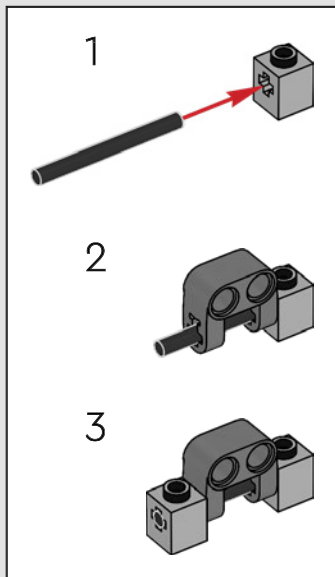

267

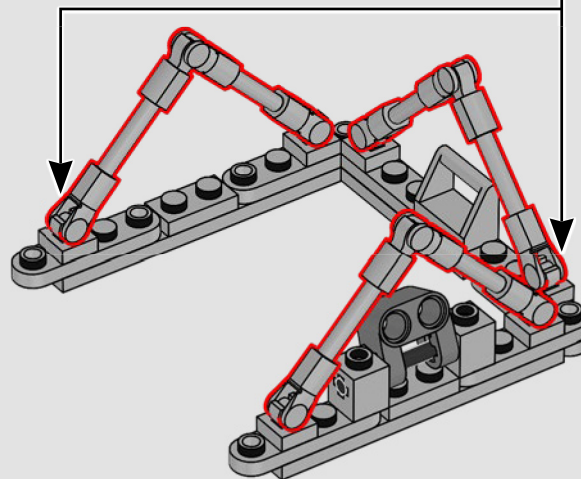
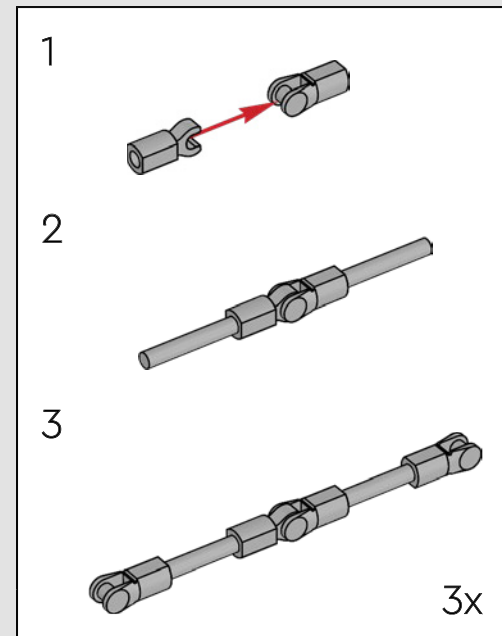

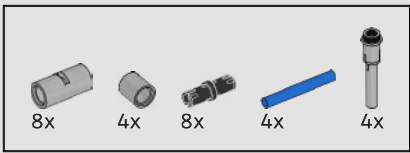

268

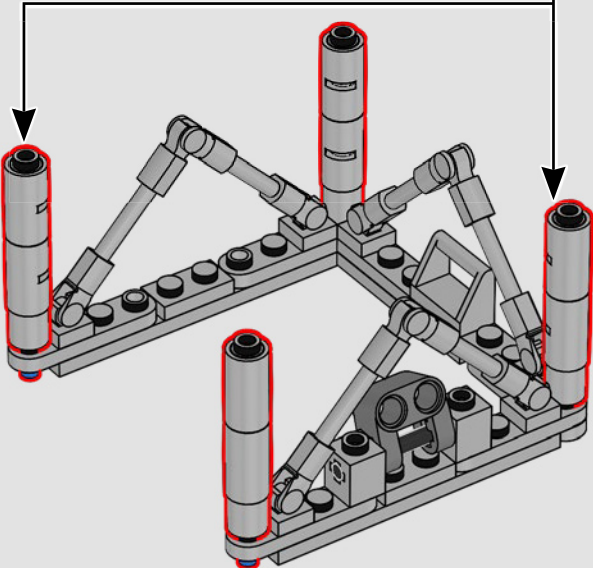
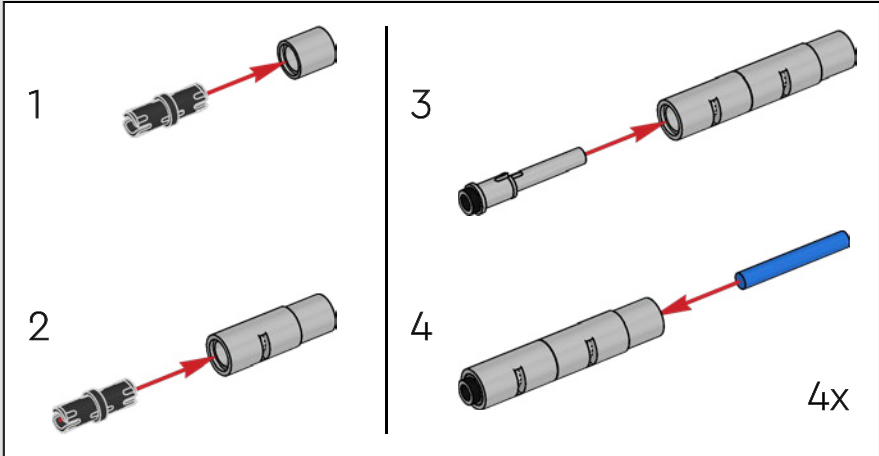

269

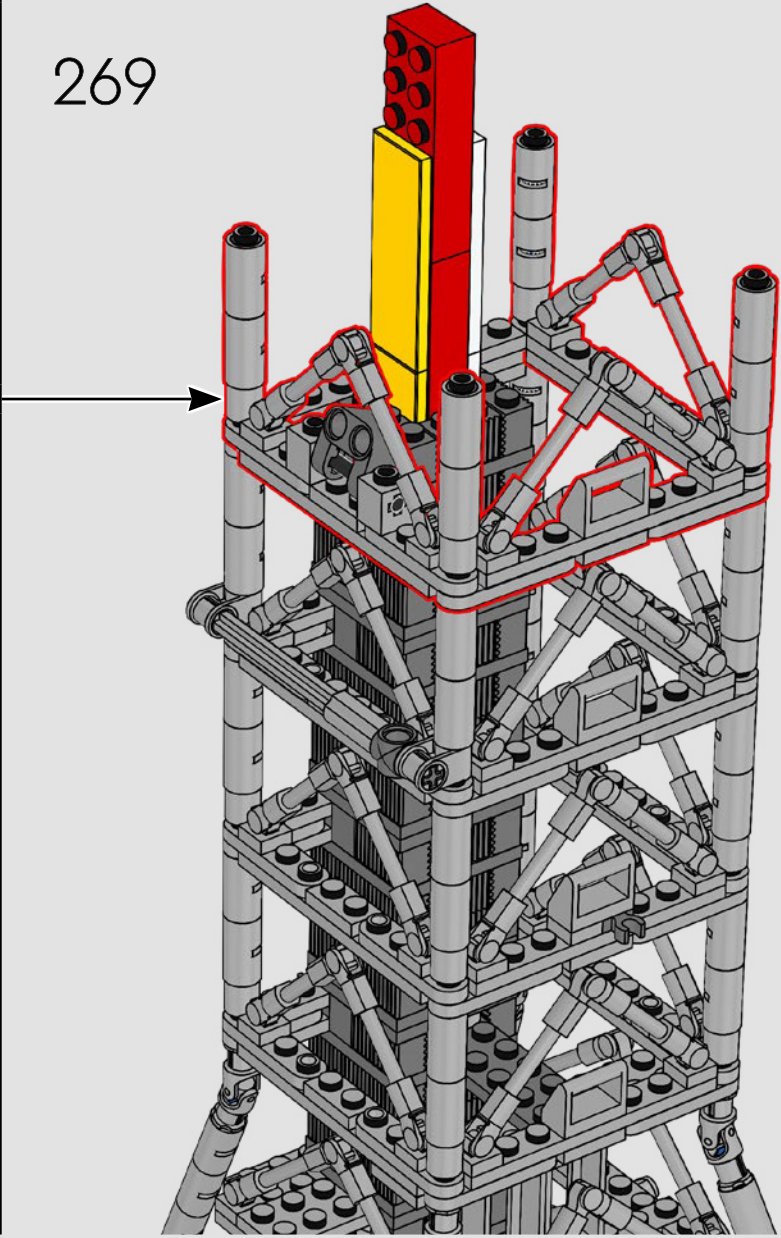

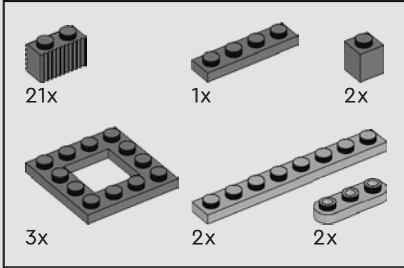
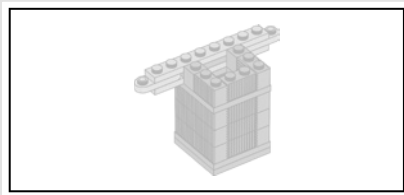

270

1

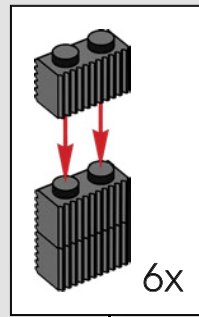
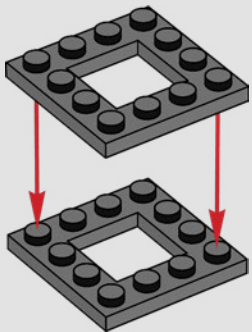

2

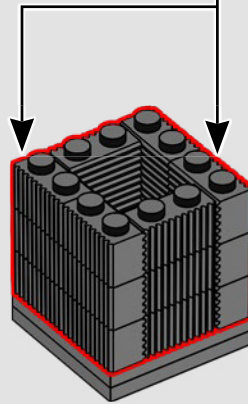

3

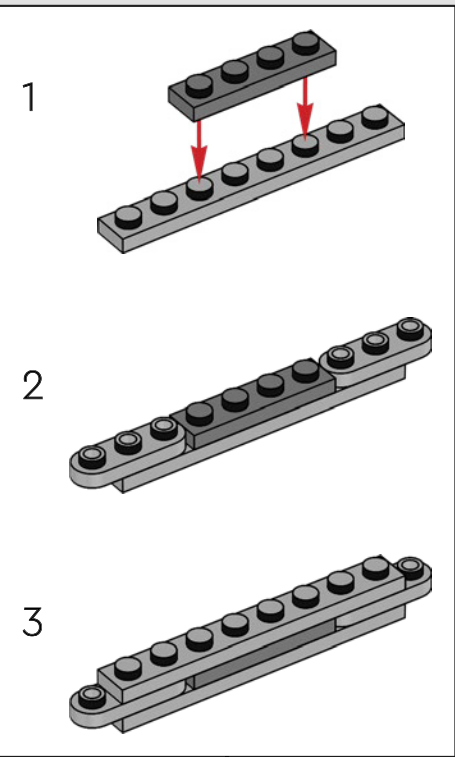
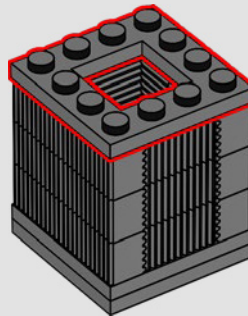

2

3

4

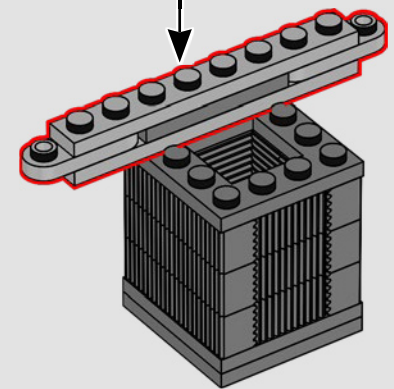

5

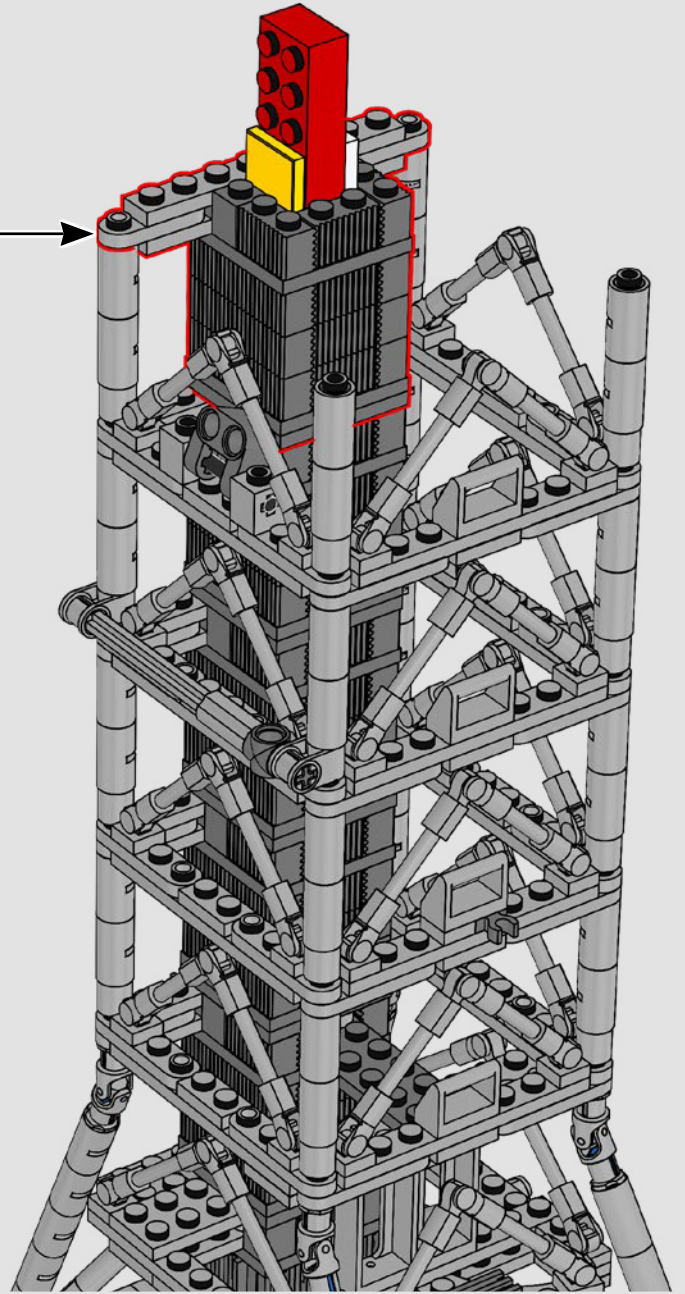
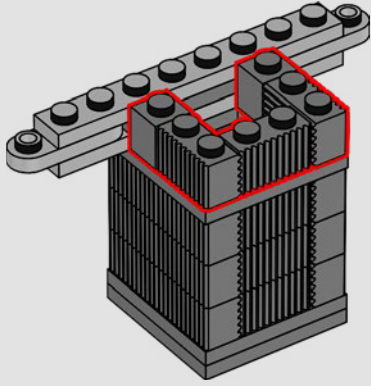

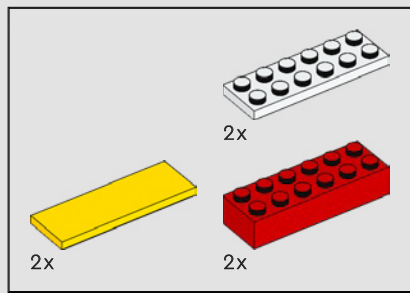

271

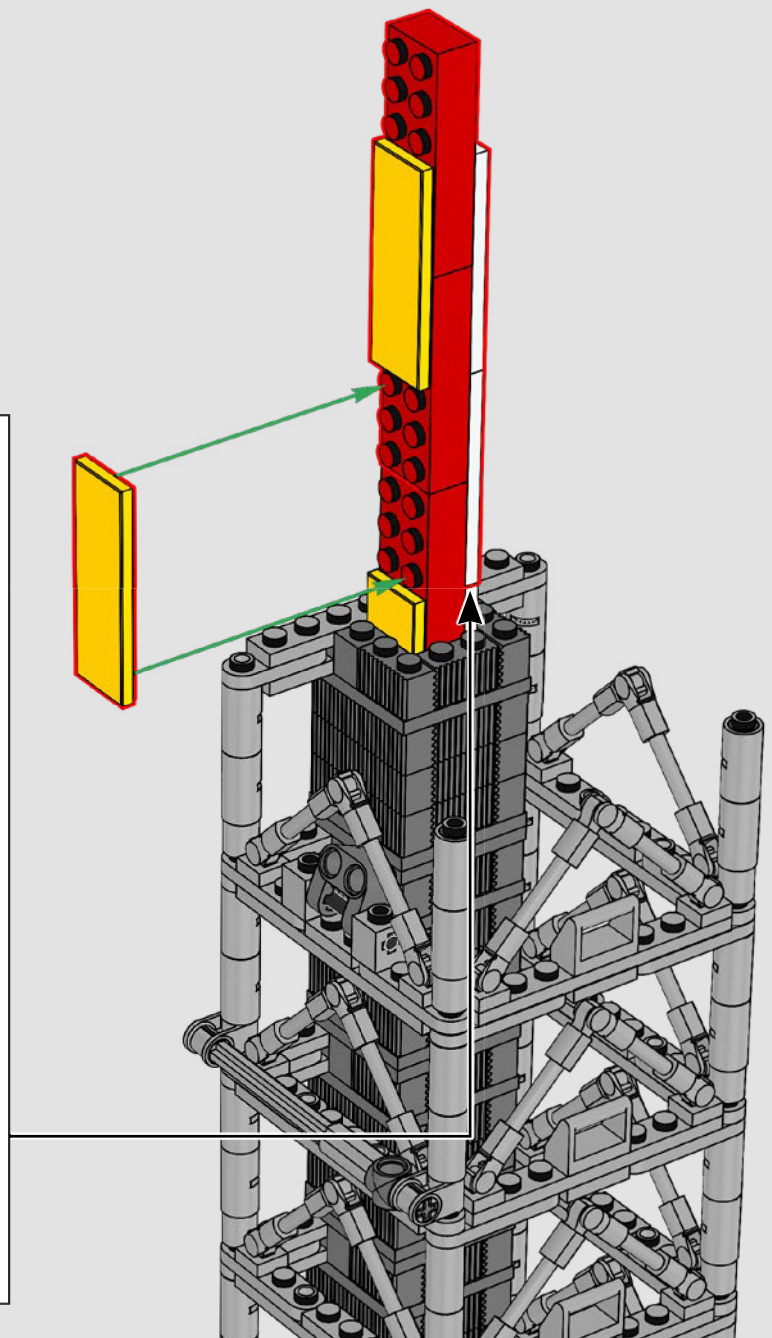
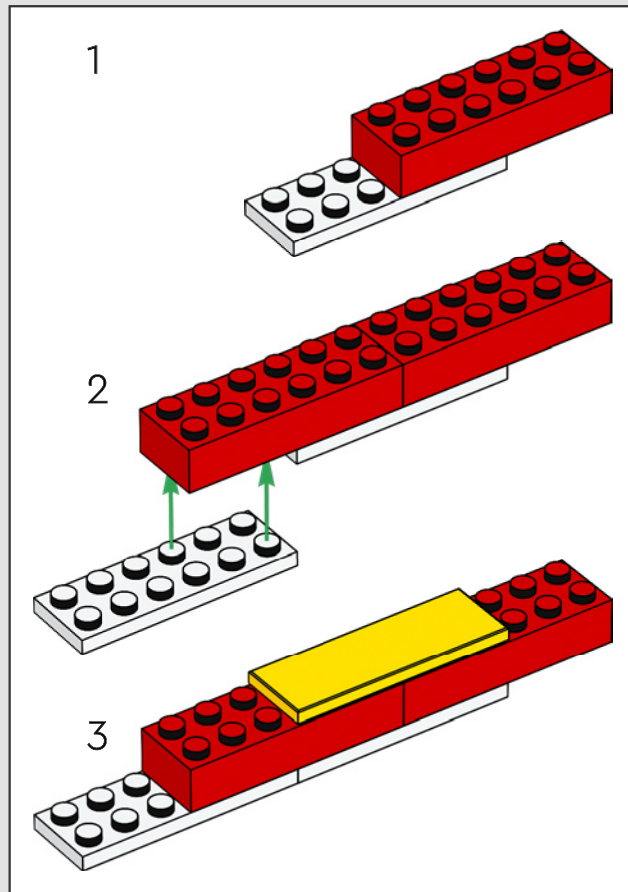

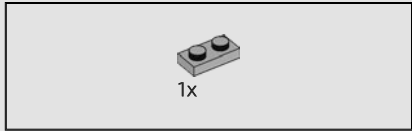
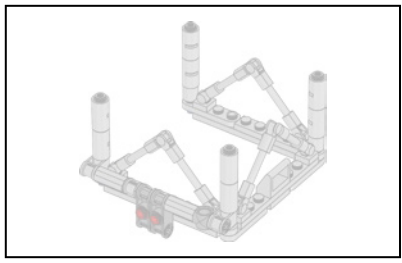

272

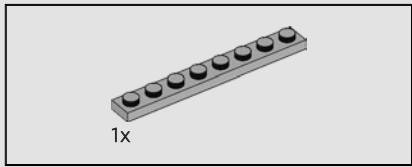
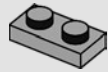

273

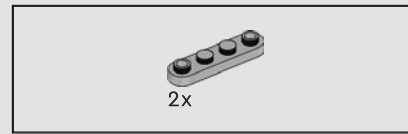
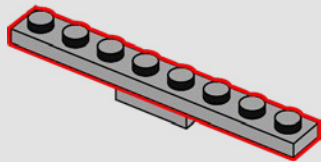

274

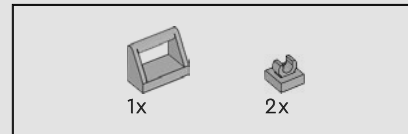
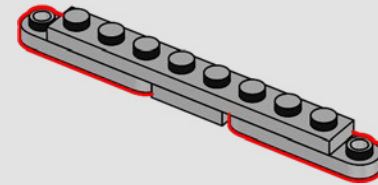

275

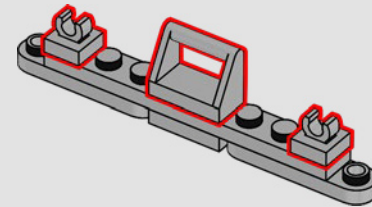

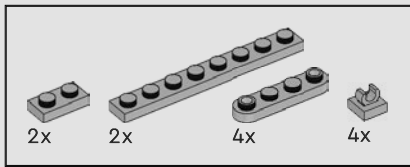

276

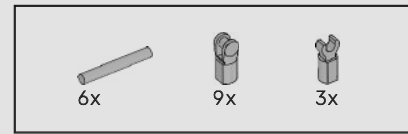
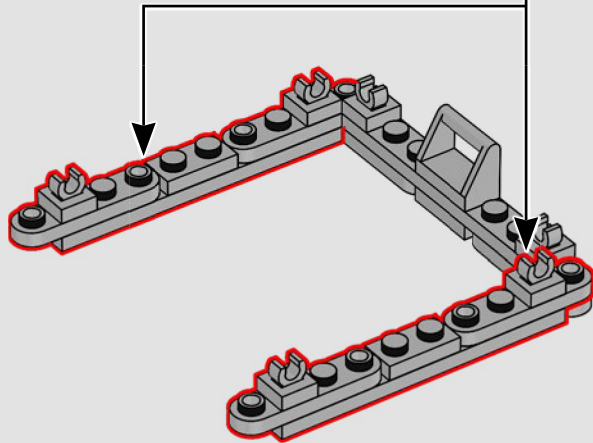
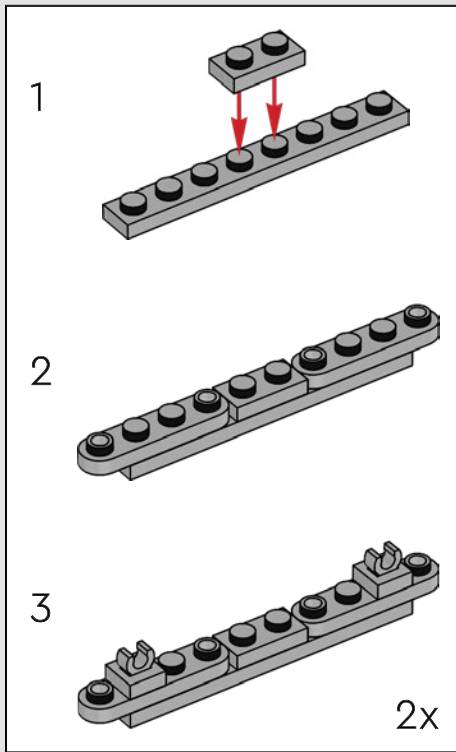

277

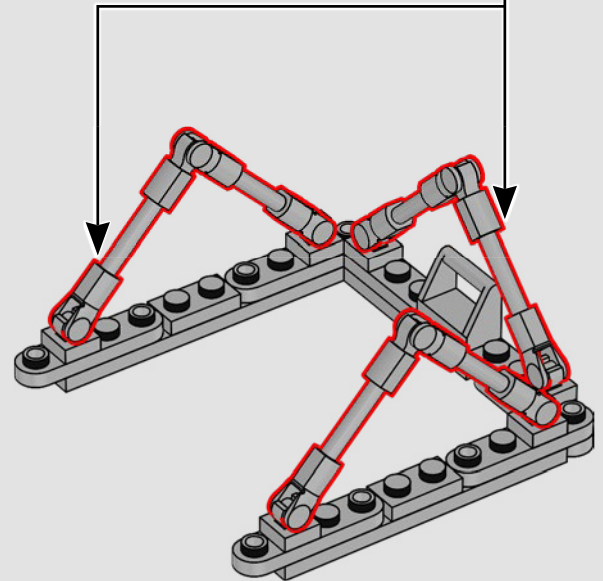
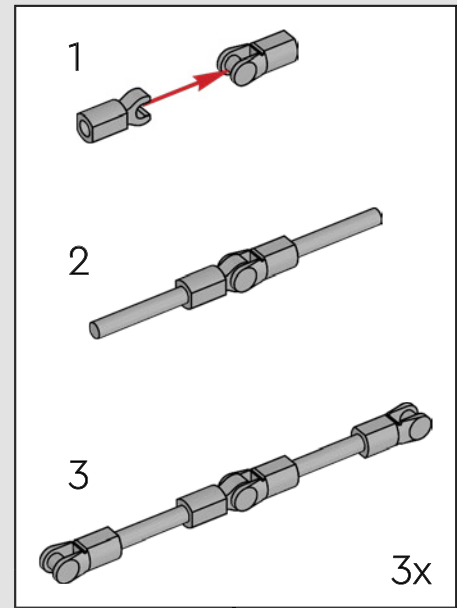

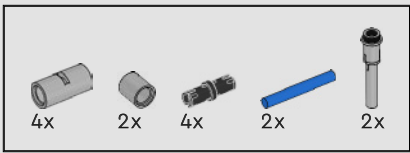

278

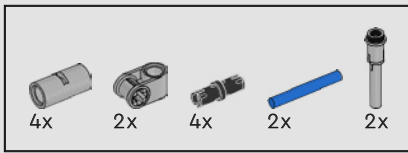
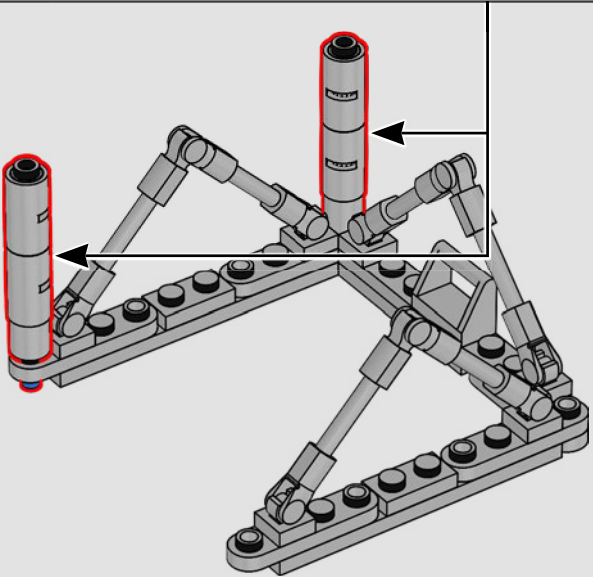
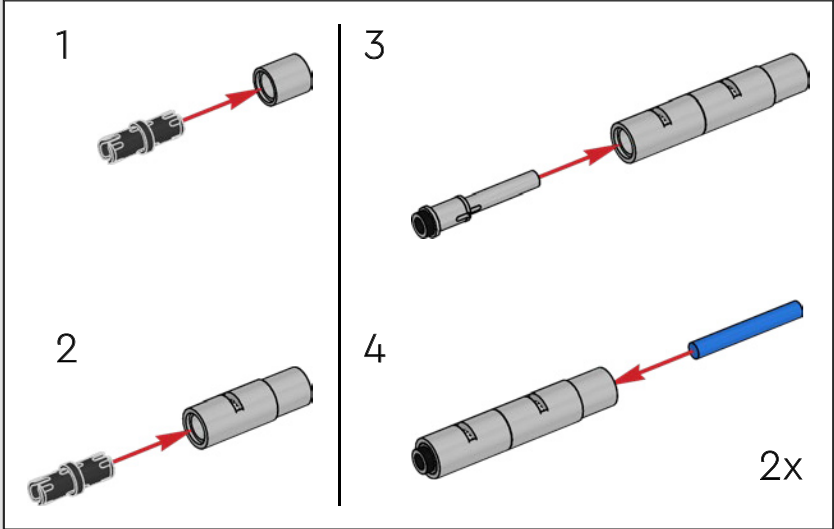

279

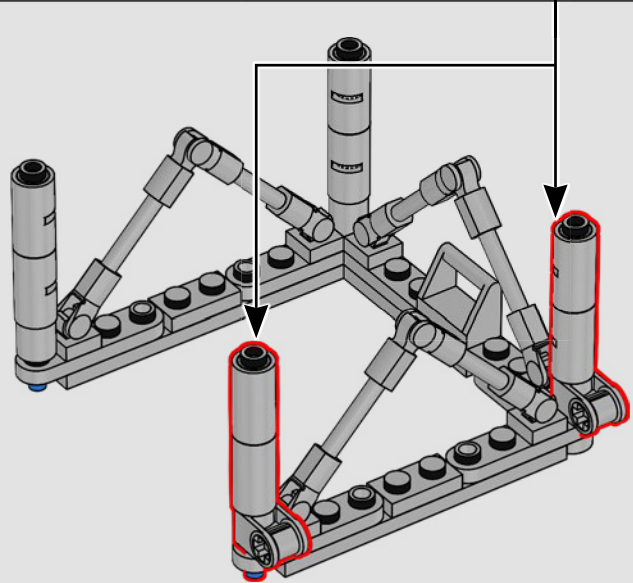
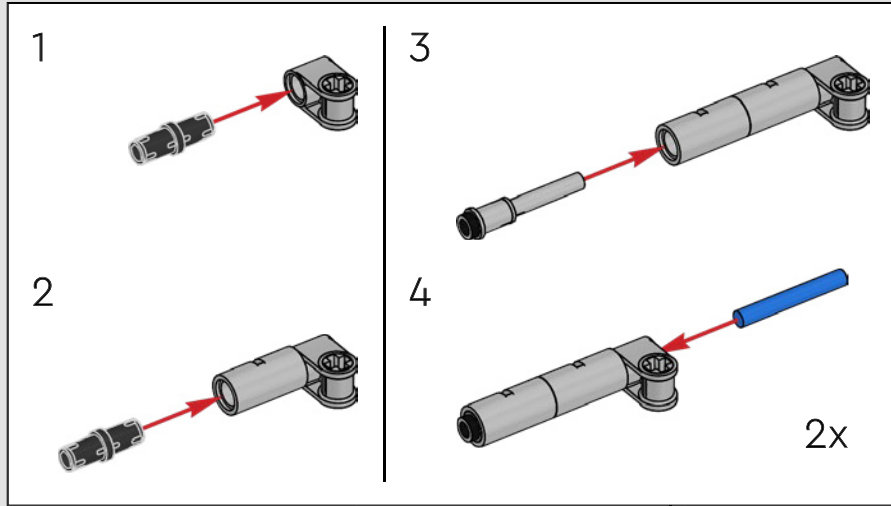

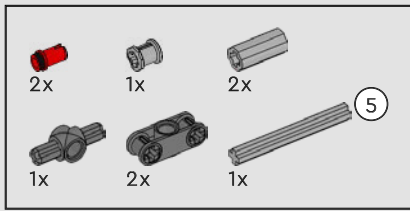

280

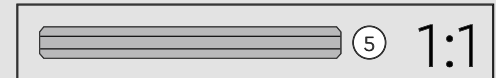
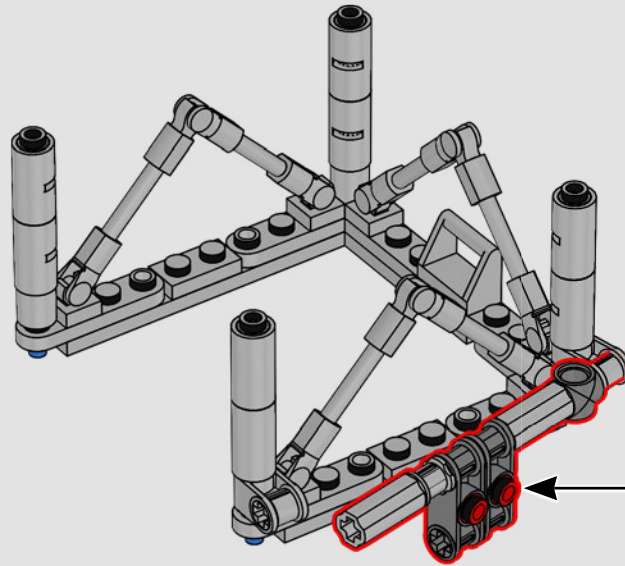
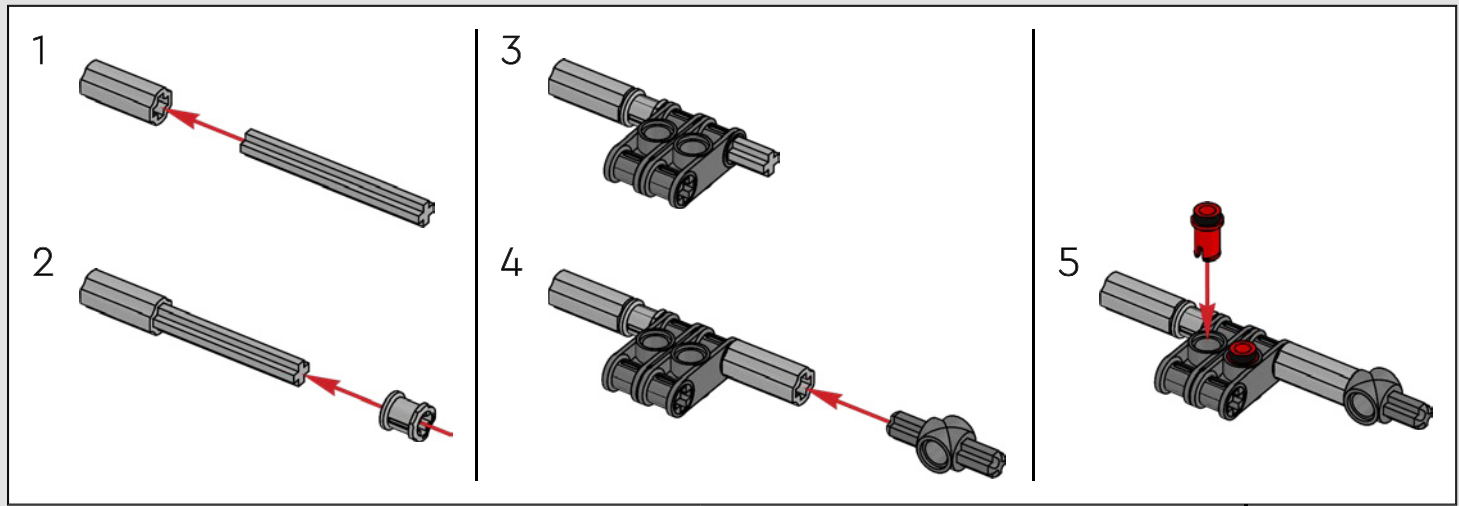



1x

281

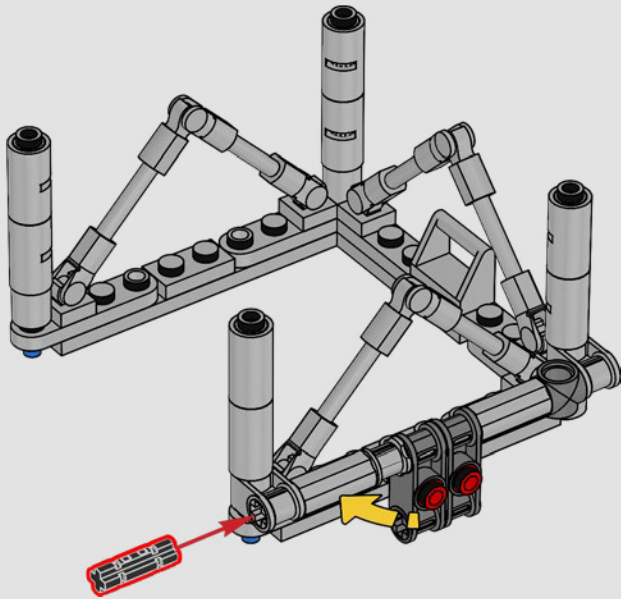

282

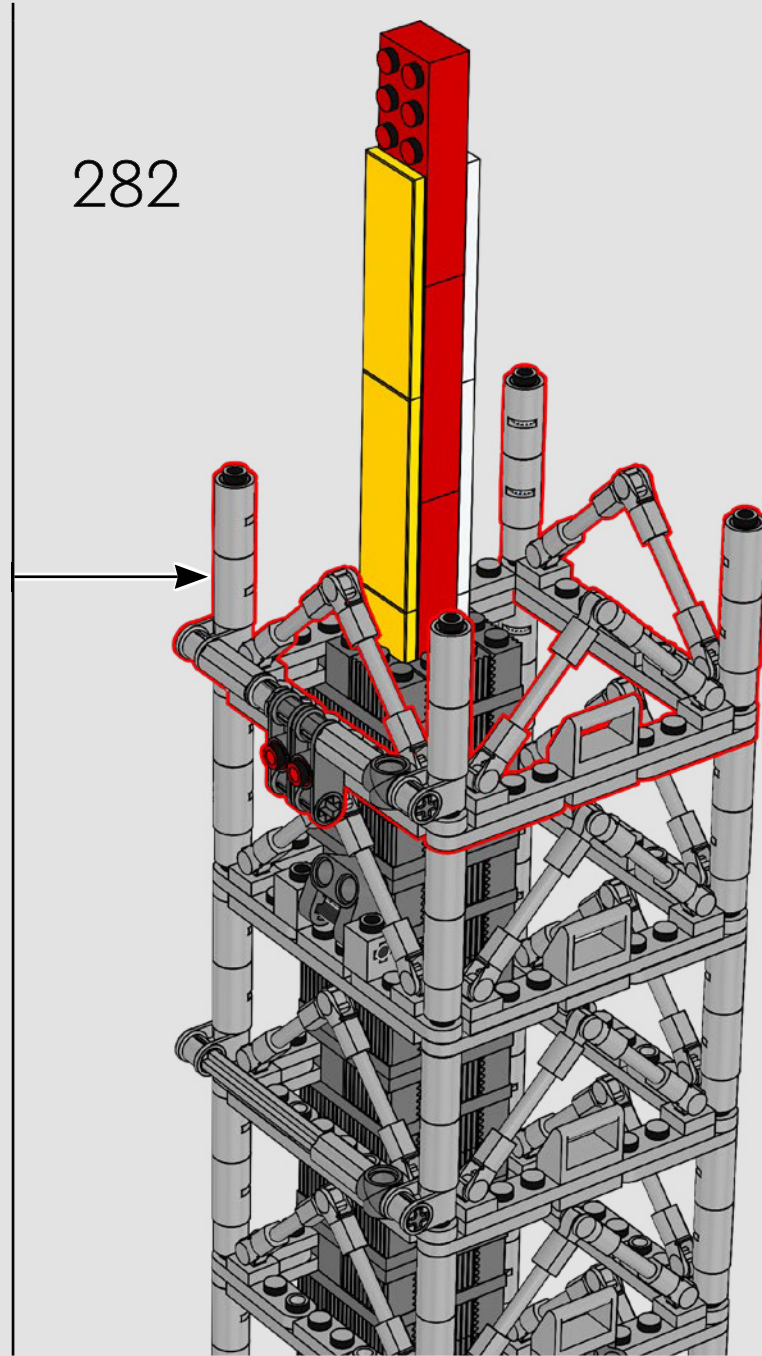

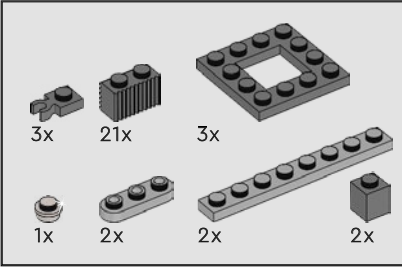
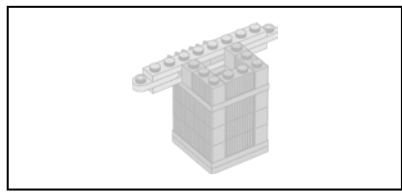

283

1

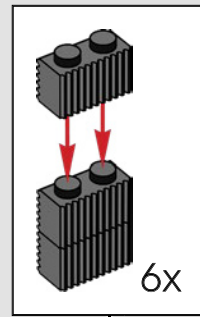
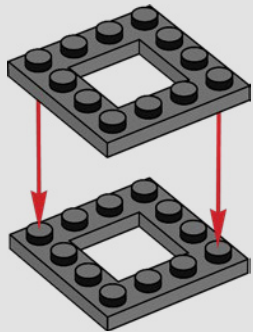

2

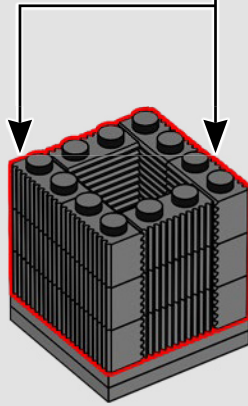

3

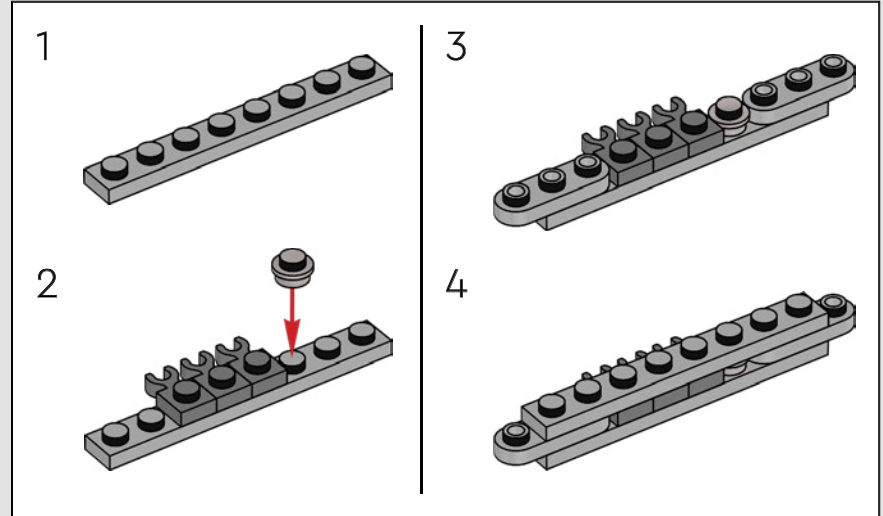
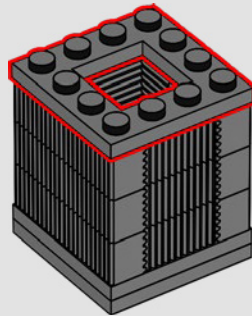

4

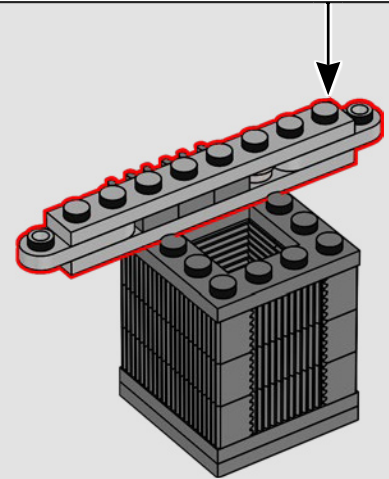

5

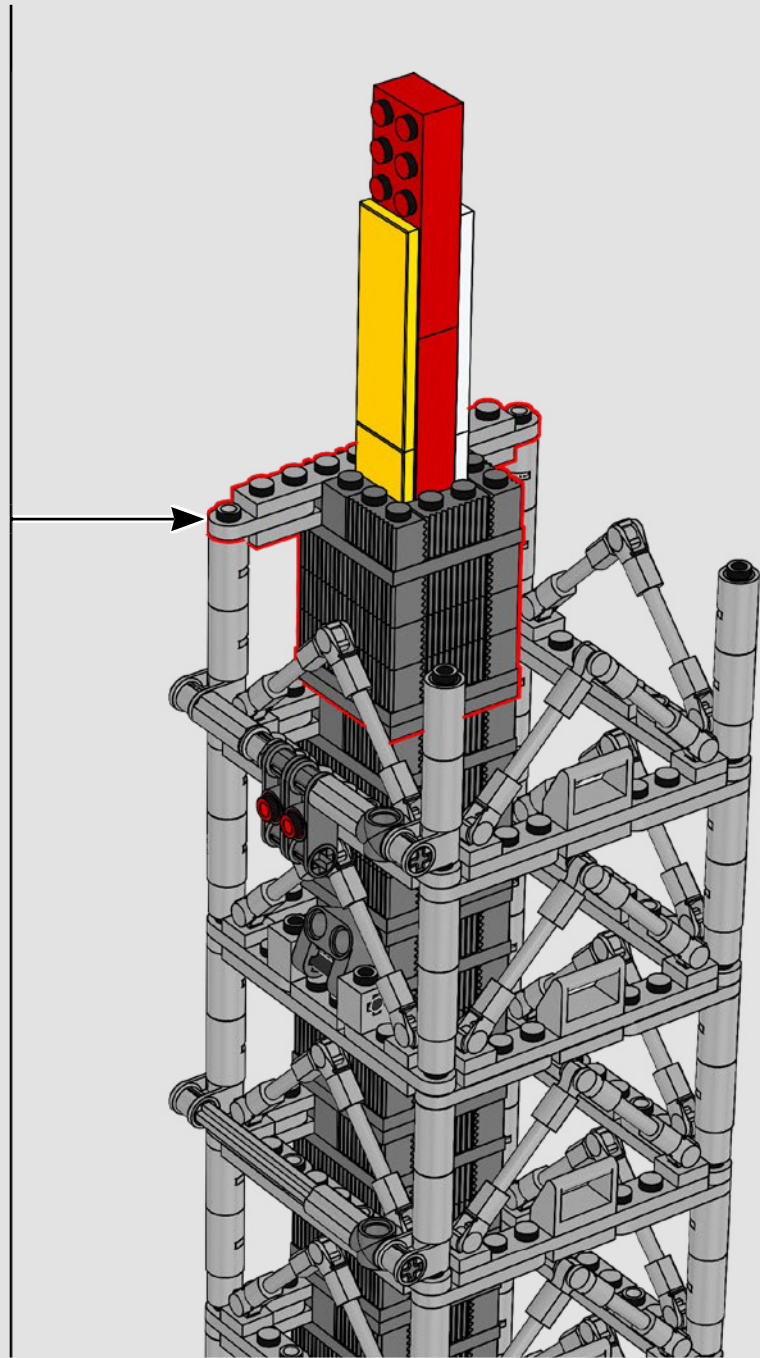
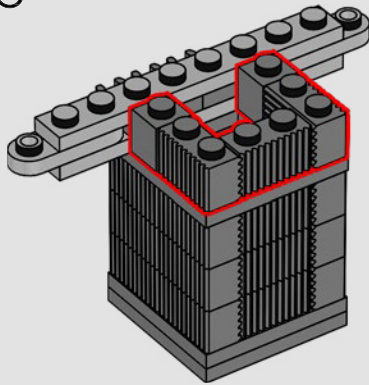

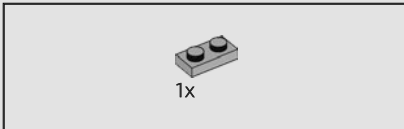
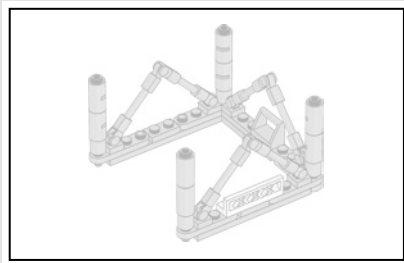

1x

284

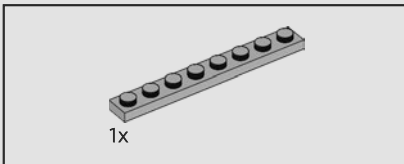

1x

285

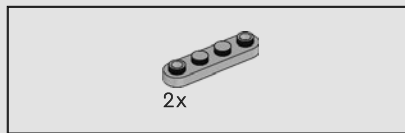
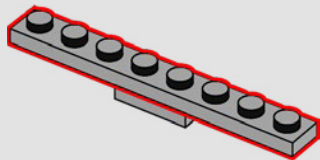

2x

286

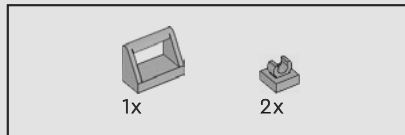
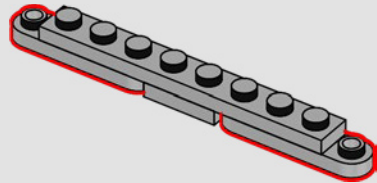

1x

2x

287

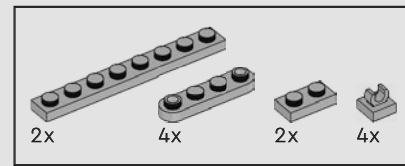
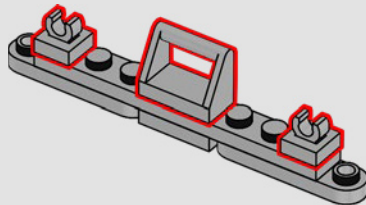

2x

4x

2x

4x

288

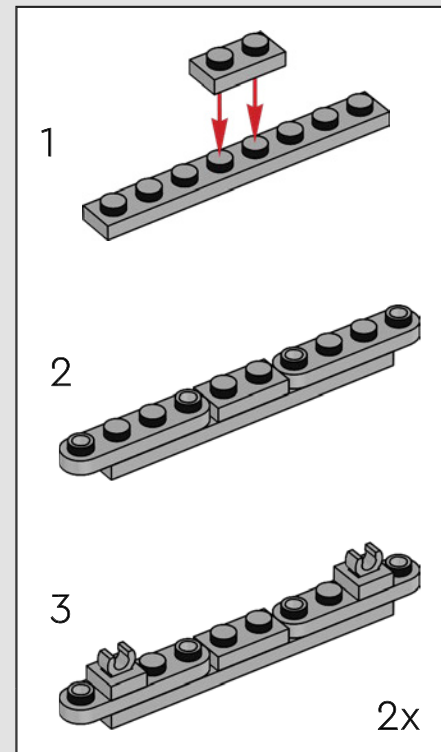

1

2

3

2x

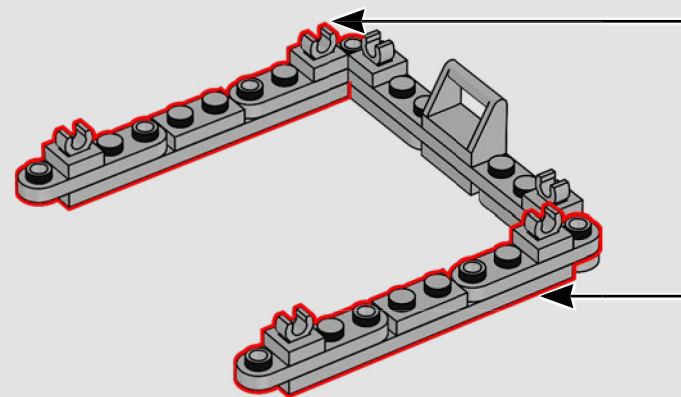

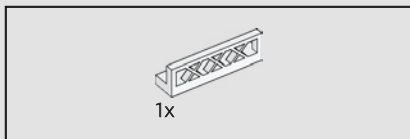

289

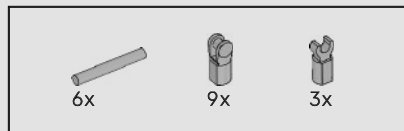
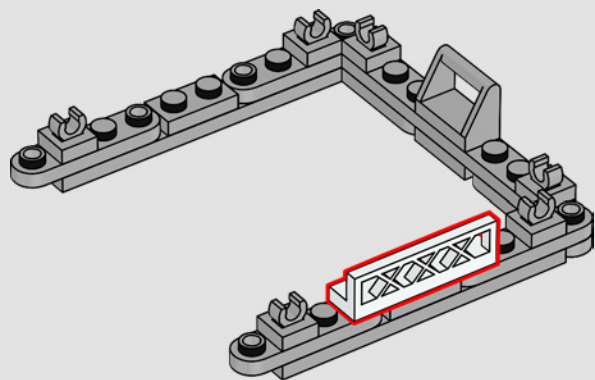

290

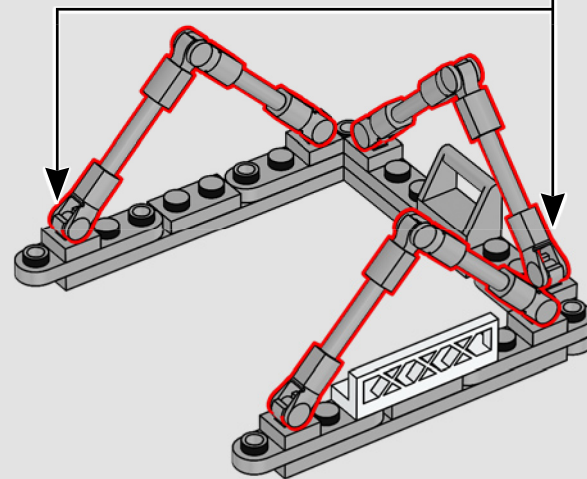
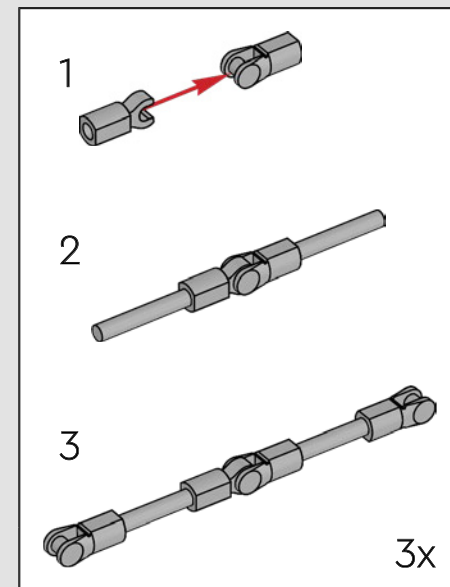

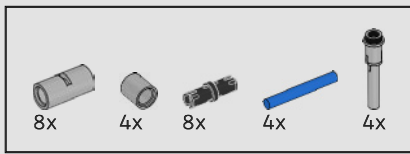

291

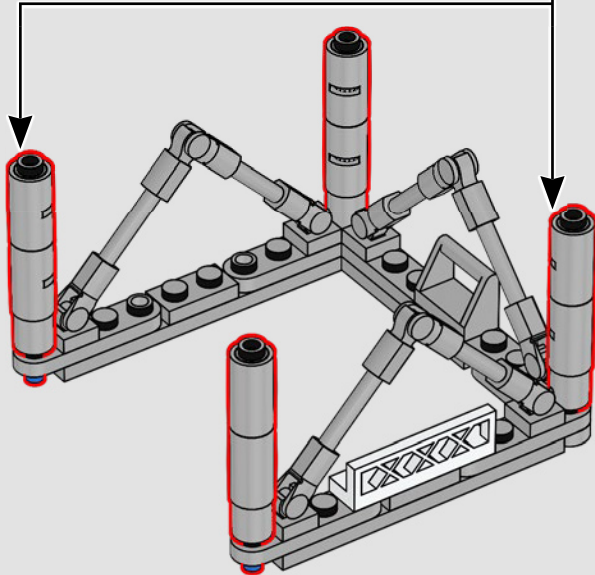
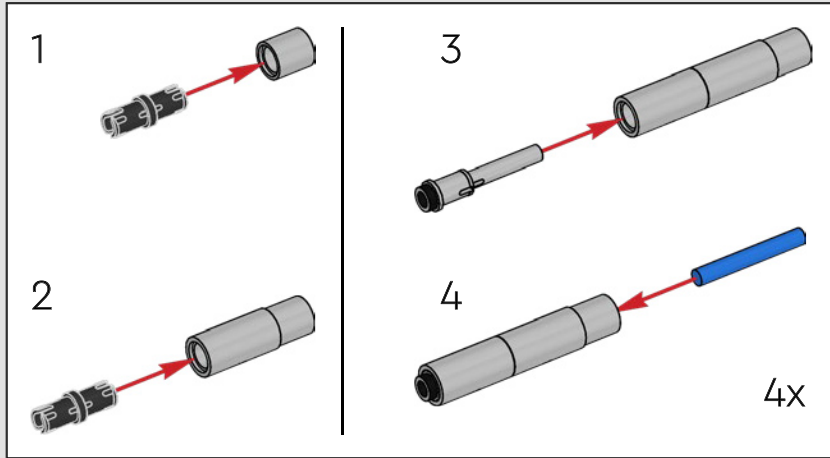

292

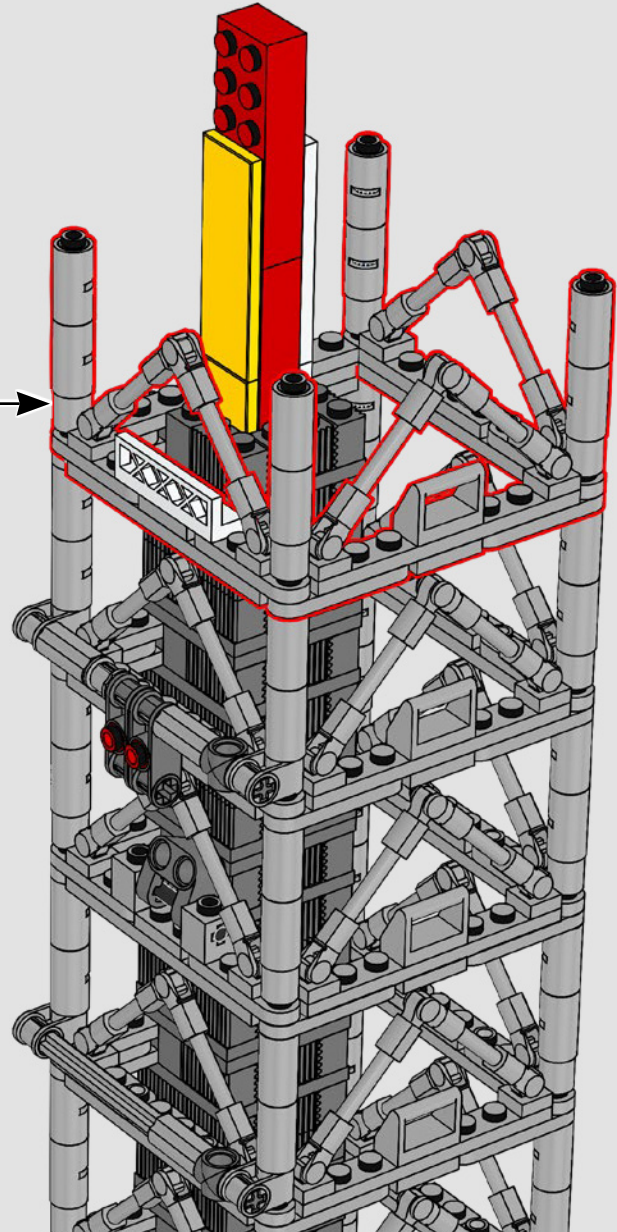

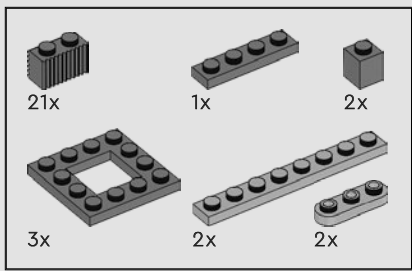

293

1

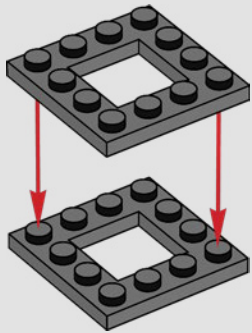

2

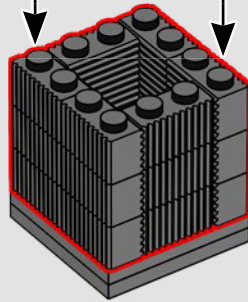

3

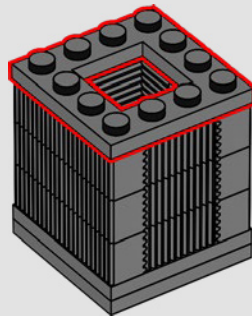

4

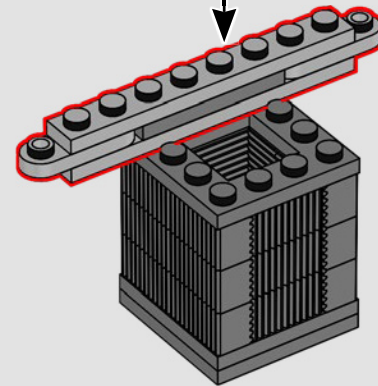

1

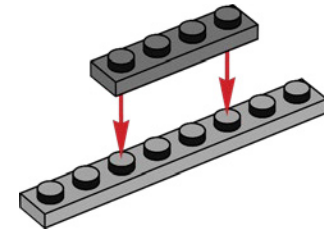

2

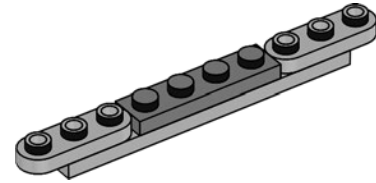

3

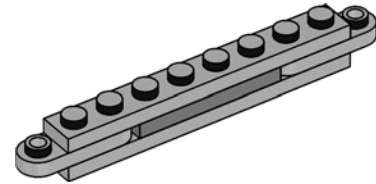

5

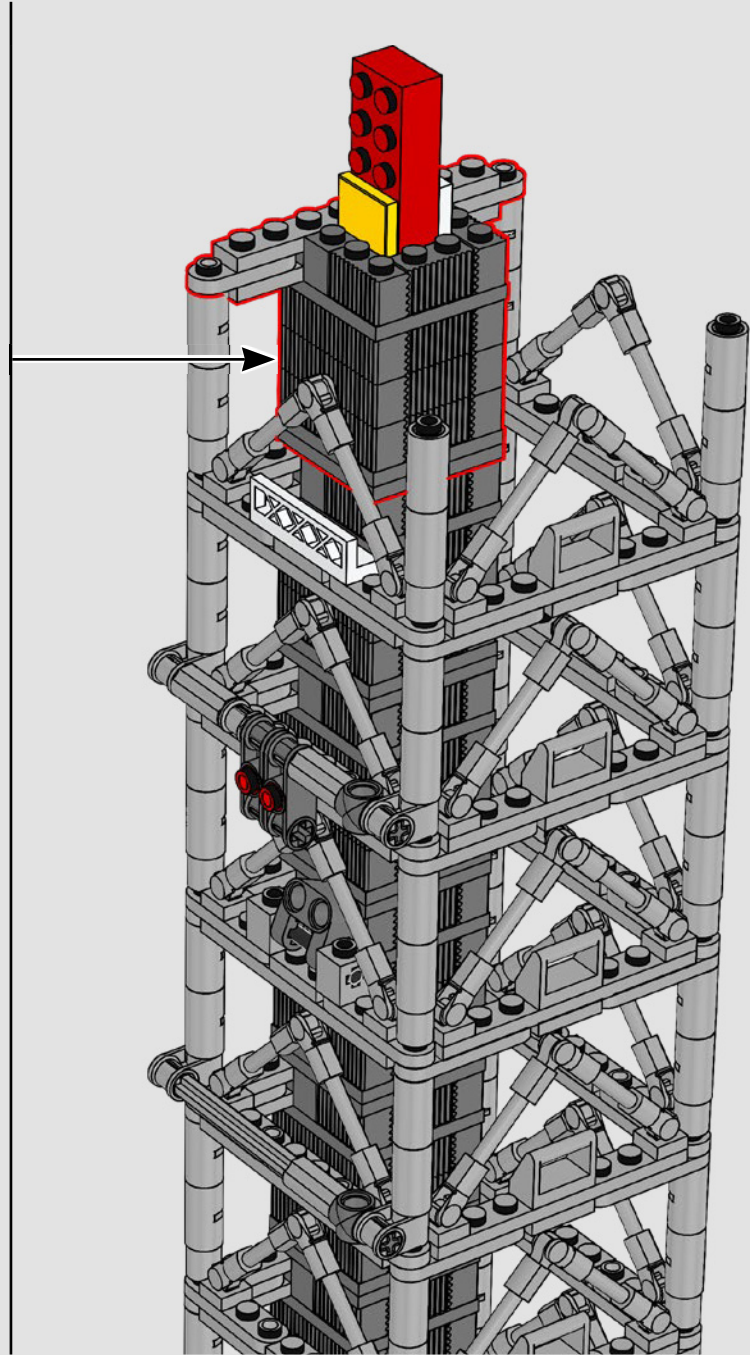
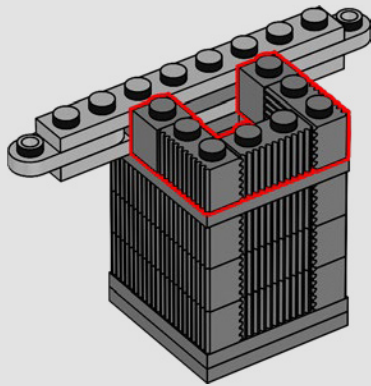

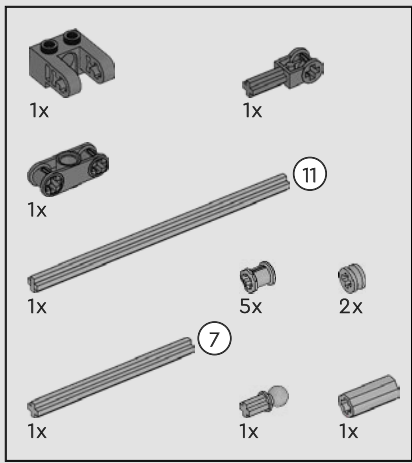

294

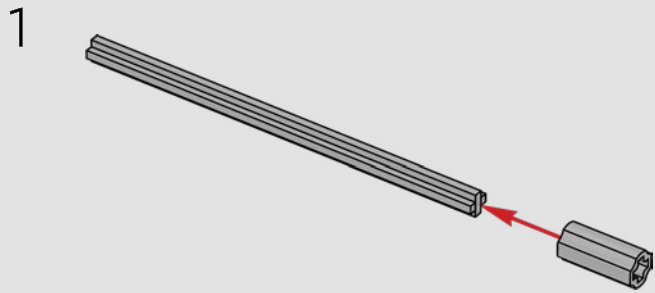

2

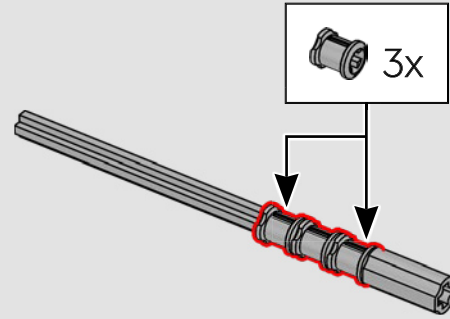

3

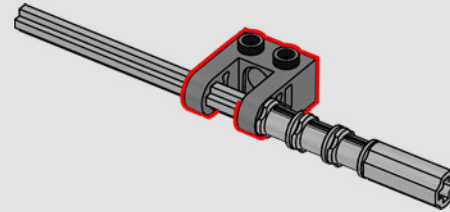

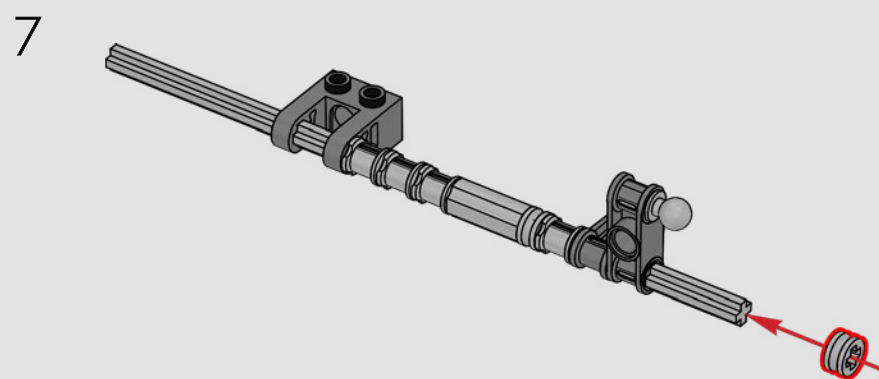
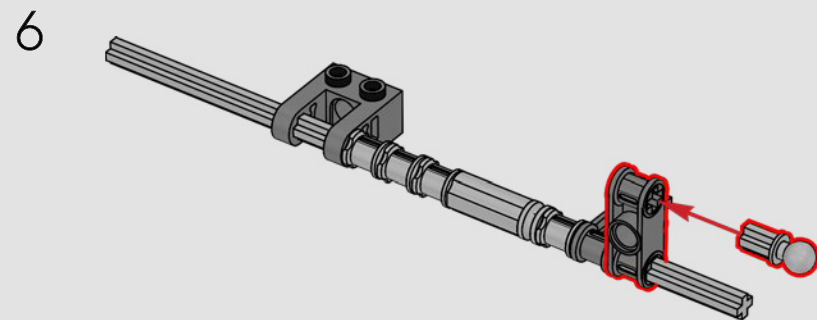
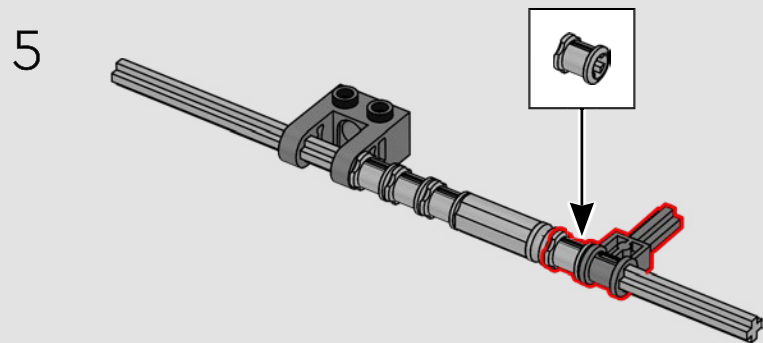
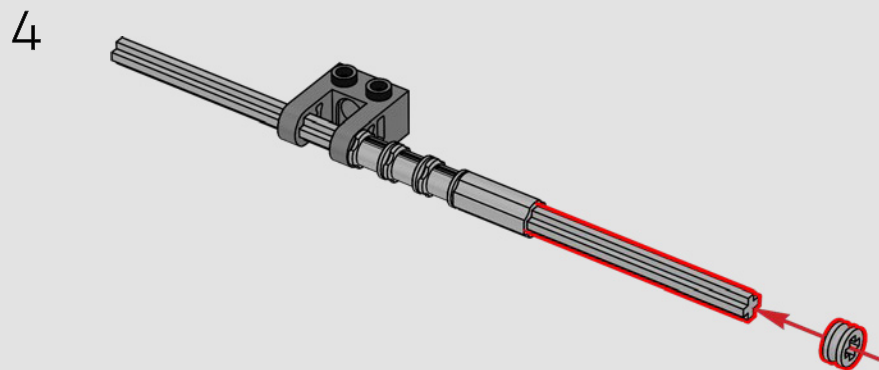

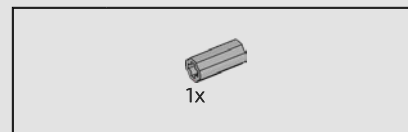
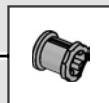
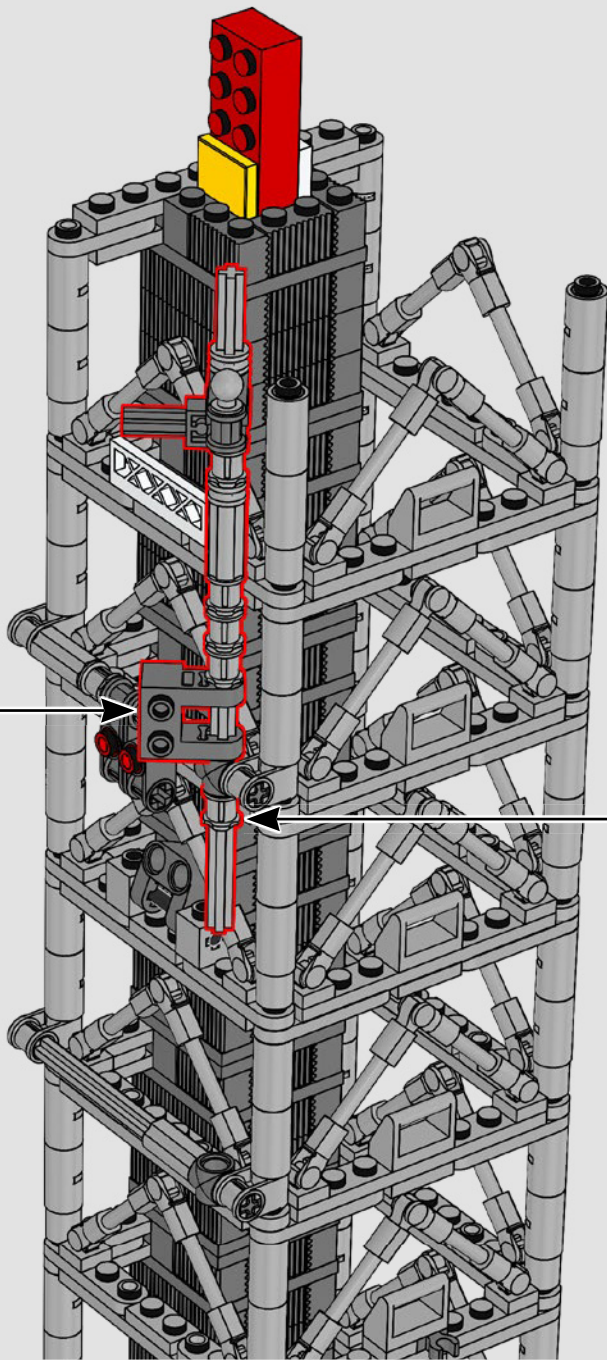

295

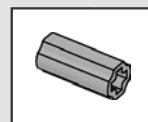
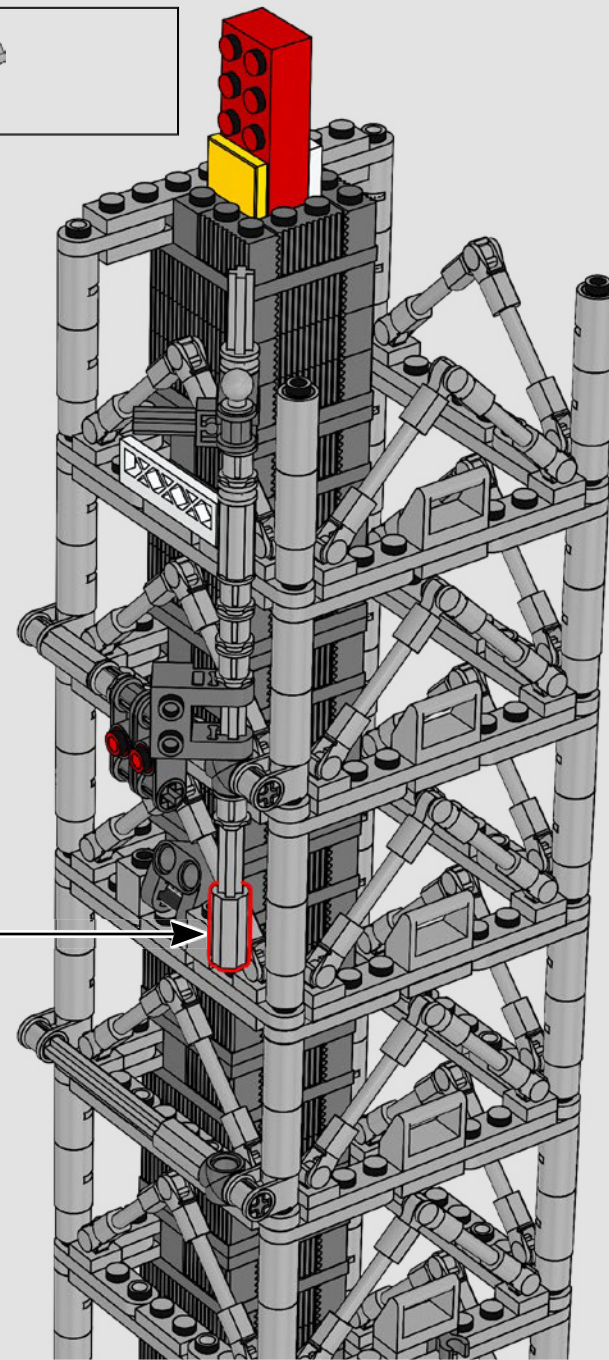

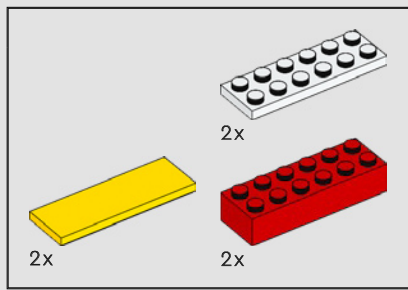

296

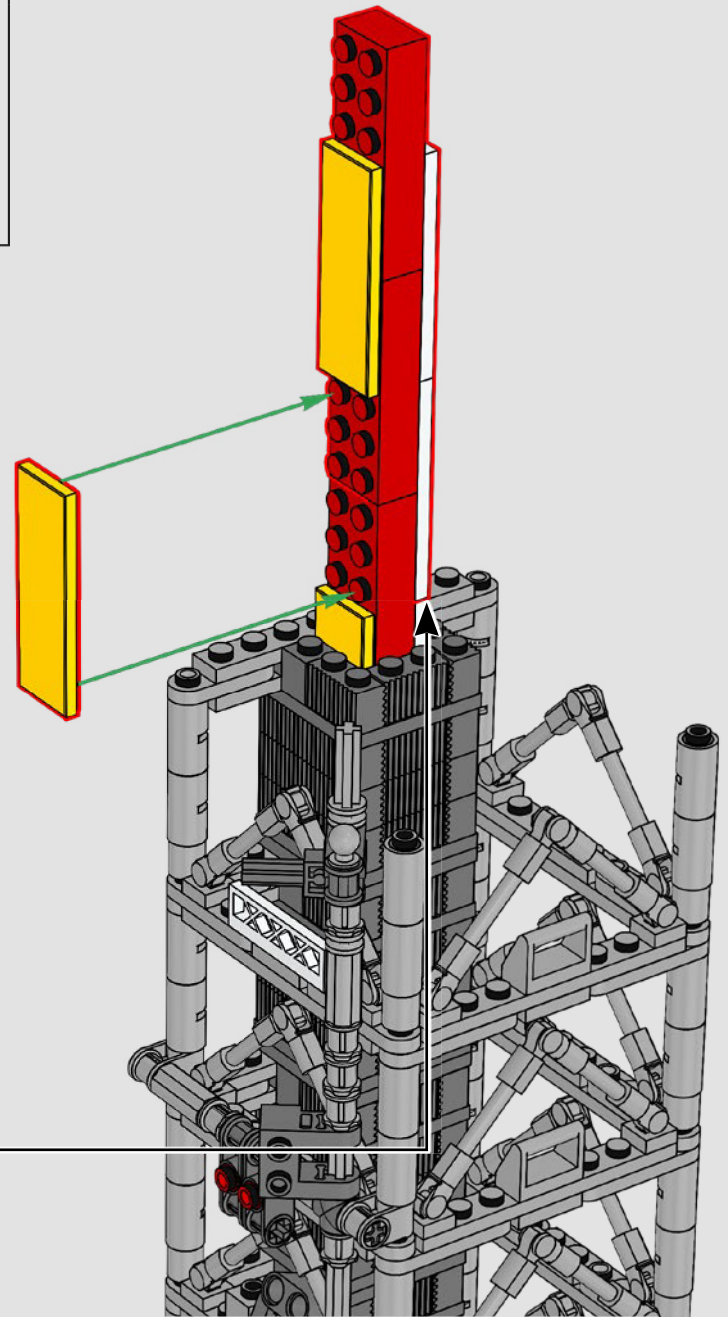
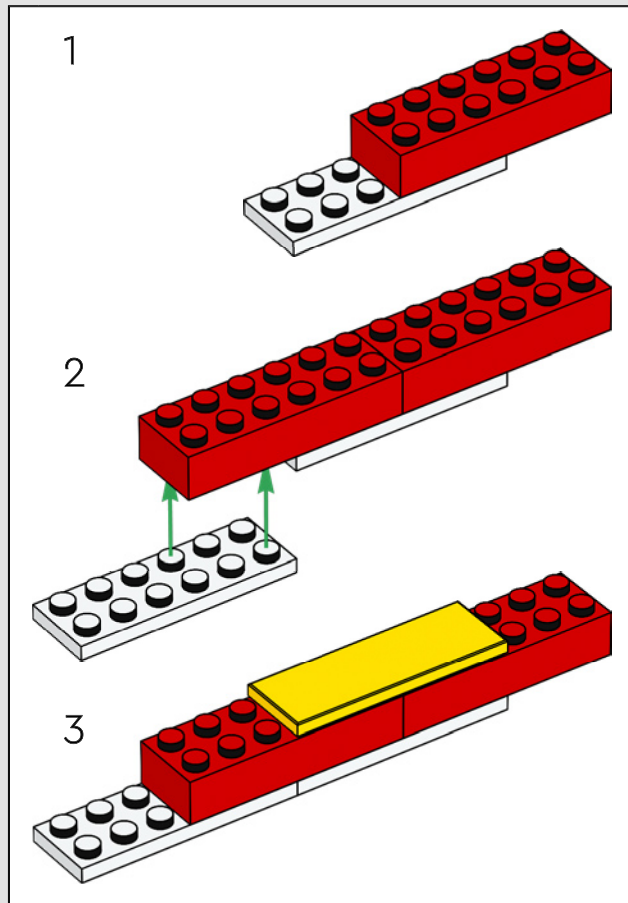

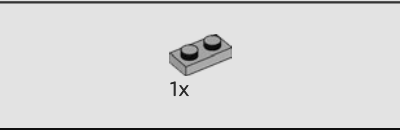
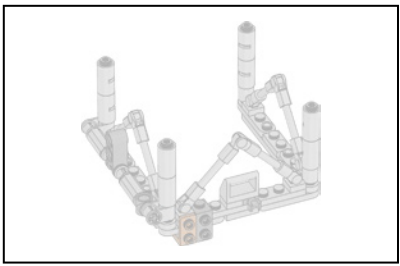

297

1x

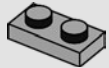

298

1x

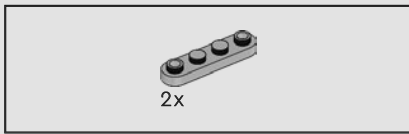
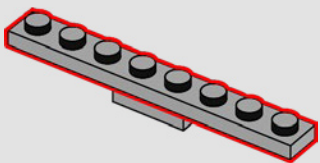

2x

299

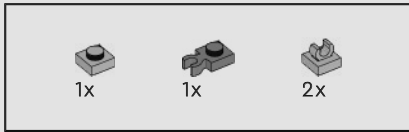
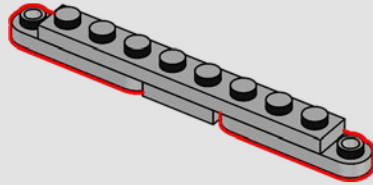

300

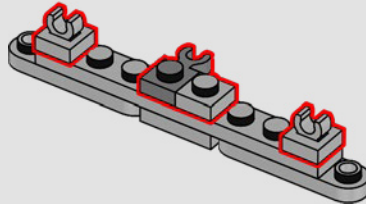

1x

301

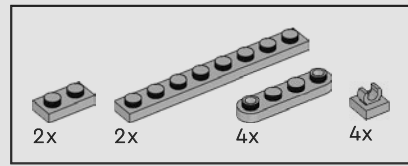
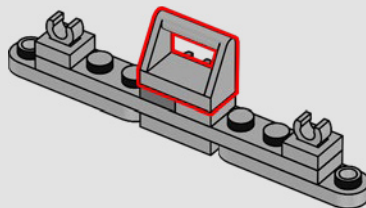

302

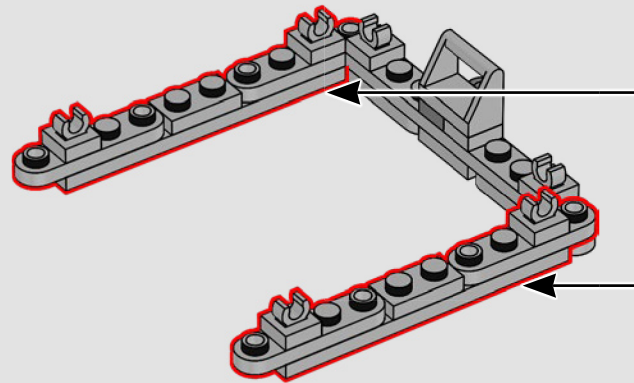
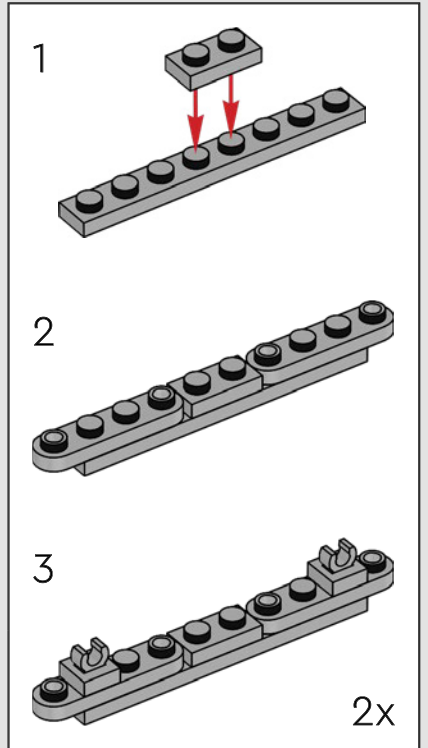

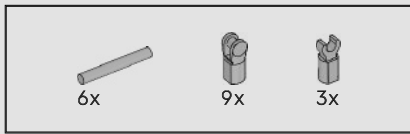

303

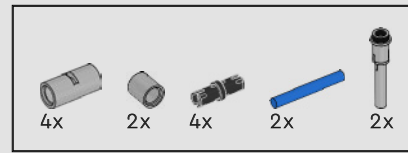
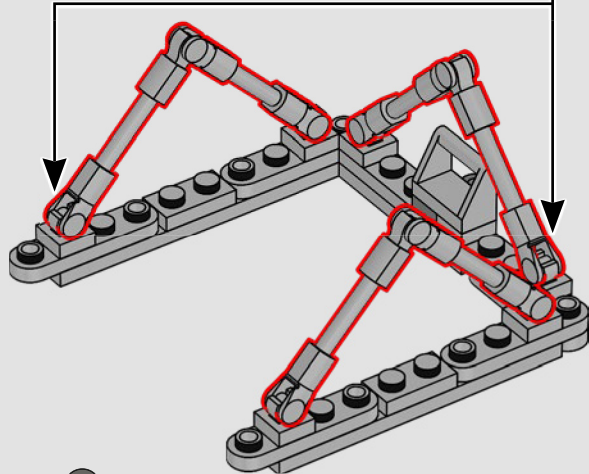
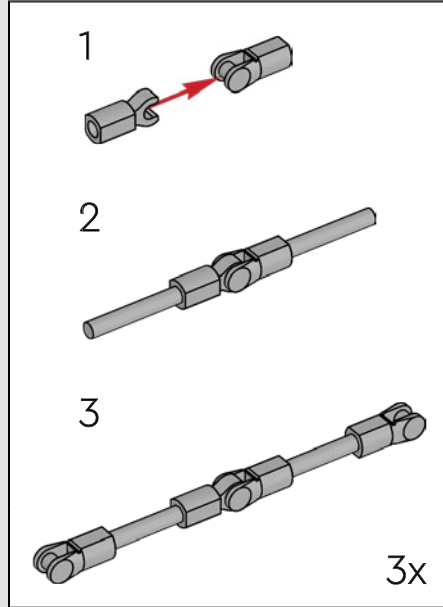

304

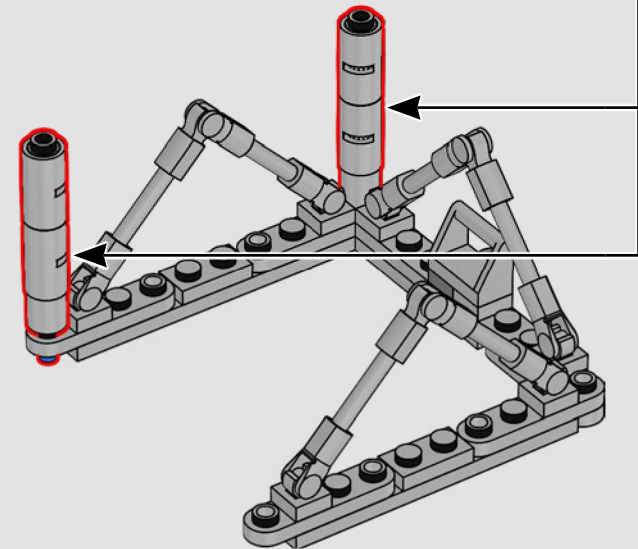
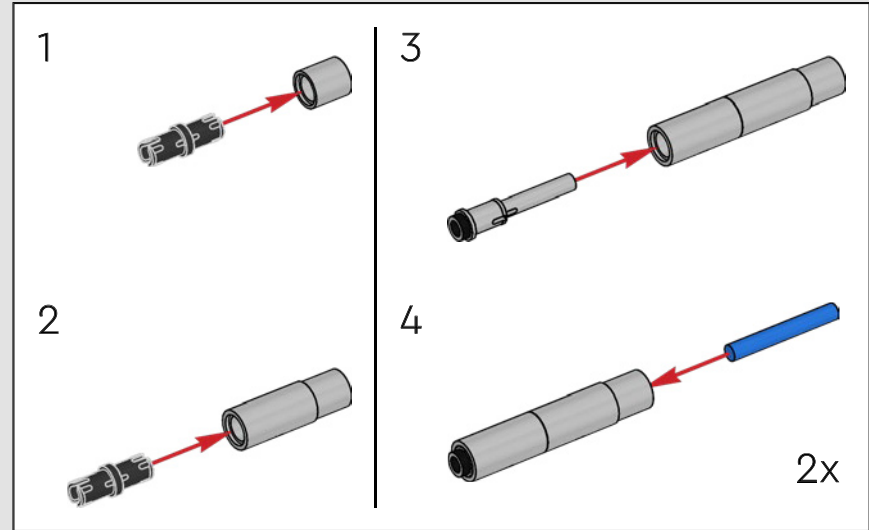

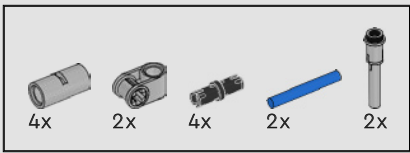

305

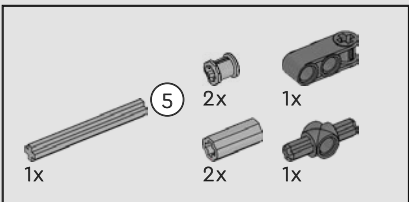
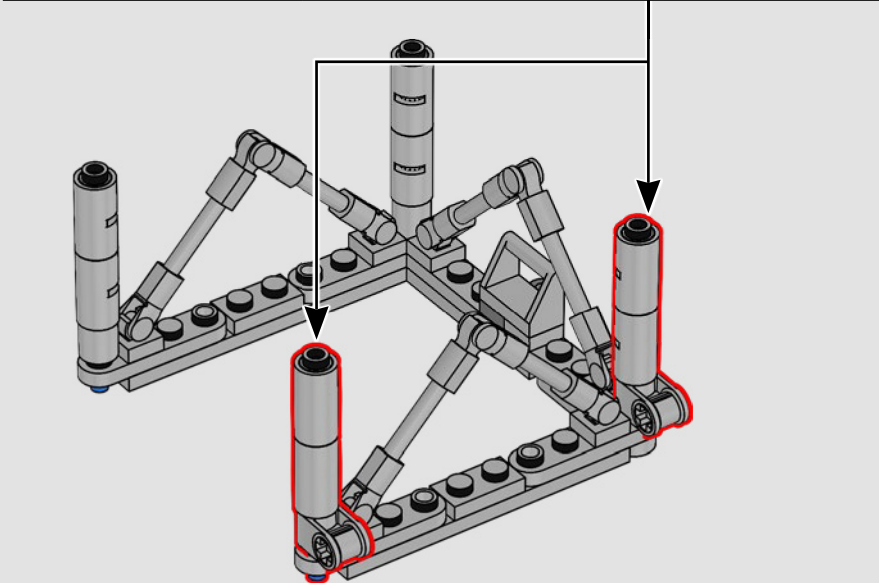
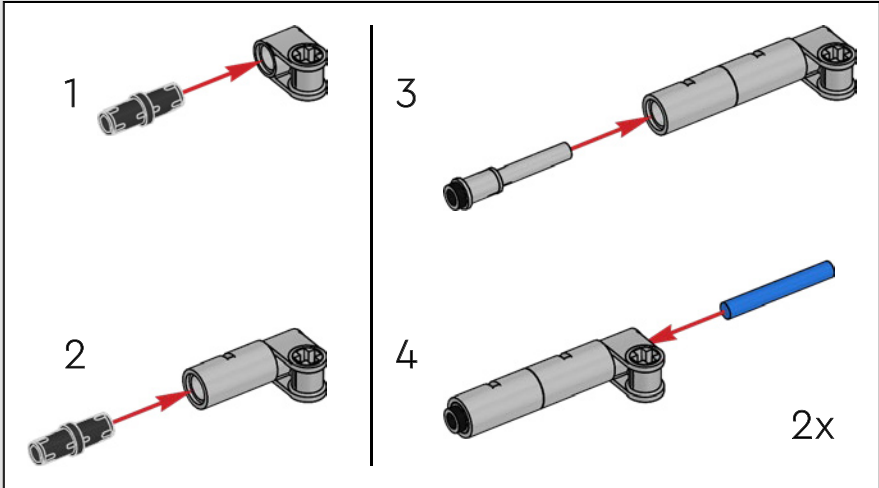

306

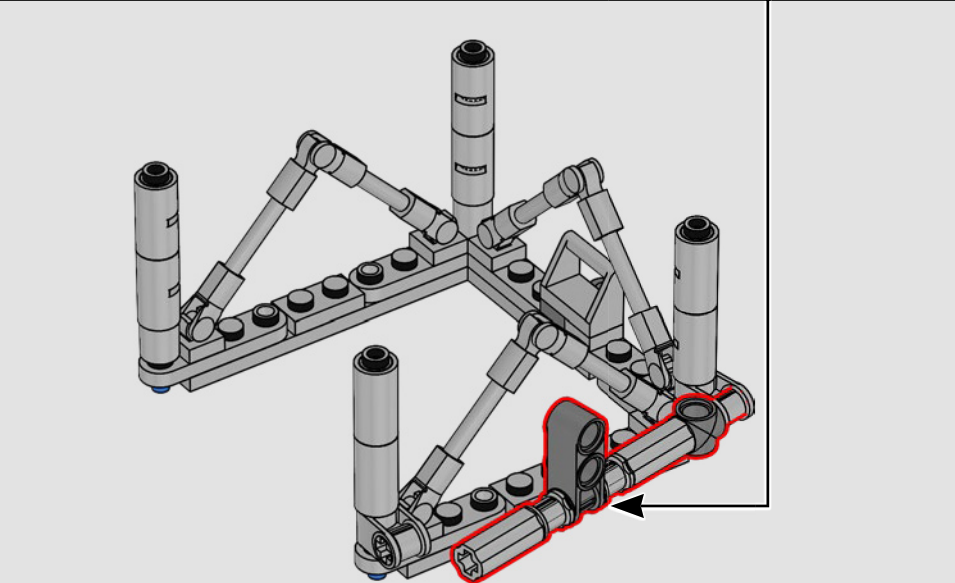
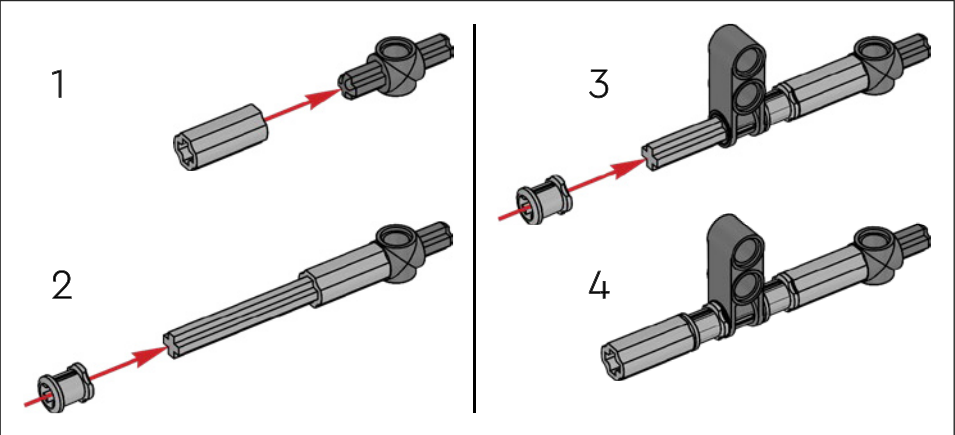
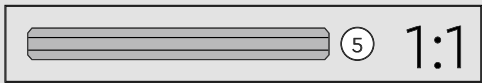

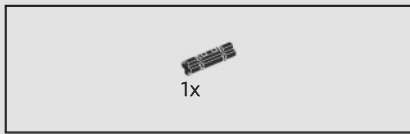

307

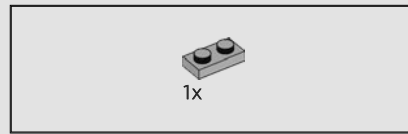
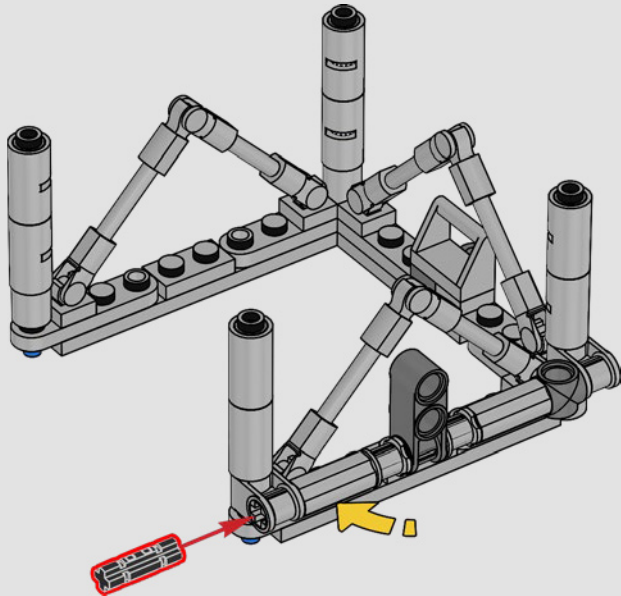

308

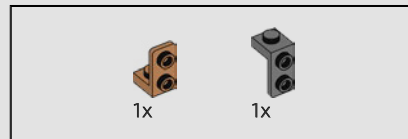
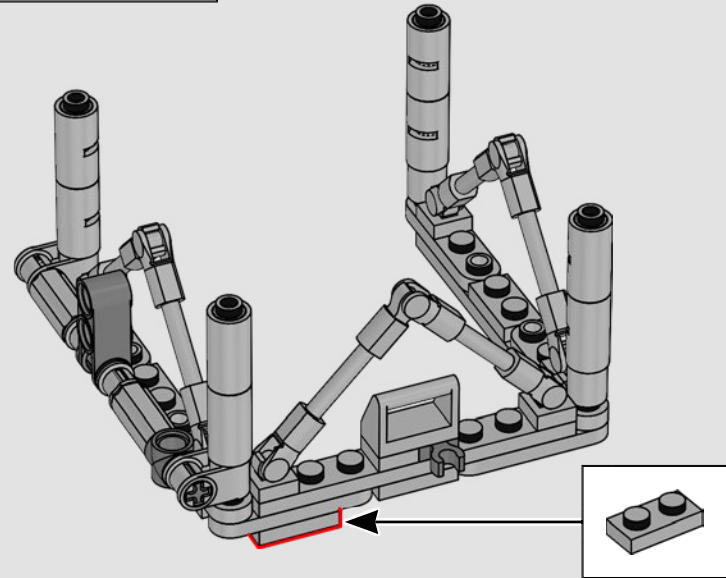
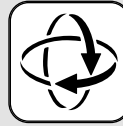

309

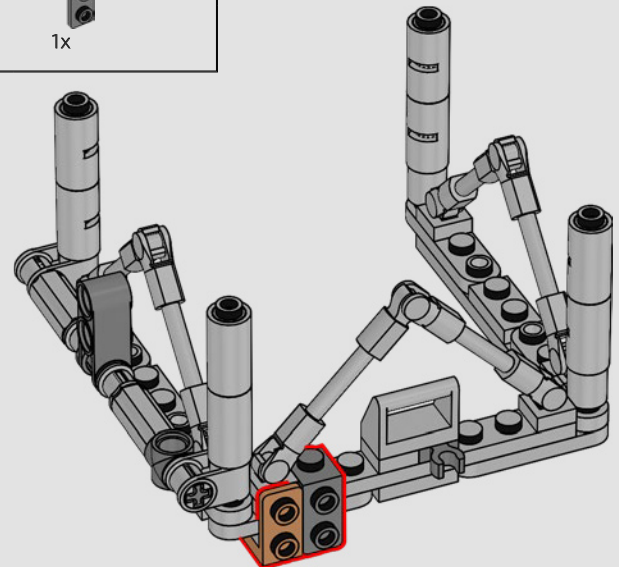

310

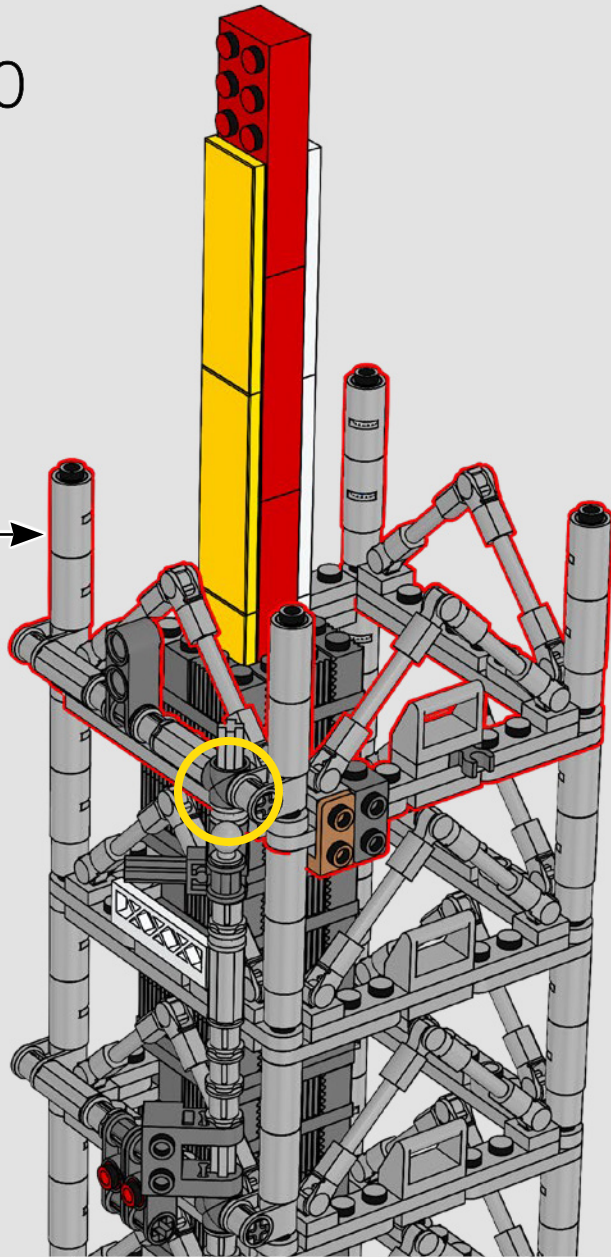

311

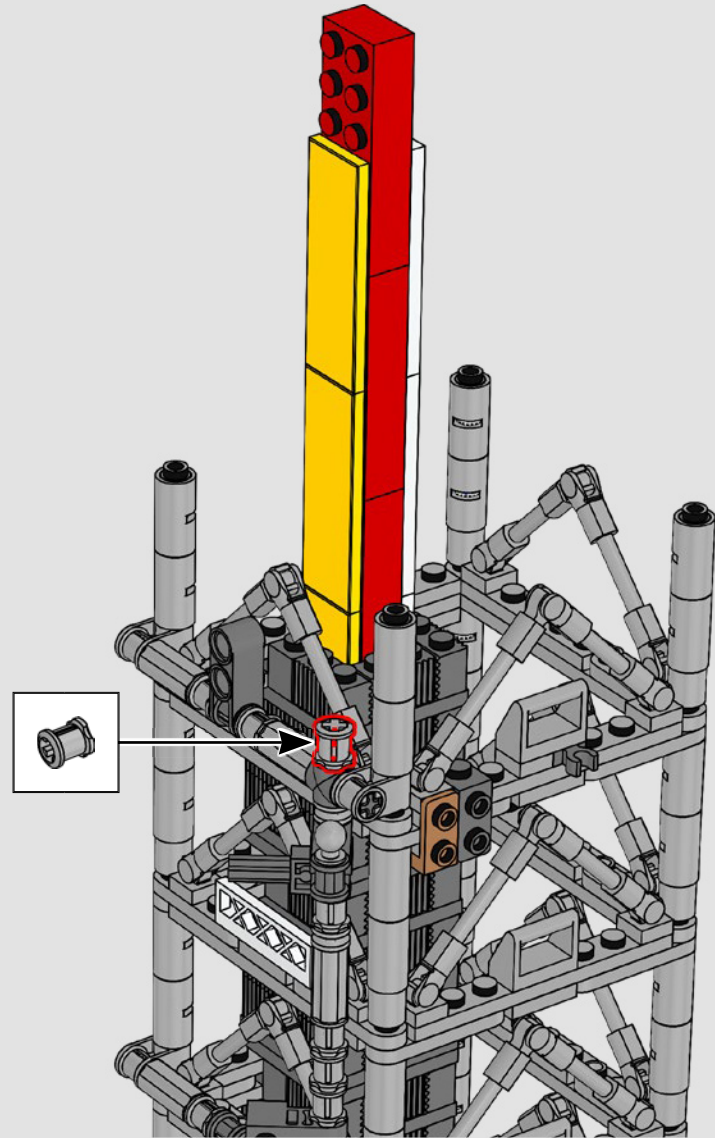
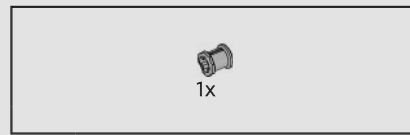

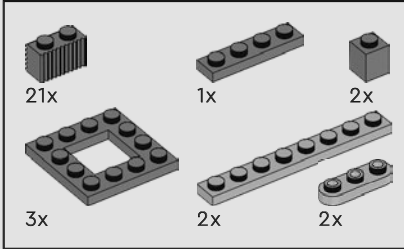
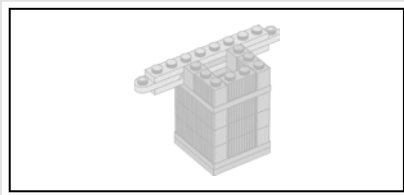

312

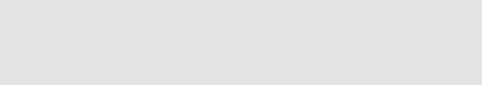
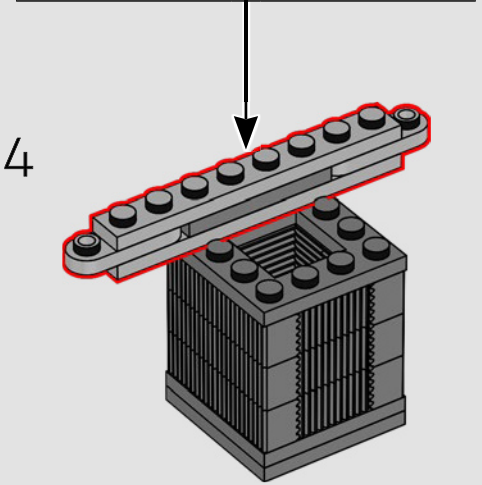
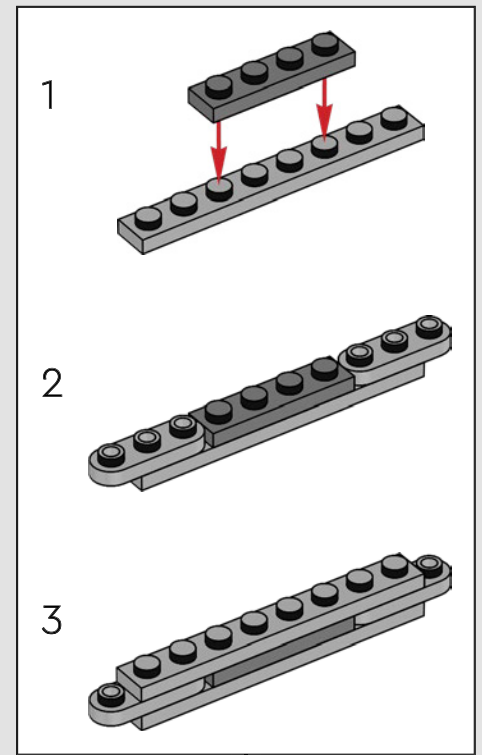
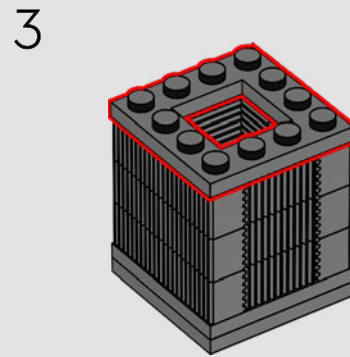
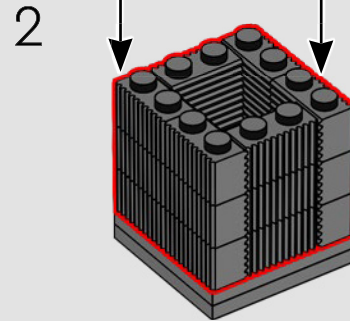
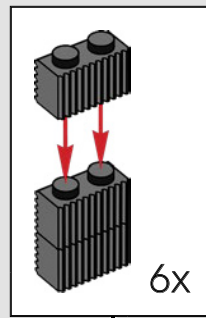
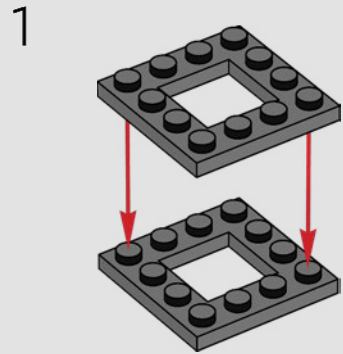

5

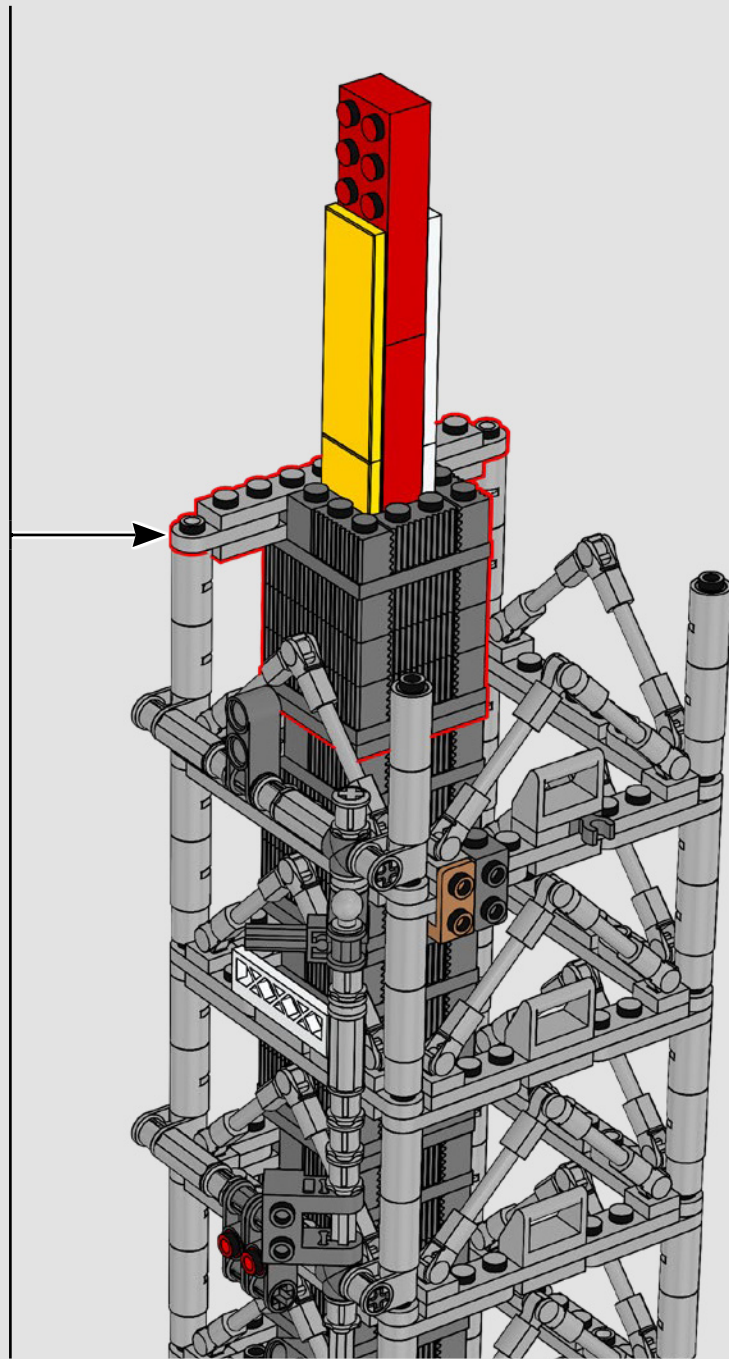
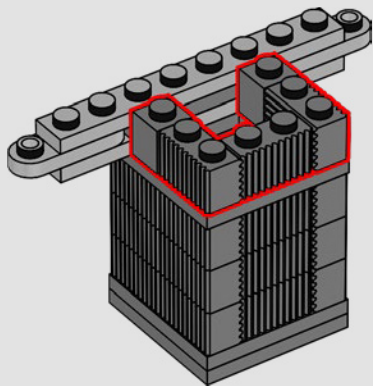

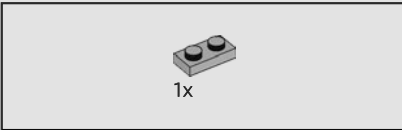
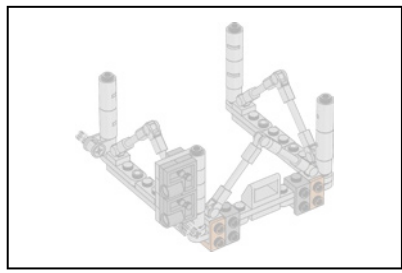

313

1x

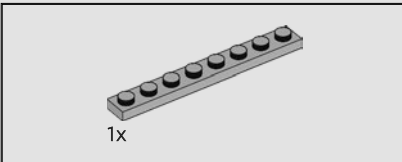
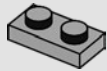

314

1x

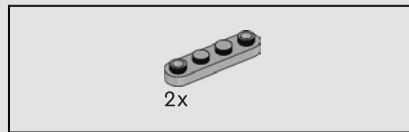
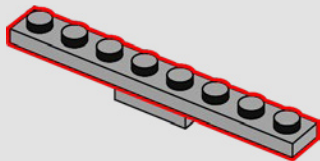

315

2x

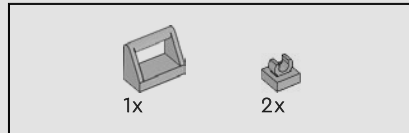
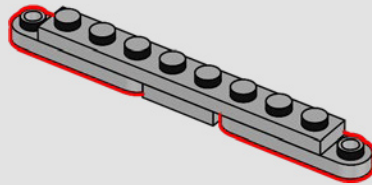

316

1x

2x

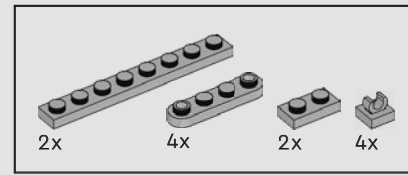
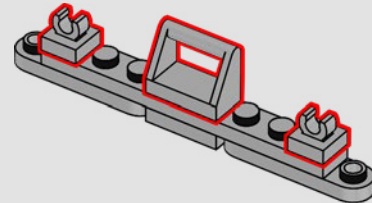

317

2x

4x

2x

4x

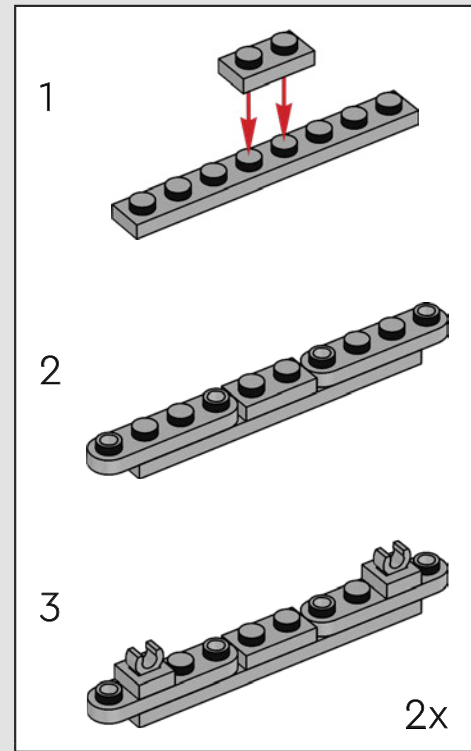

1

2

3

2x

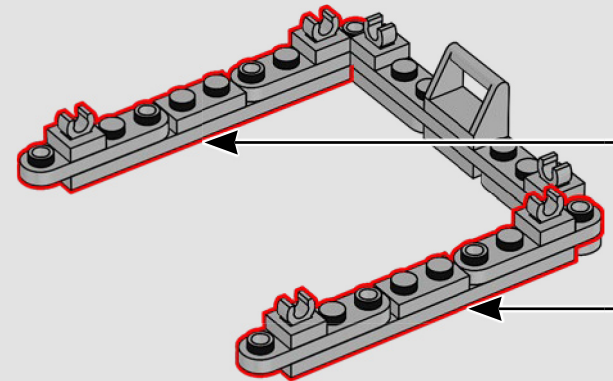

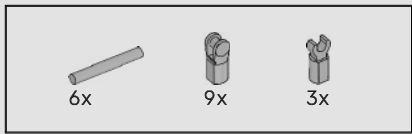

318

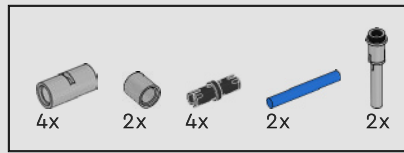
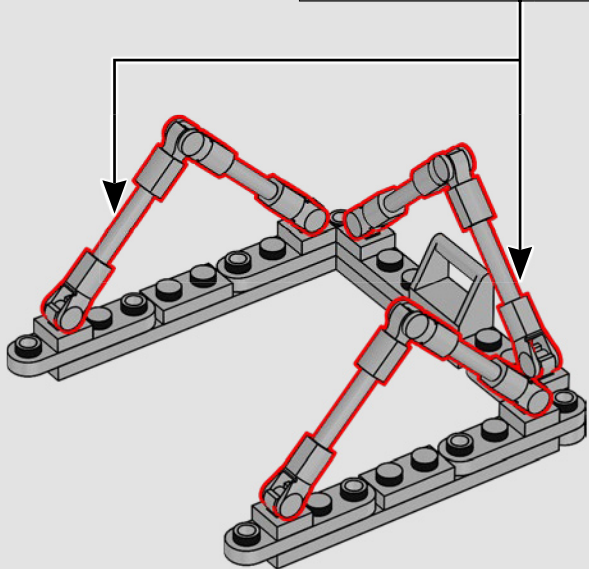
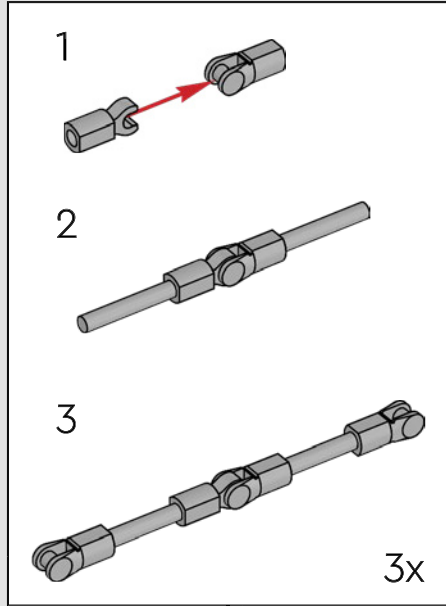

319

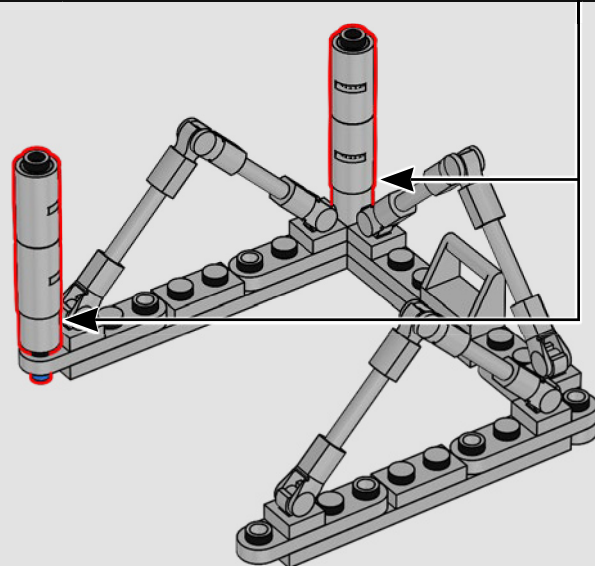
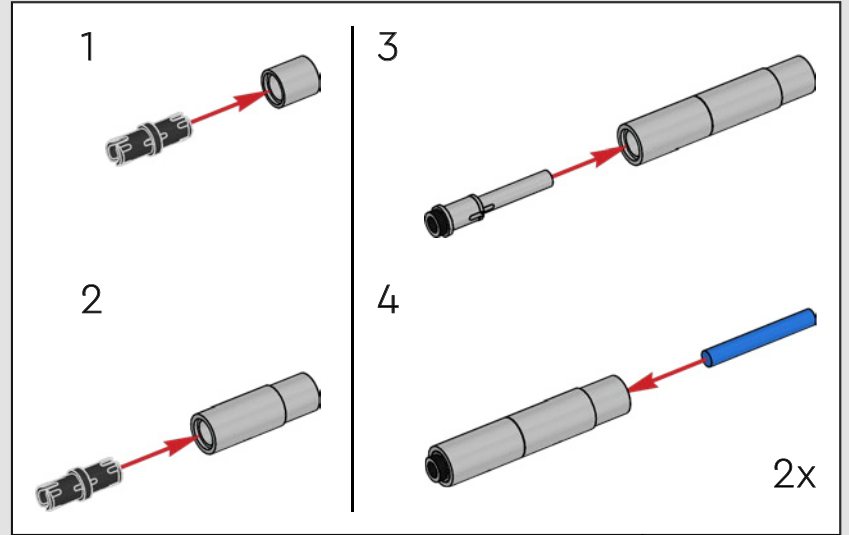

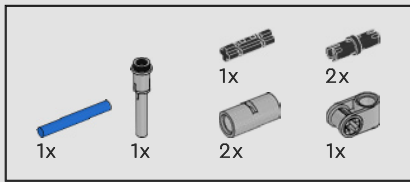

320

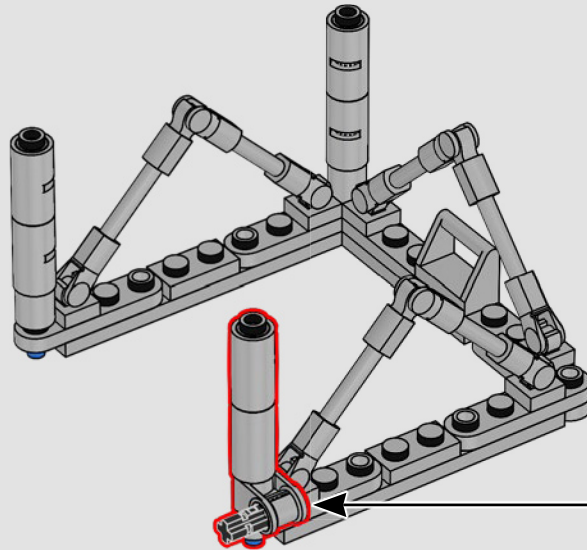
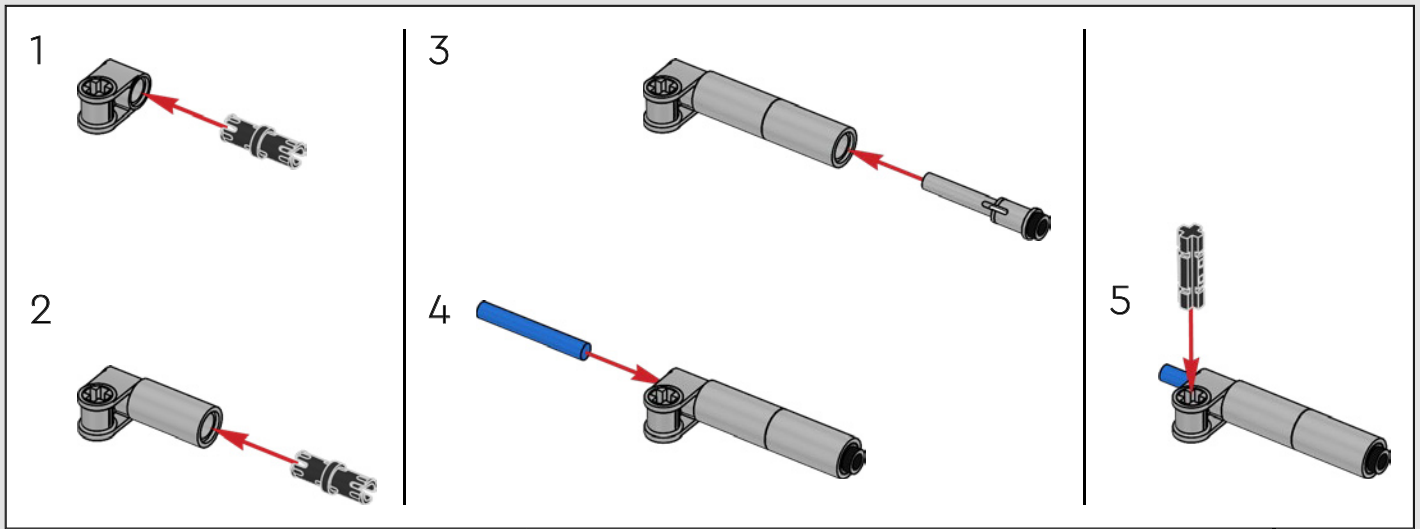

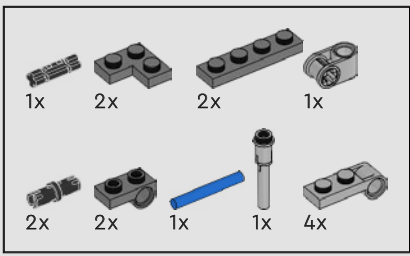

321

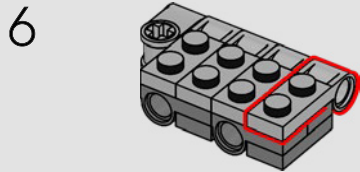
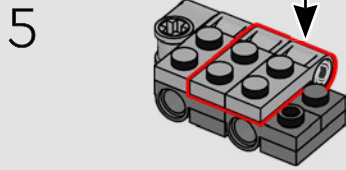
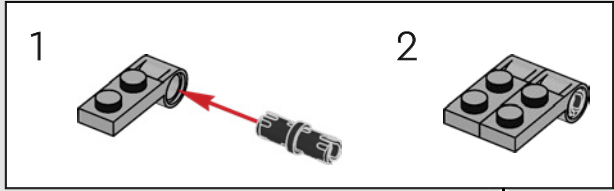
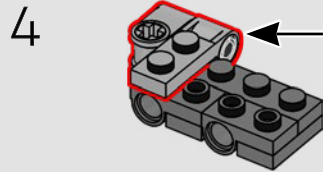
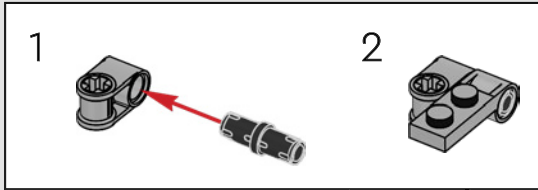
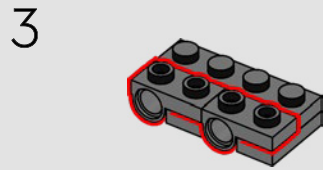
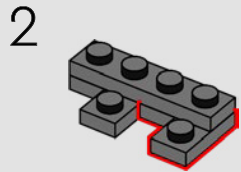
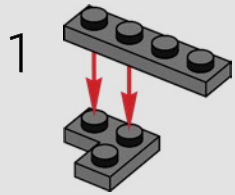

7

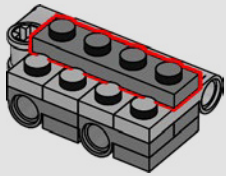

8

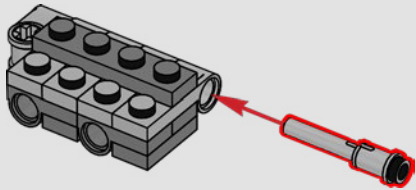

9

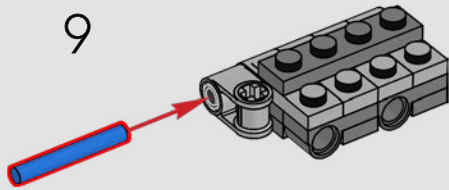

10

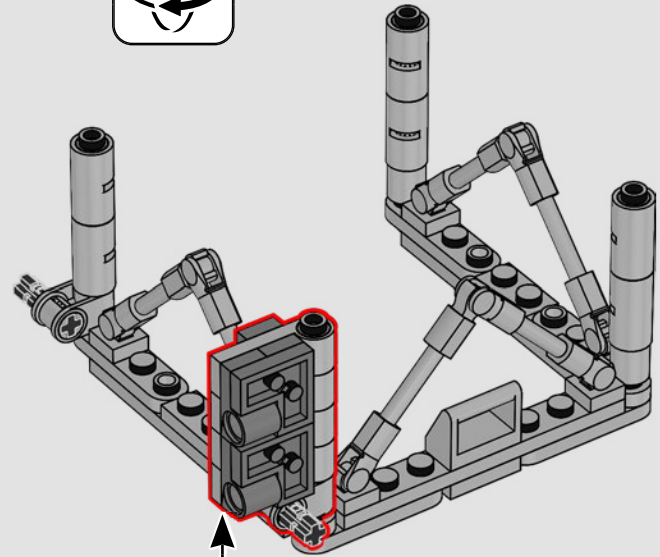
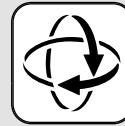
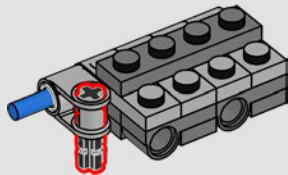



2x

322

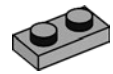
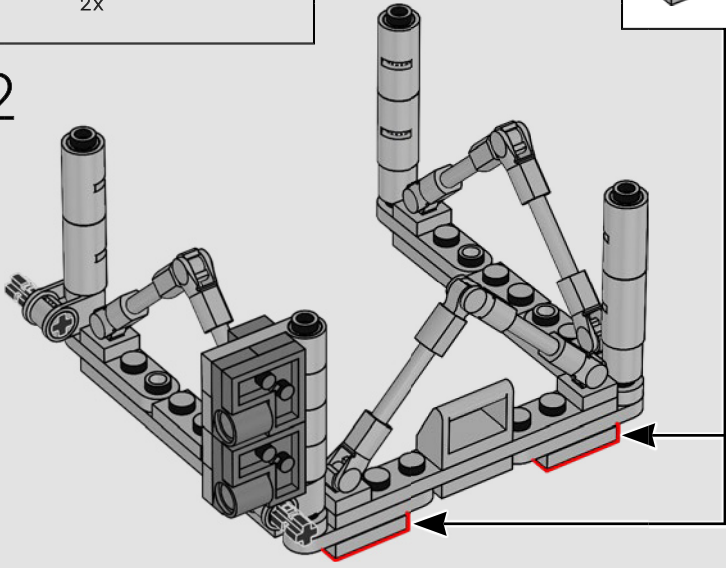

2x

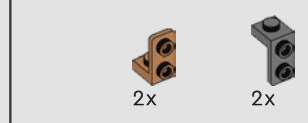

2x

2x

323

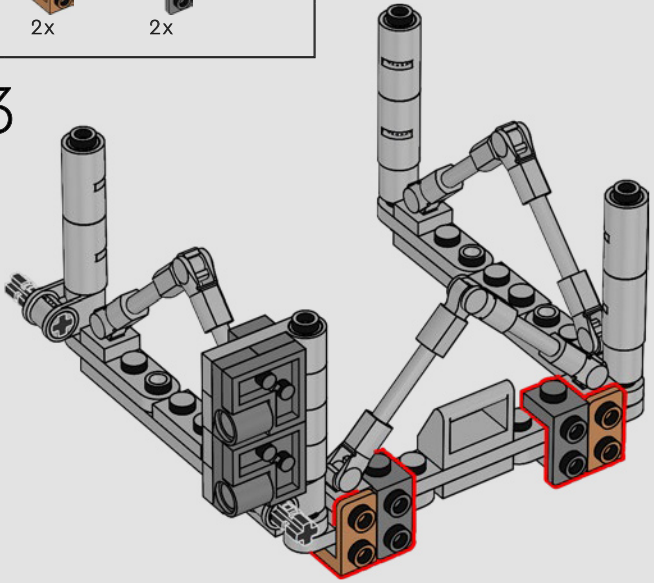

324

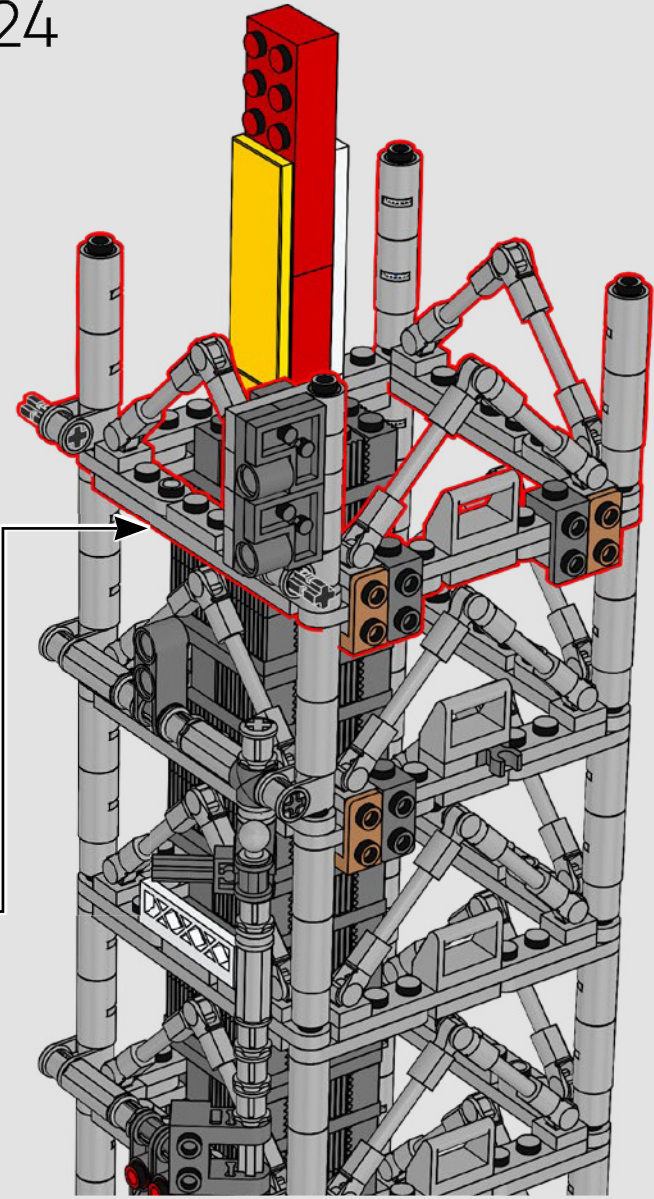

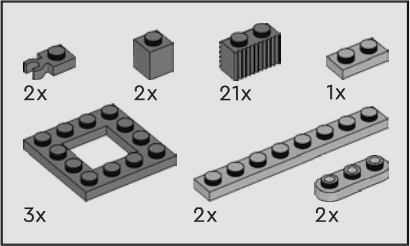
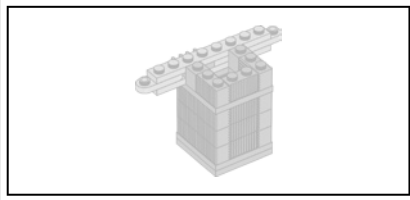

325

1

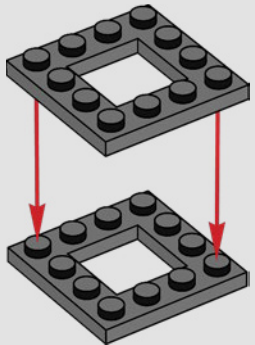

2

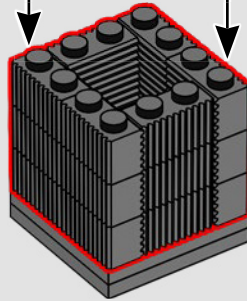

3

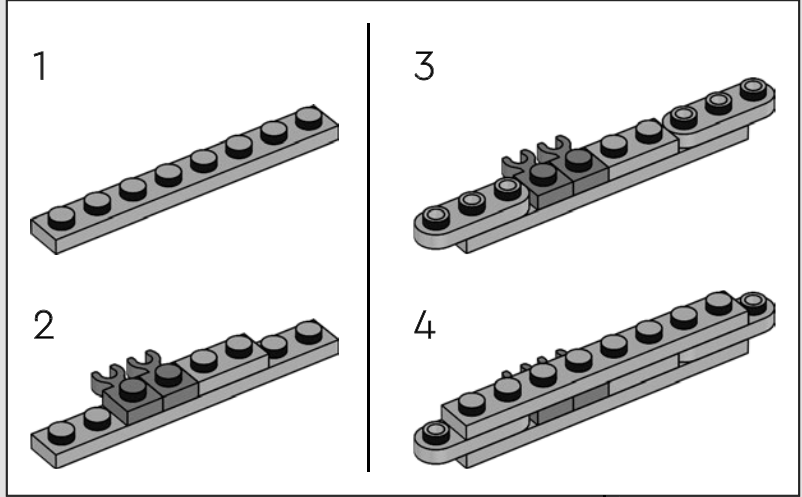
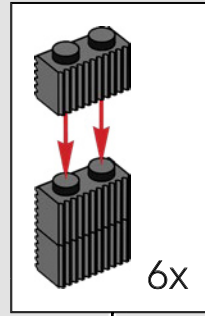
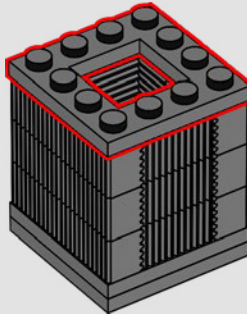

4

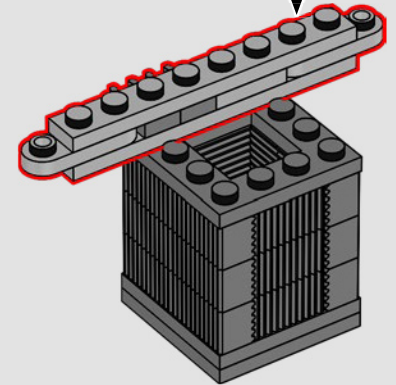

5

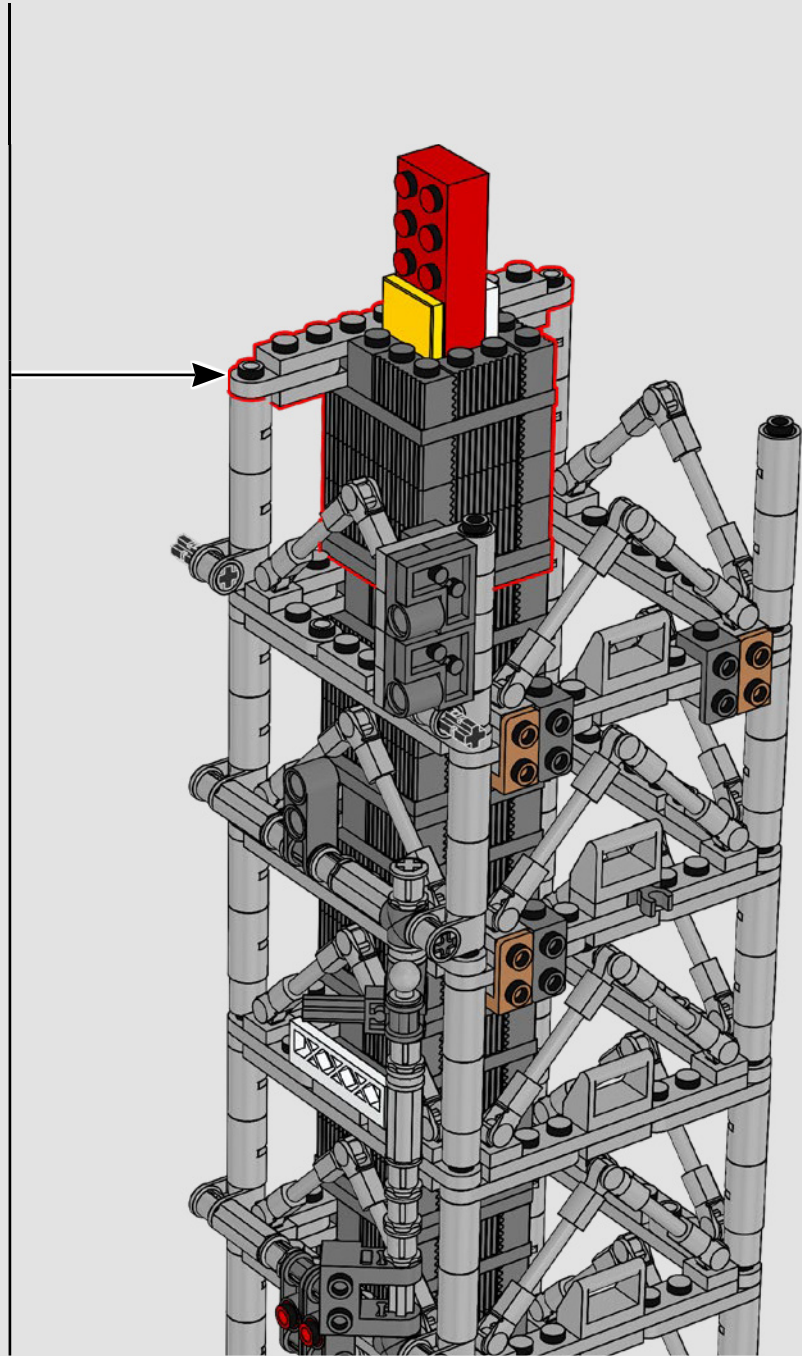
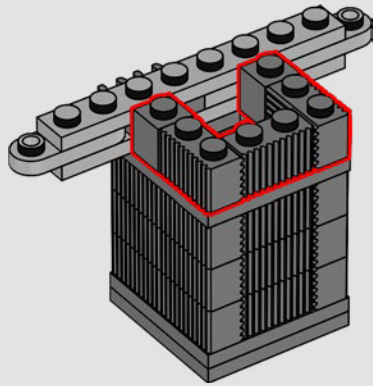

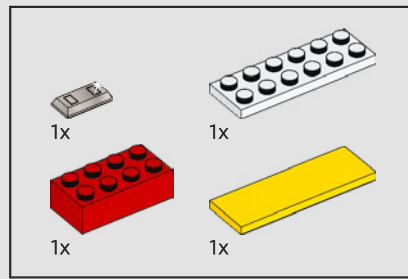

326

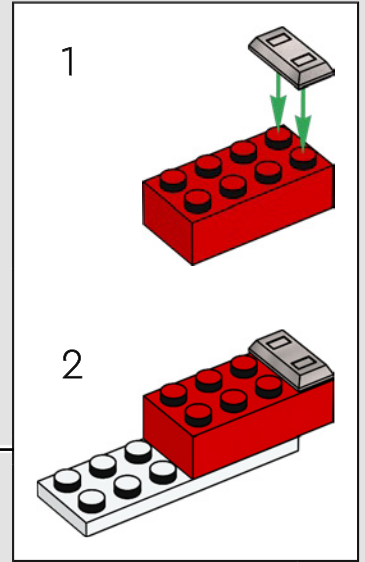
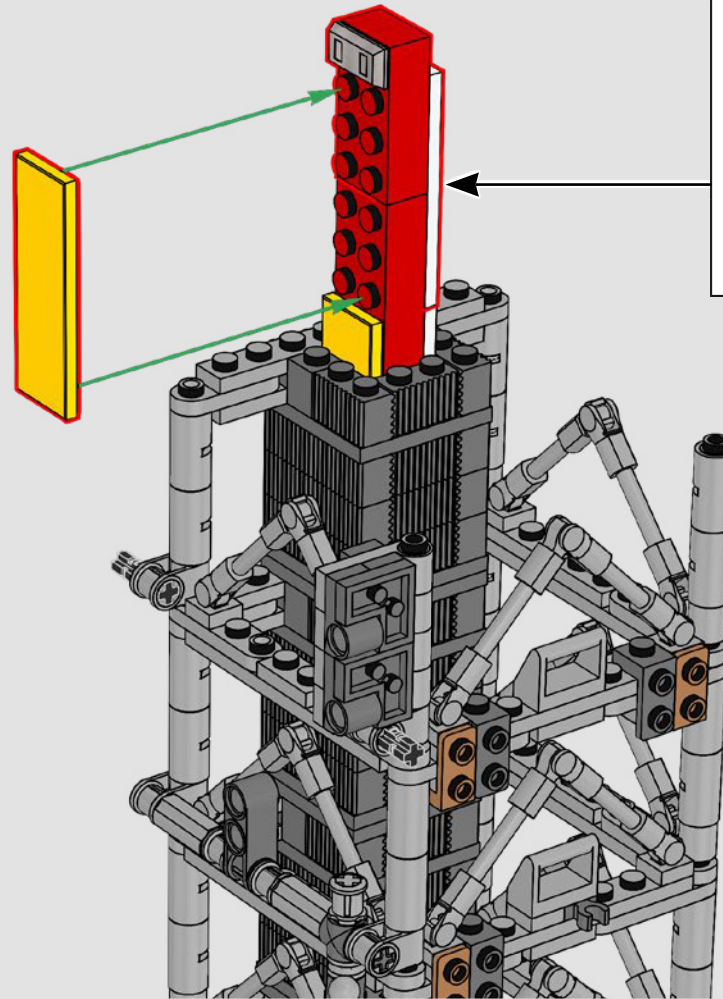

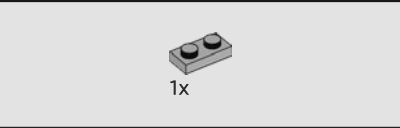
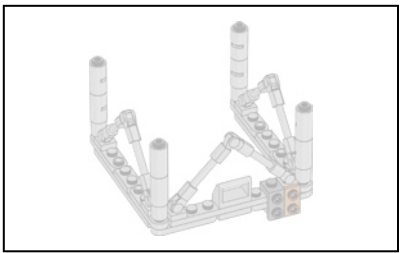

327

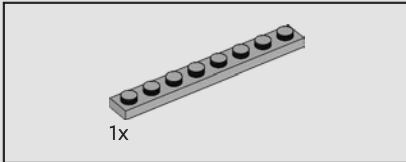

328

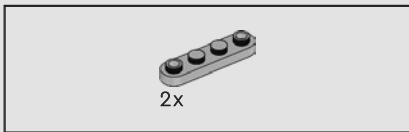
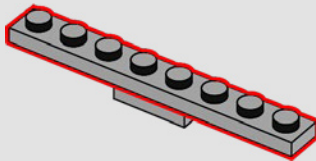

329

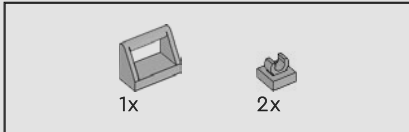
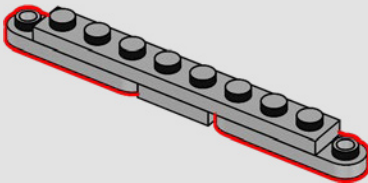

330

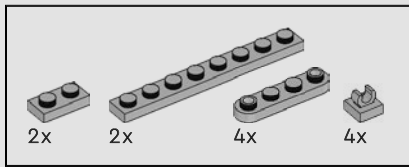
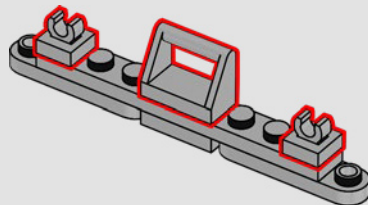

331

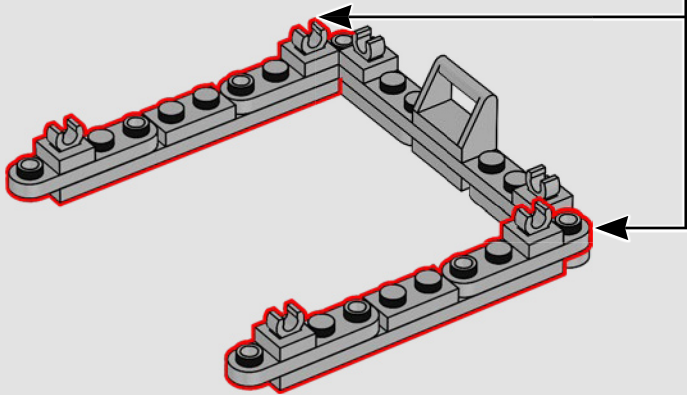
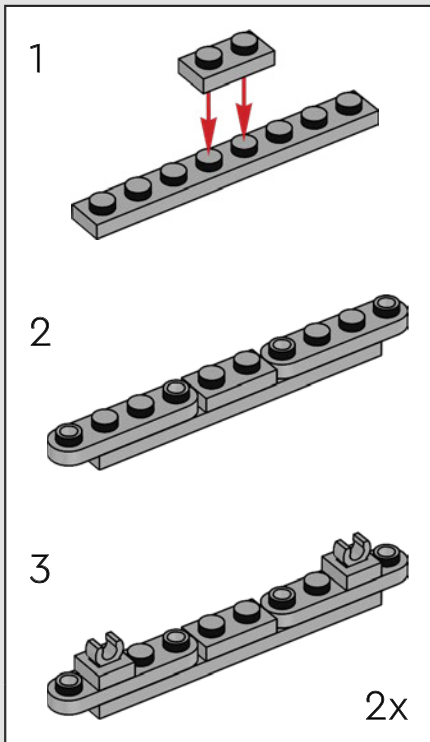

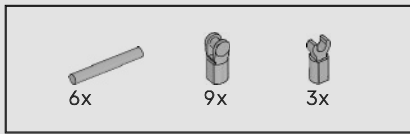

332

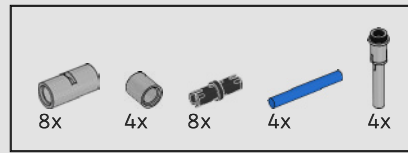
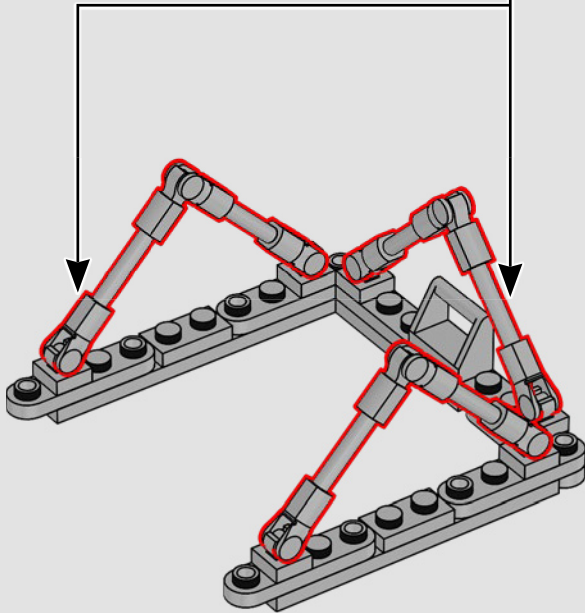
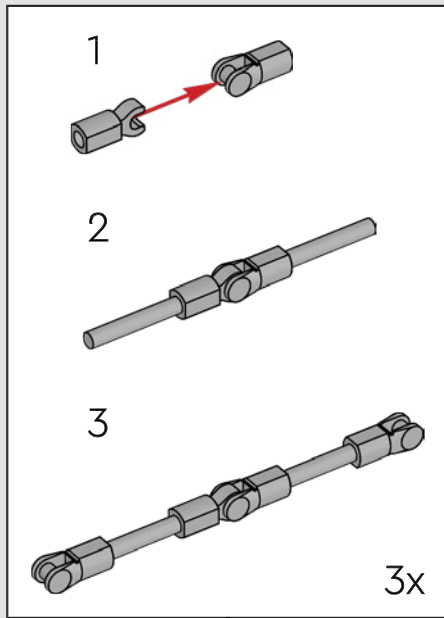

333

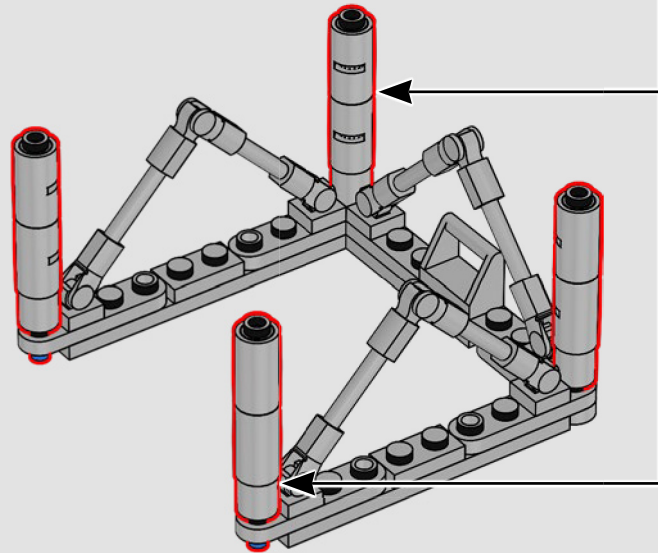
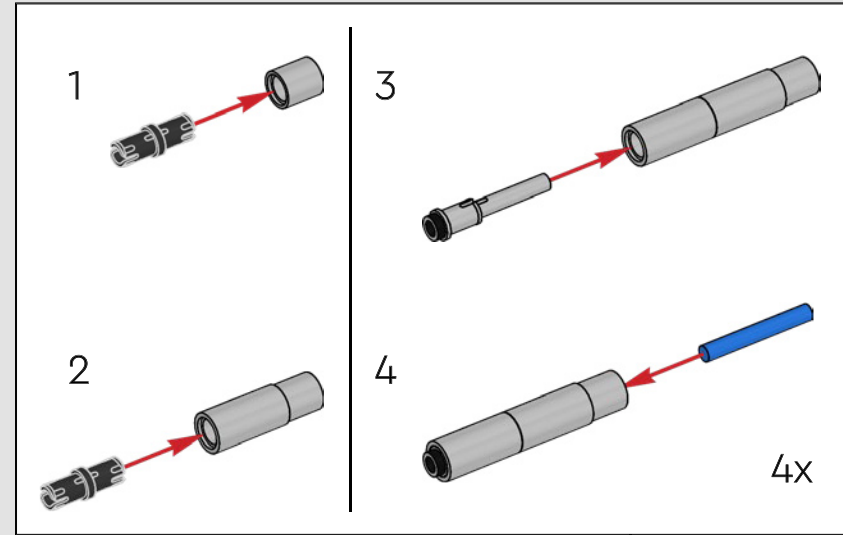



1x

334

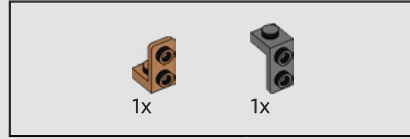
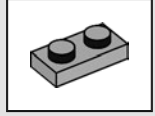
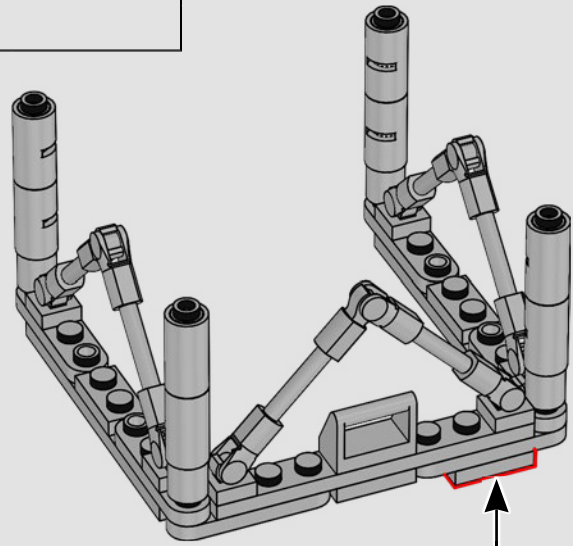

1x

1x

335

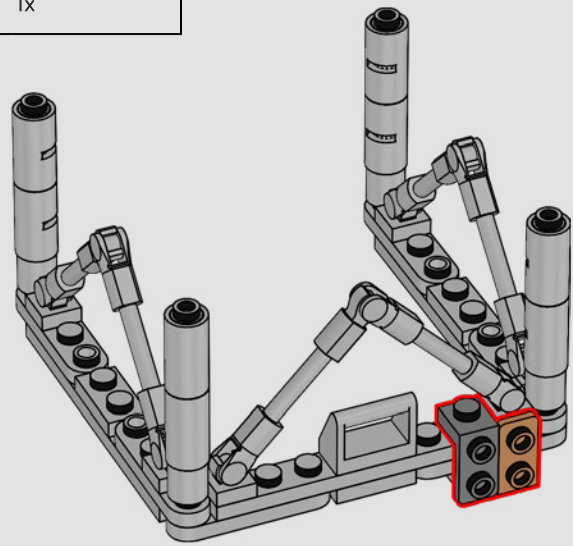

336

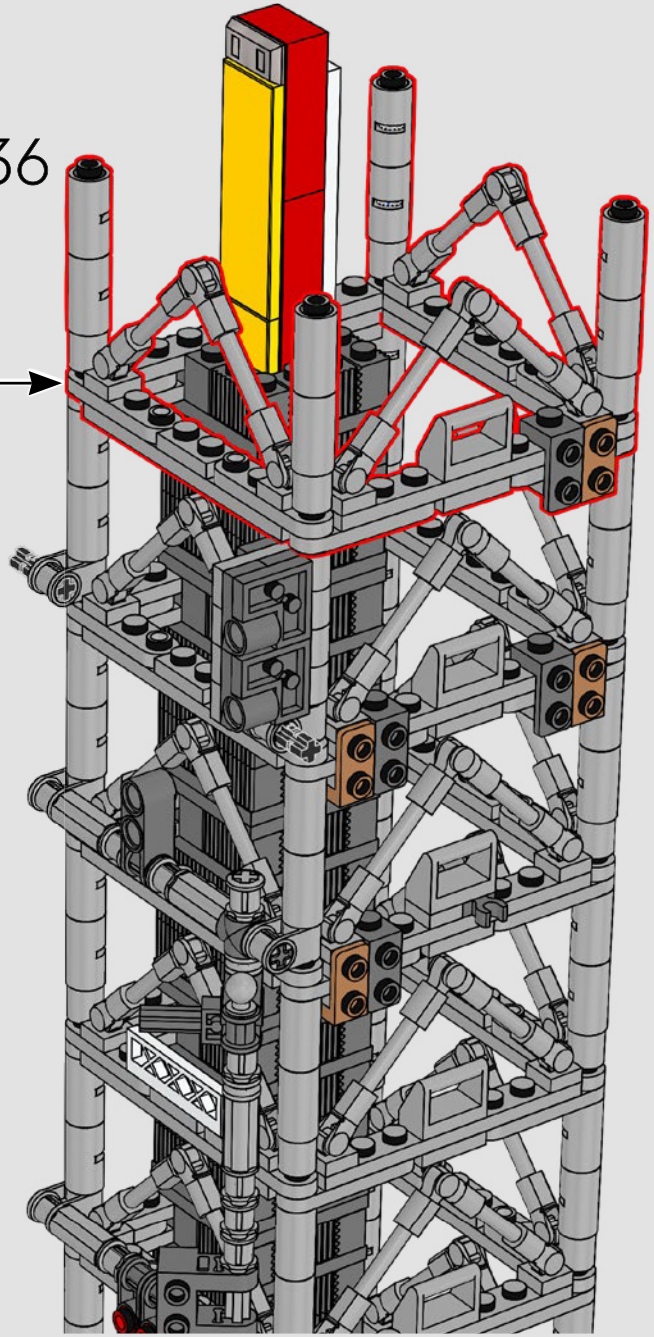

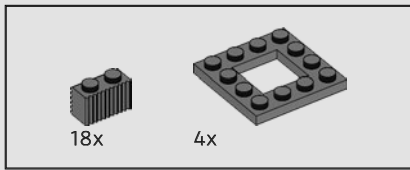

337

1

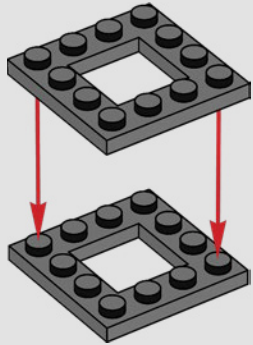

2

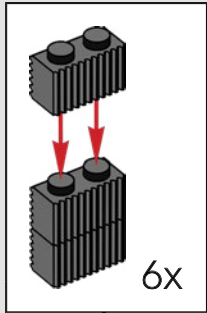

6x

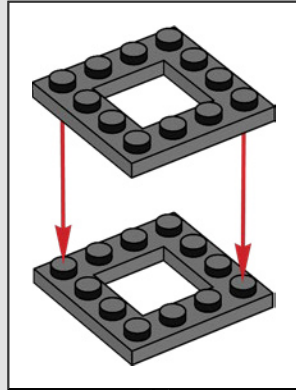
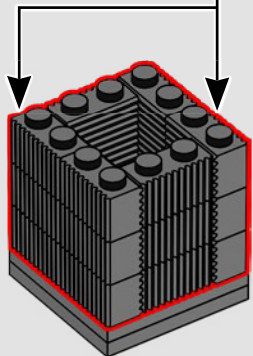

3

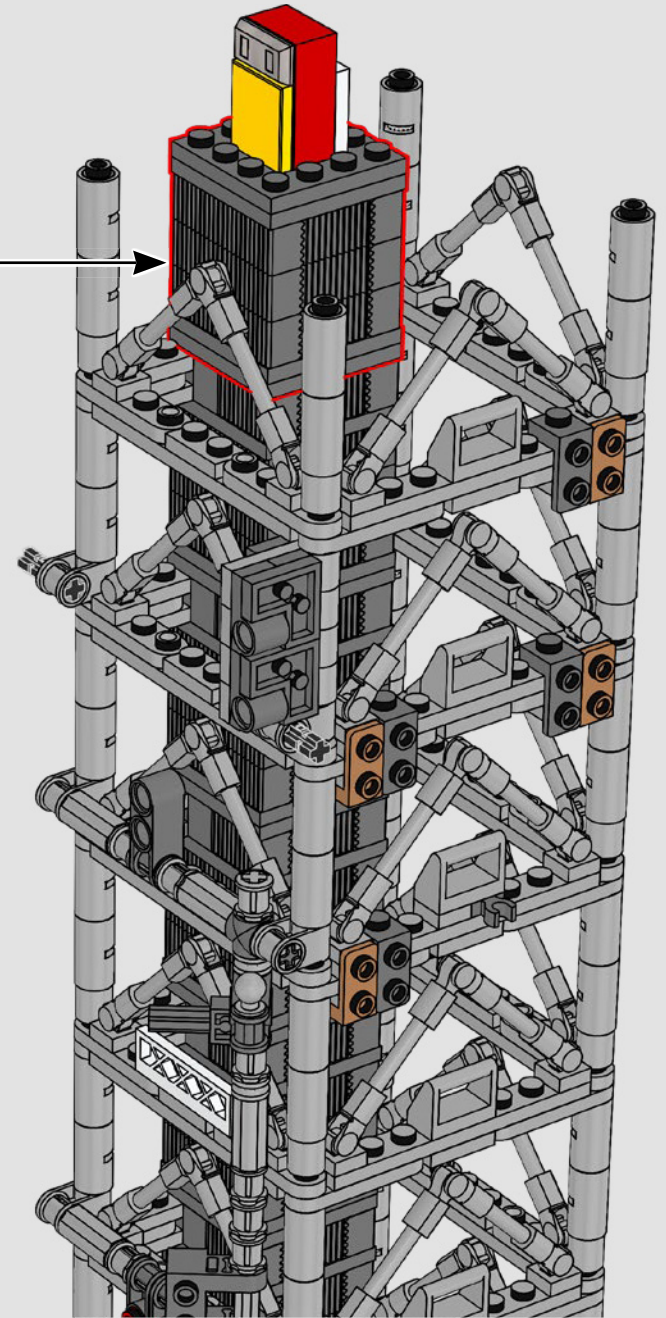
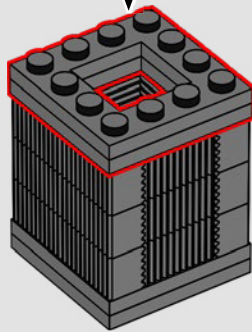

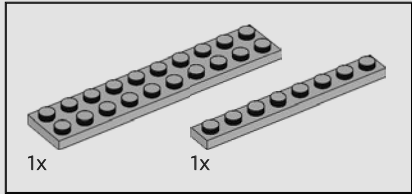
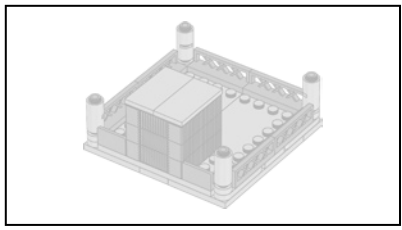

338

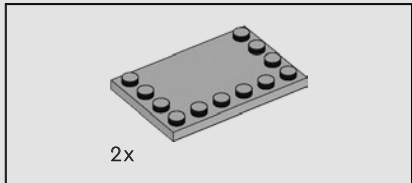
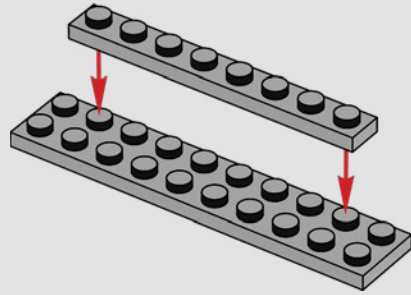

339

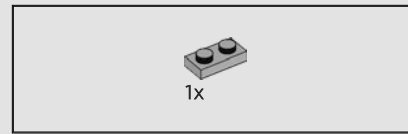
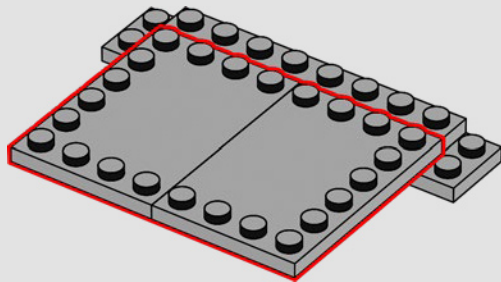

340

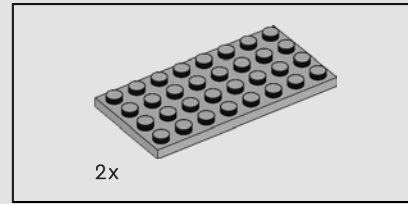
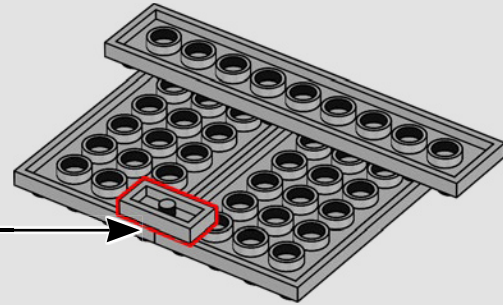
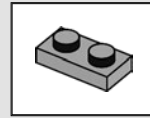
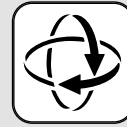

341

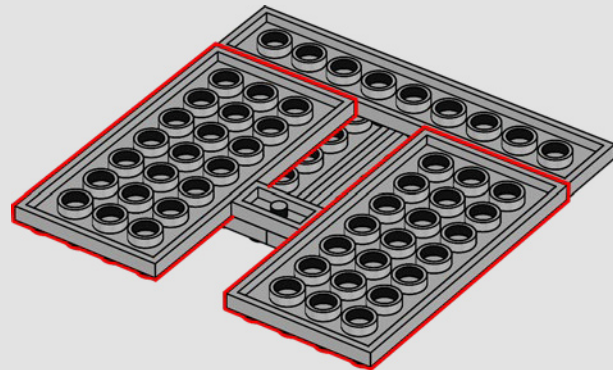

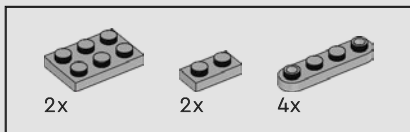

342

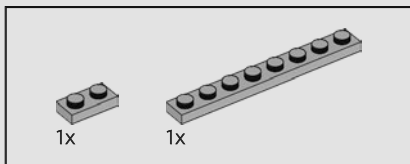
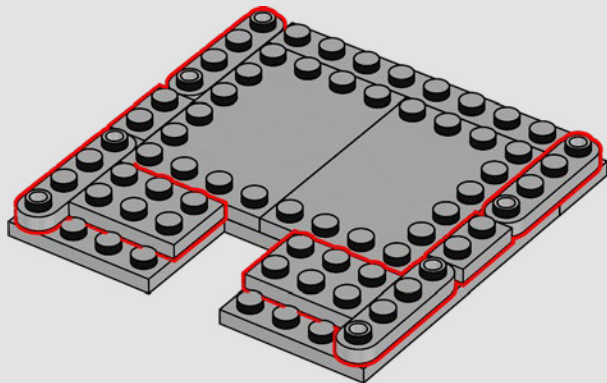
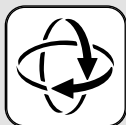

343

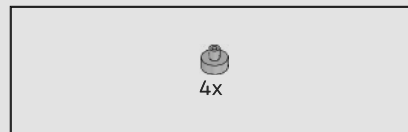
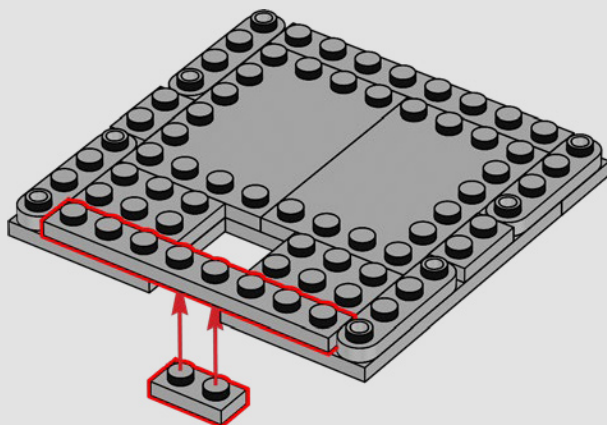

344

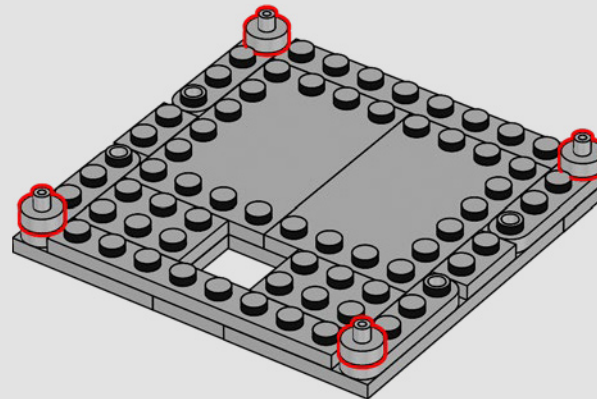

345

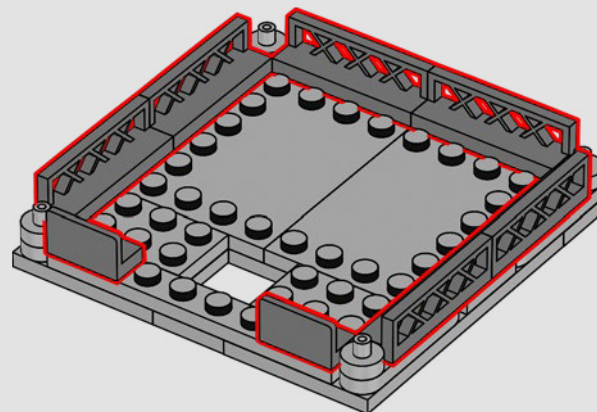



5x

346

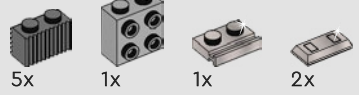
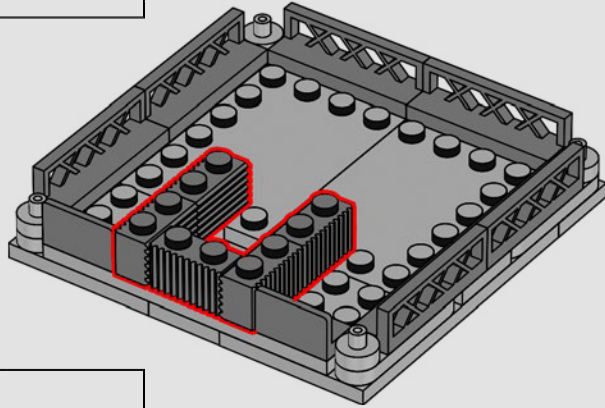

347

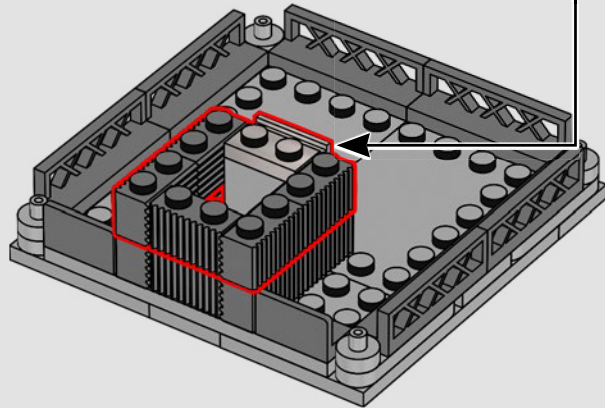
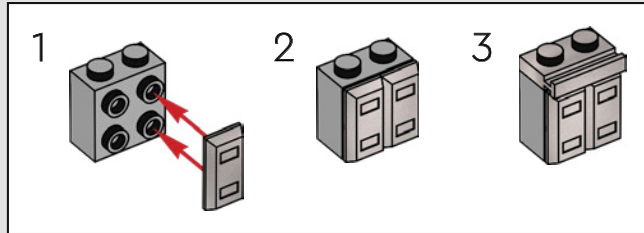

6x

348

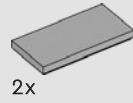
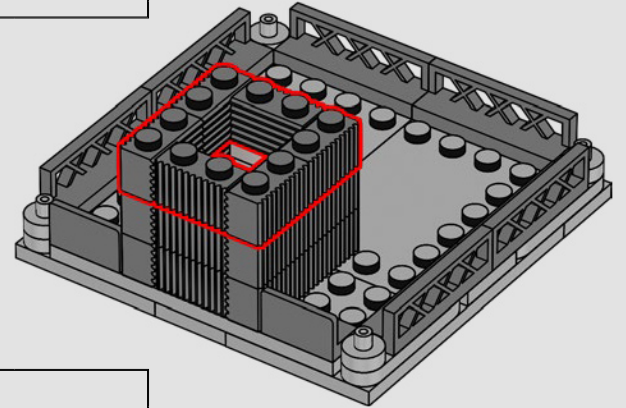

2x

349

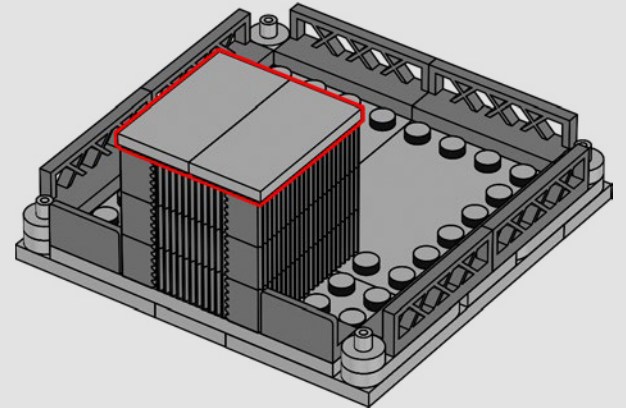

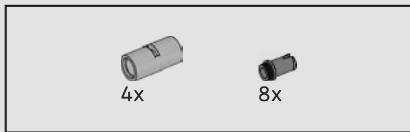

350

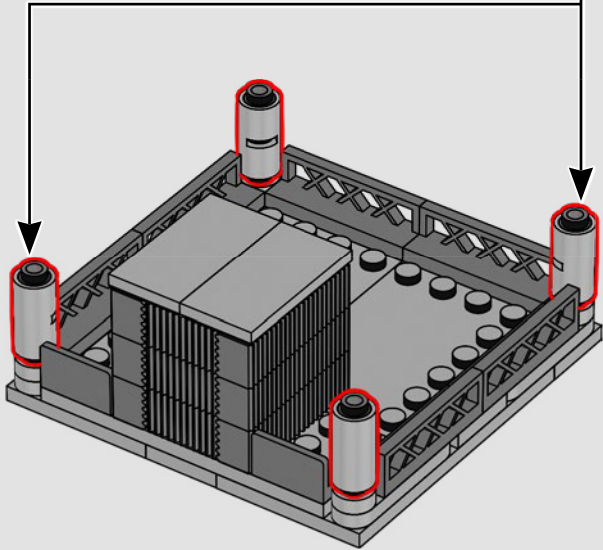
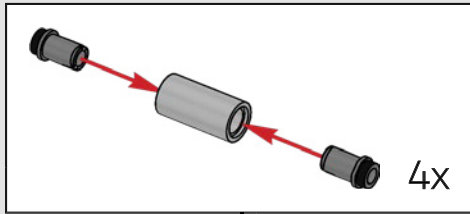

351

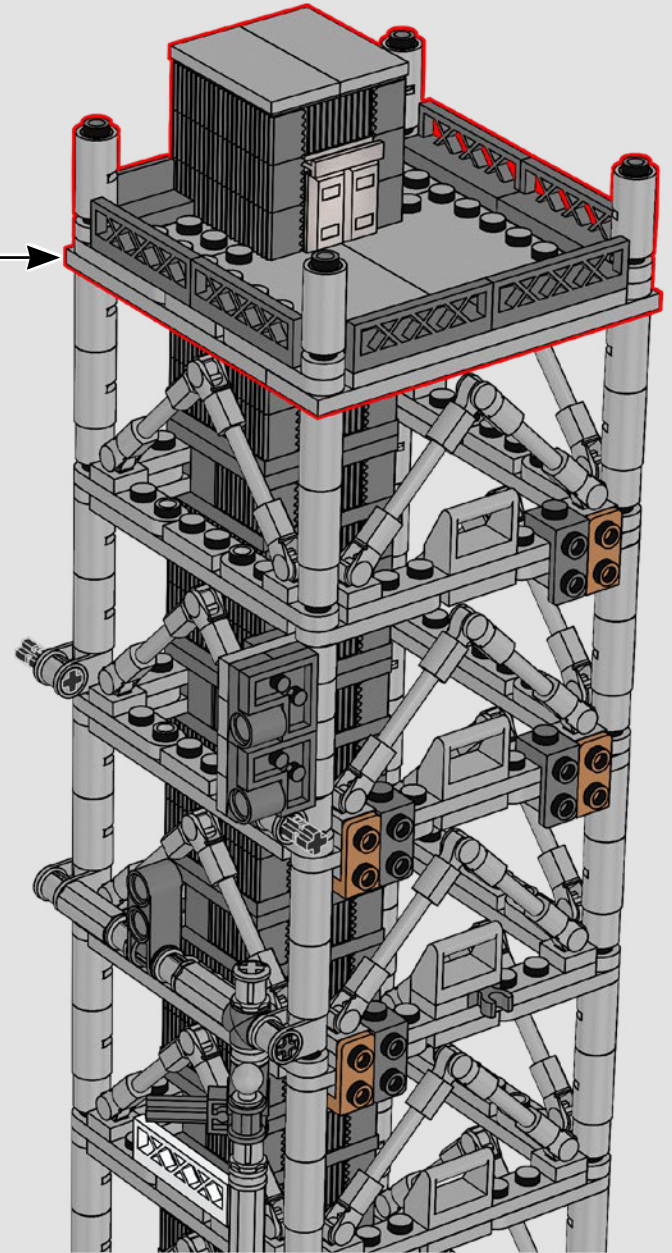

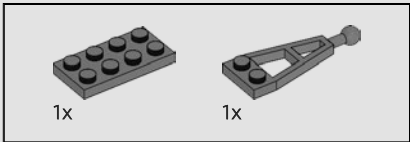
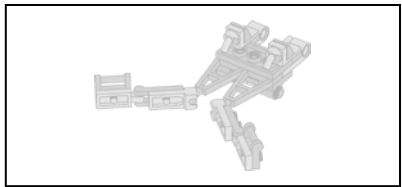

352

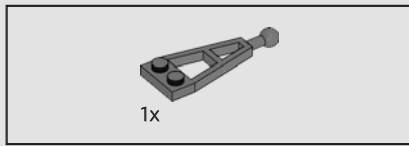
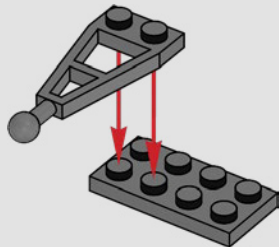

353

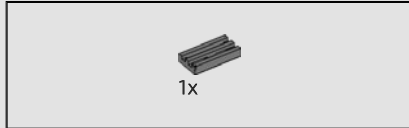
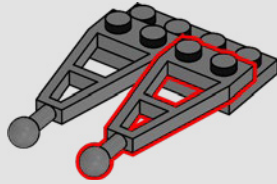

354

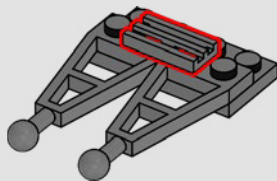

355

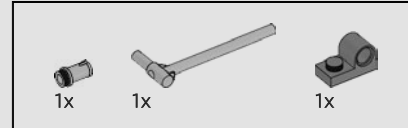
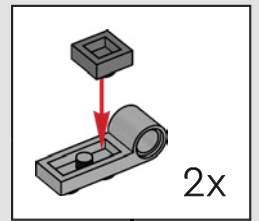
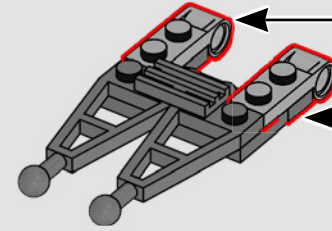

356

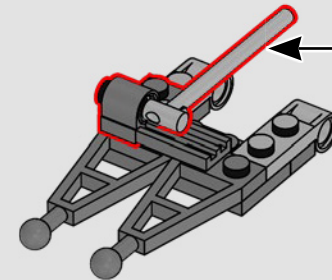
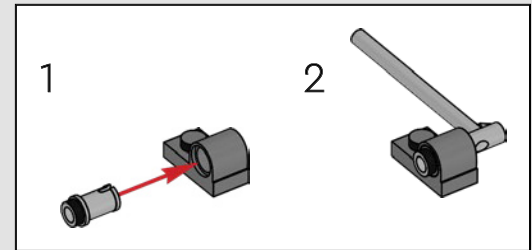

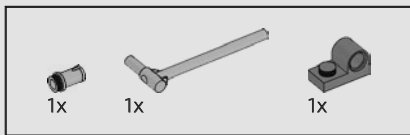

357

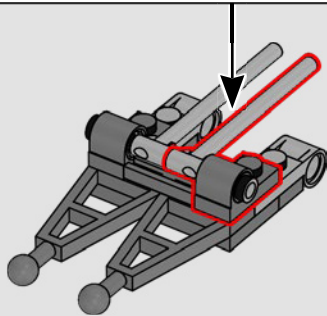
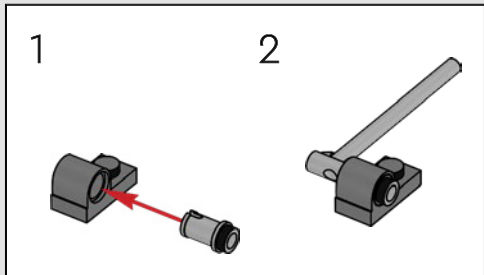

358

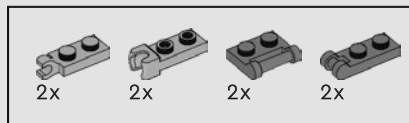
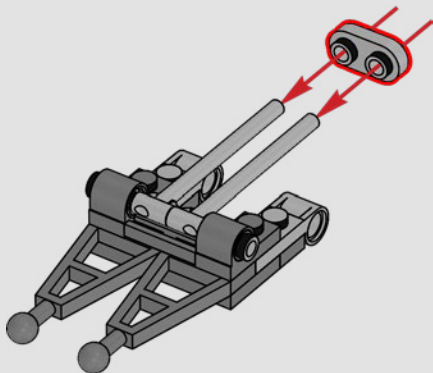

359

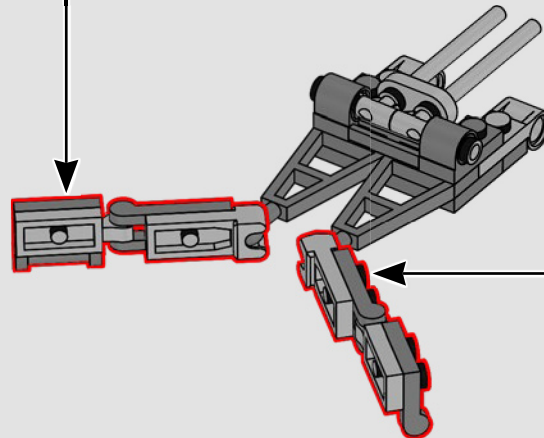
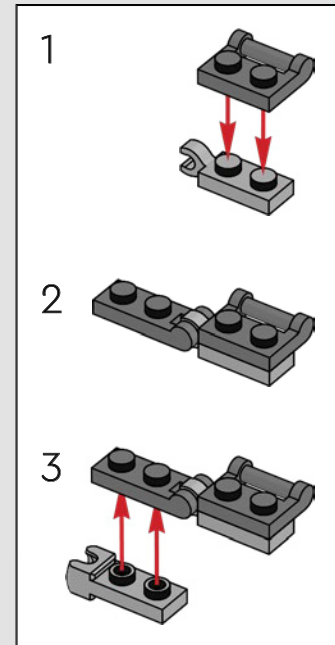
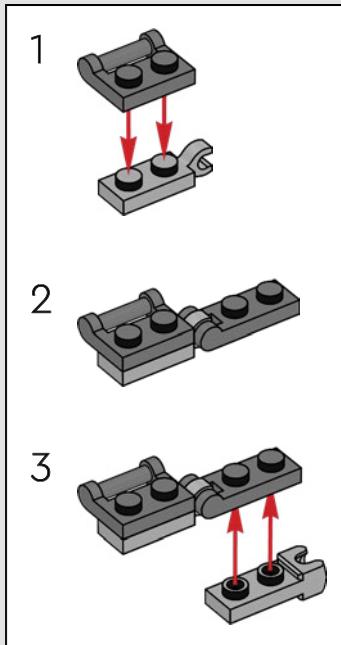



360

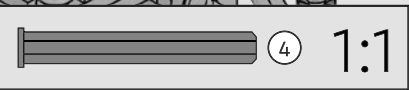
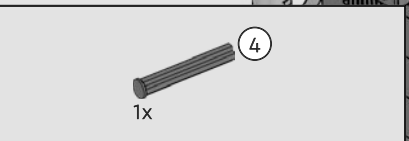
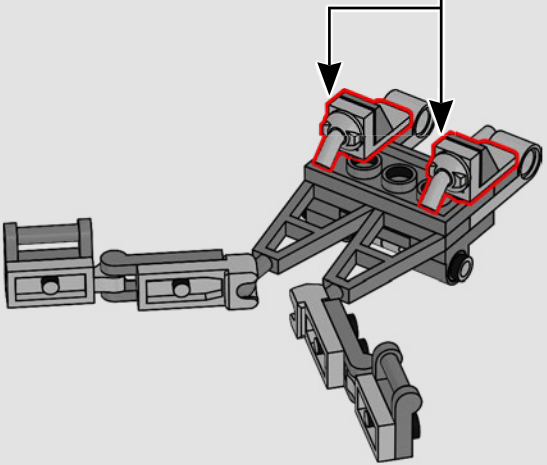
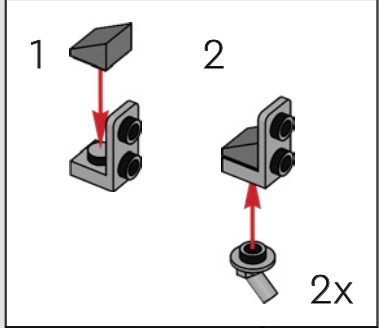

361

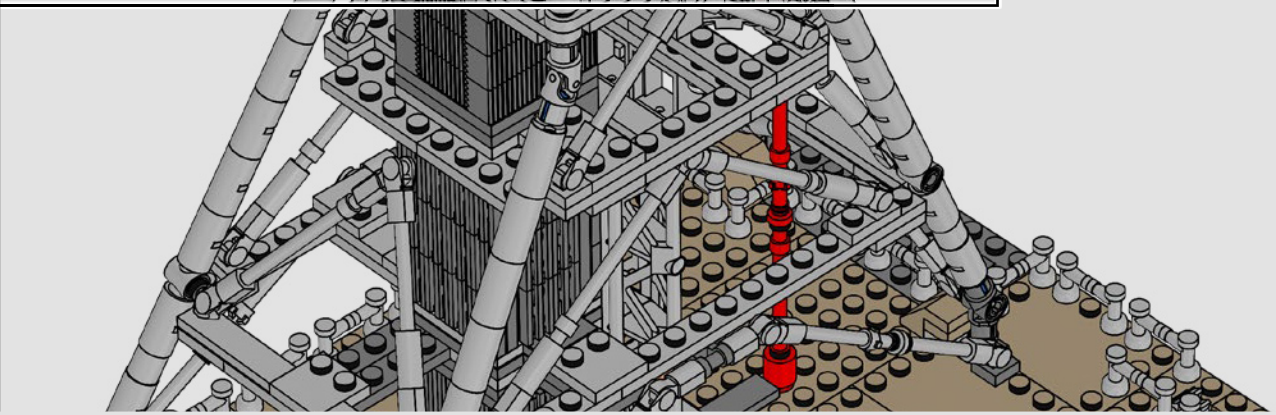
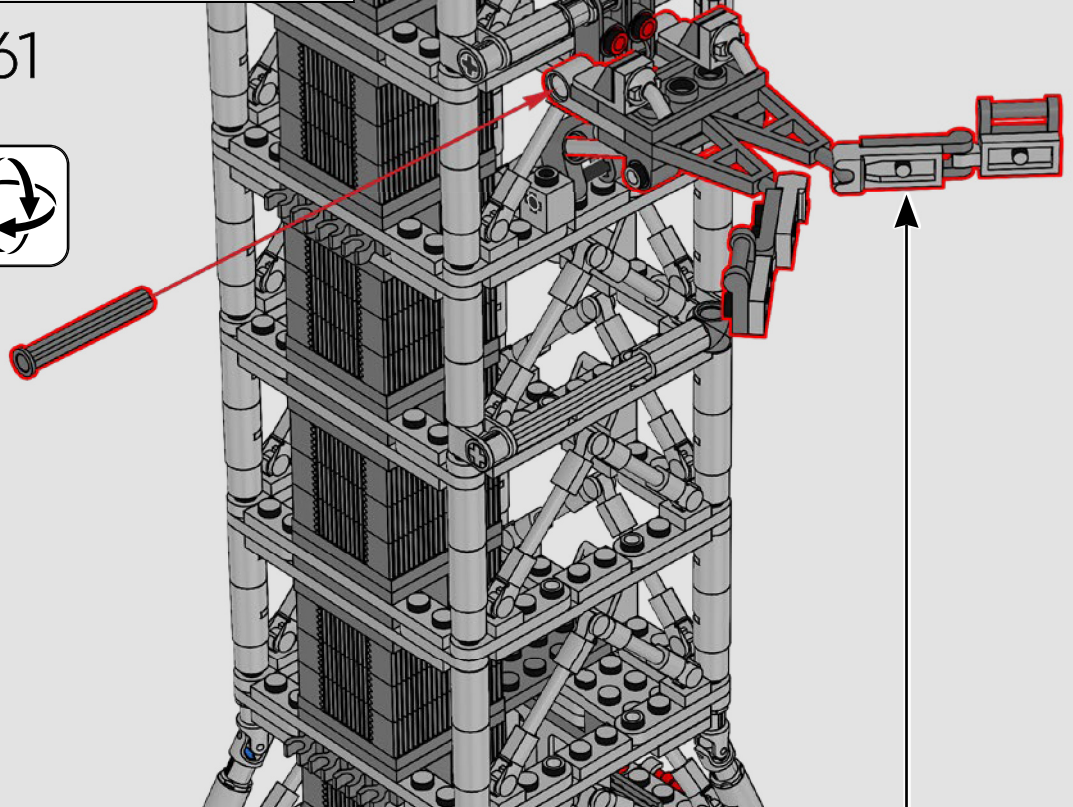

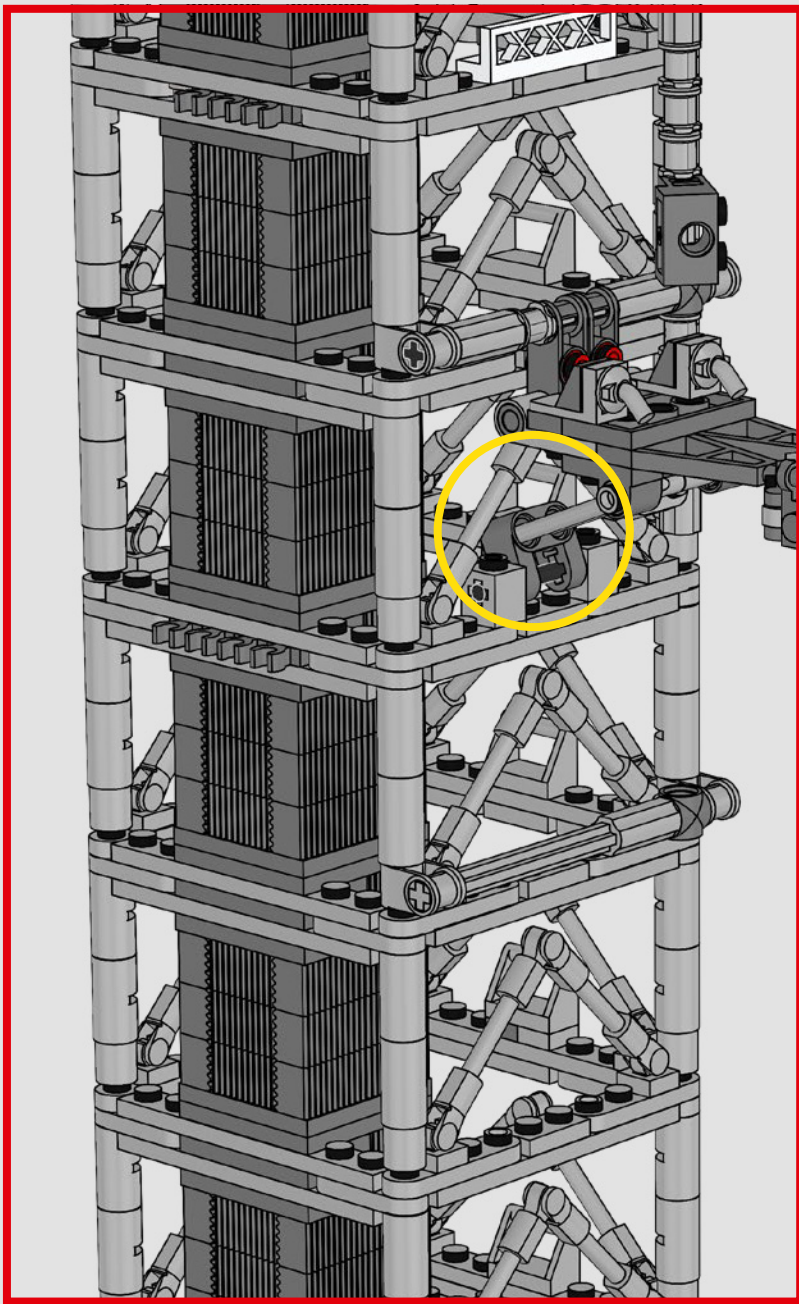

362

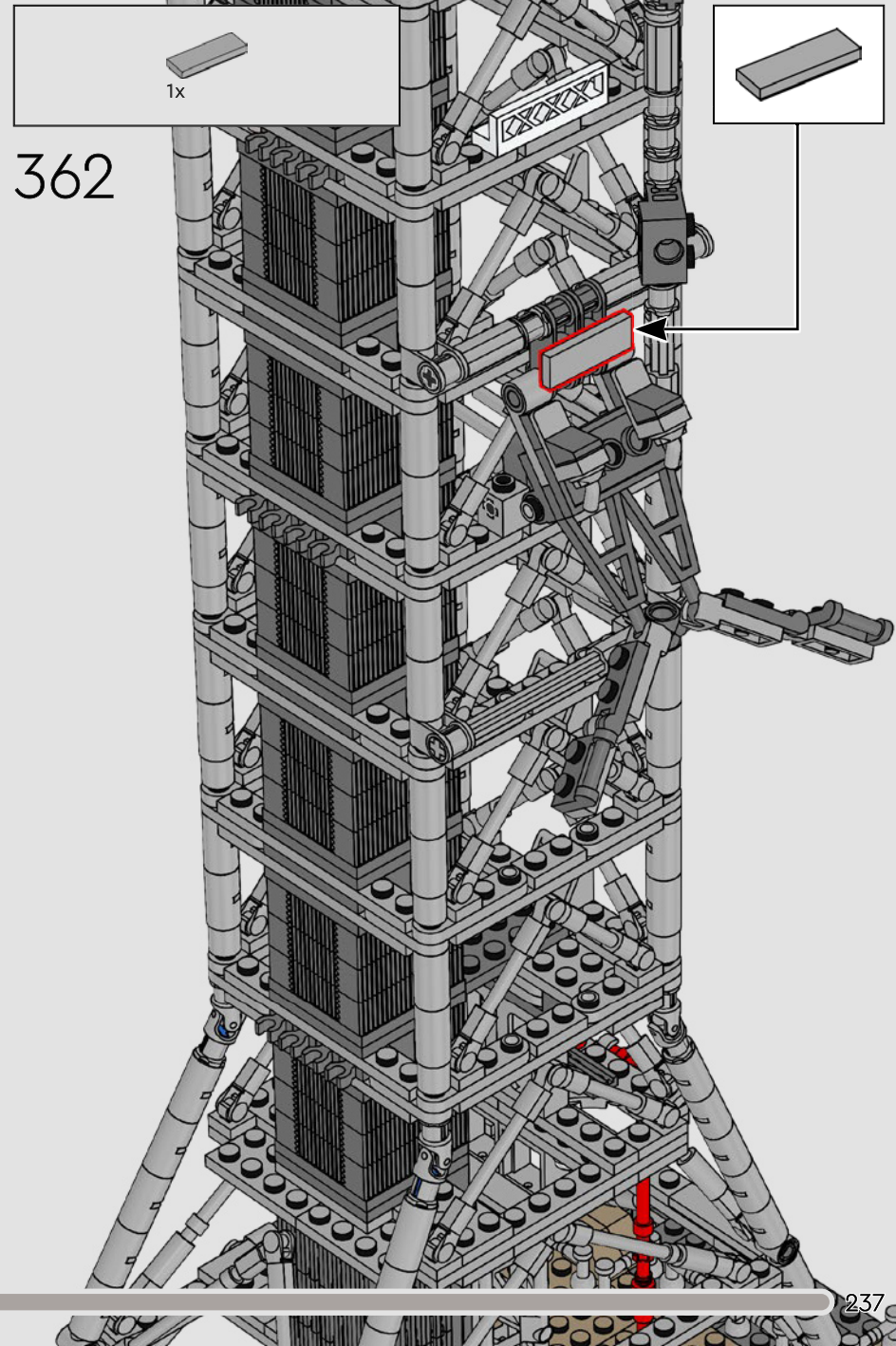

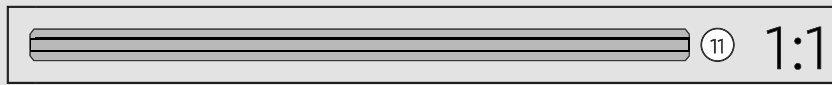
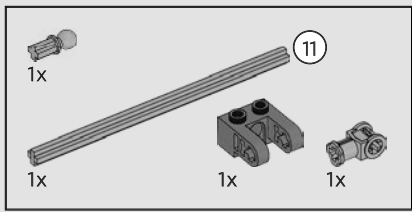

363

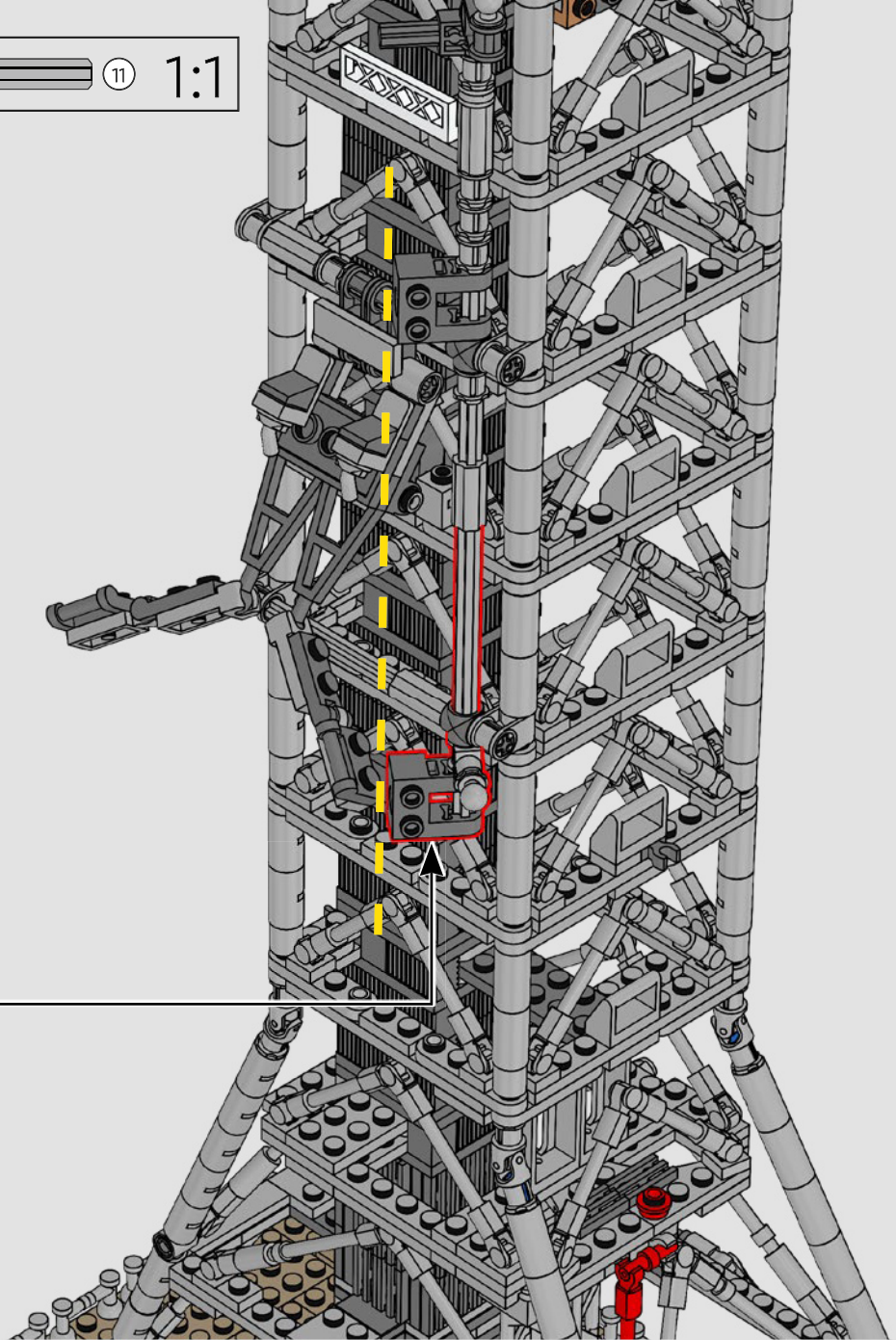
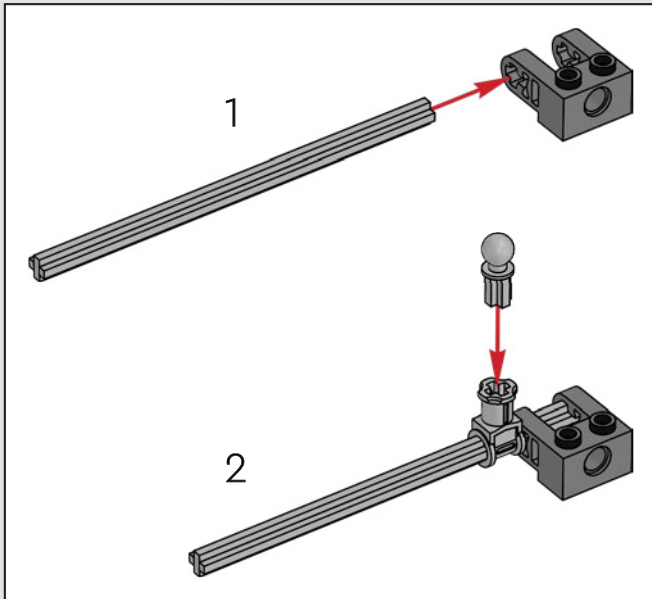

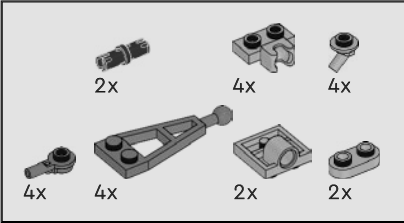
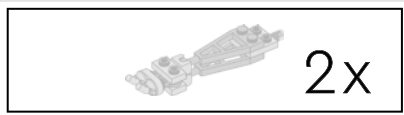

364

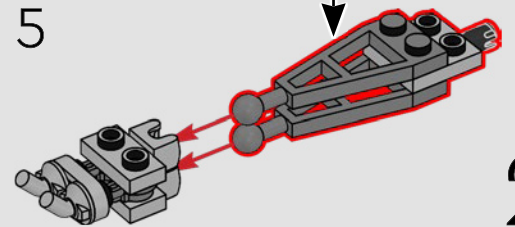
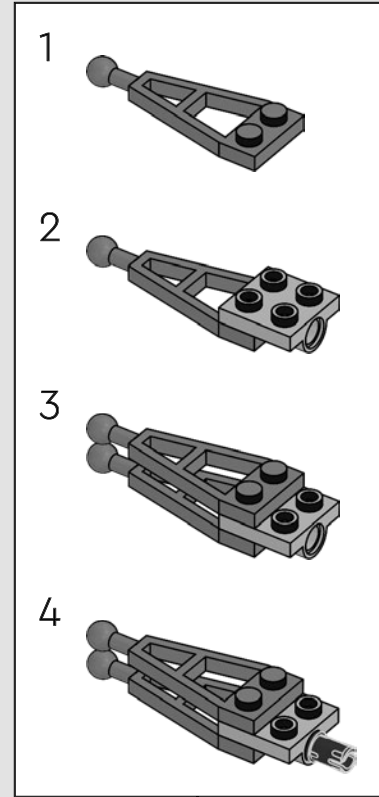
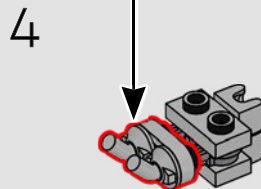
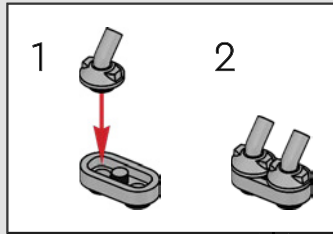
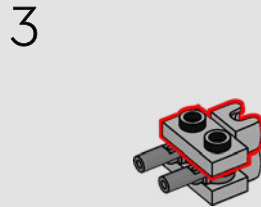
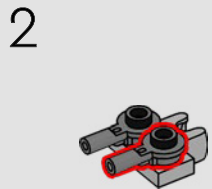
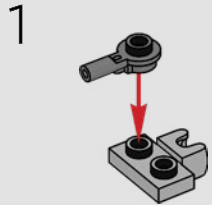

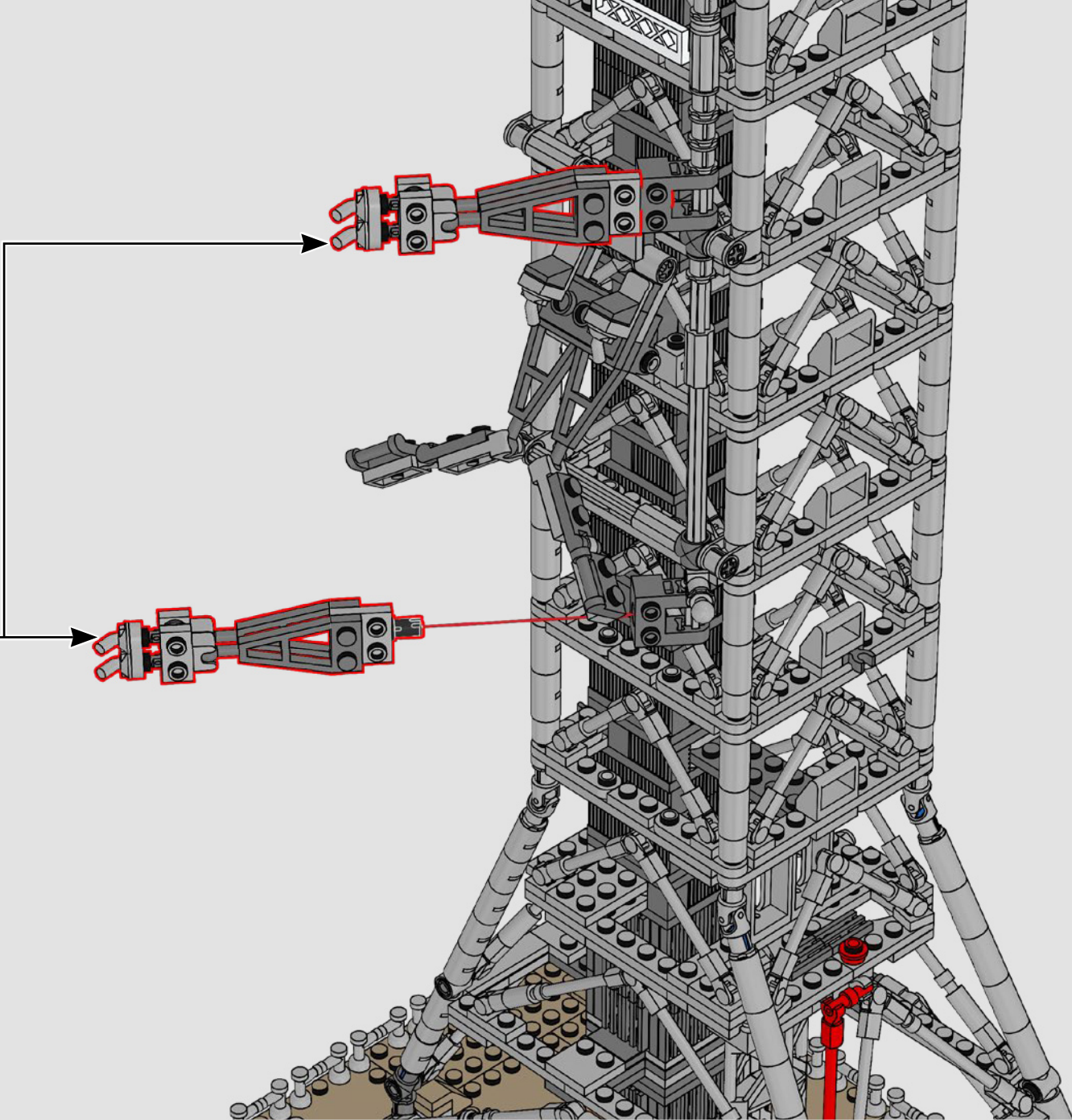

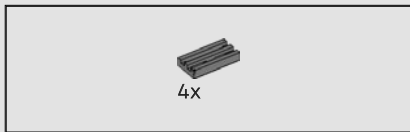

365

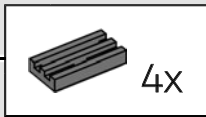
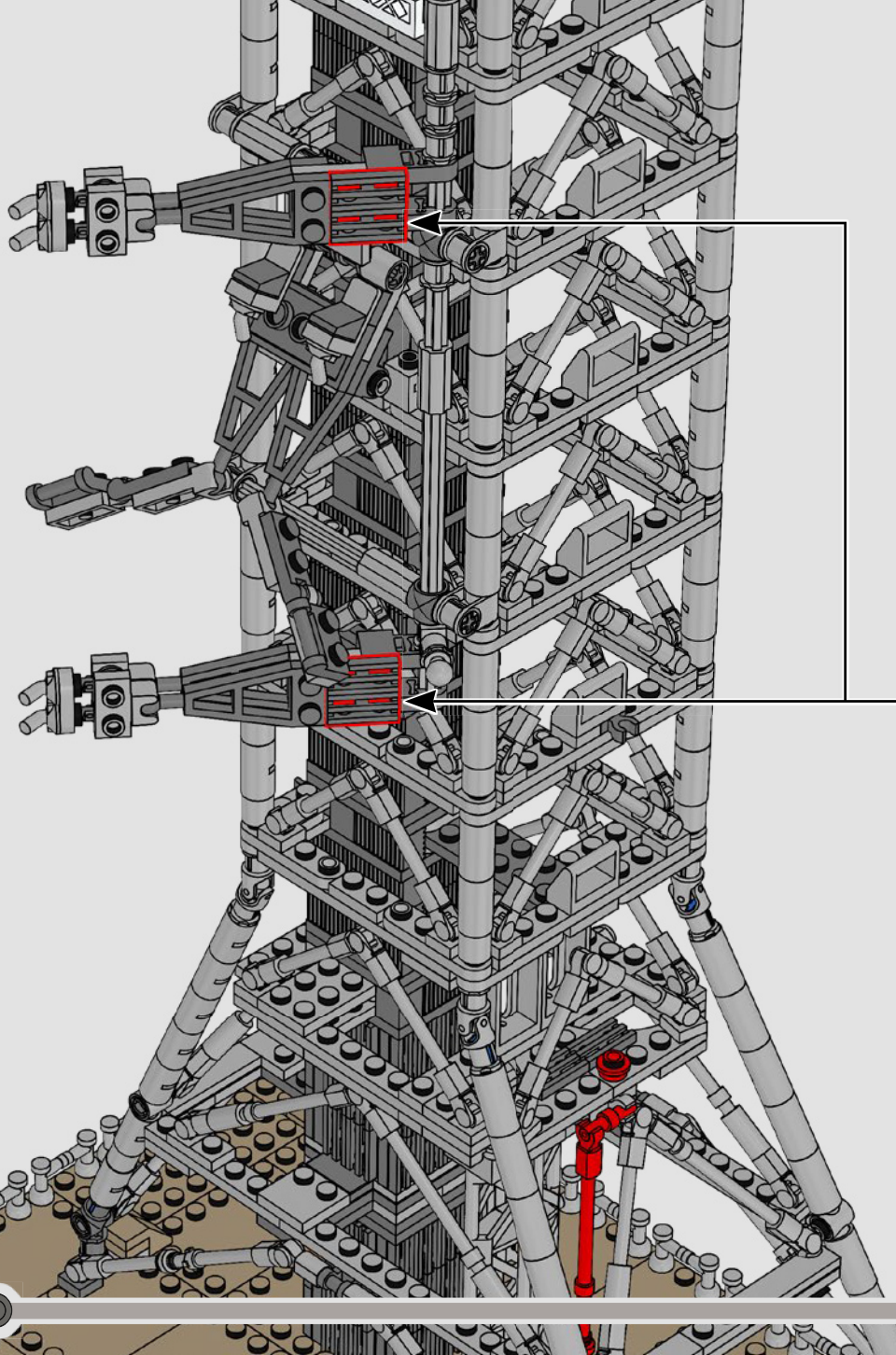

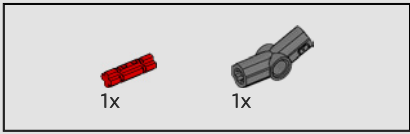
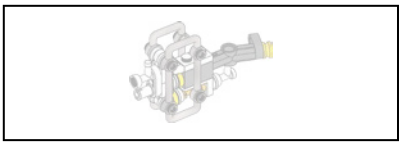

366

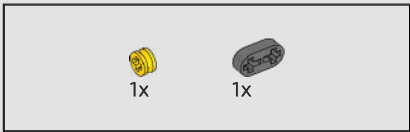
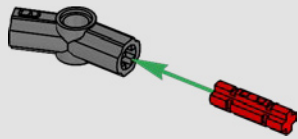

367

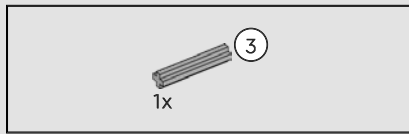
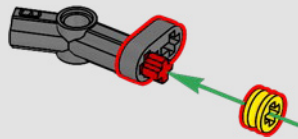

368

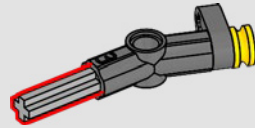

369

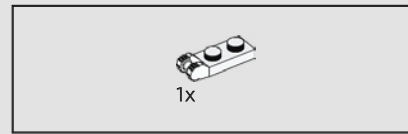
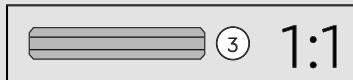
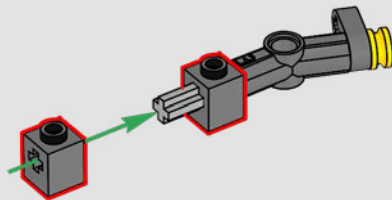

370

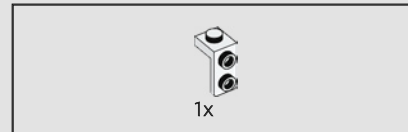
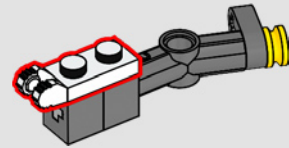

371

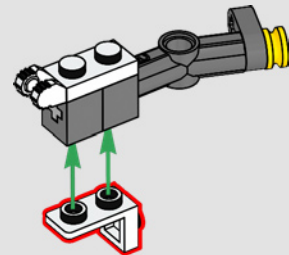



372

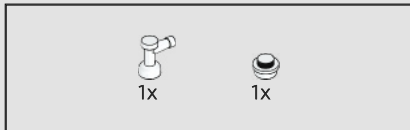
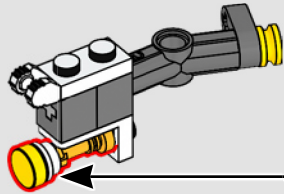
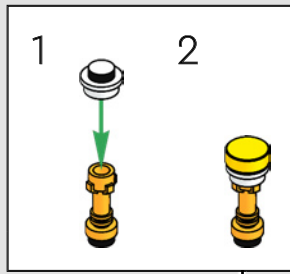

373

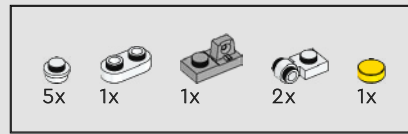
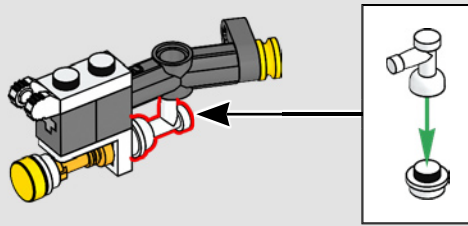

374

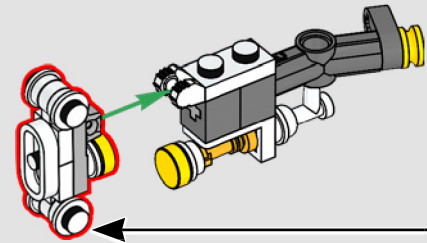
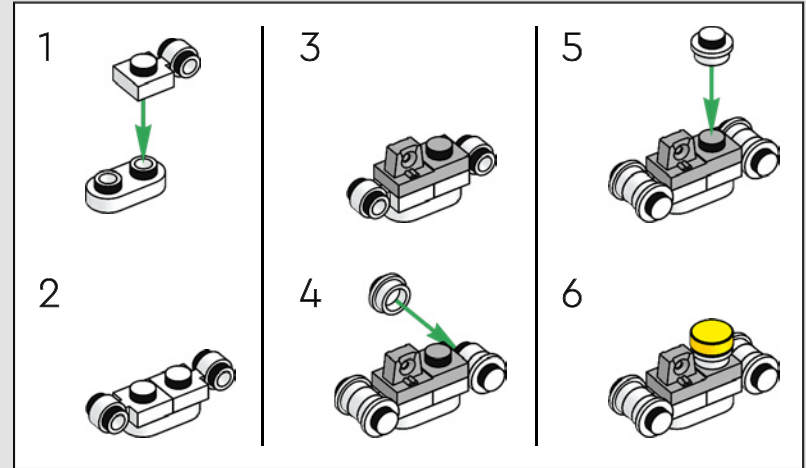

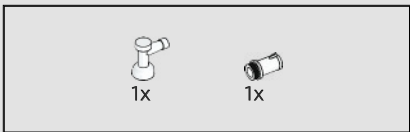

375

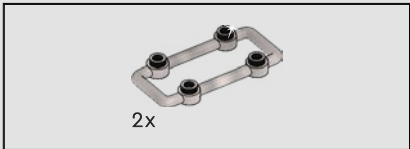
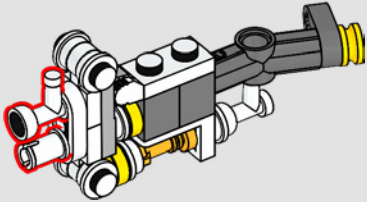

376

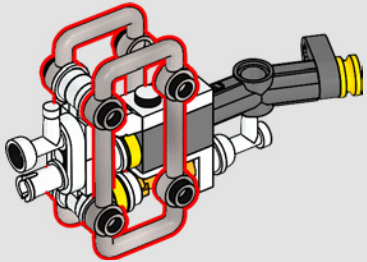

377

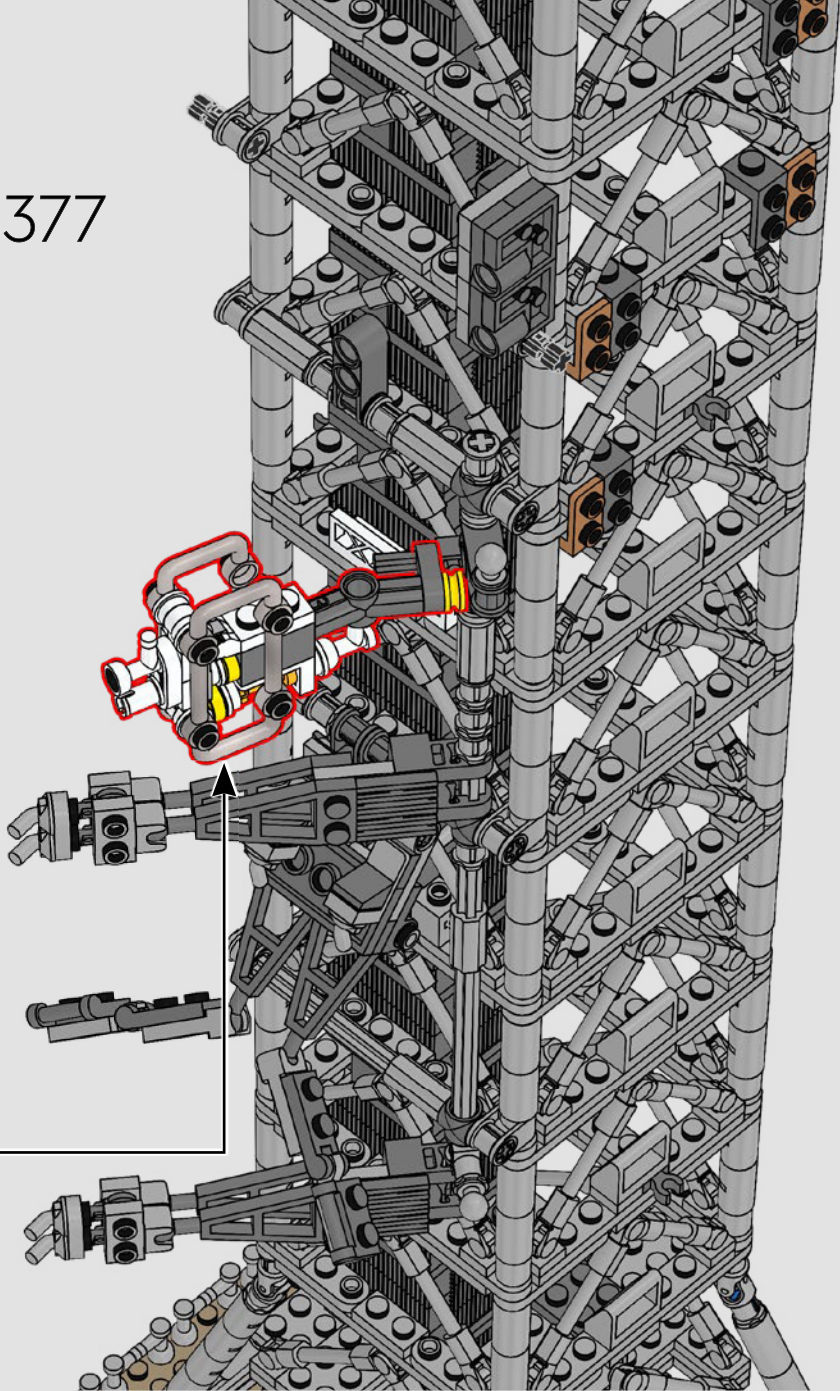

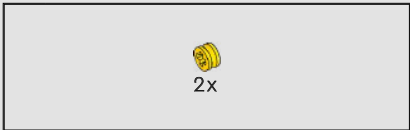

378

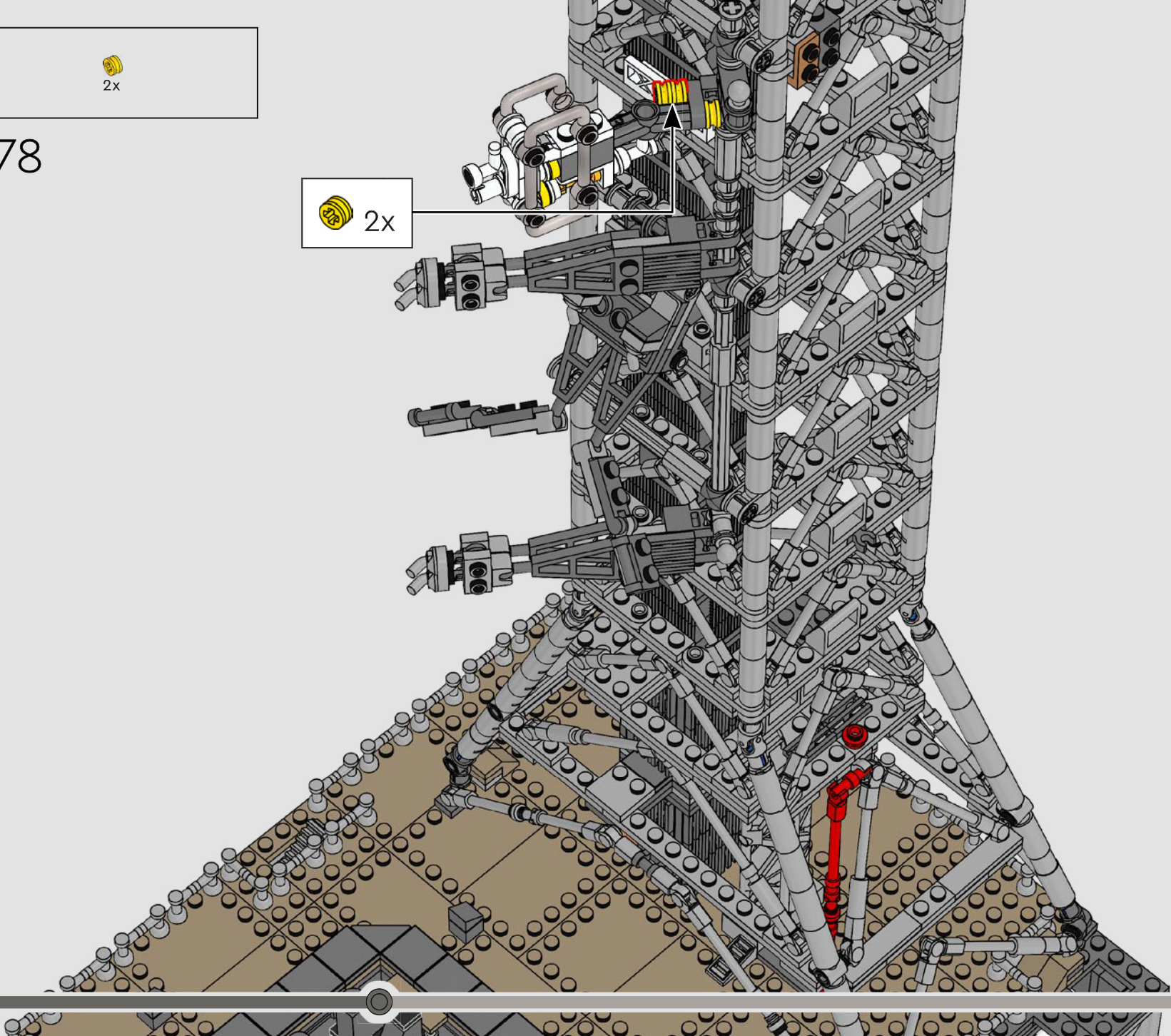

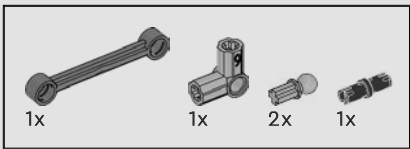

379

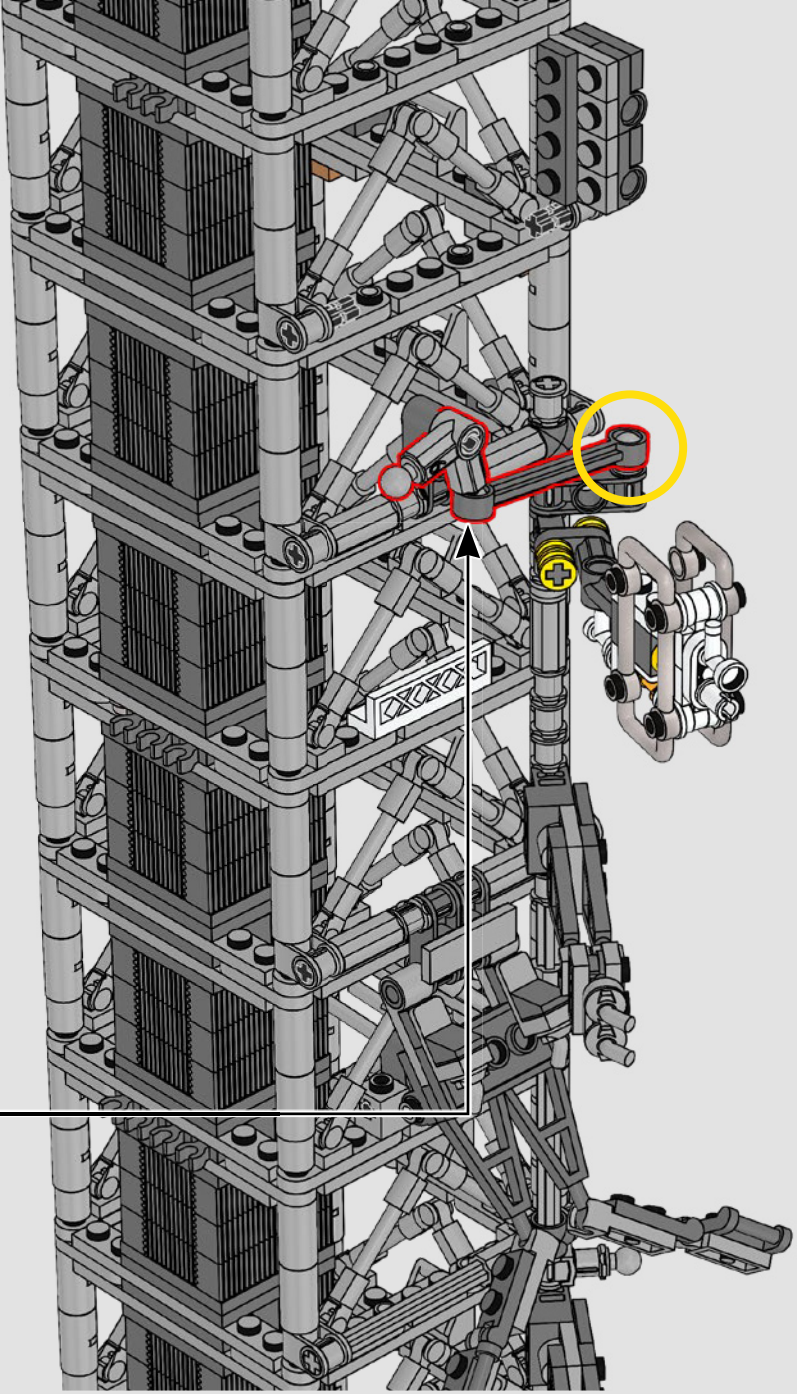
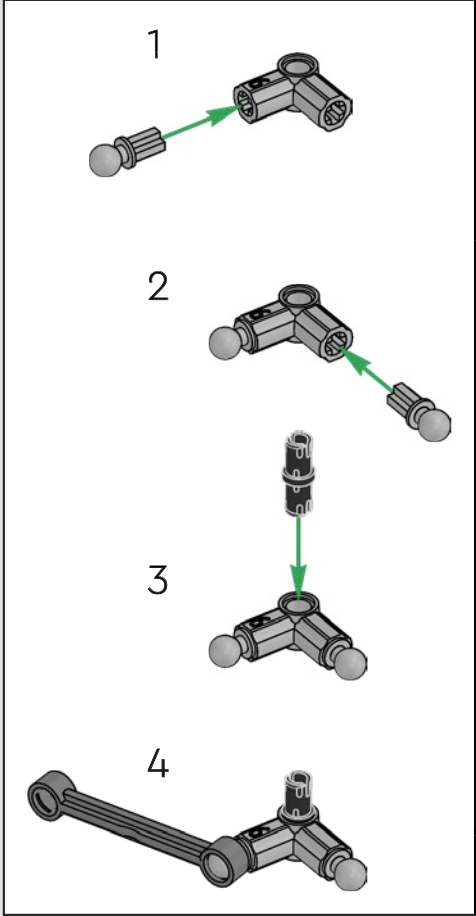

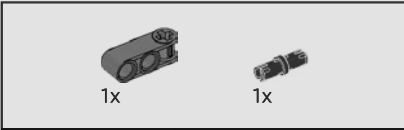
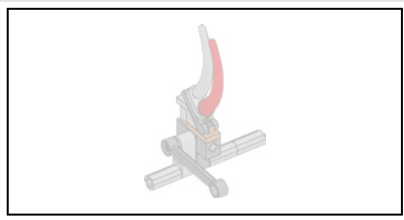

380

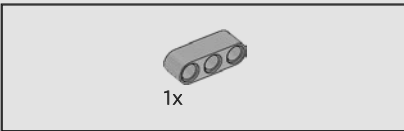
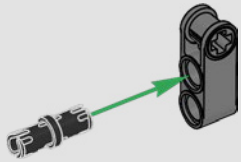

381

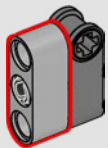

382

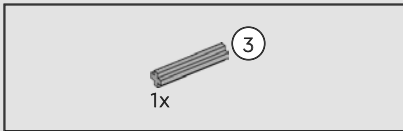
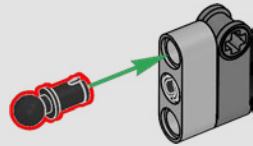

383

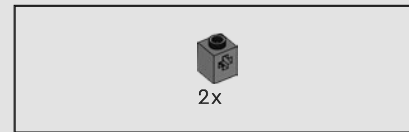
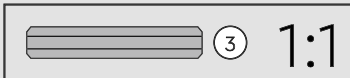
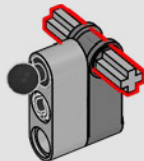

384

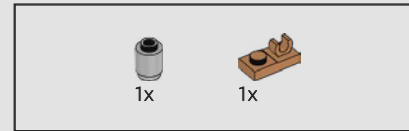
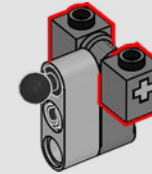

385

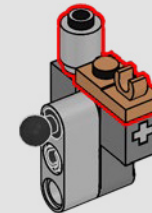

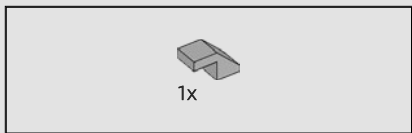

386

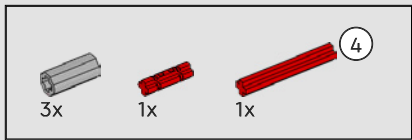
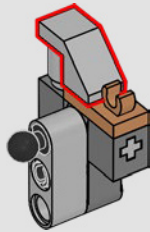

387

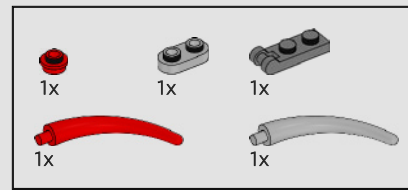
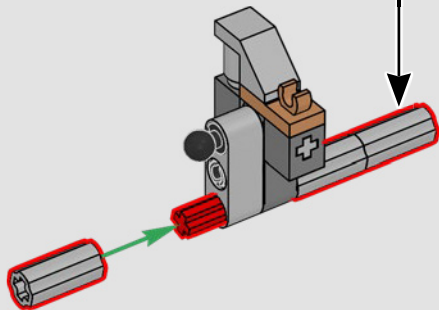
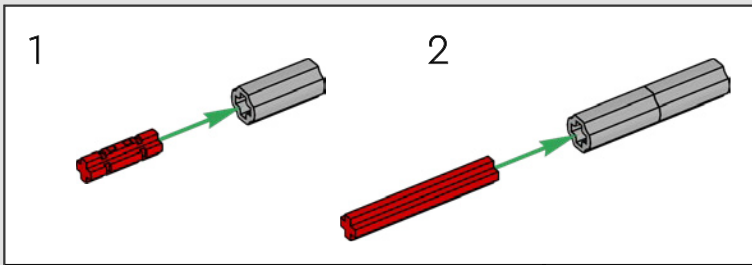

388

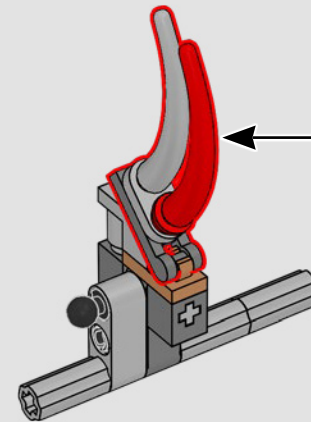
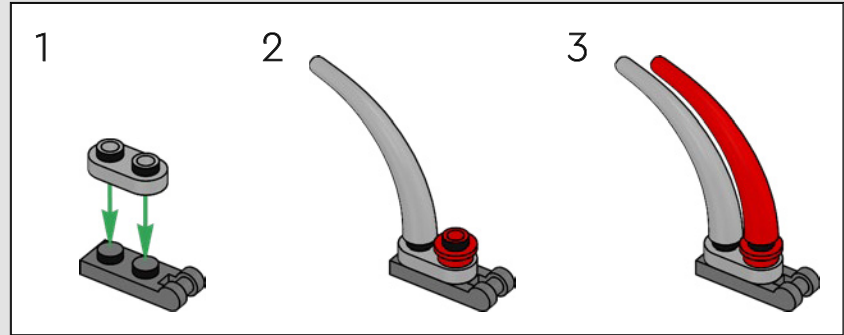

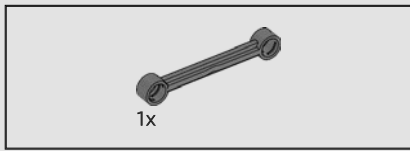

389

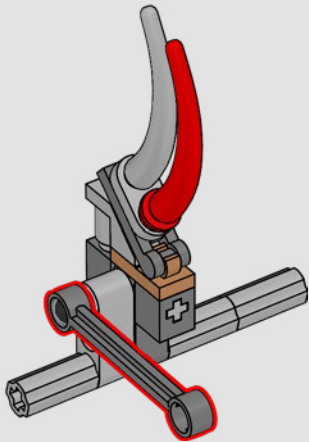

390

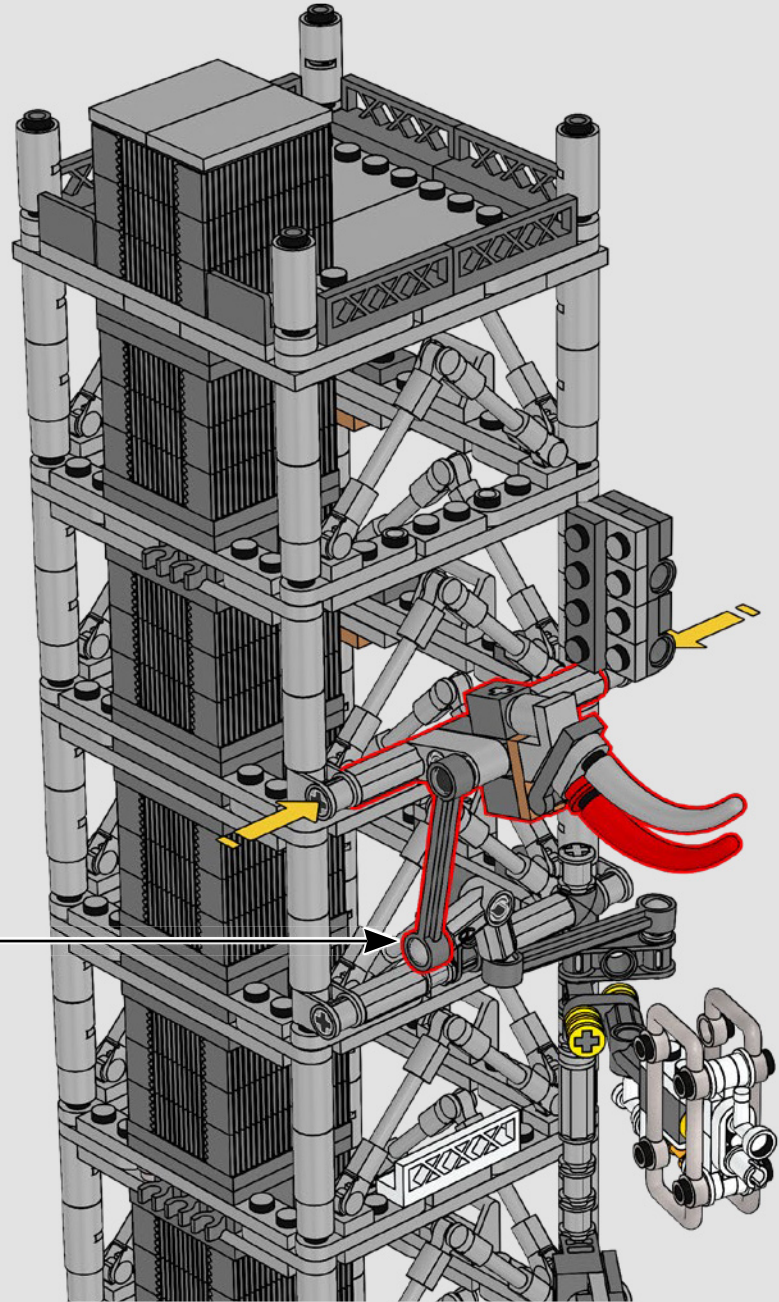

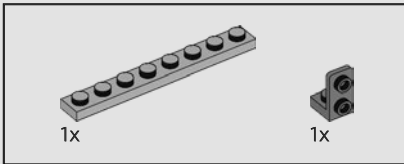
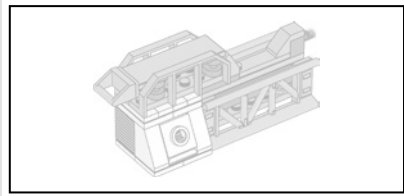

391

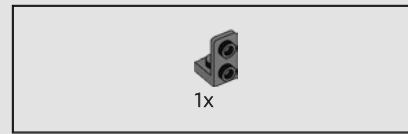
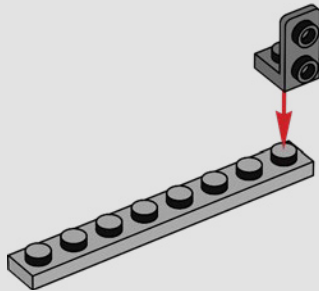

392

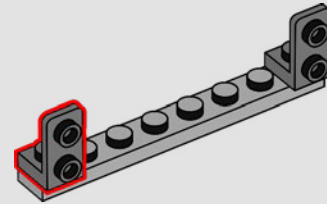

393

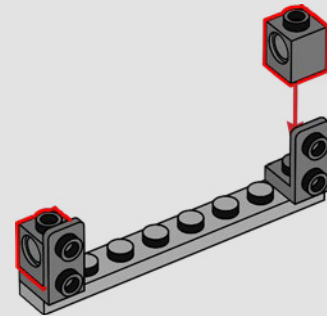

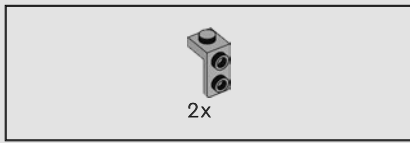

394

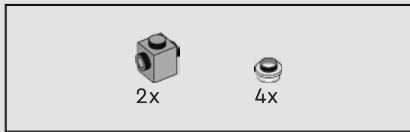
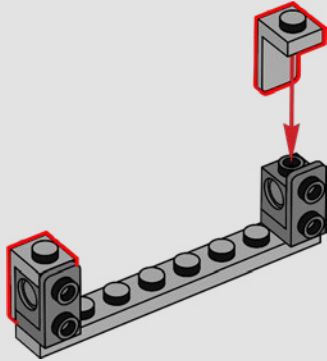

395

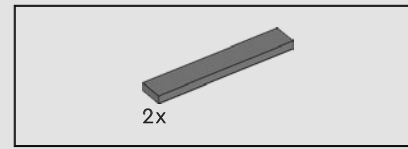
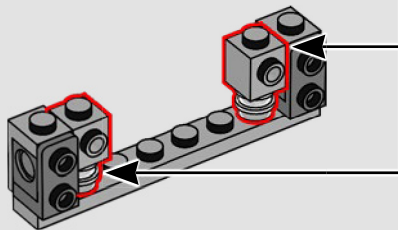
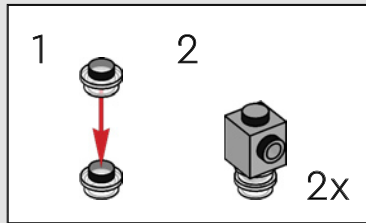

396

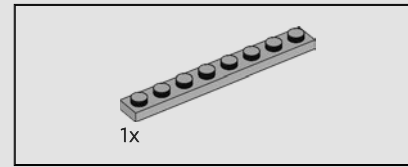
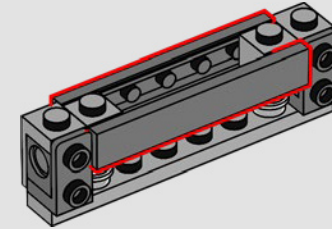

397

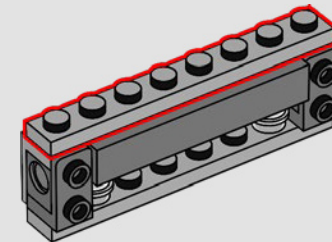

2x

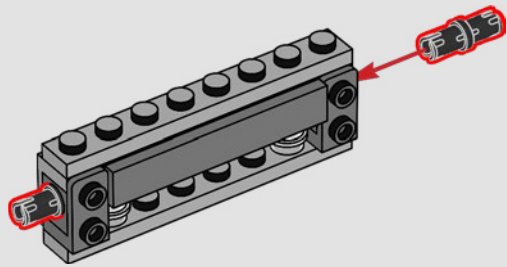

398

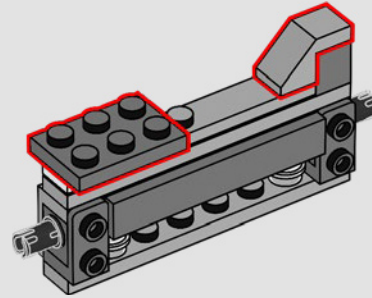

400

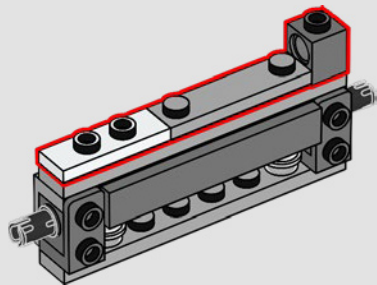

399

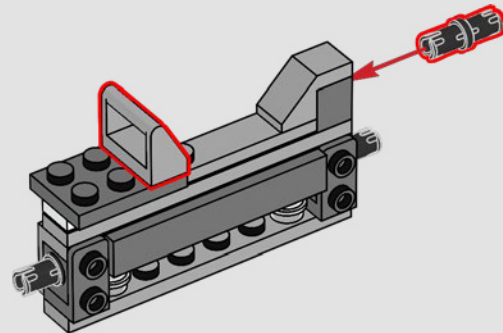

401

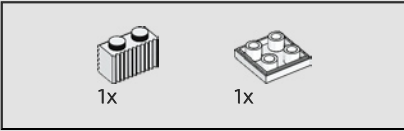
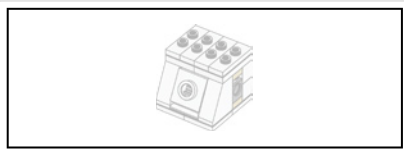

402

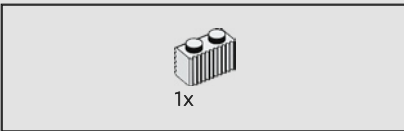
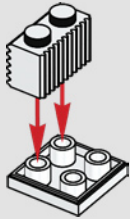

403

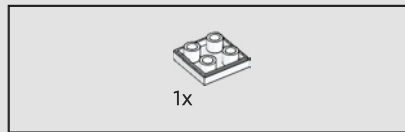
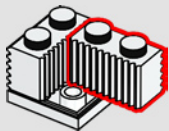

404

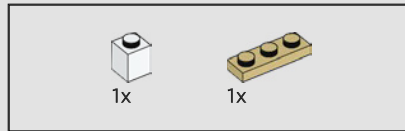
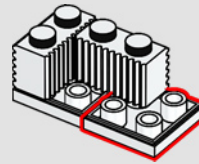

405

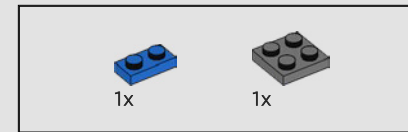
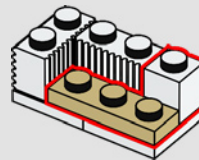

406

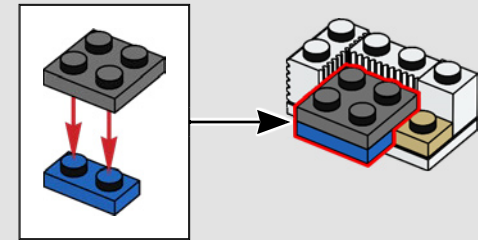

407

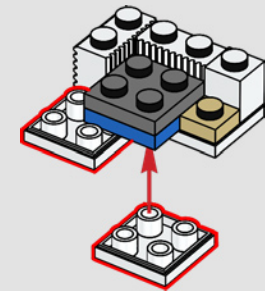

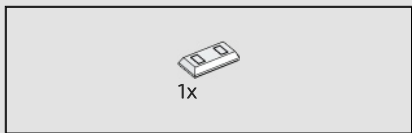

408

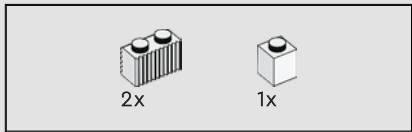
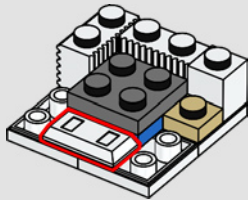

409

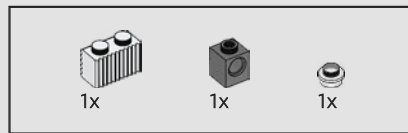
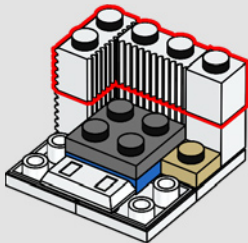

410

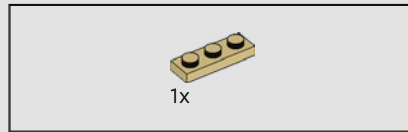
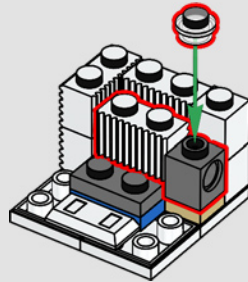

411

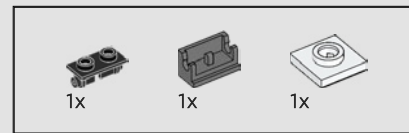
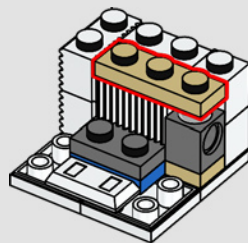

412

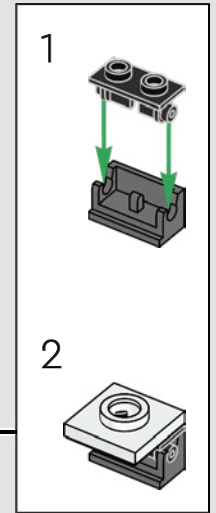
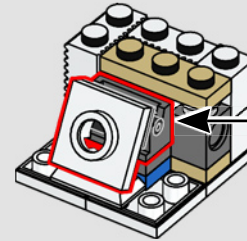

413

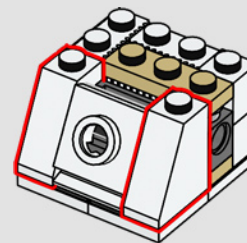

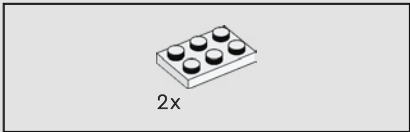

414

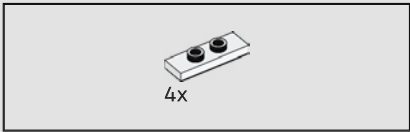
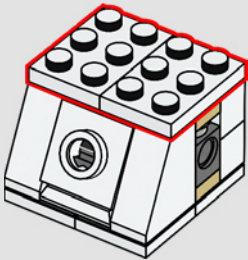

415



416

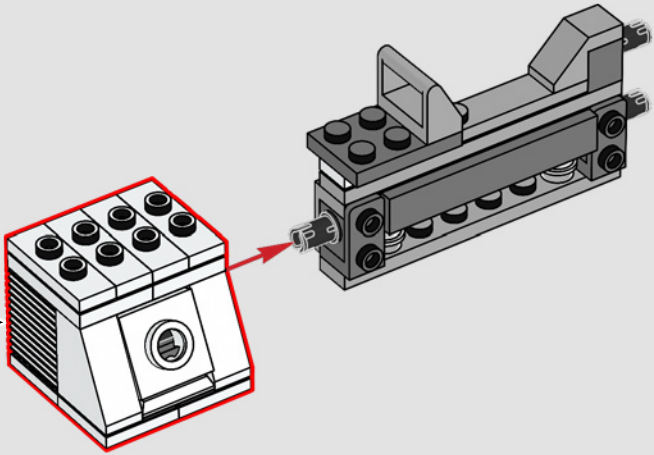

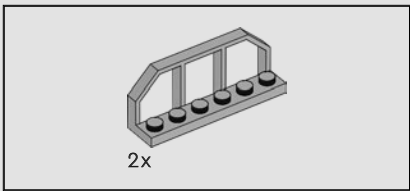

417

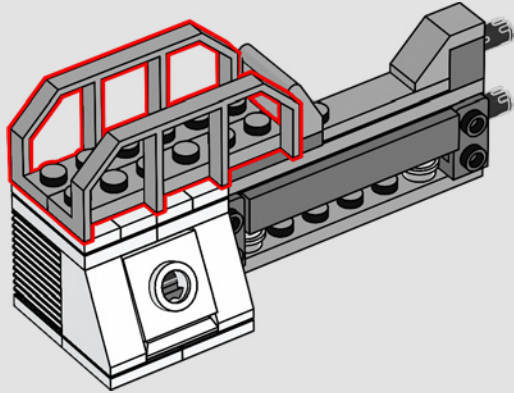

418

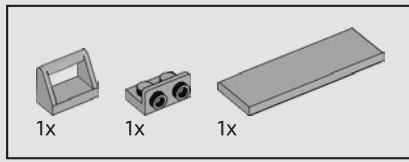
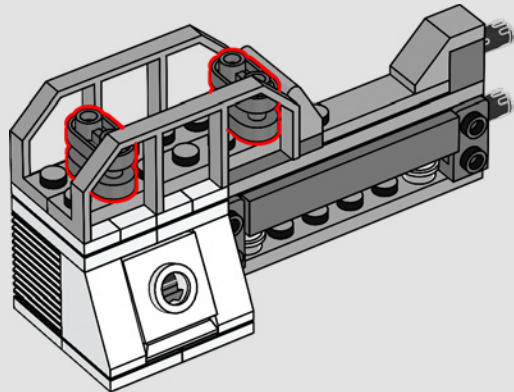

419

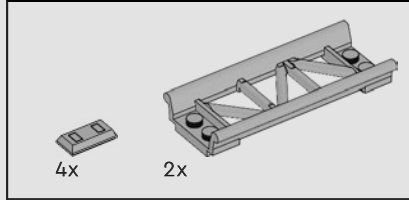
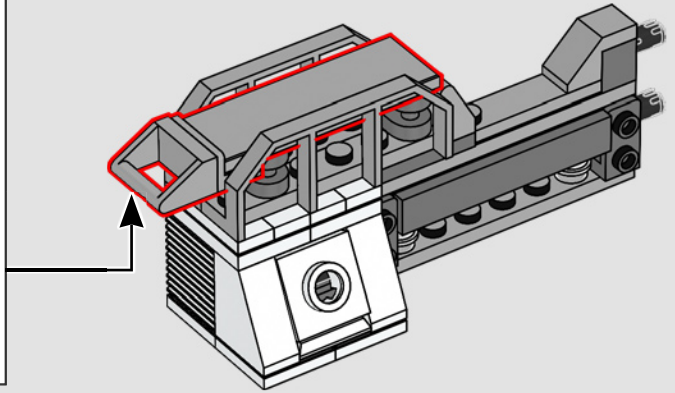
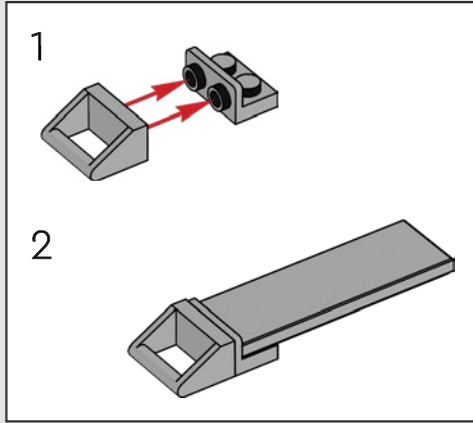

420

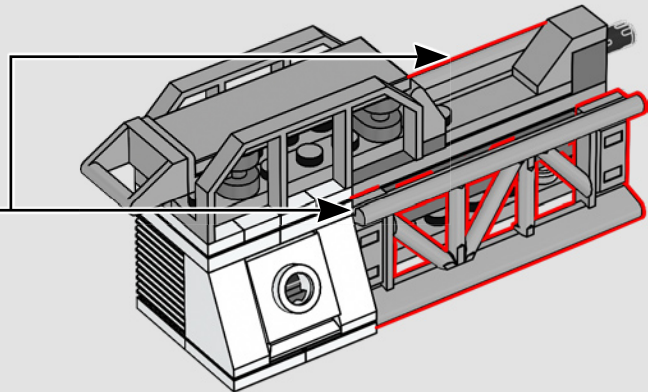
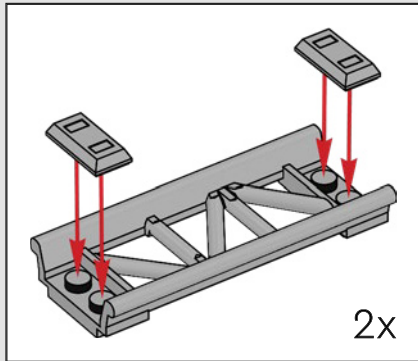

421

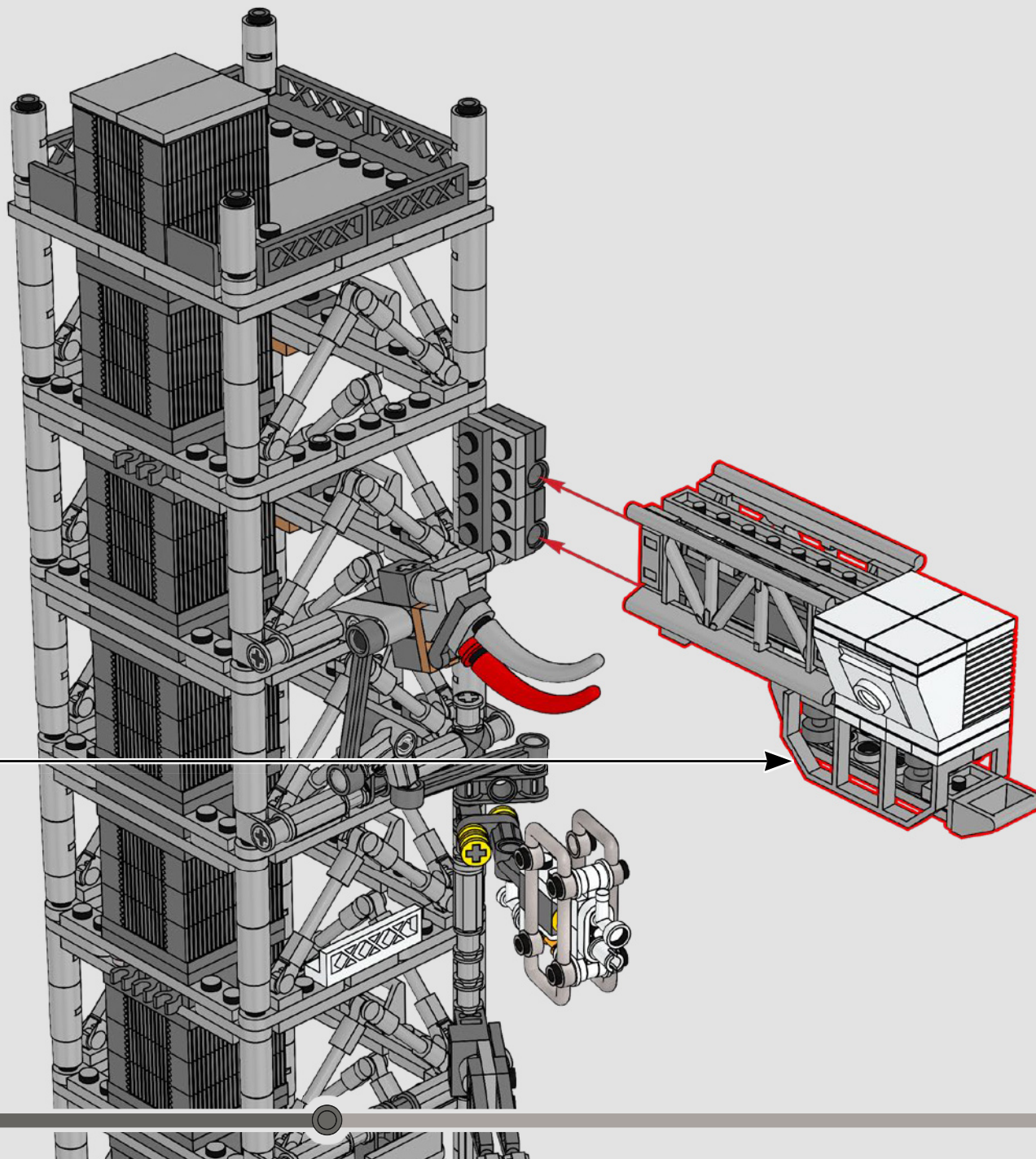

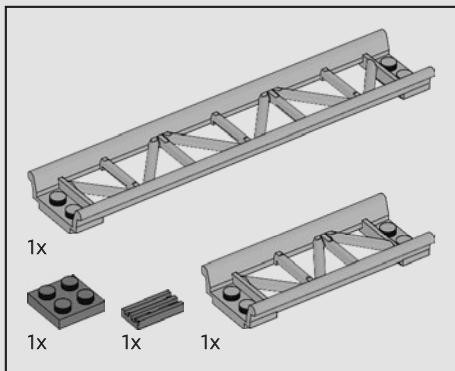

422

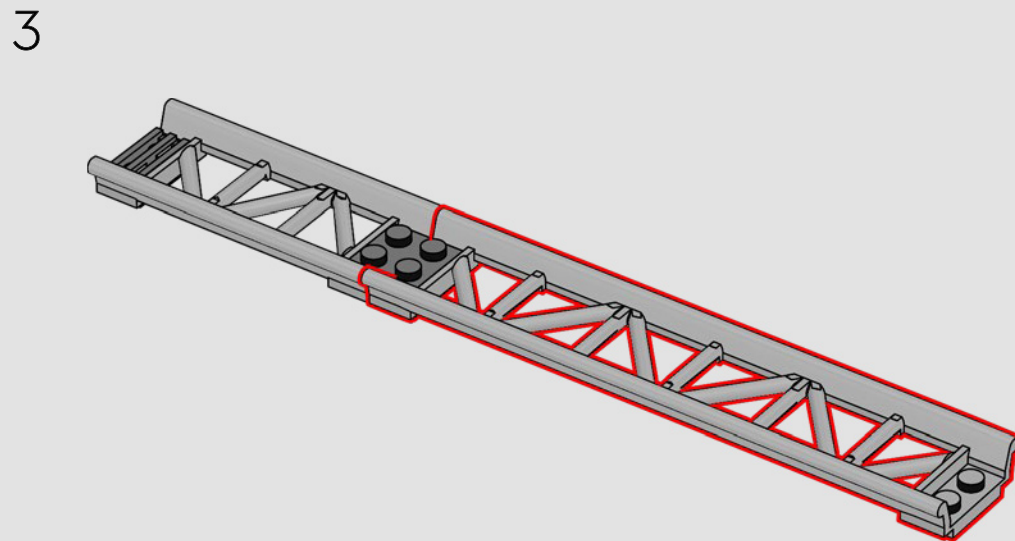
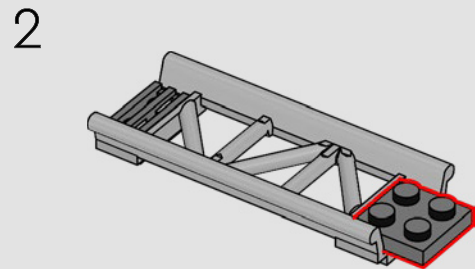
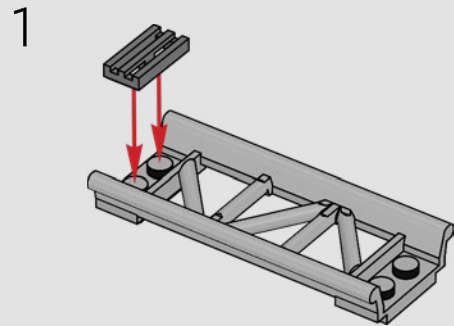

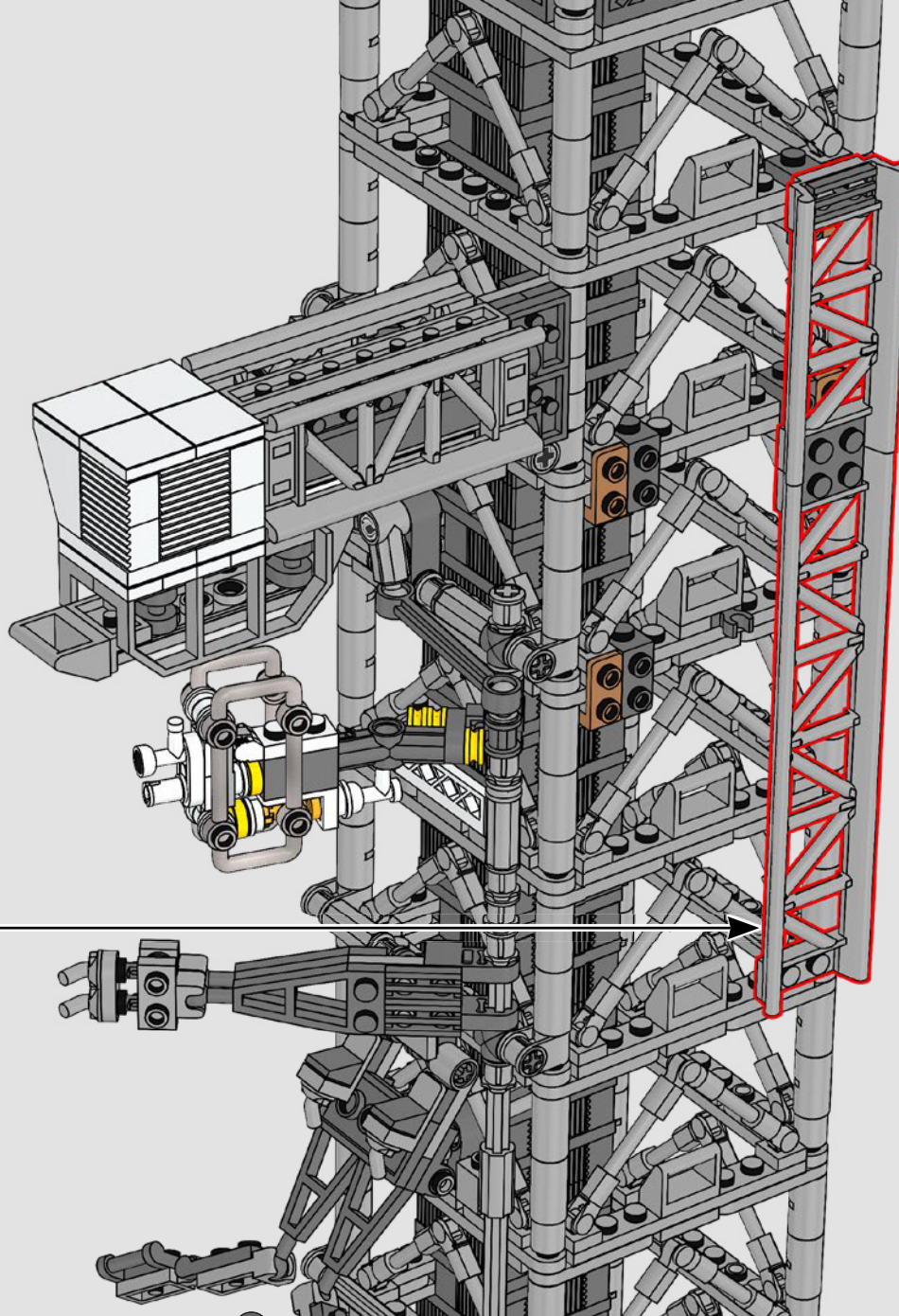

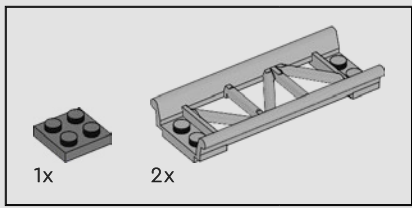

423

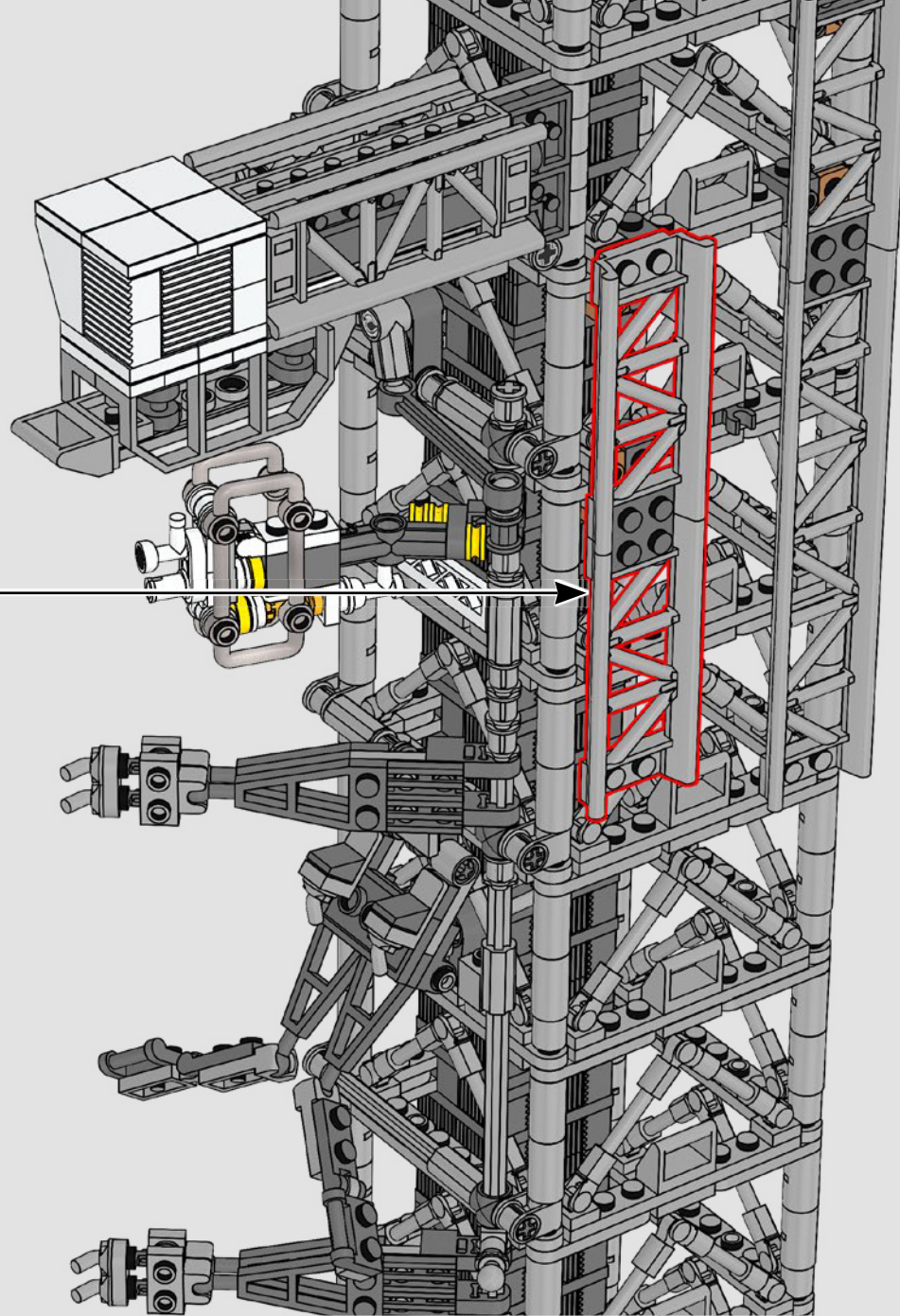
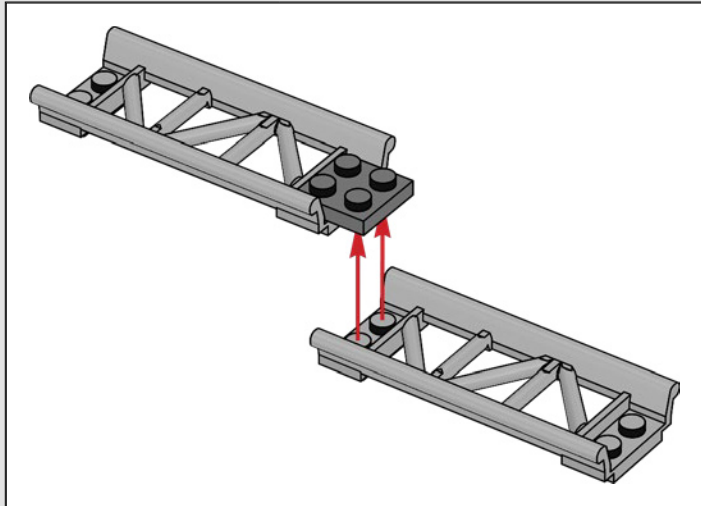



424

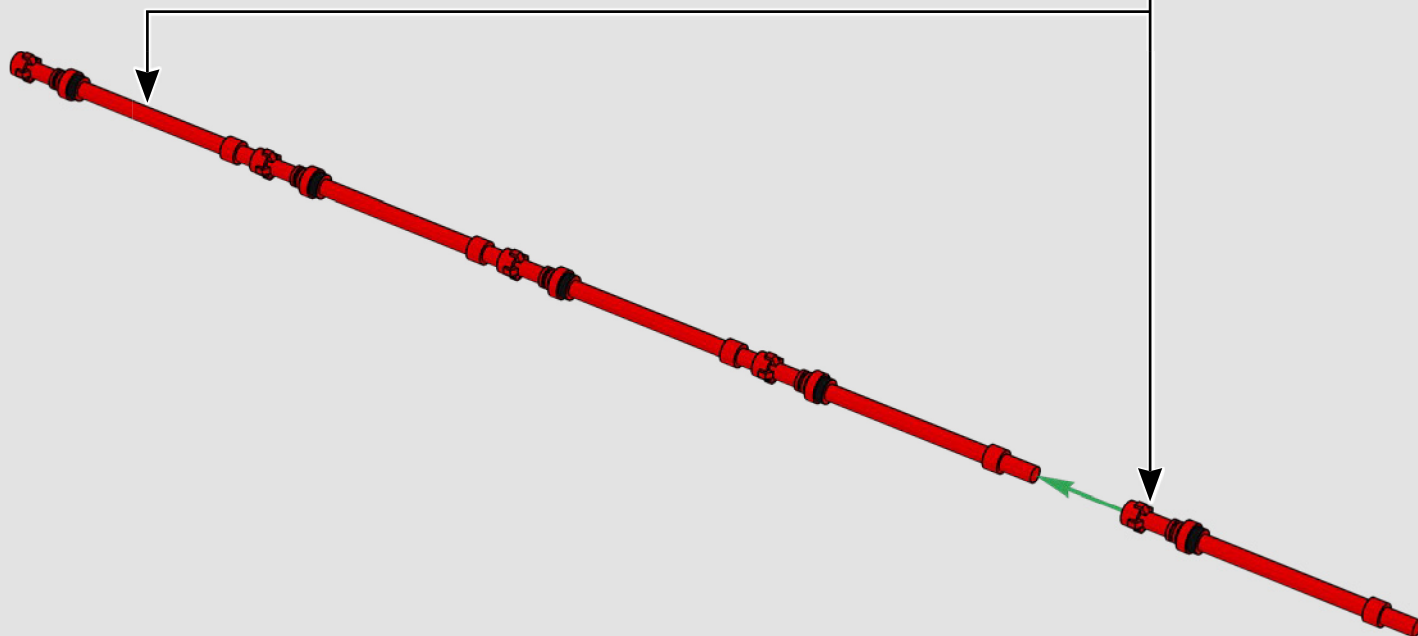
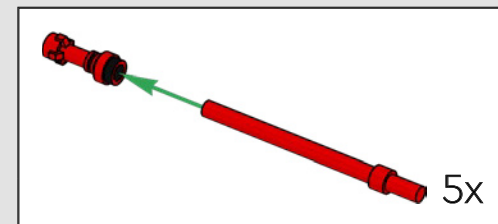

425

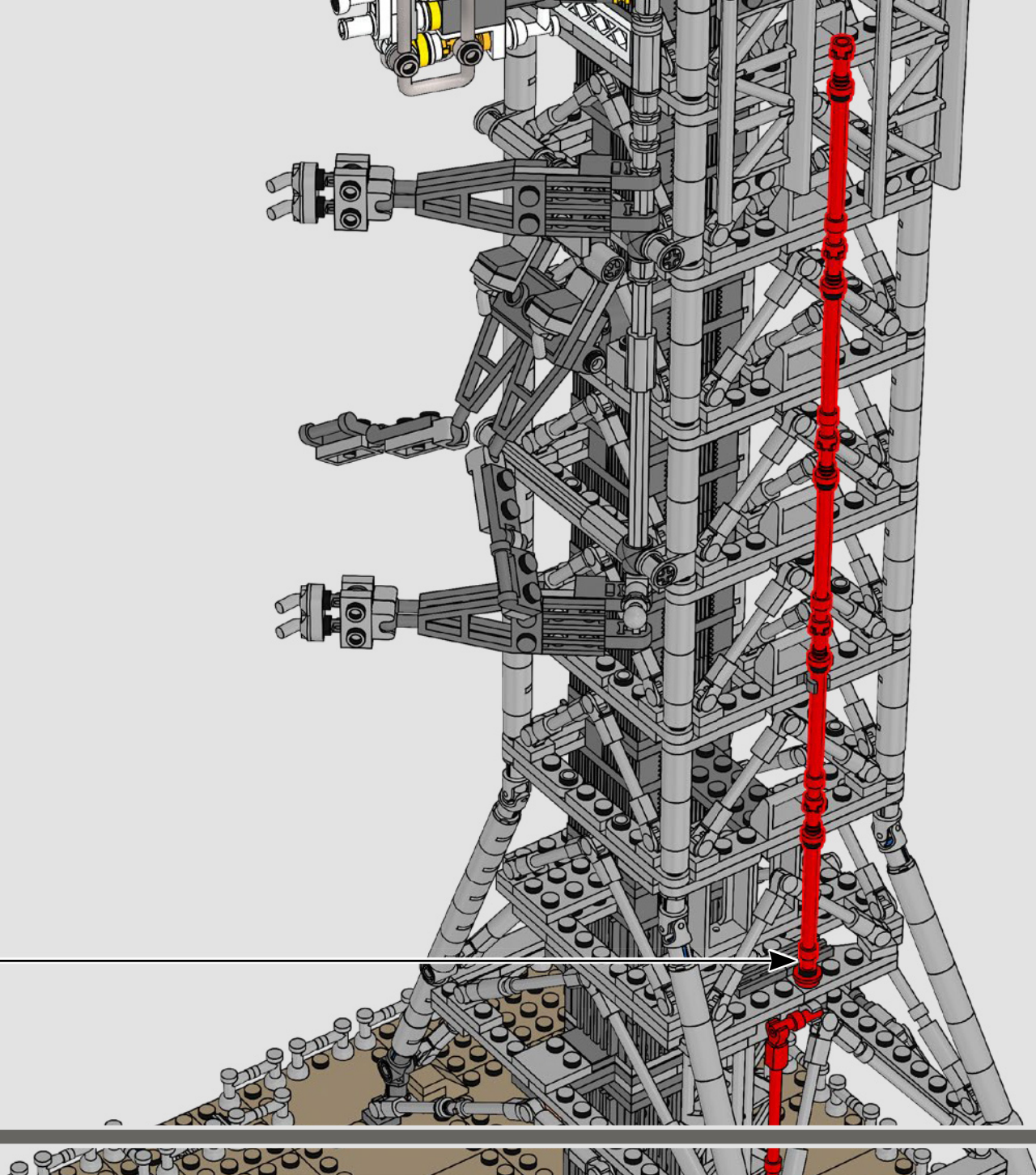

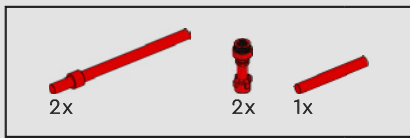

426

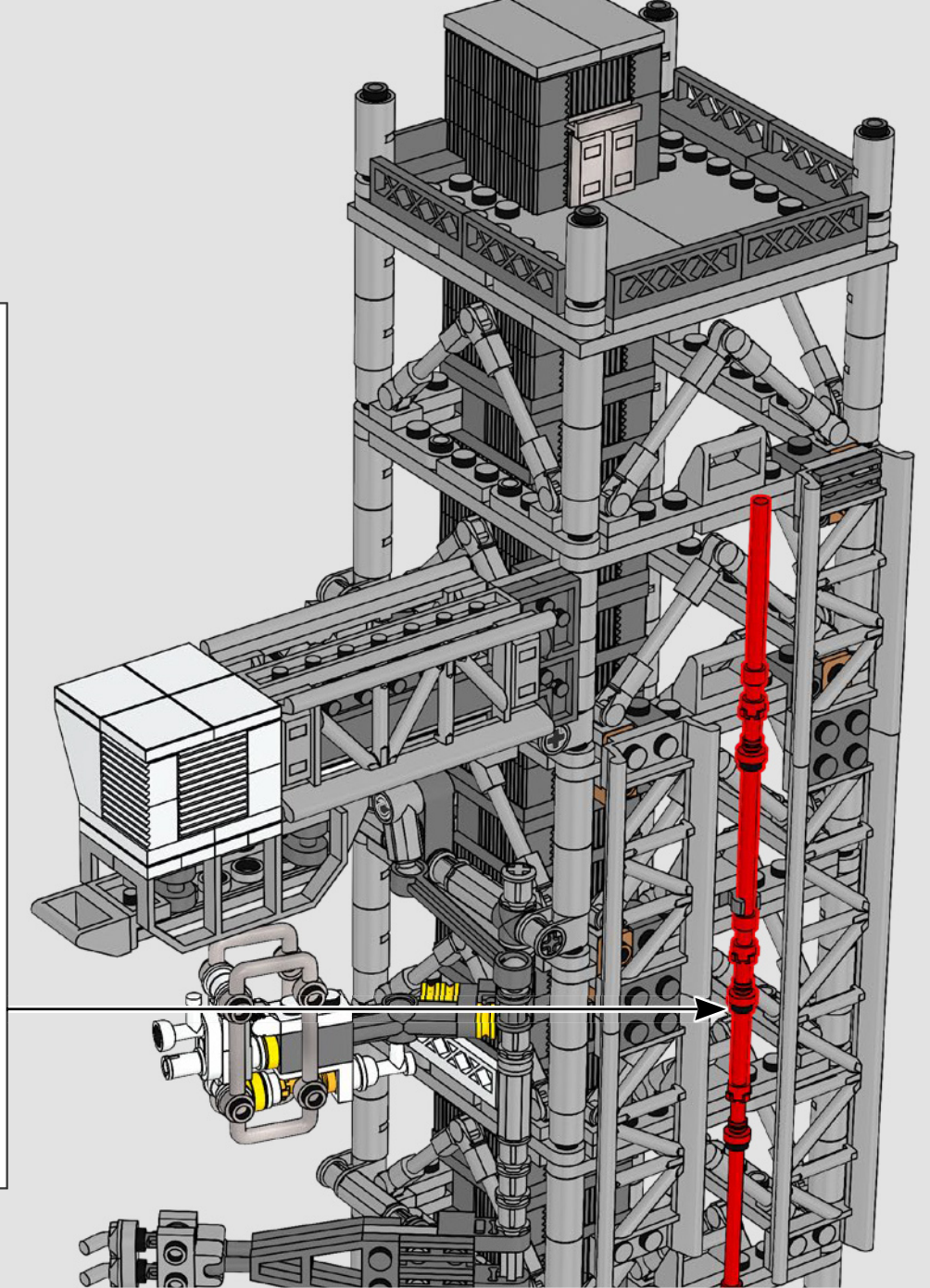
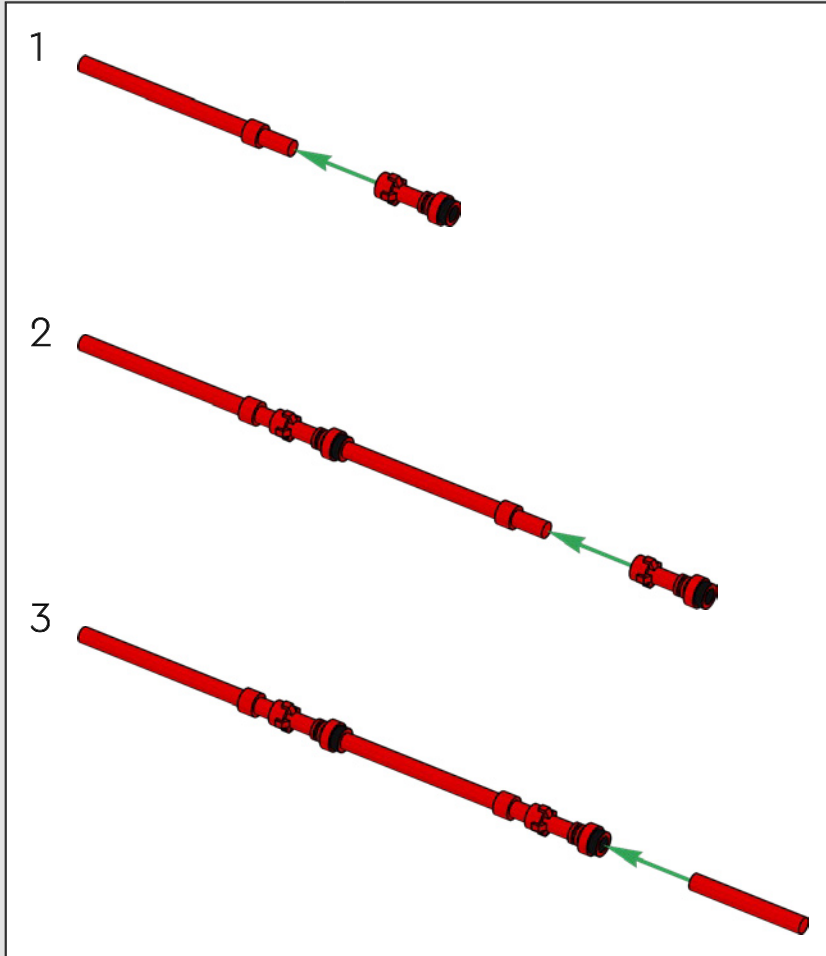

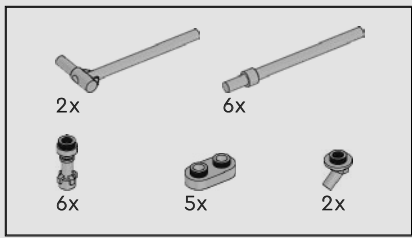

427

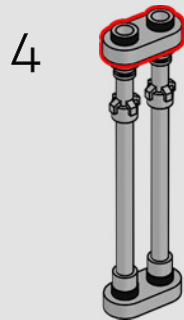
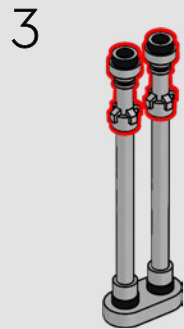
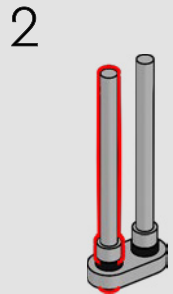
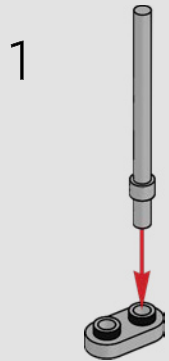

5

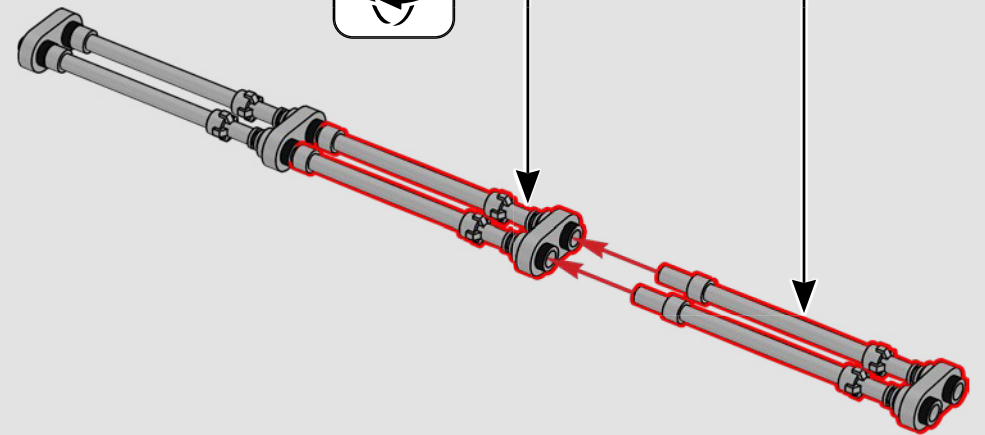
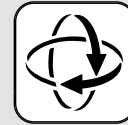
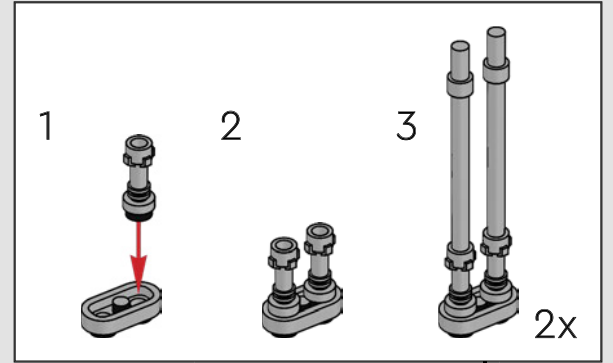

6

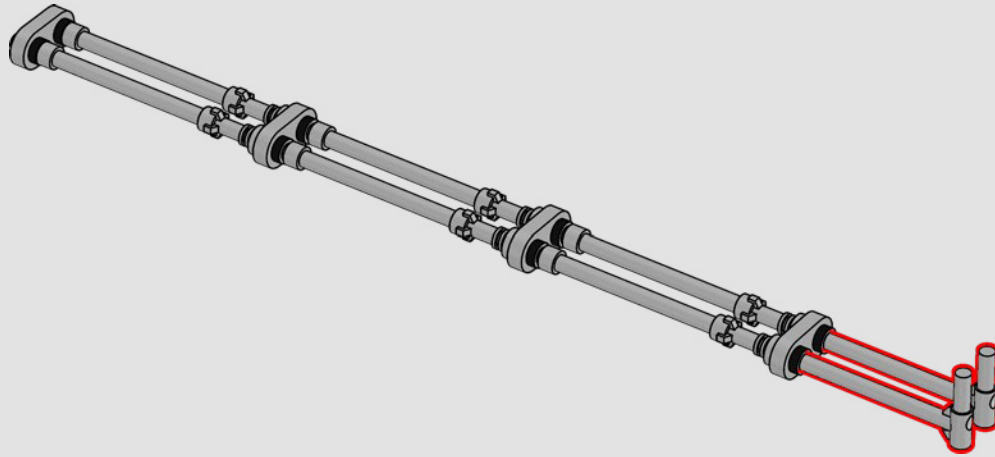

7

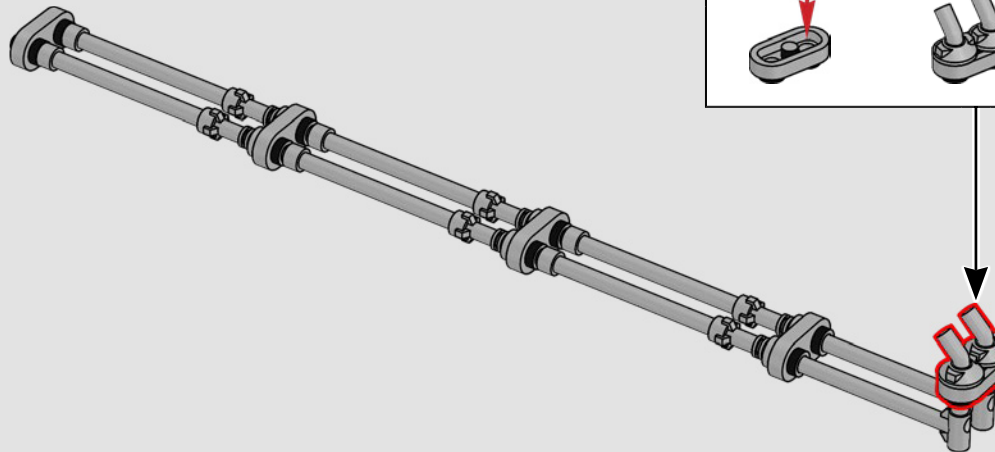

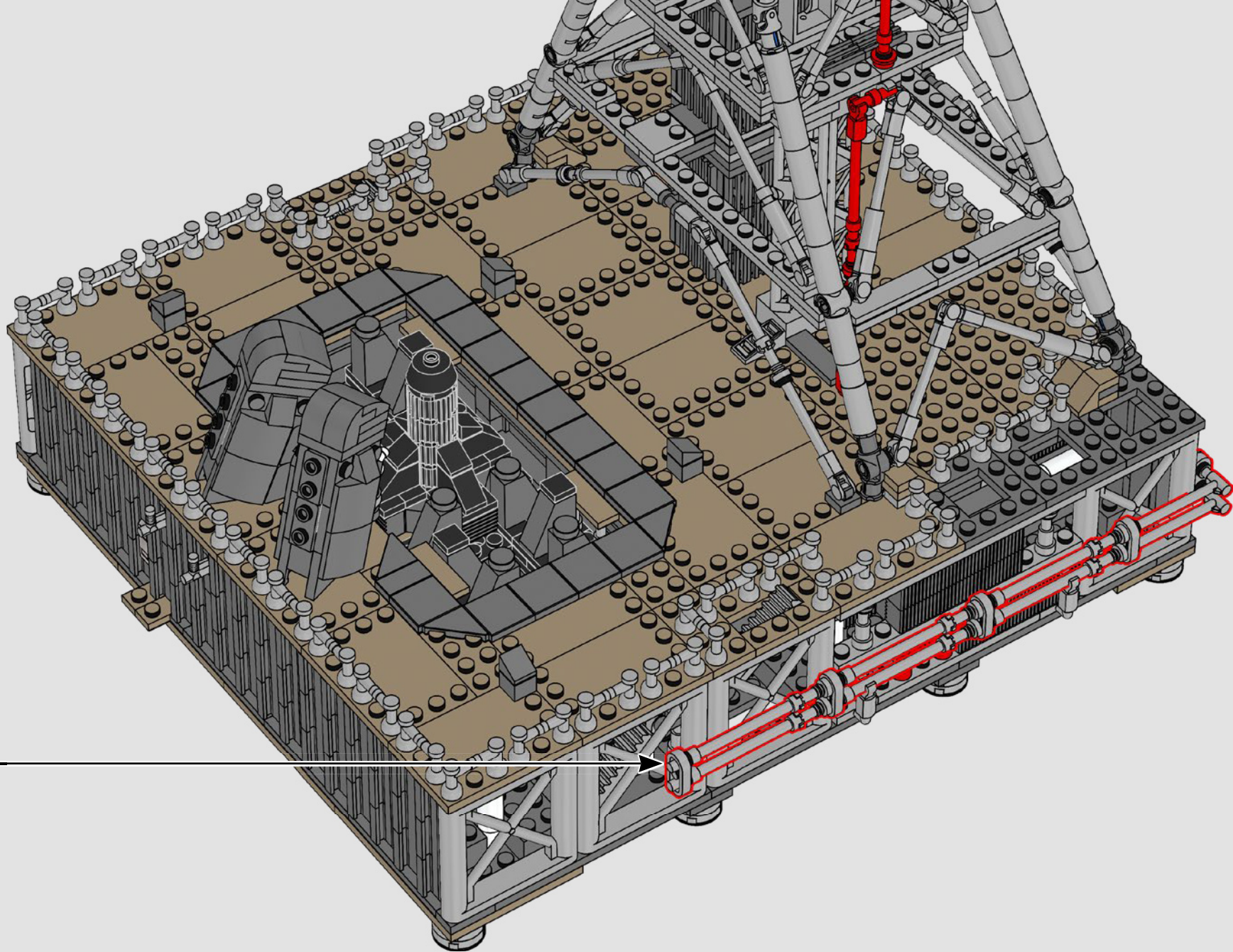

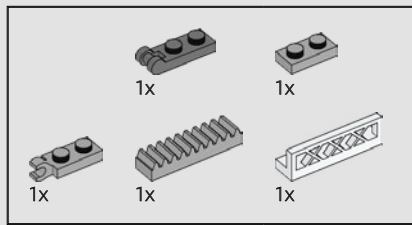

428

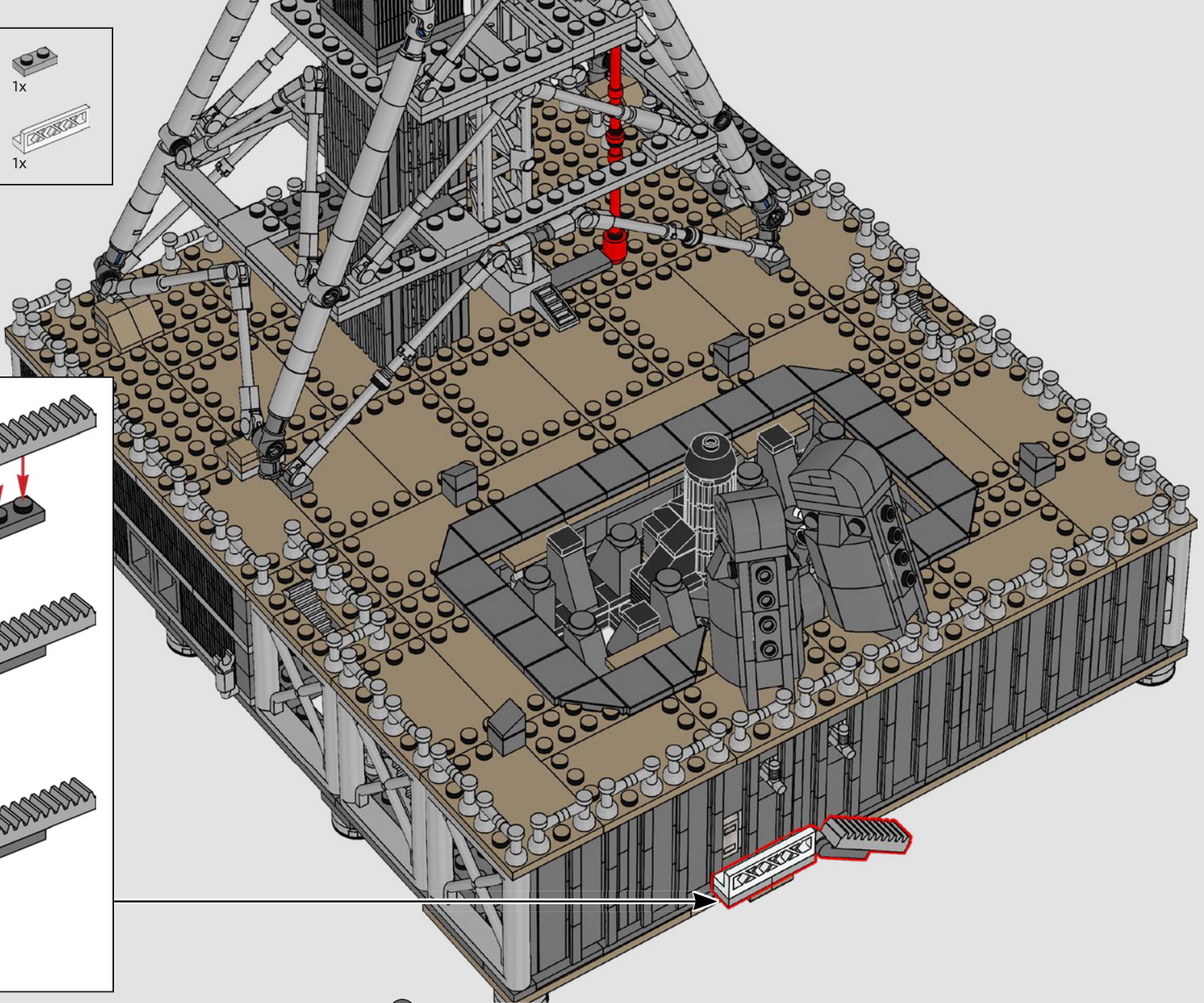
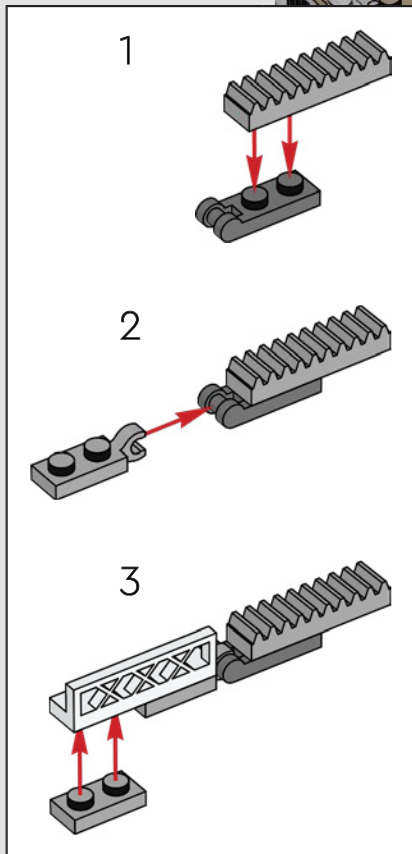

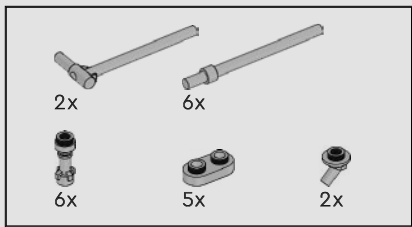

429

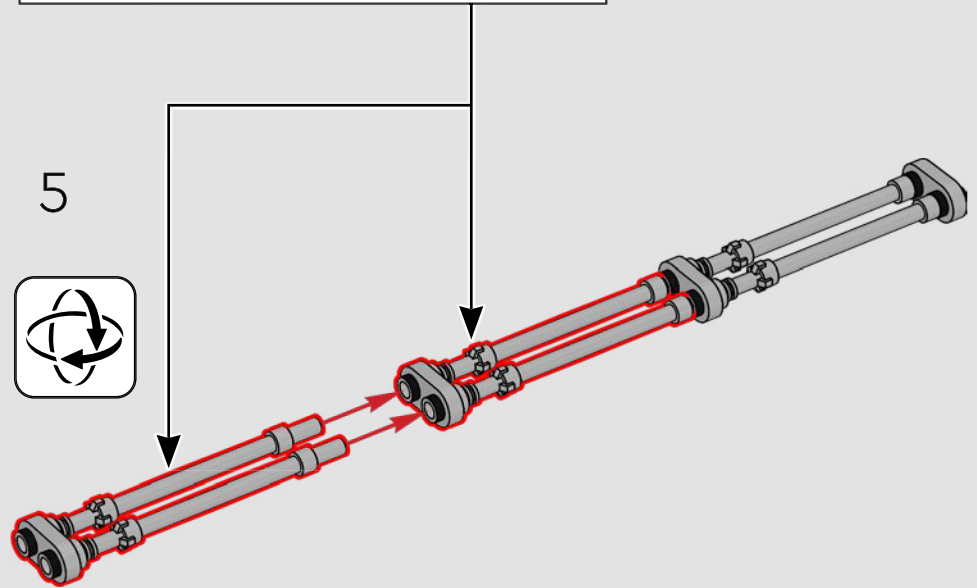
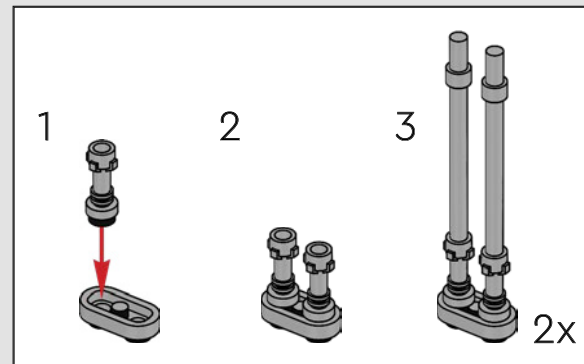
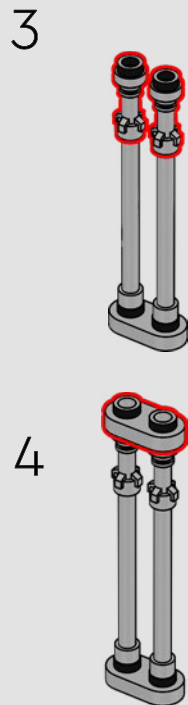
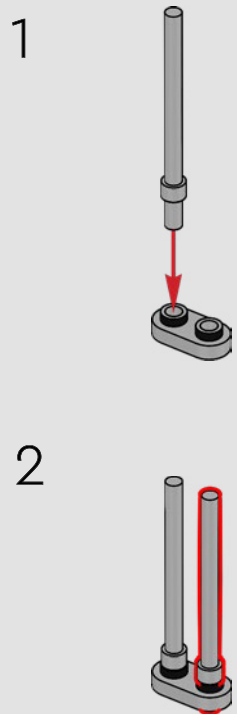

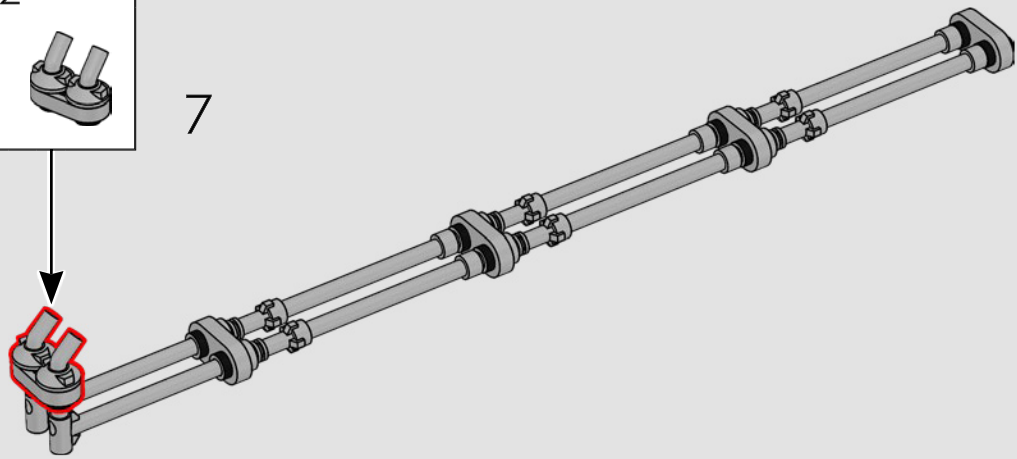
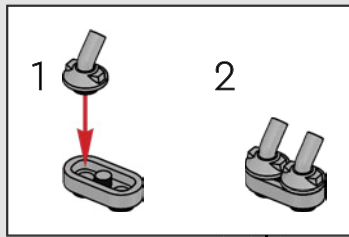
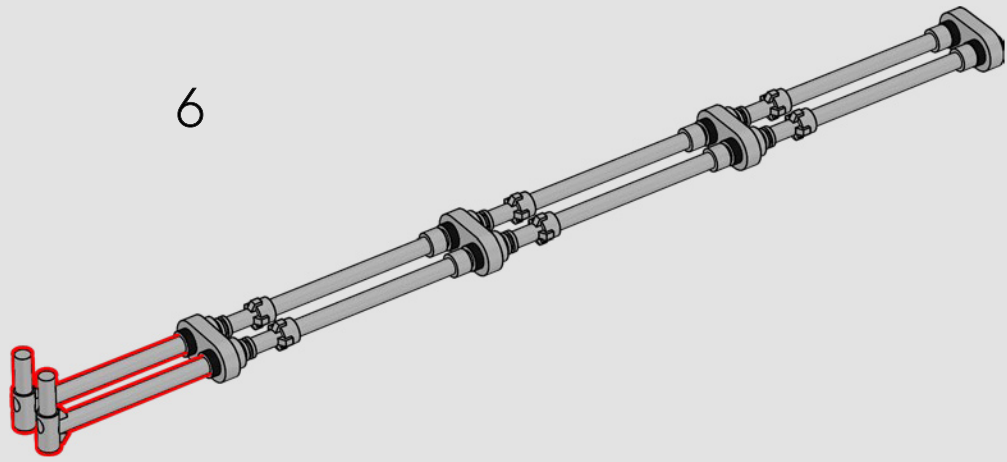

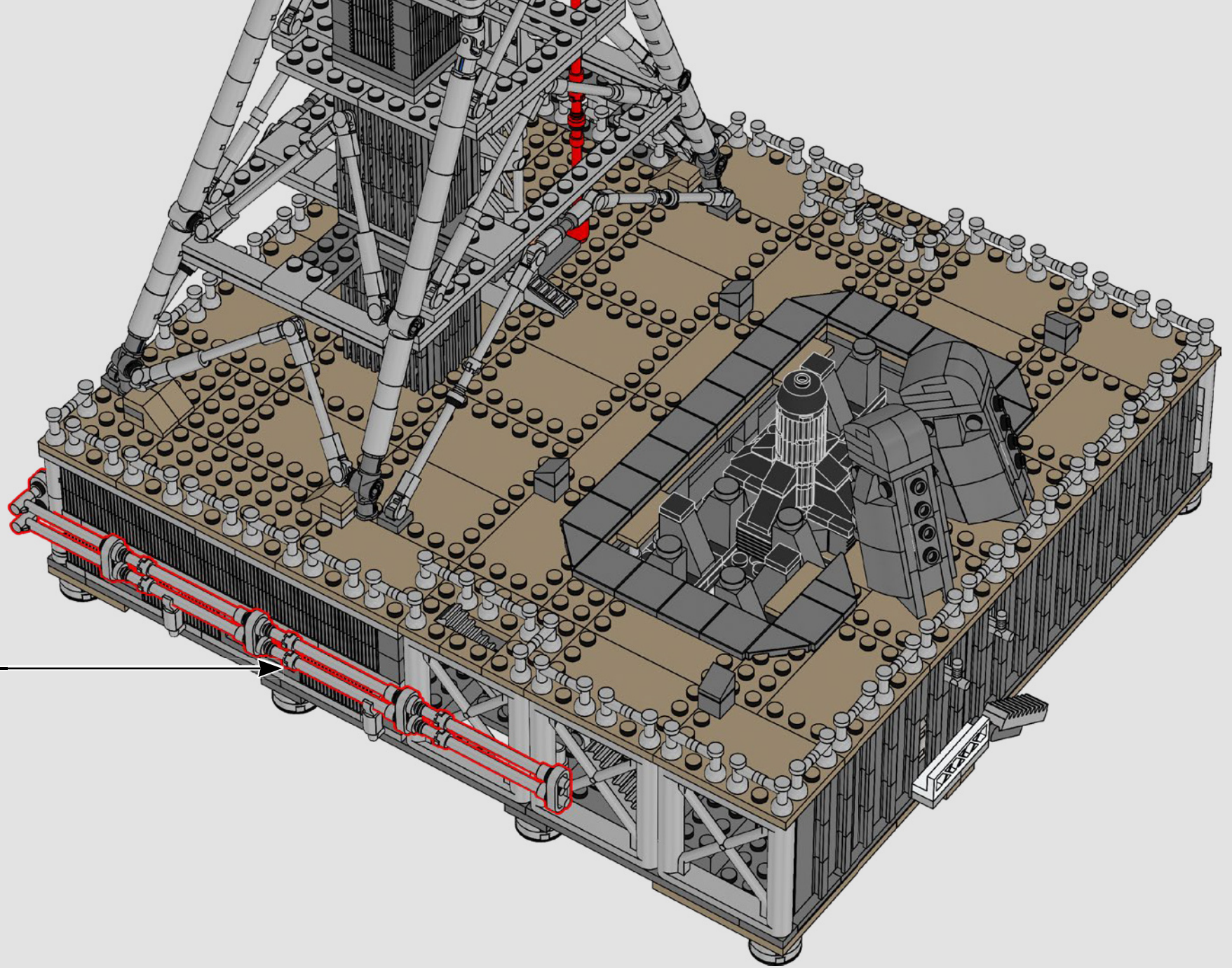



430

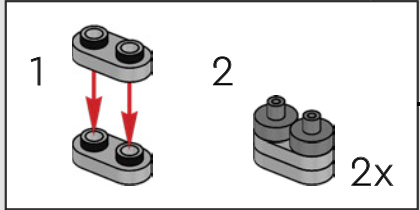
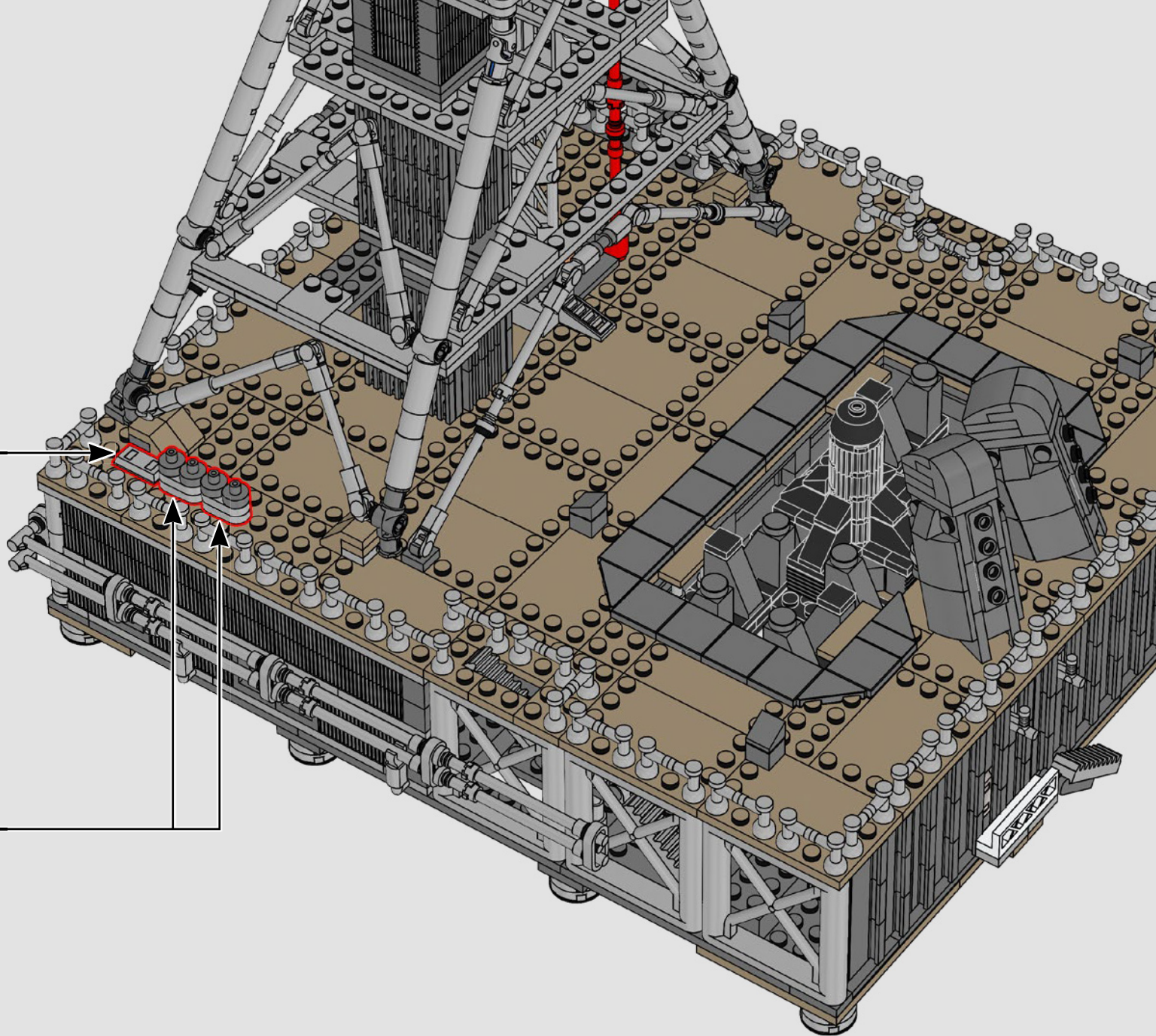
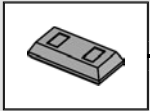

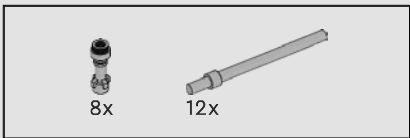

431

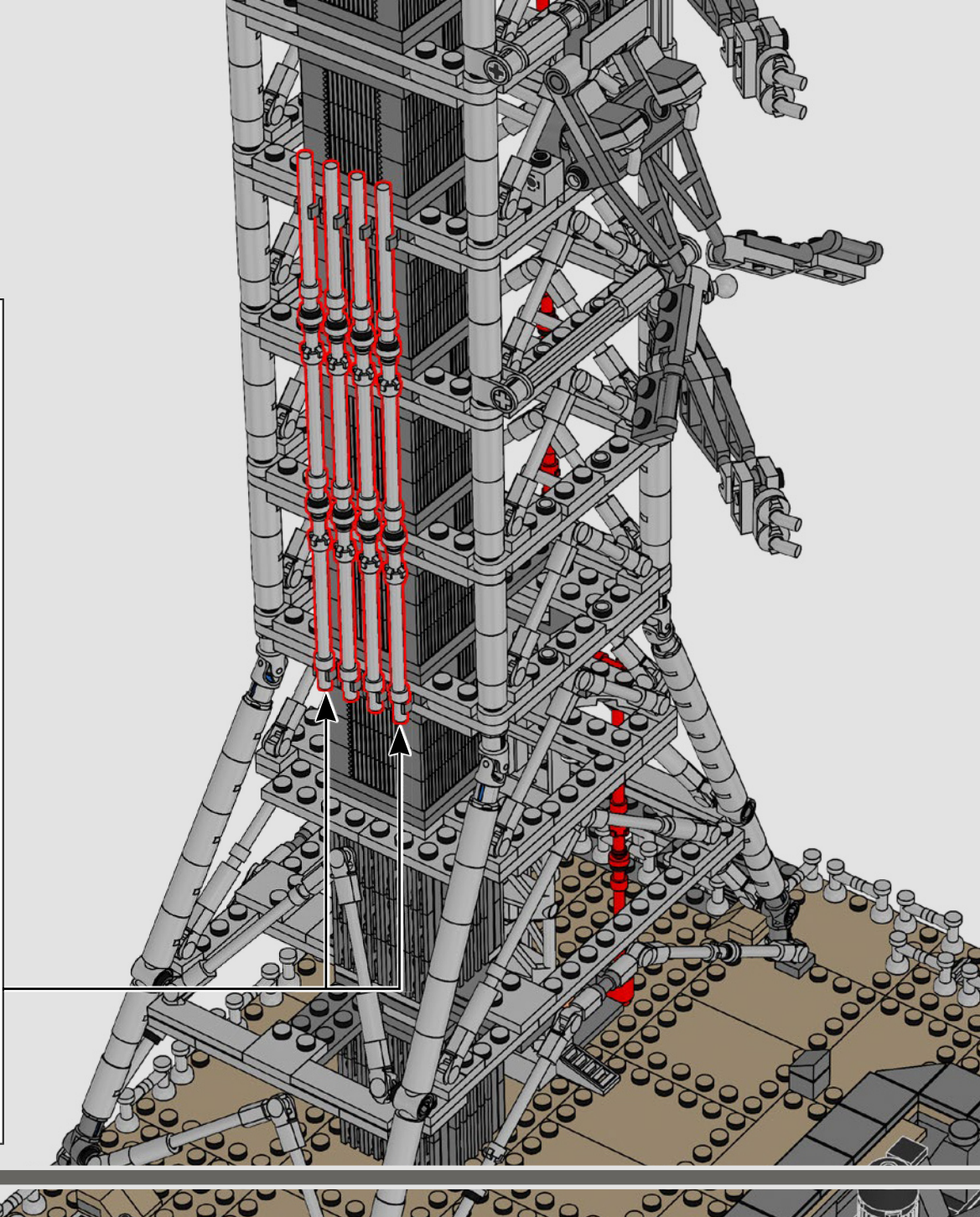
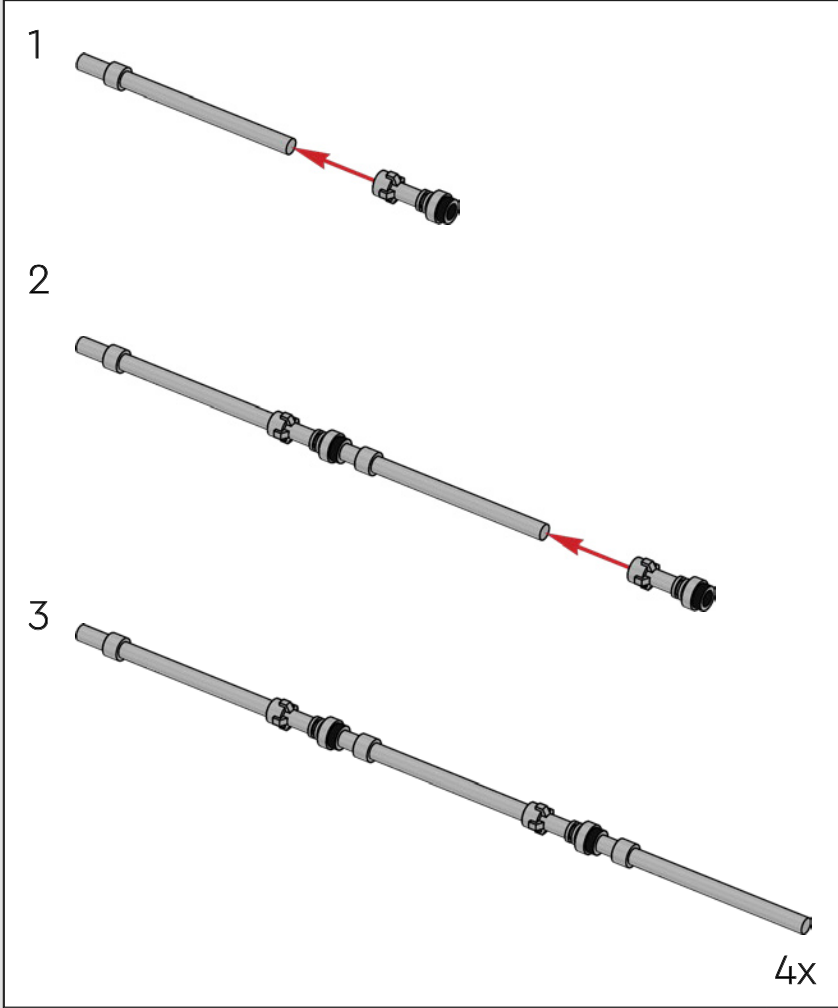

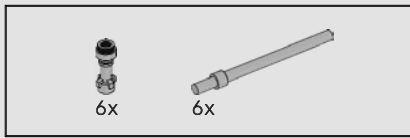

432

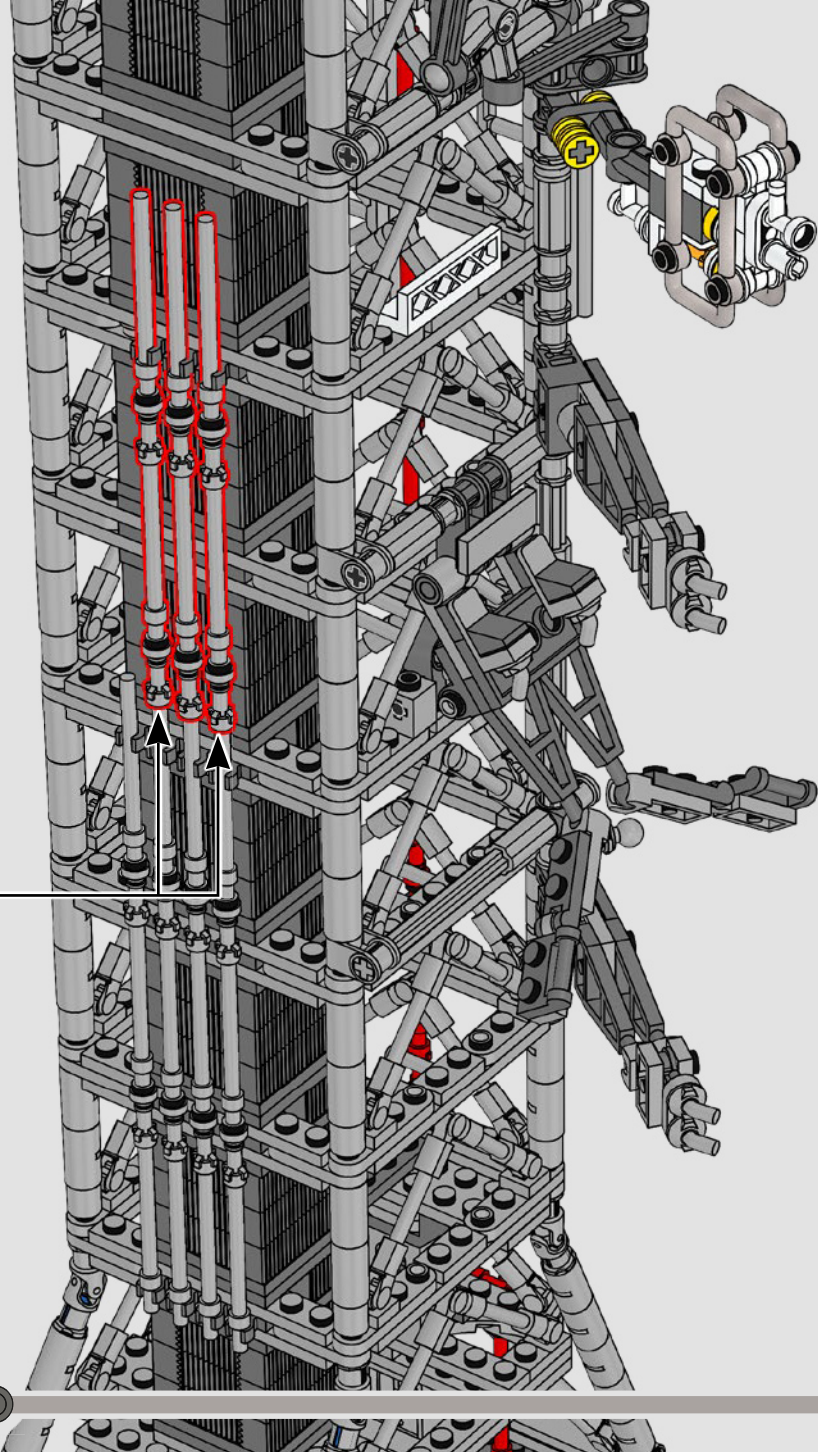
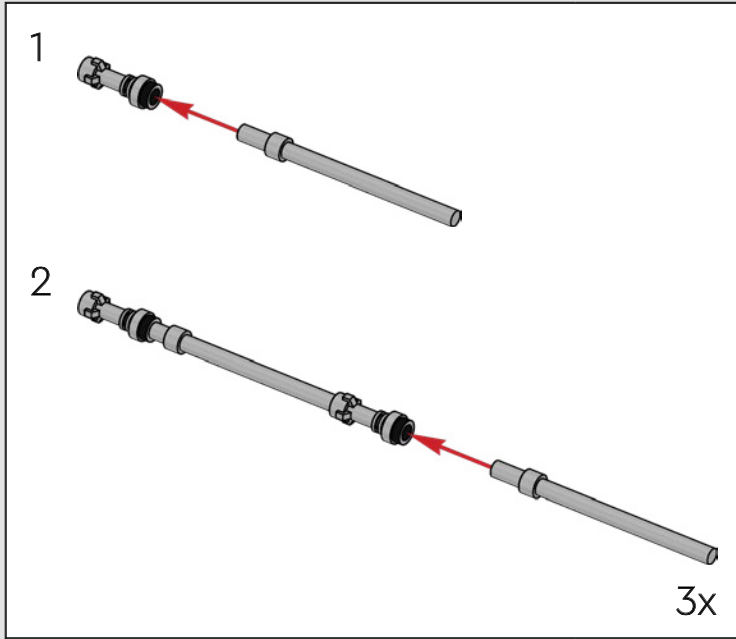

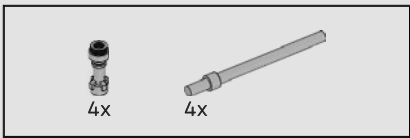

433

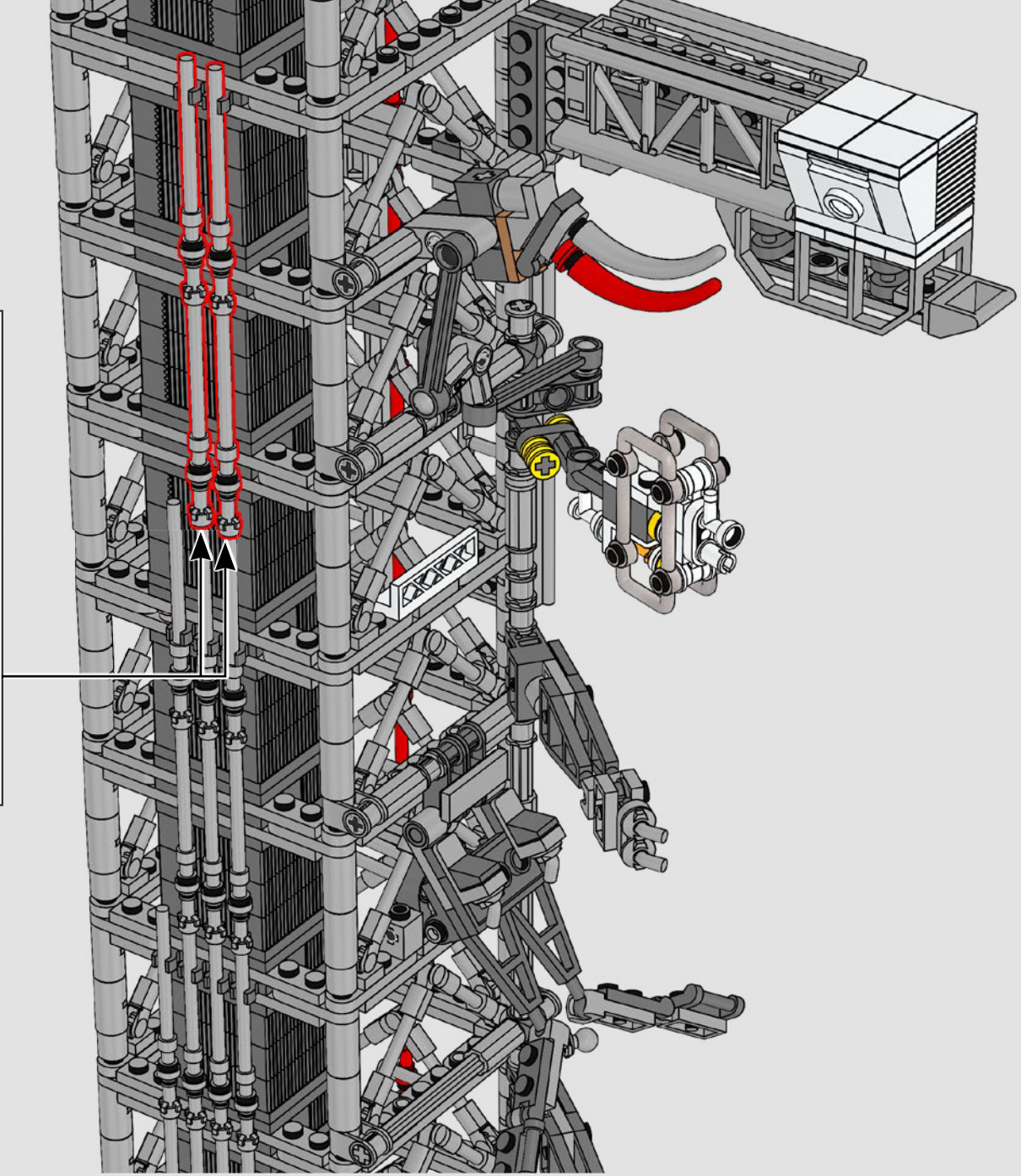
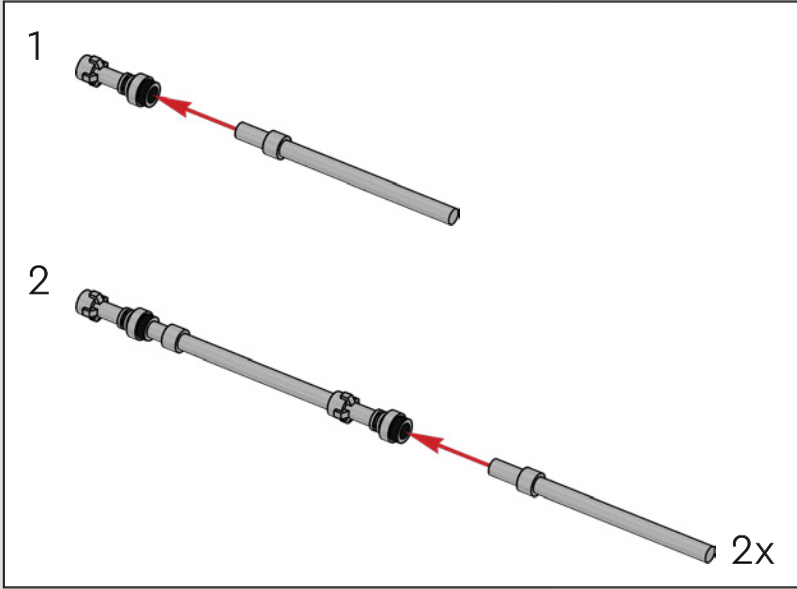

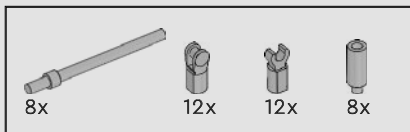

434

1

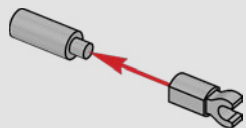

2

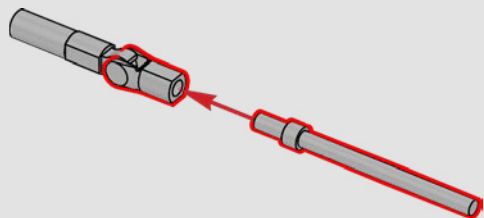

3

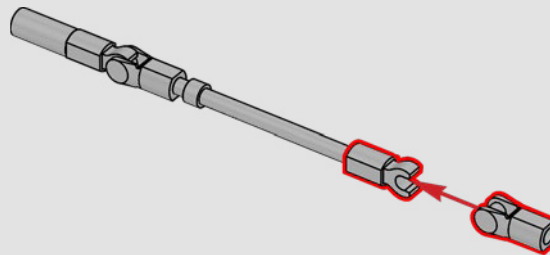

4

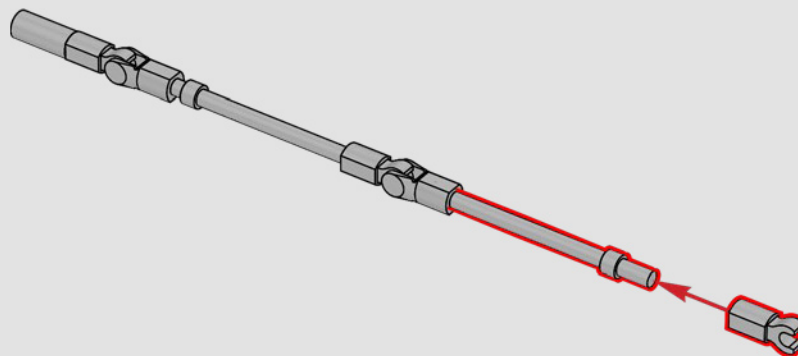

5

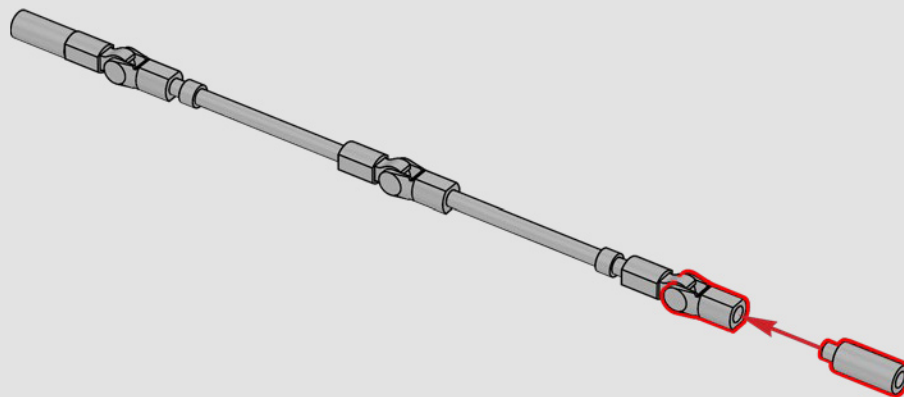

4x

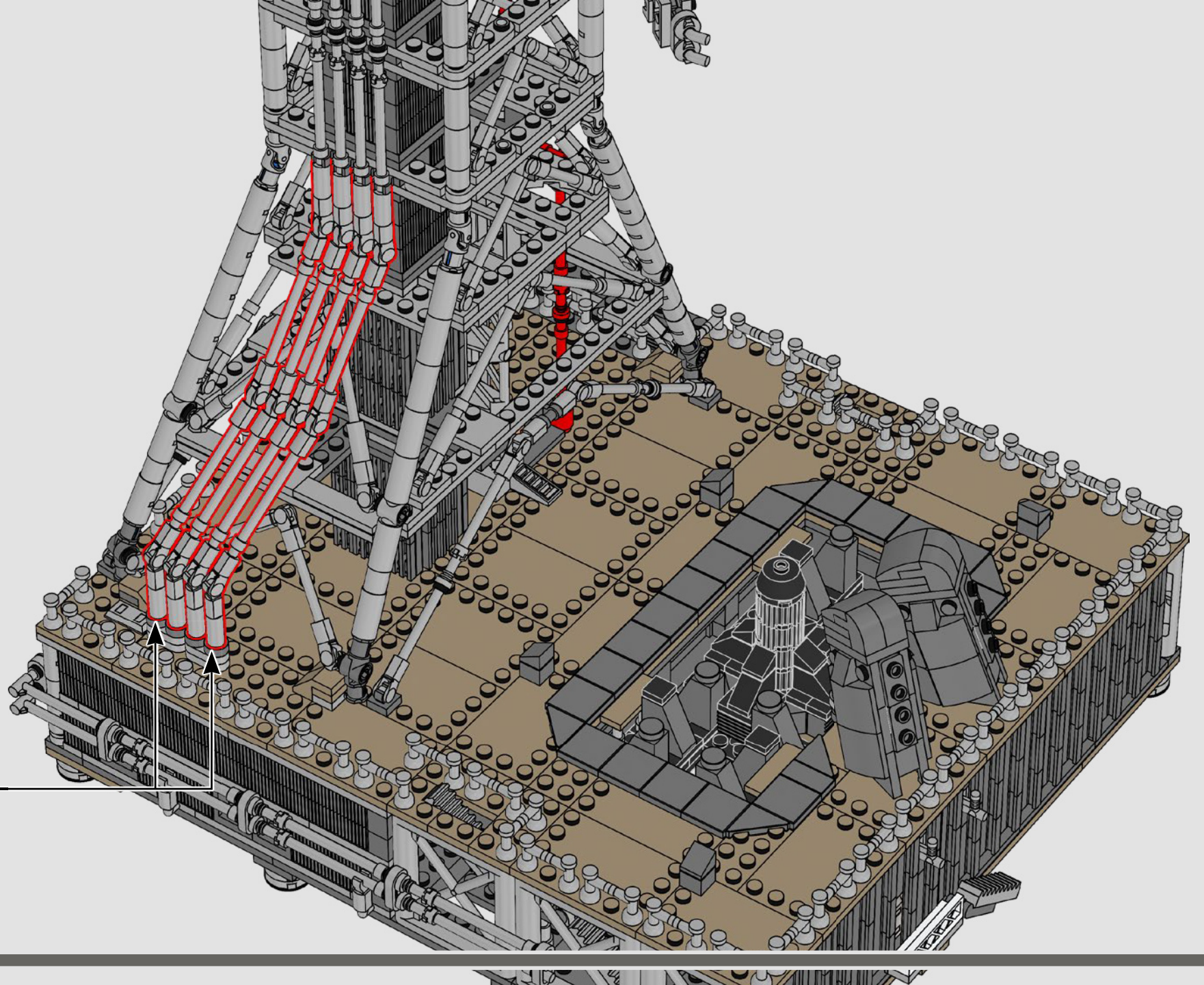

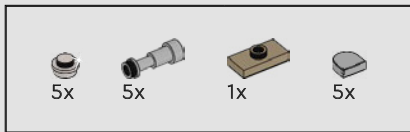

435

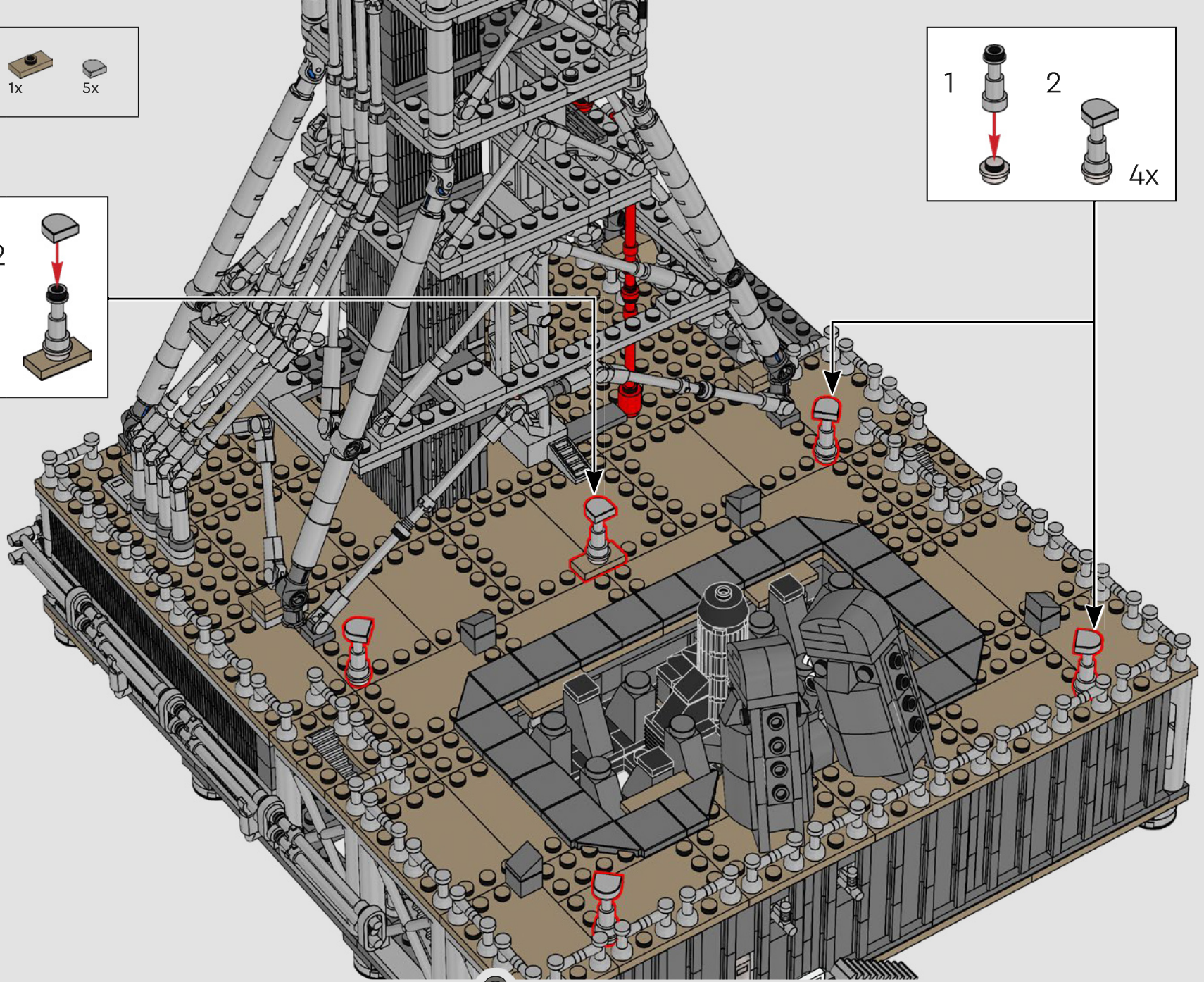
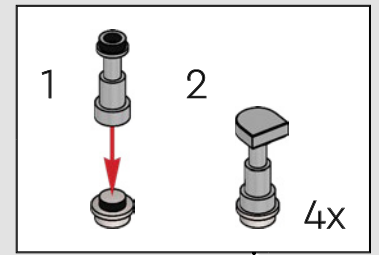
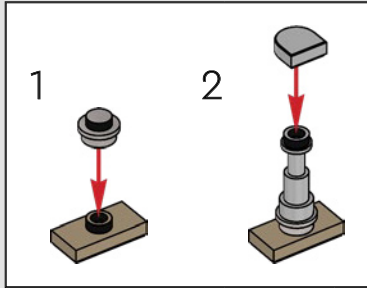

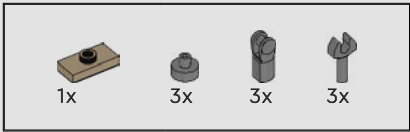

436

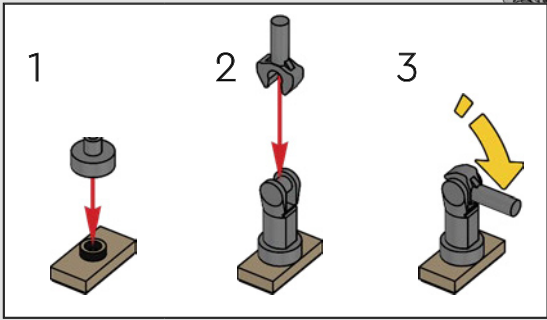
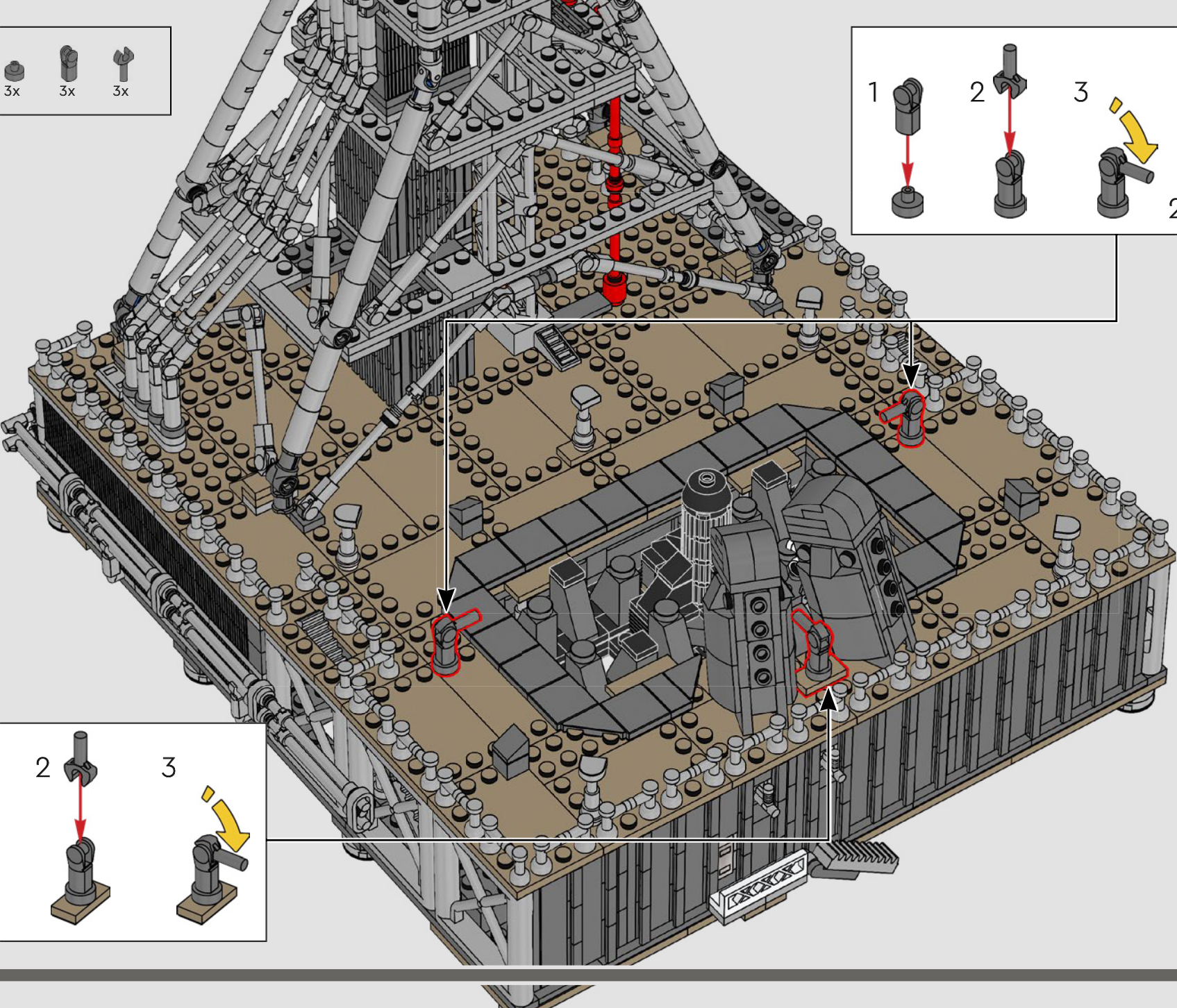
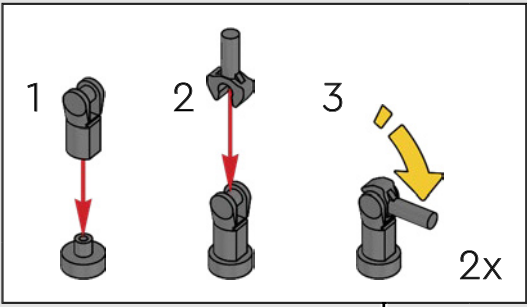

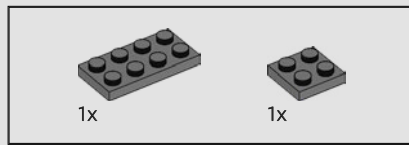

437

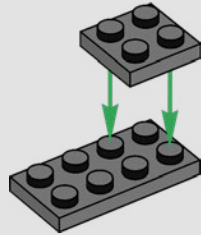

438

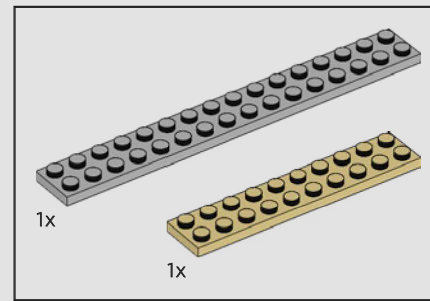
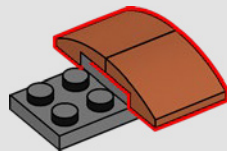

439

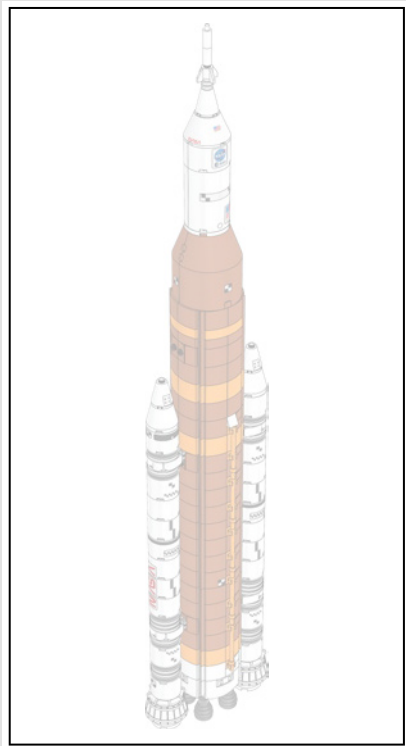
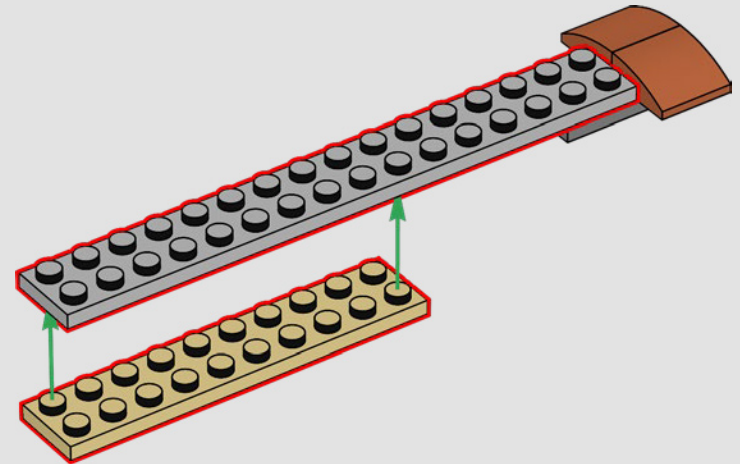

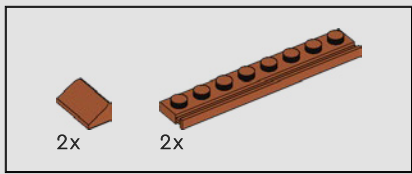

440

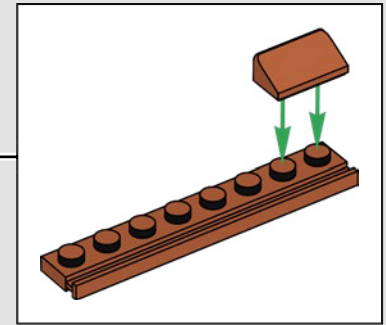
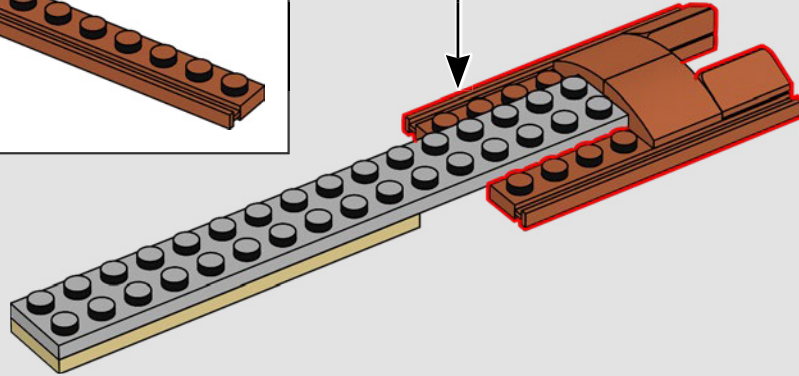
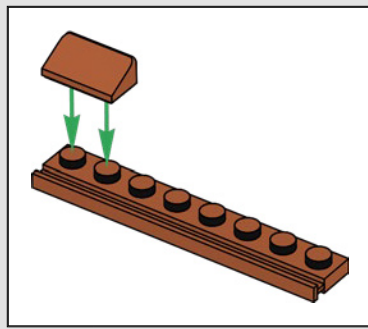

441

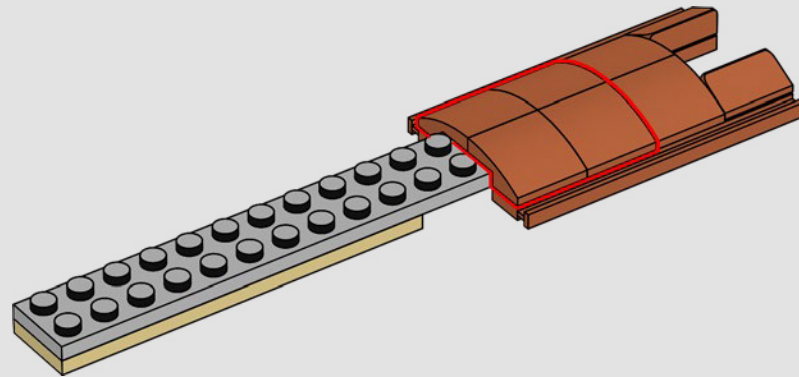

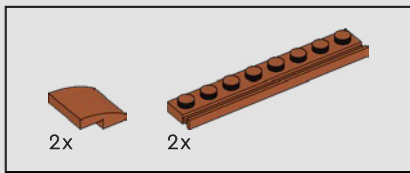

442

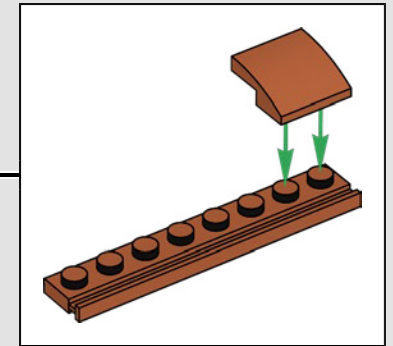
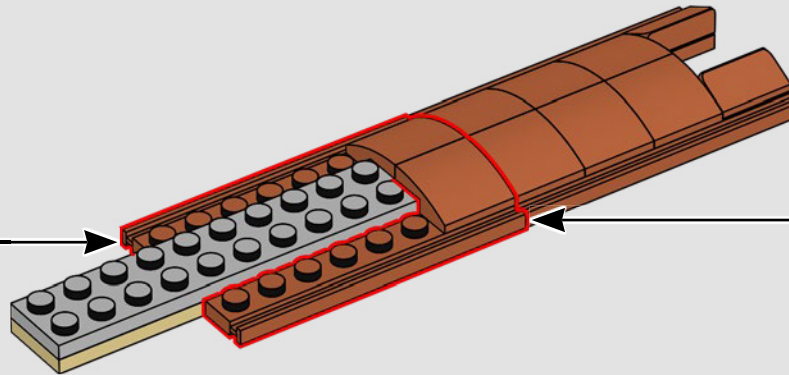
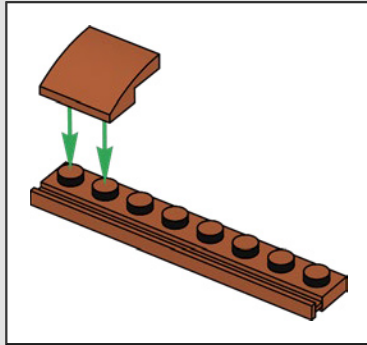

443

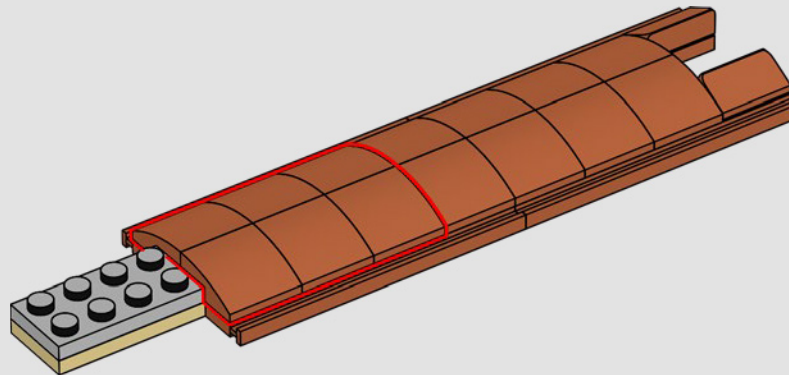

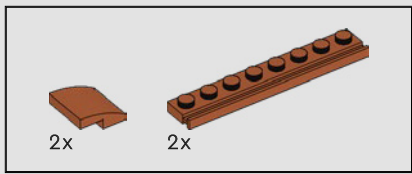

444

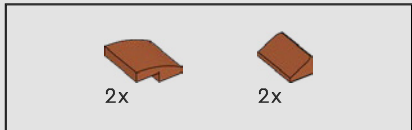
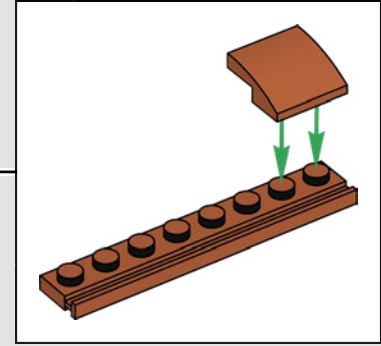
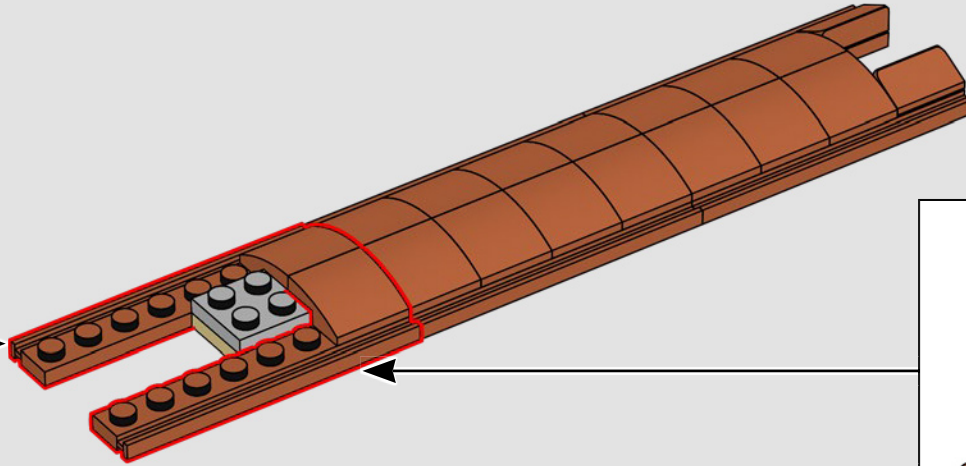
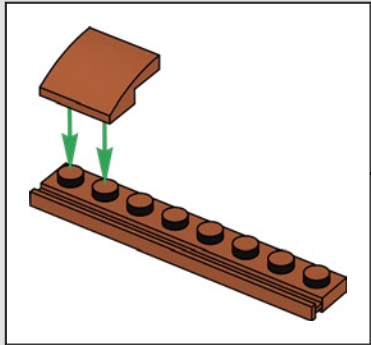

445

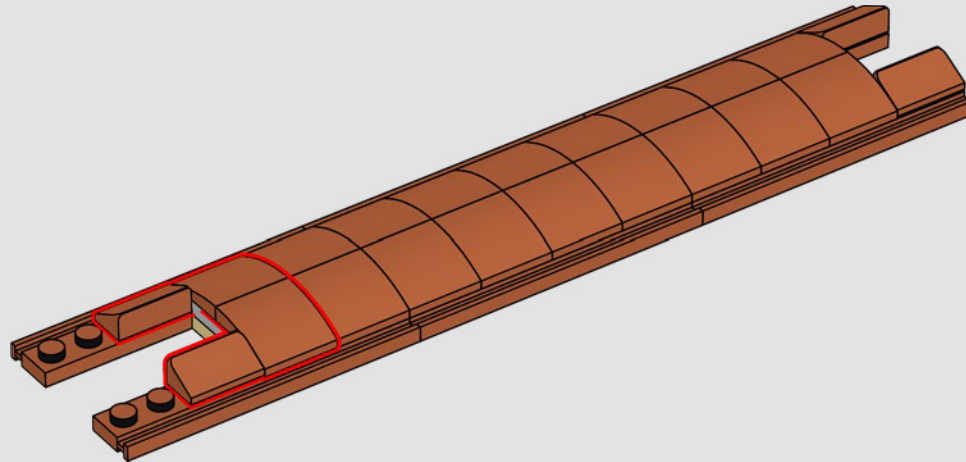

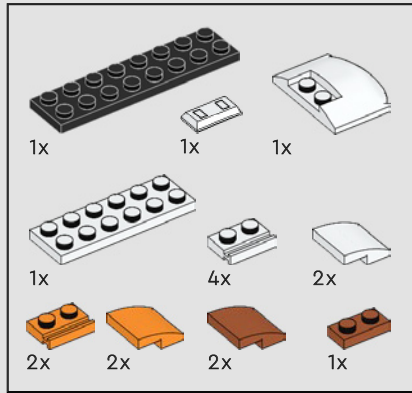
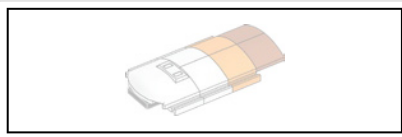

446

1

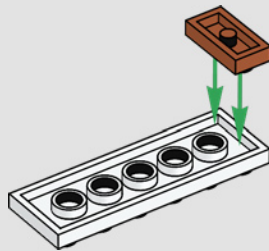

2

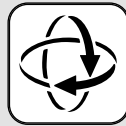
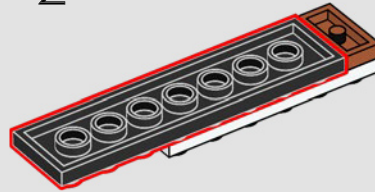

3

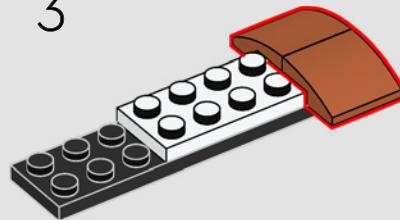

4

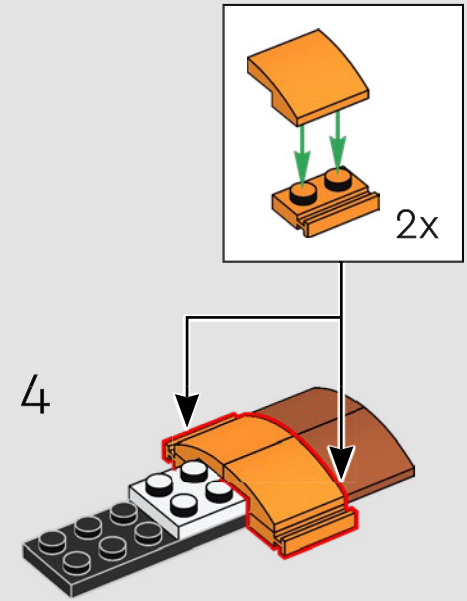

5

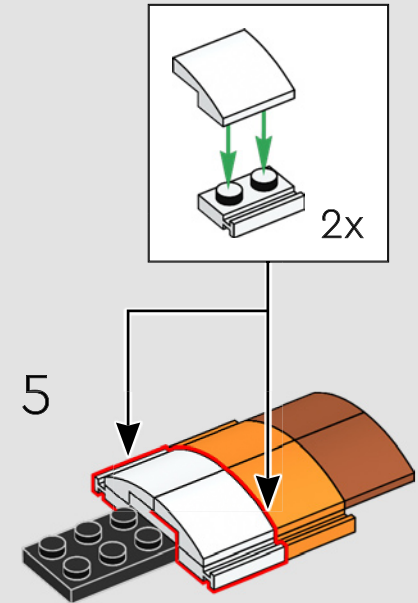

6

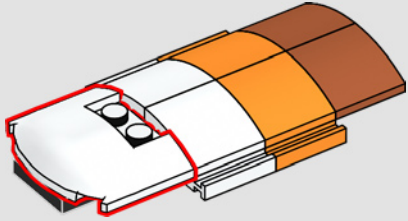

8

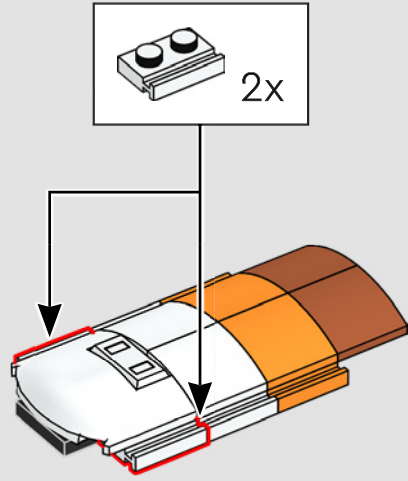

7

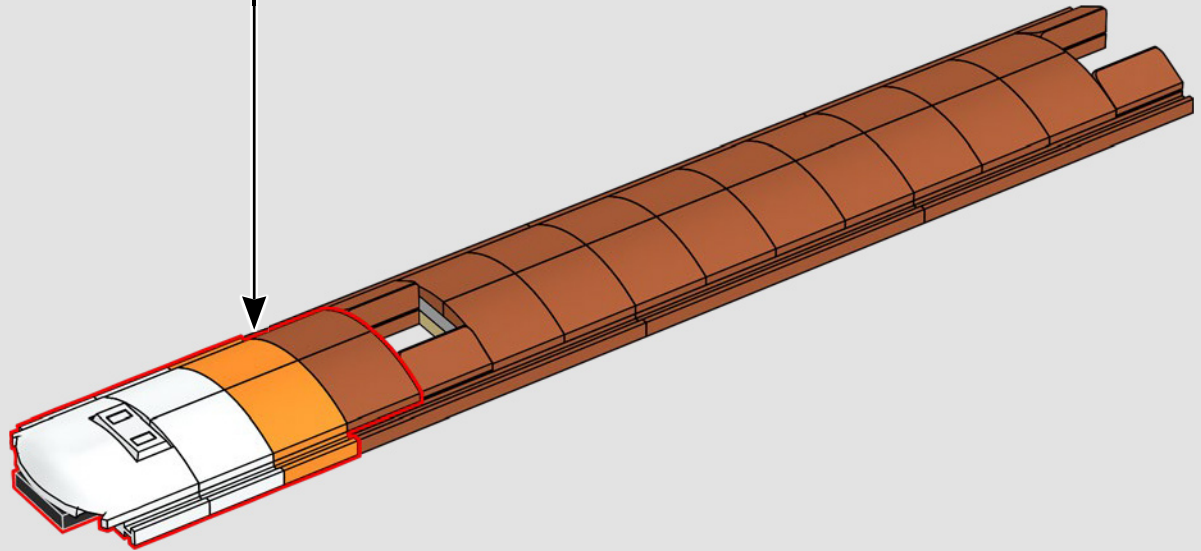
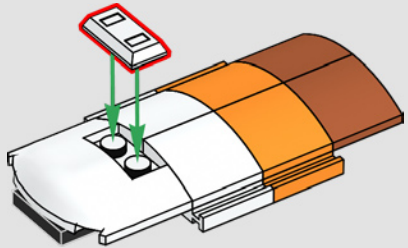

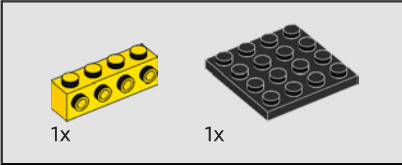
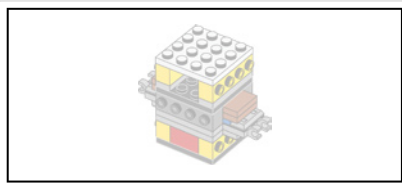

447

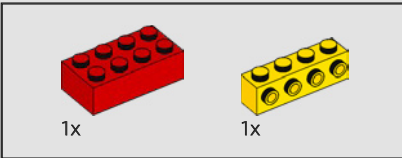
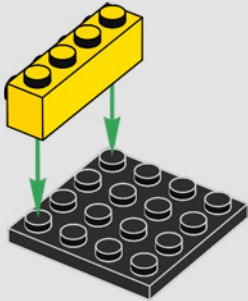

448

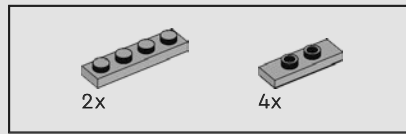
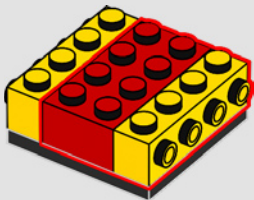

449

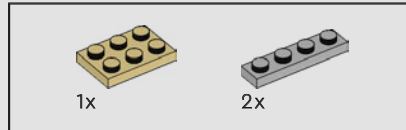

450

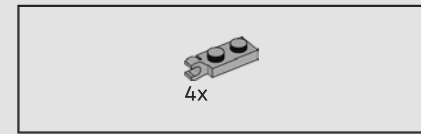
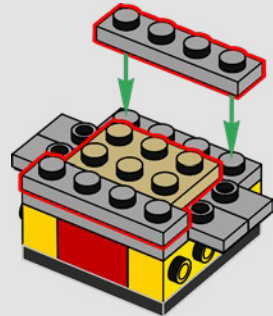

451

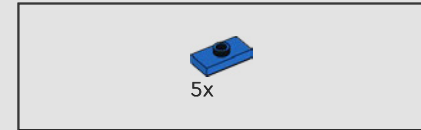
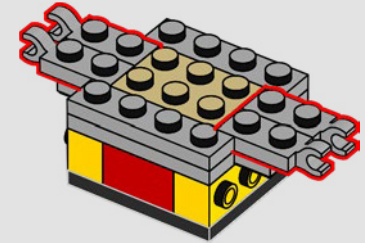

452

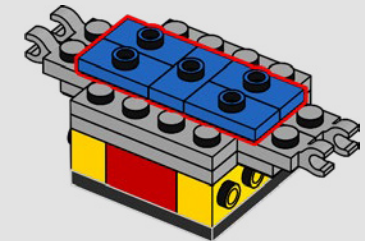

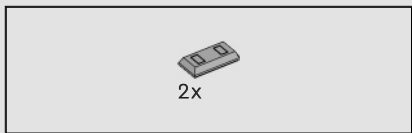

453

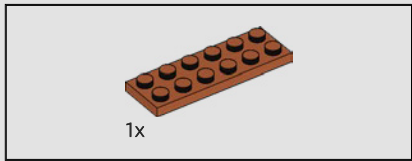
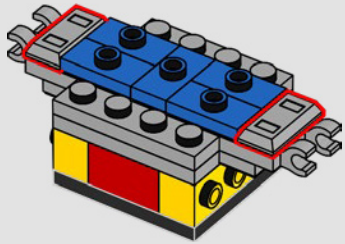

454

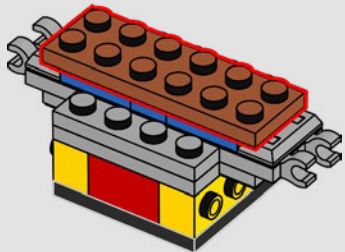

455

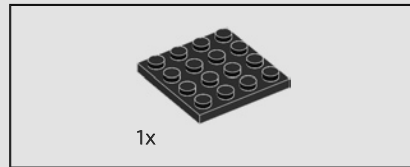
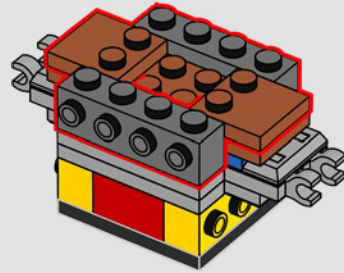

456

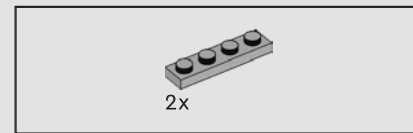
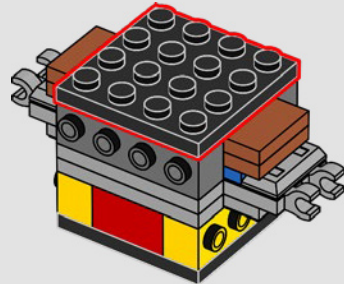

457

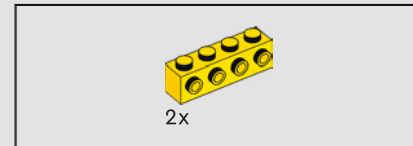
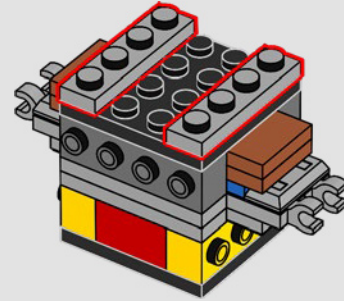

458

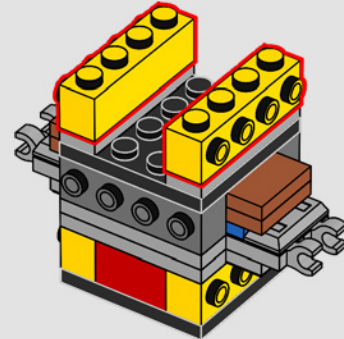

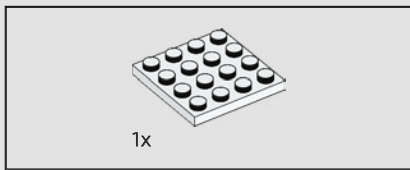

459

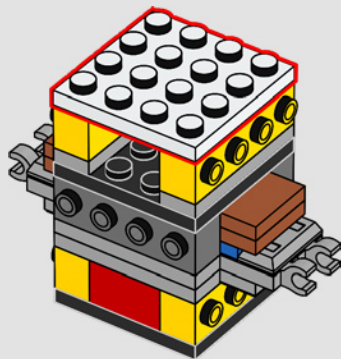

460

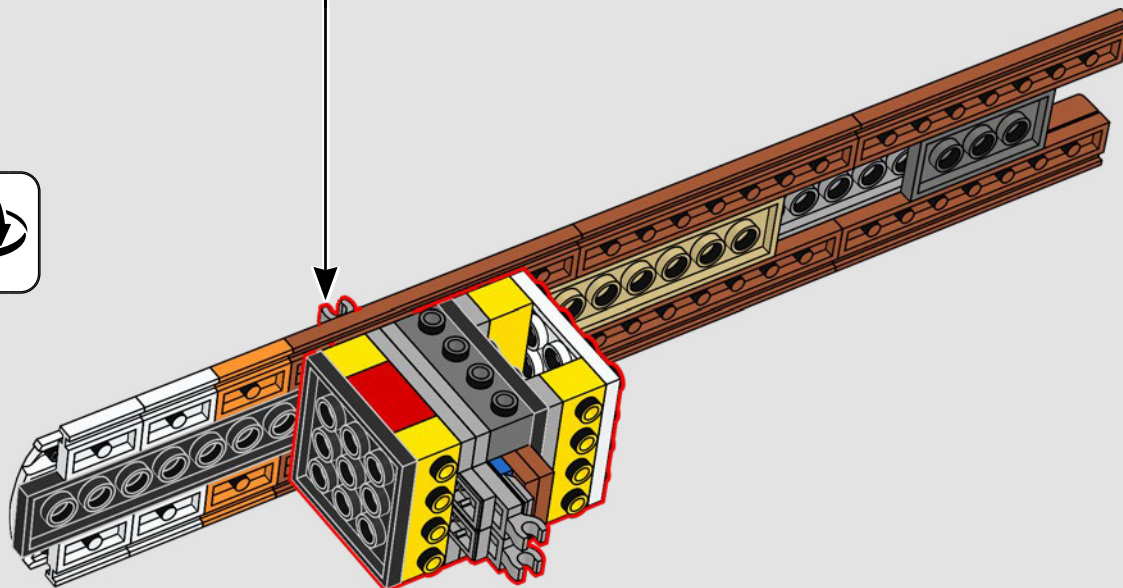

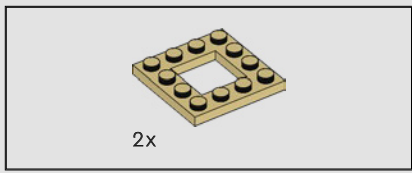

461

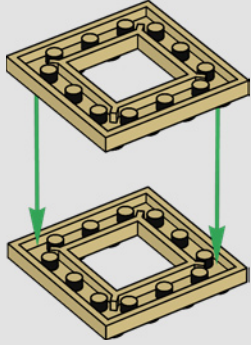

462

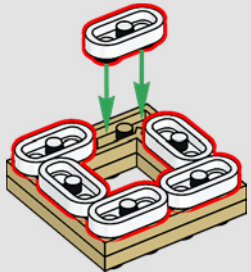

463

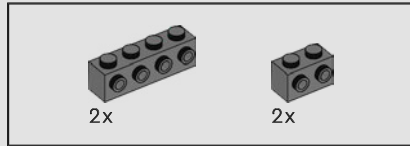
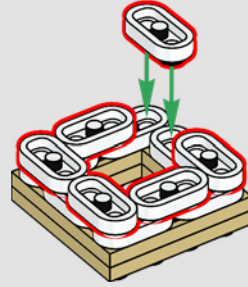

464

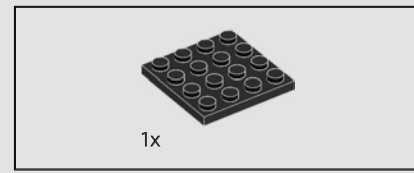
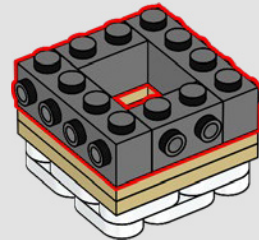
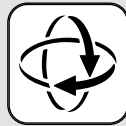

465

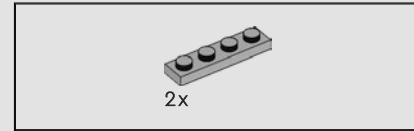
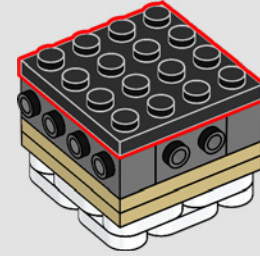

466

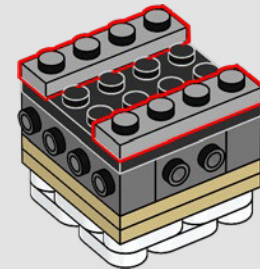

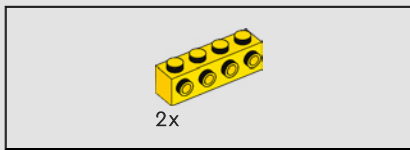

467

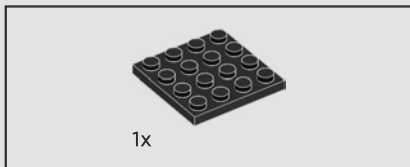
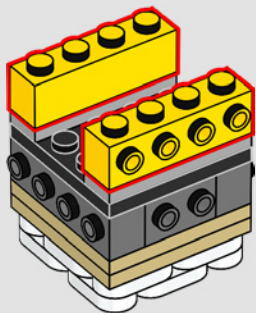

468

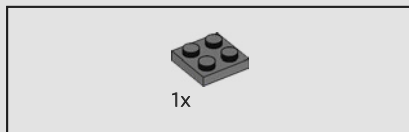
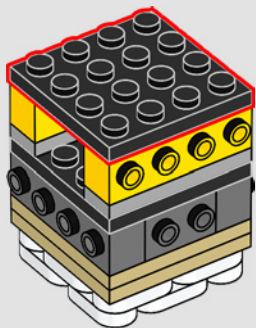

469

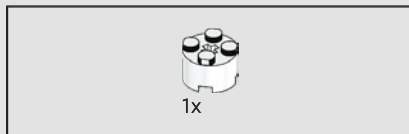
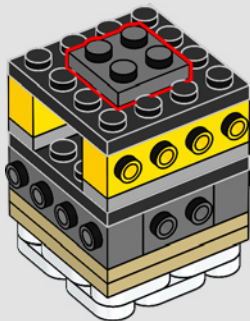

470

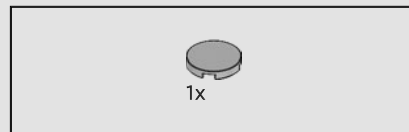
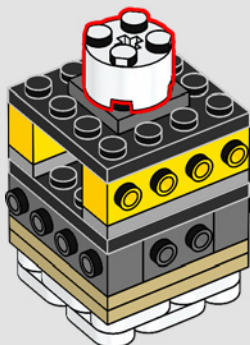

471

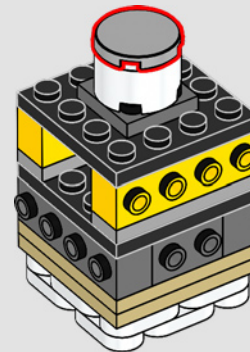

472

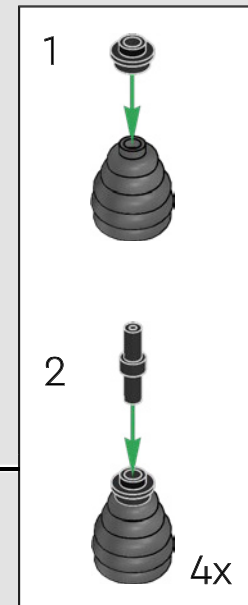
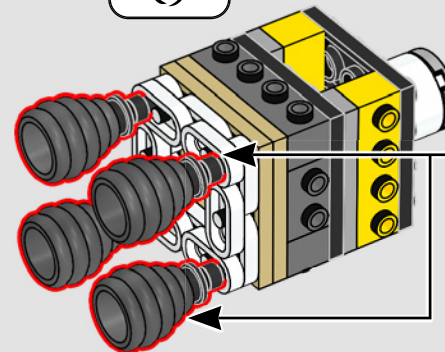
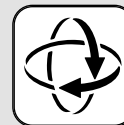

Das LEGO® Element, das für die Haupttriebwerksdüsen verwendet wird, stellte ursprünglich einen Bienenstock dar, wird aber als „Mini-Mütze Nr. 54“ bezeichnet.

473

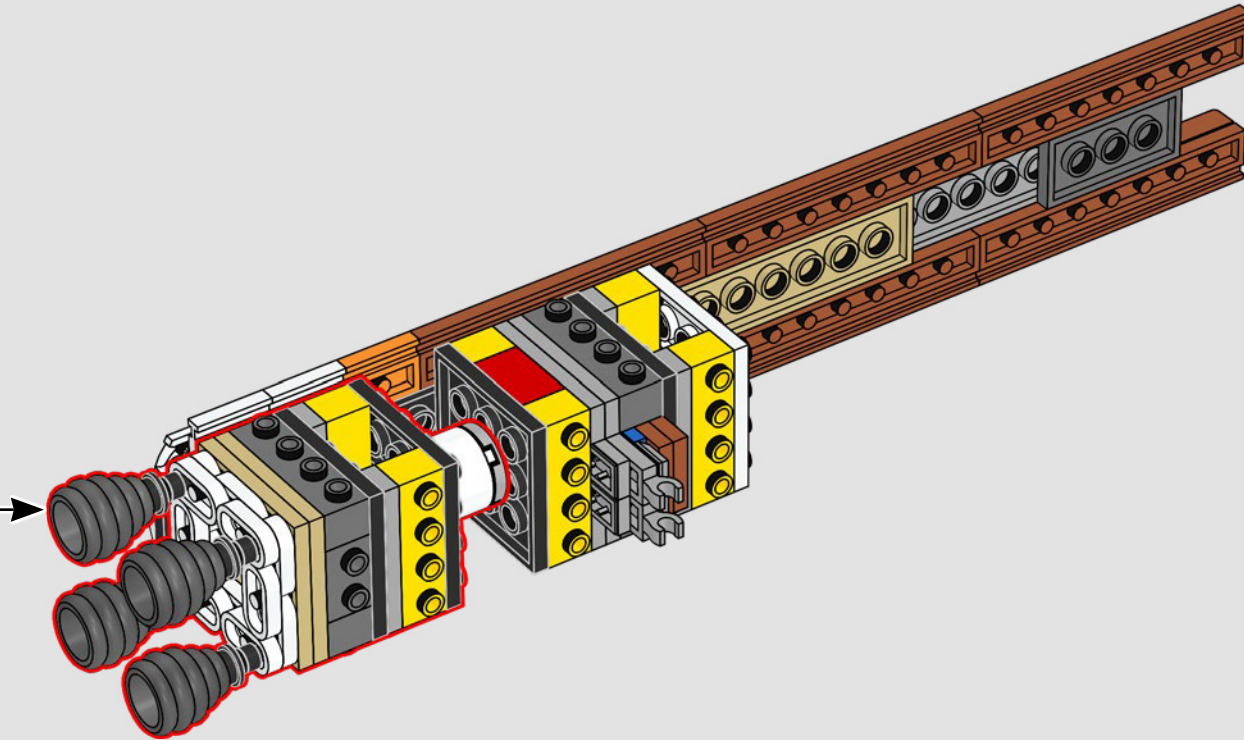

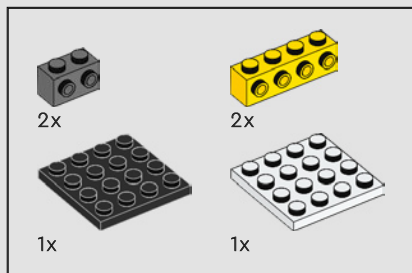

474

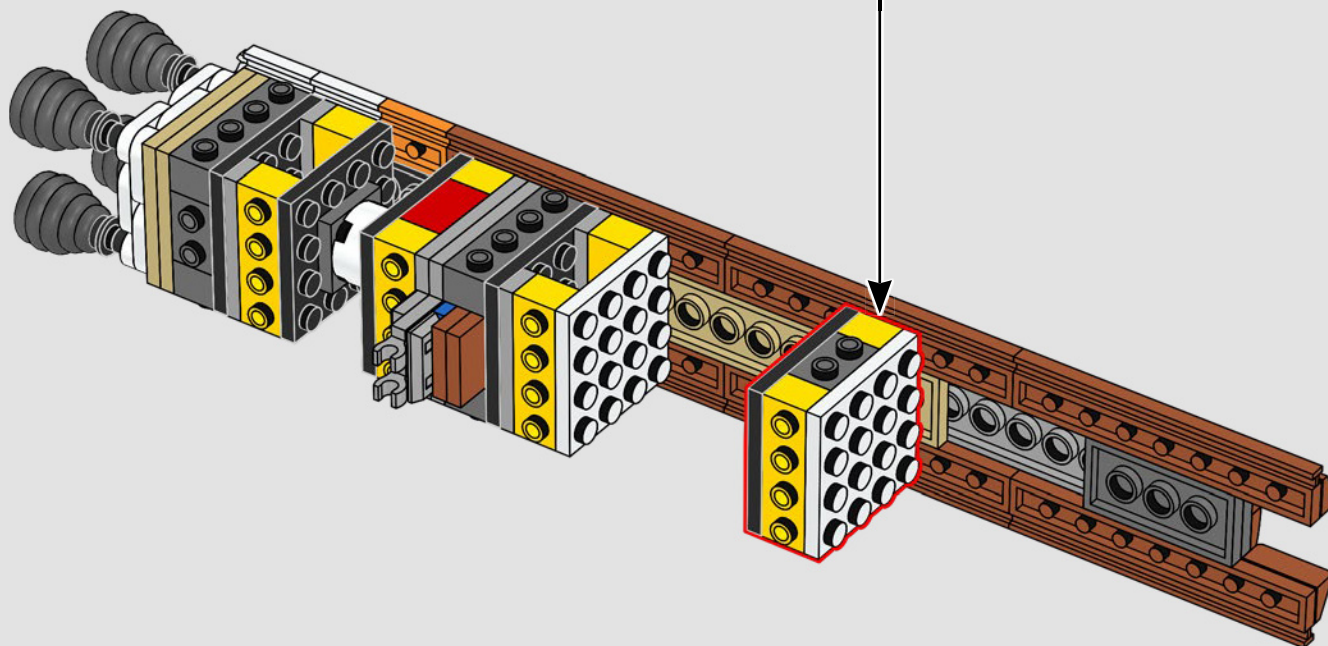
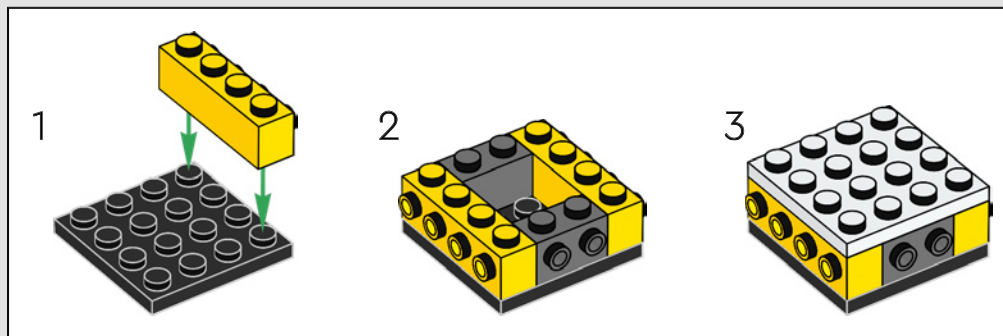

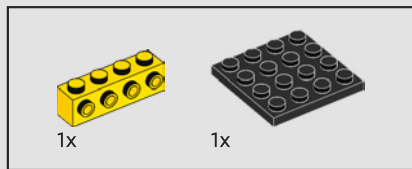

475

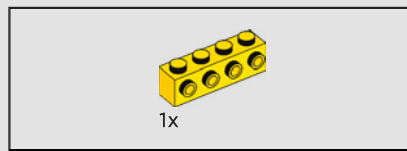
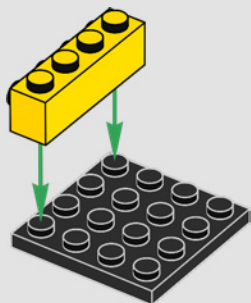

476

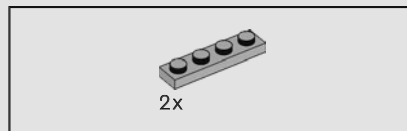
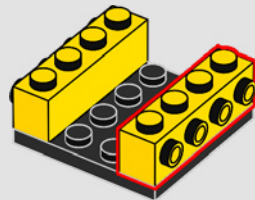

477

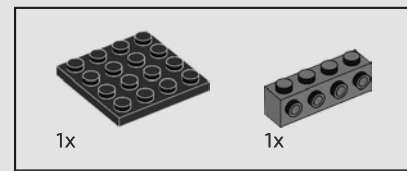
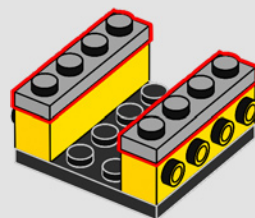

478

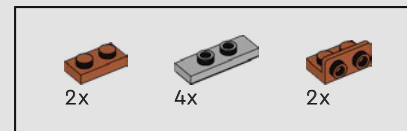
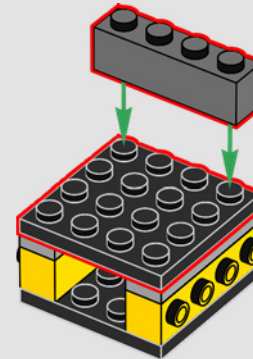

479

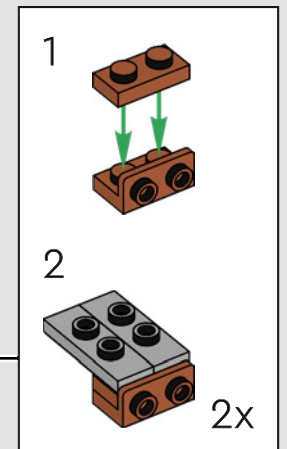
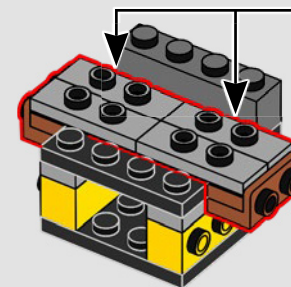

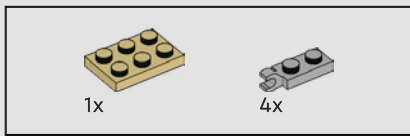

480

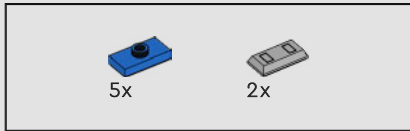
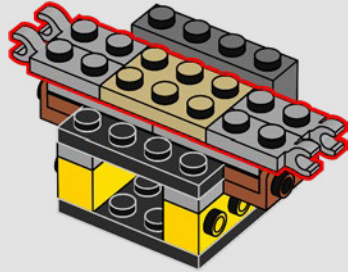

481

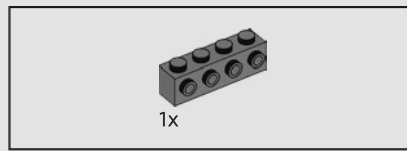
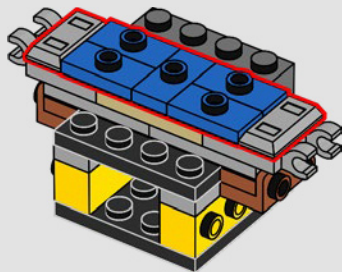

482

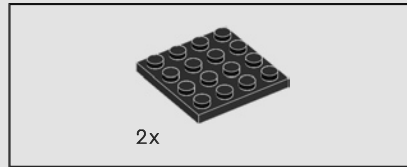
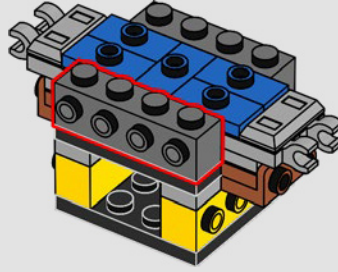

483

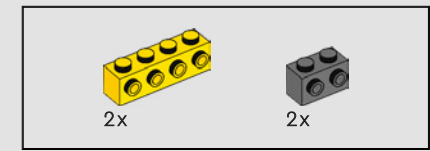
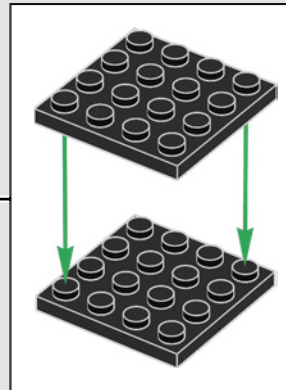
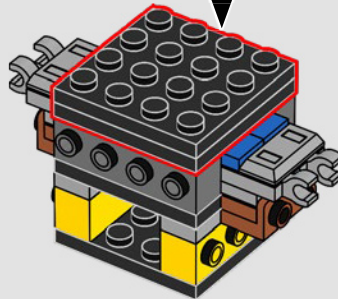

484

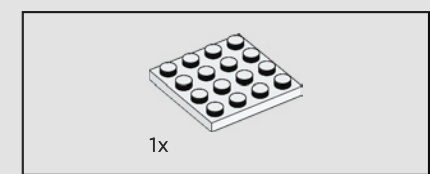
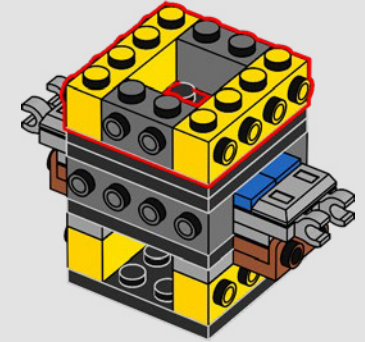

485

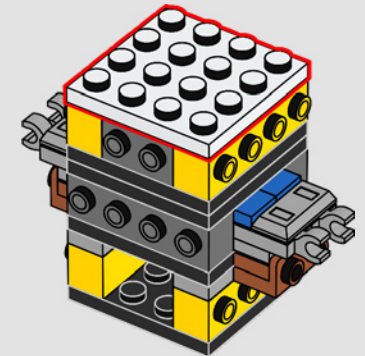

486

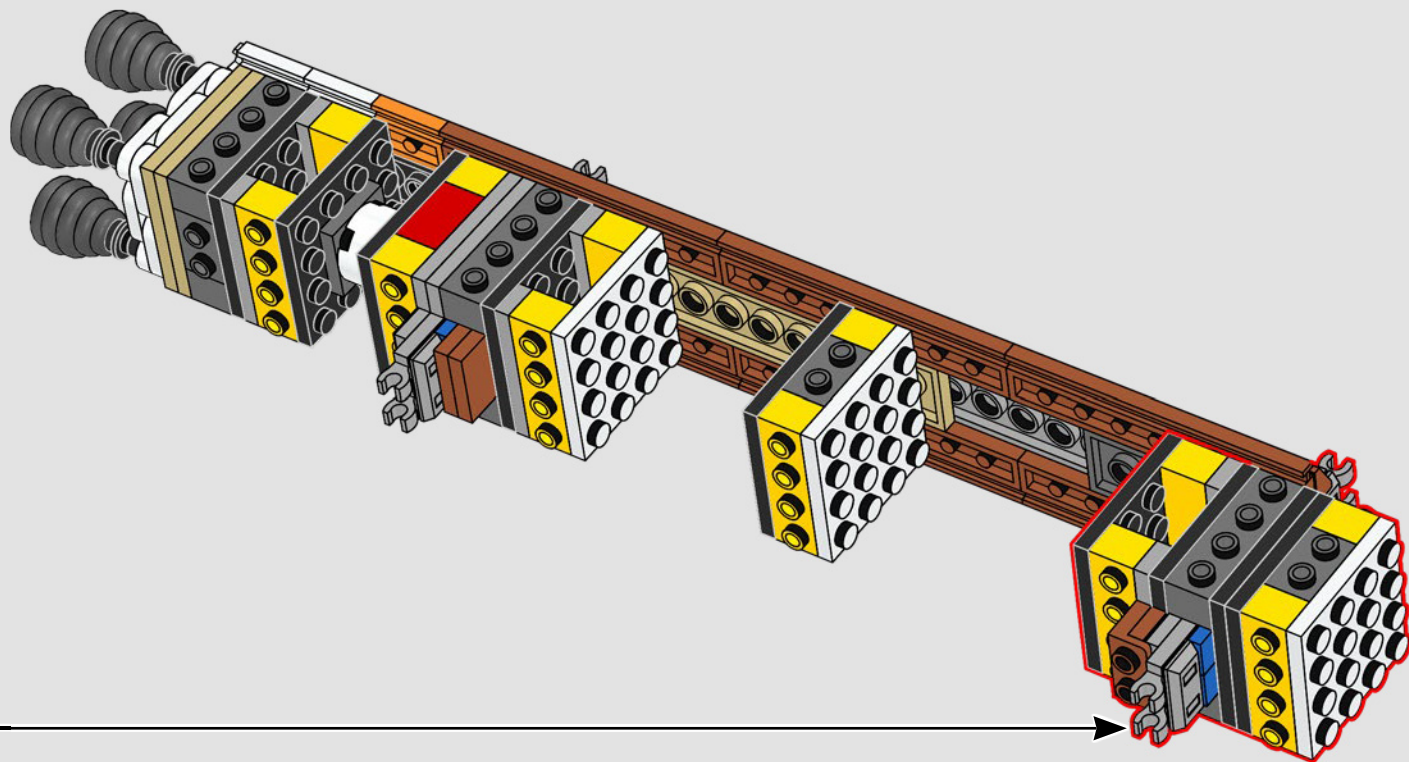

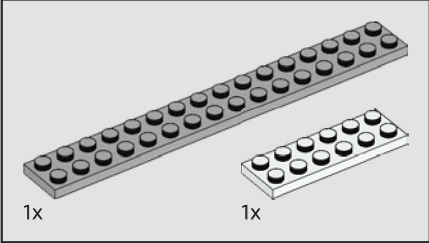
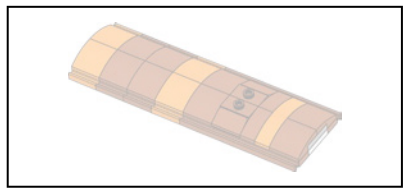

487

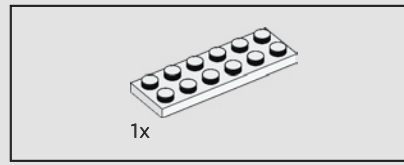
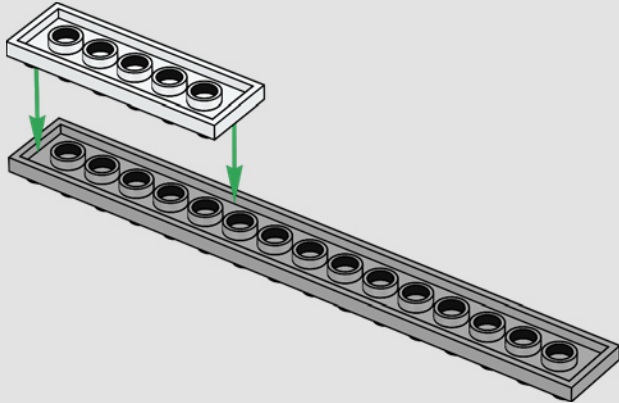

488

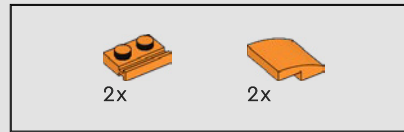
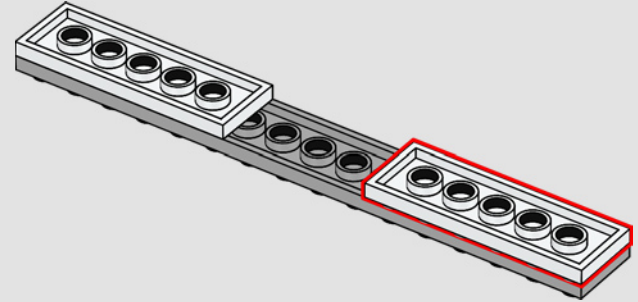

489

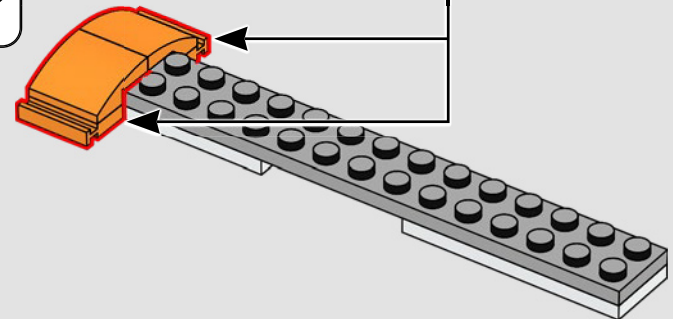
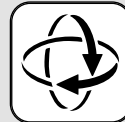
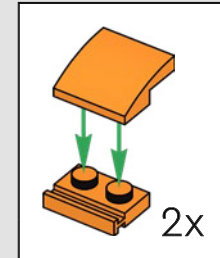

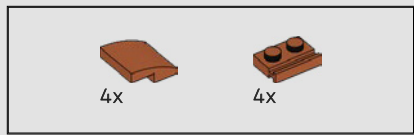

490

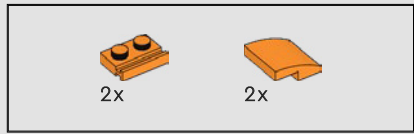
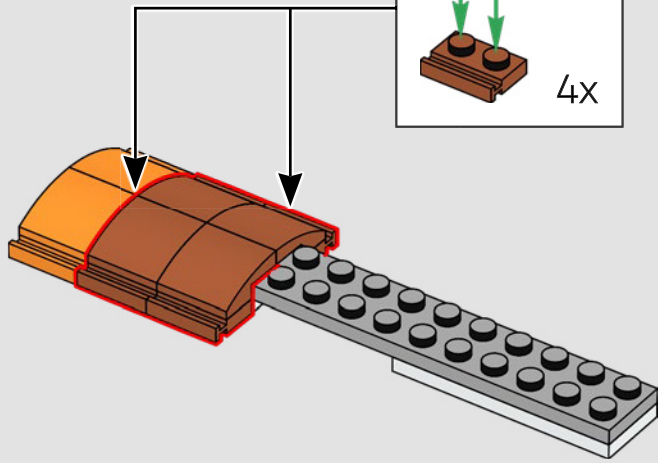
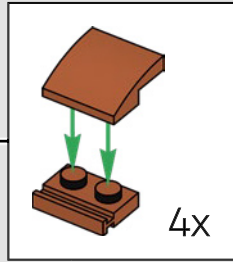

491

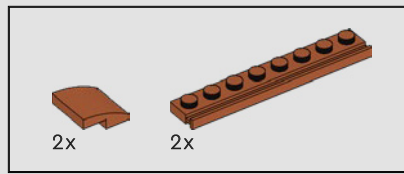
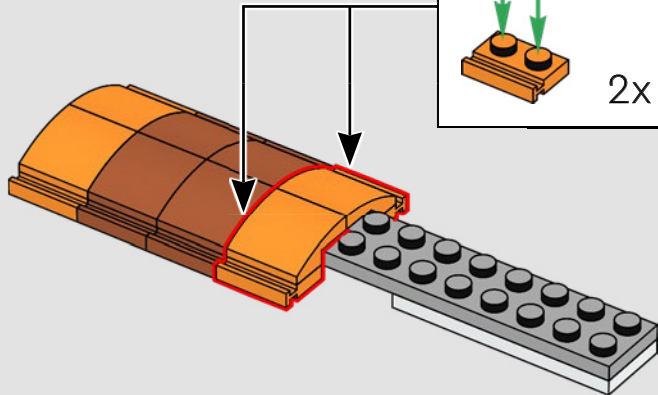
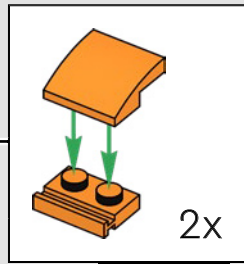

492

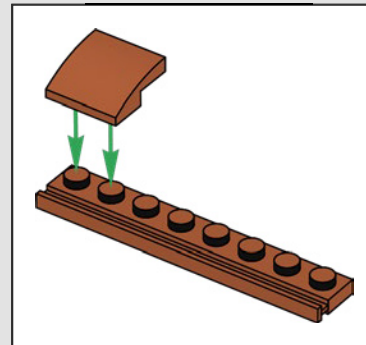
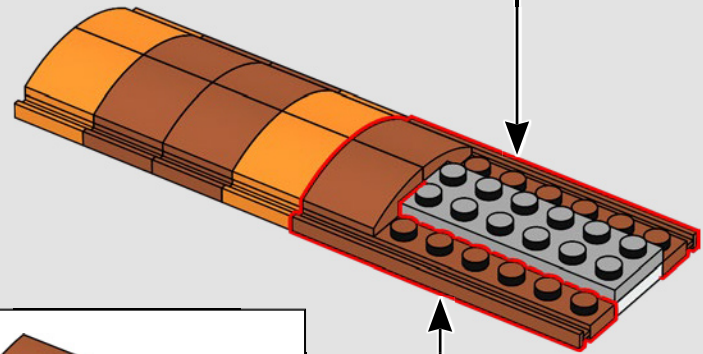
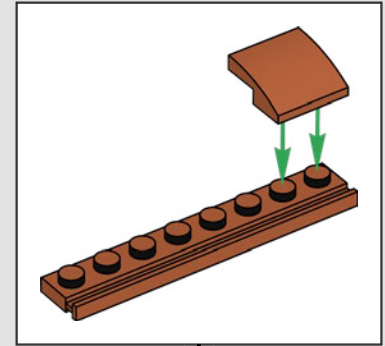

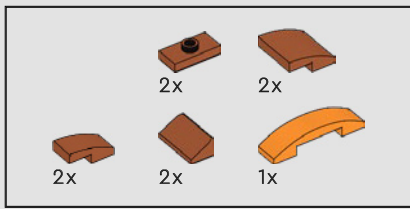

493

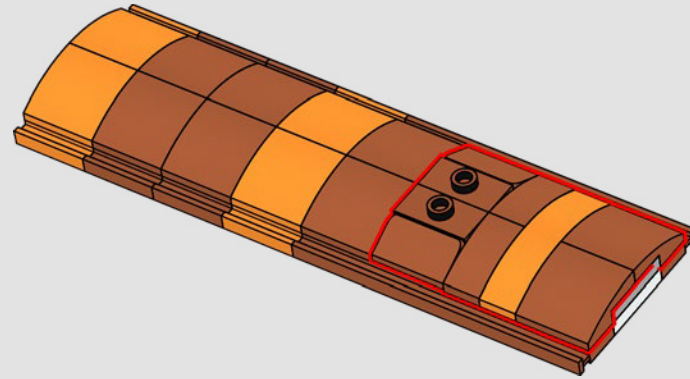

494

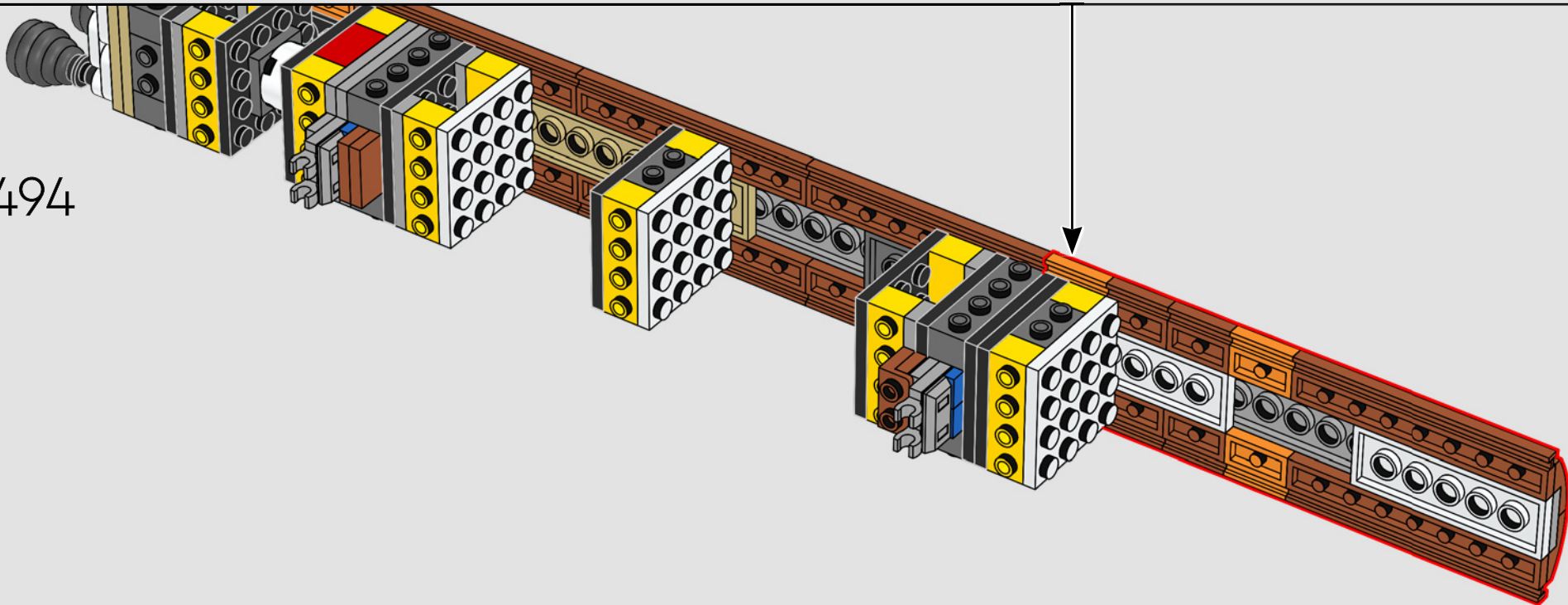

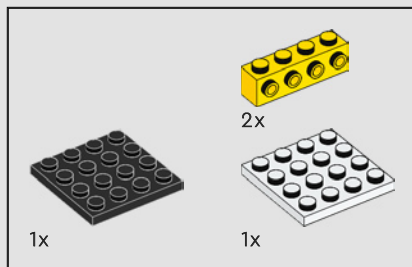

495

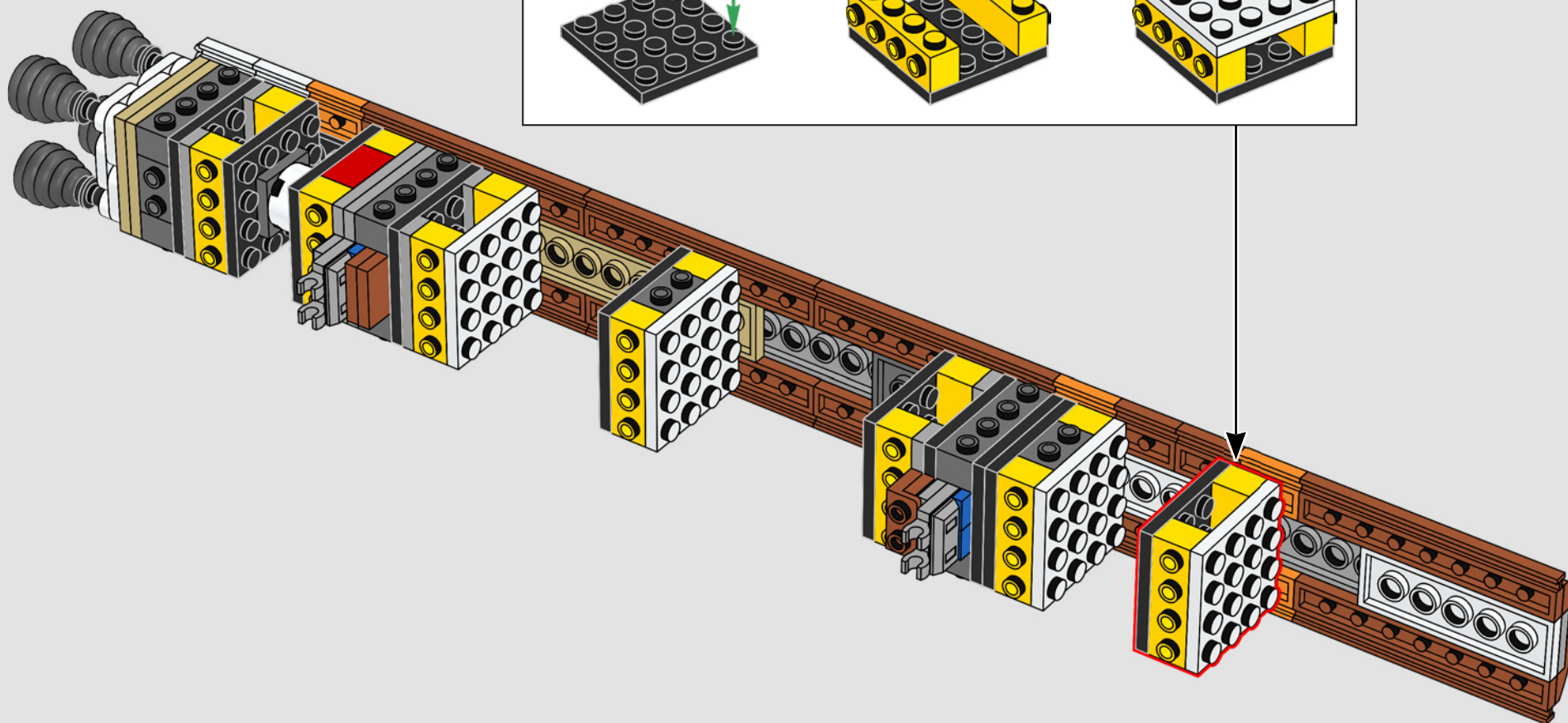
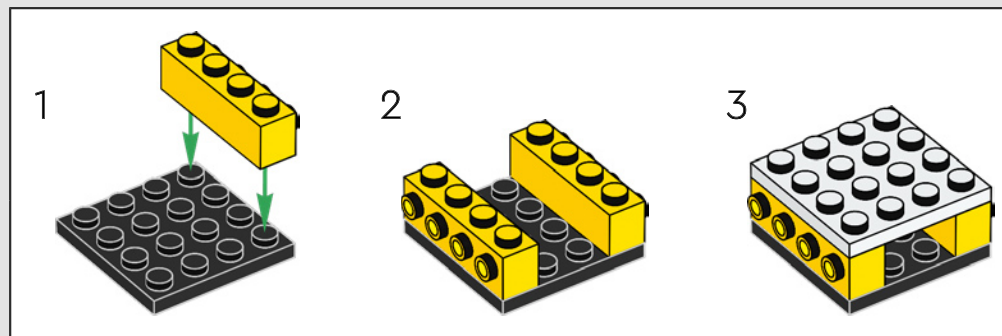

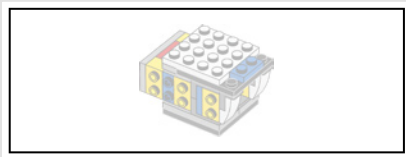

496

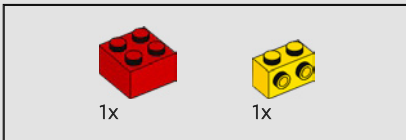
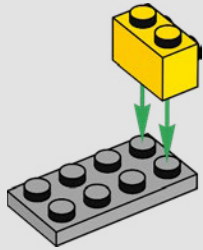

497

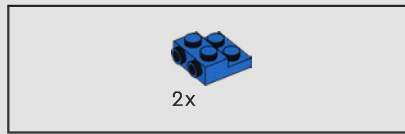
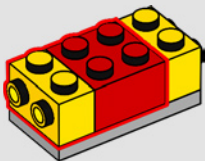

498

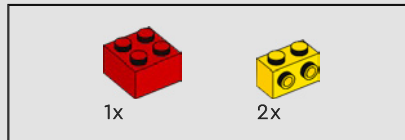
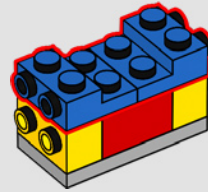

499

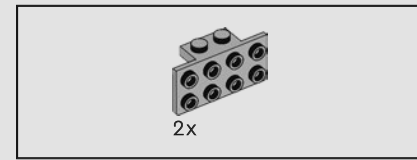
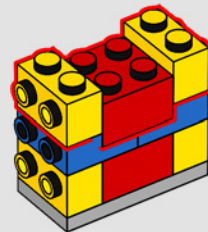

500

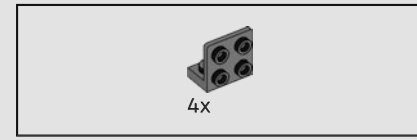
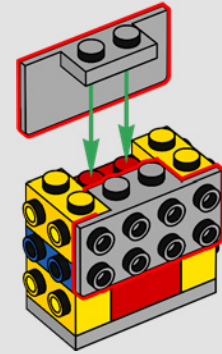

501

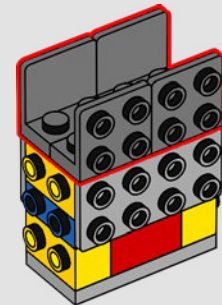

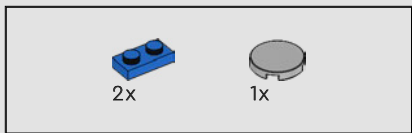

502

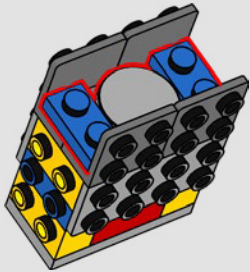

503

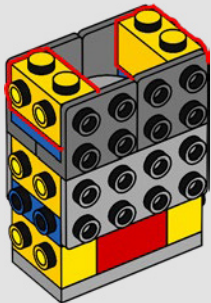

504

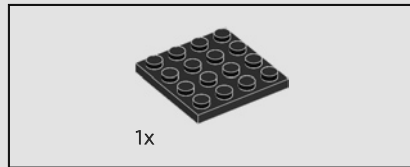
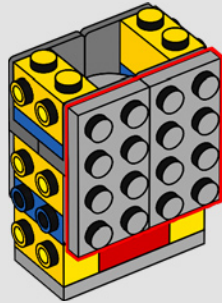

505

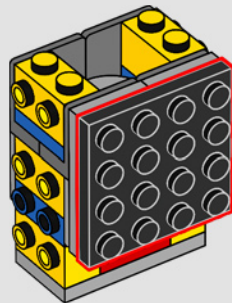

506

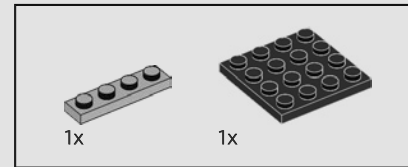
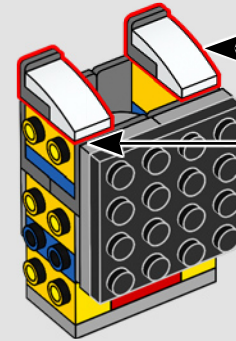
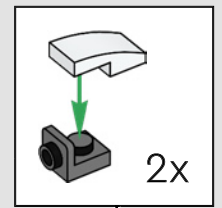

507

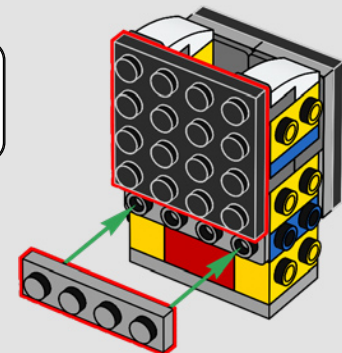
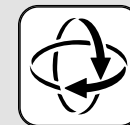

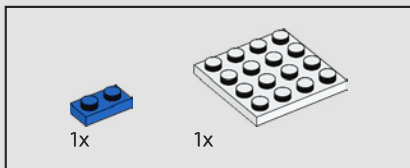

508

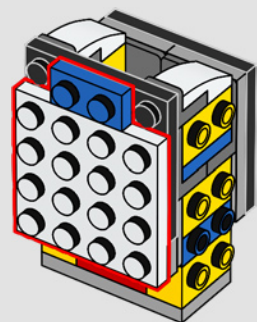

509

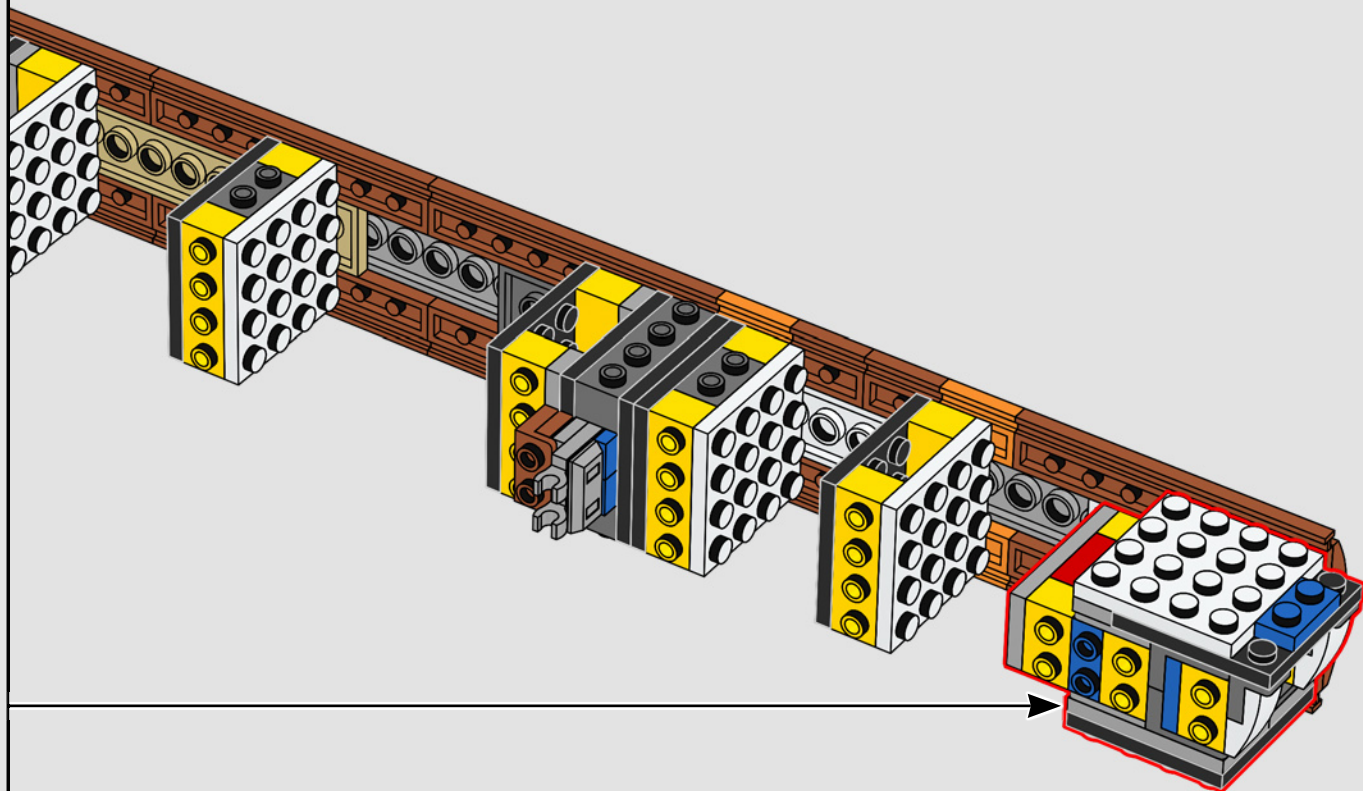

Die Hauptstufe wurde eigens für das SLS entwickelt.
Sie beherbergt Treibstofftanks, Bordelektronik und die
dazugehörige Ausrüstung. An den vier RS-25-Triebwerken
befinden sich Befestigungspunkte für die Booster.



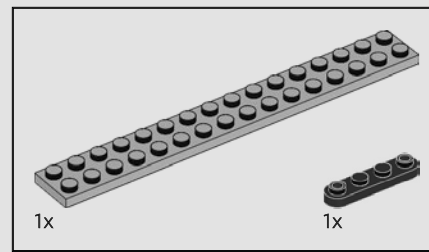

510

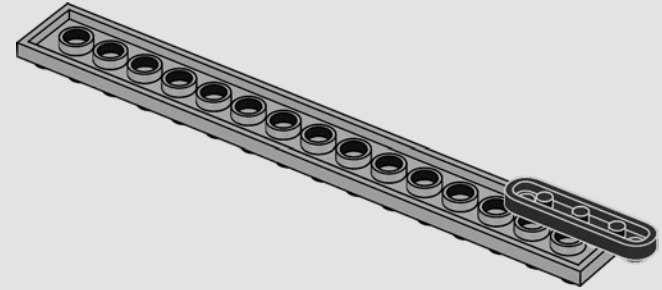

511

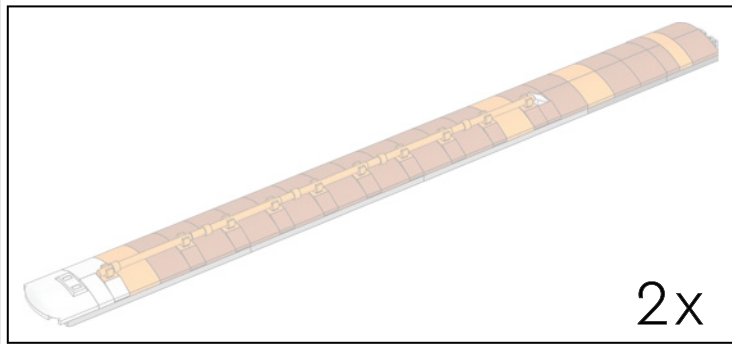
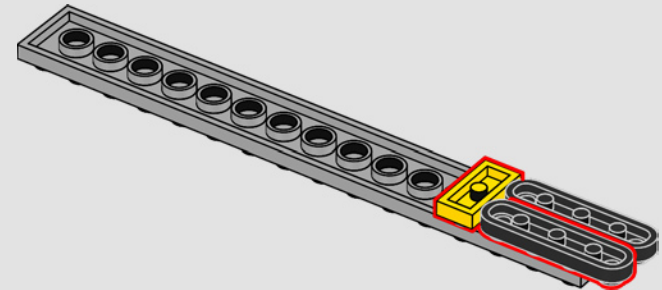

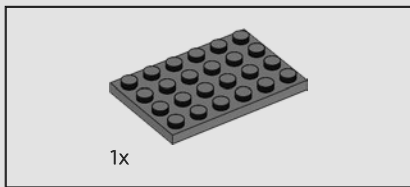

512

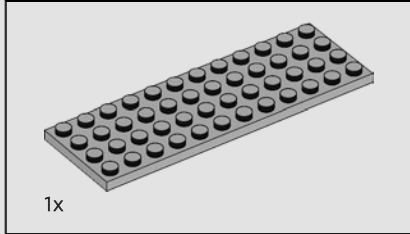
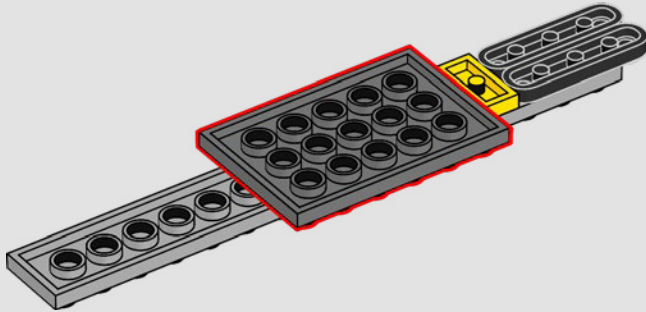

513

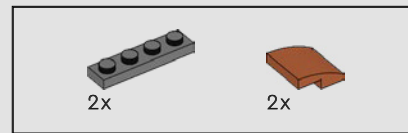
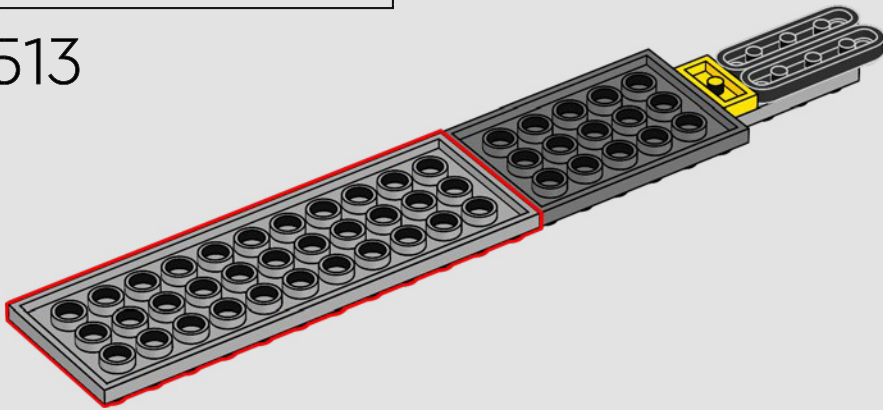

514

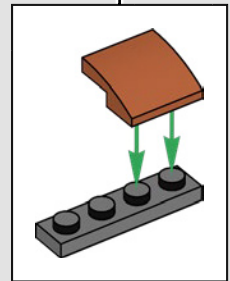
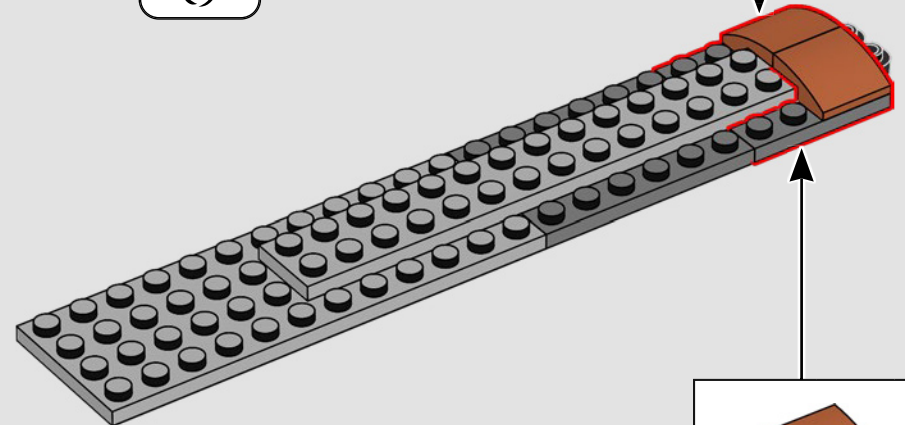
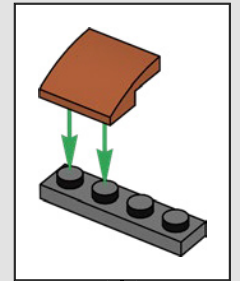
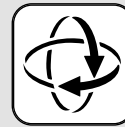

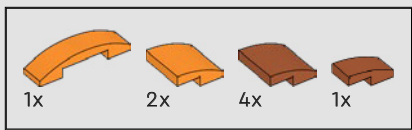

515

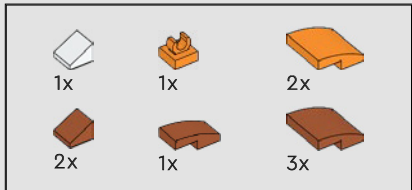
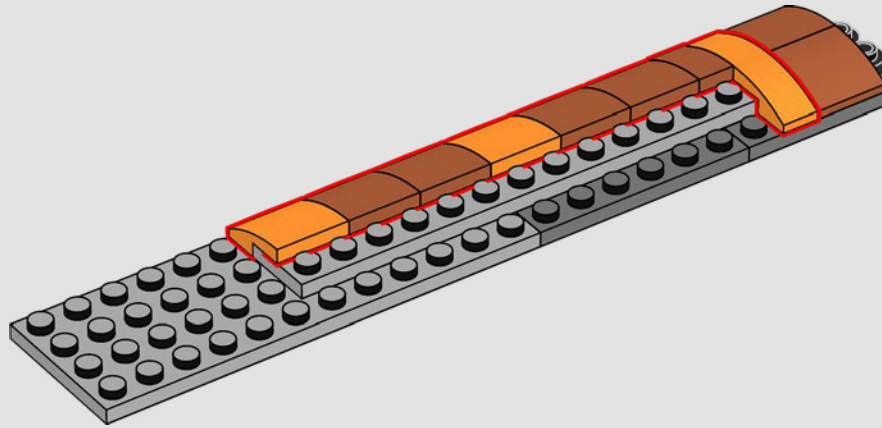

516

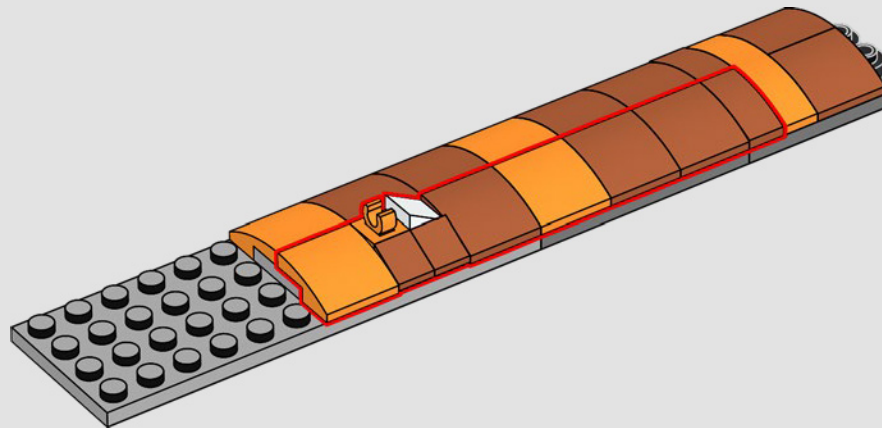

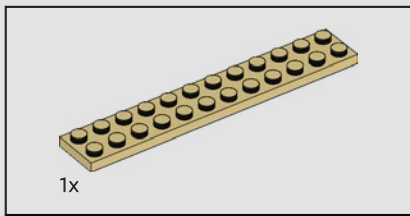

517

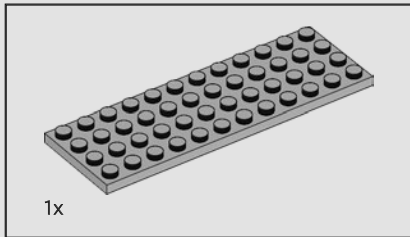
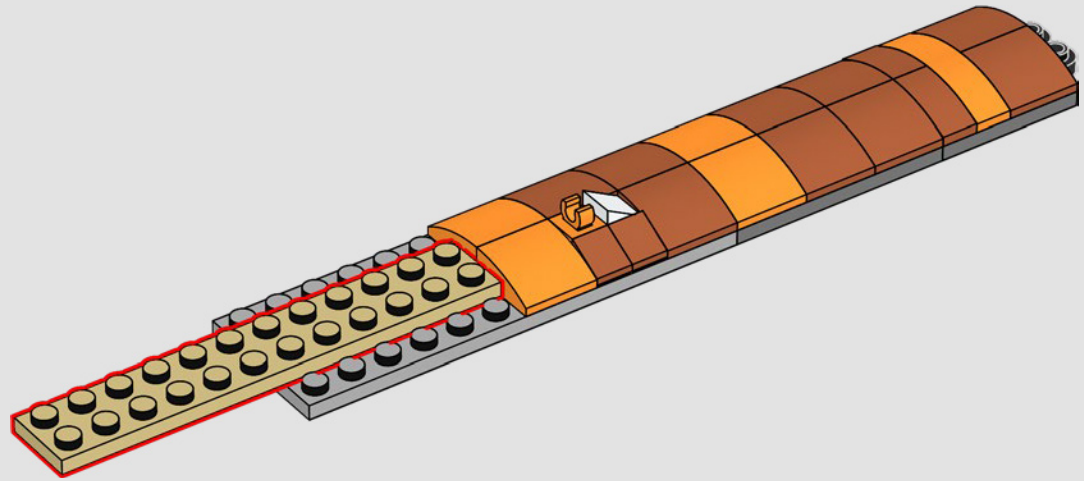

518

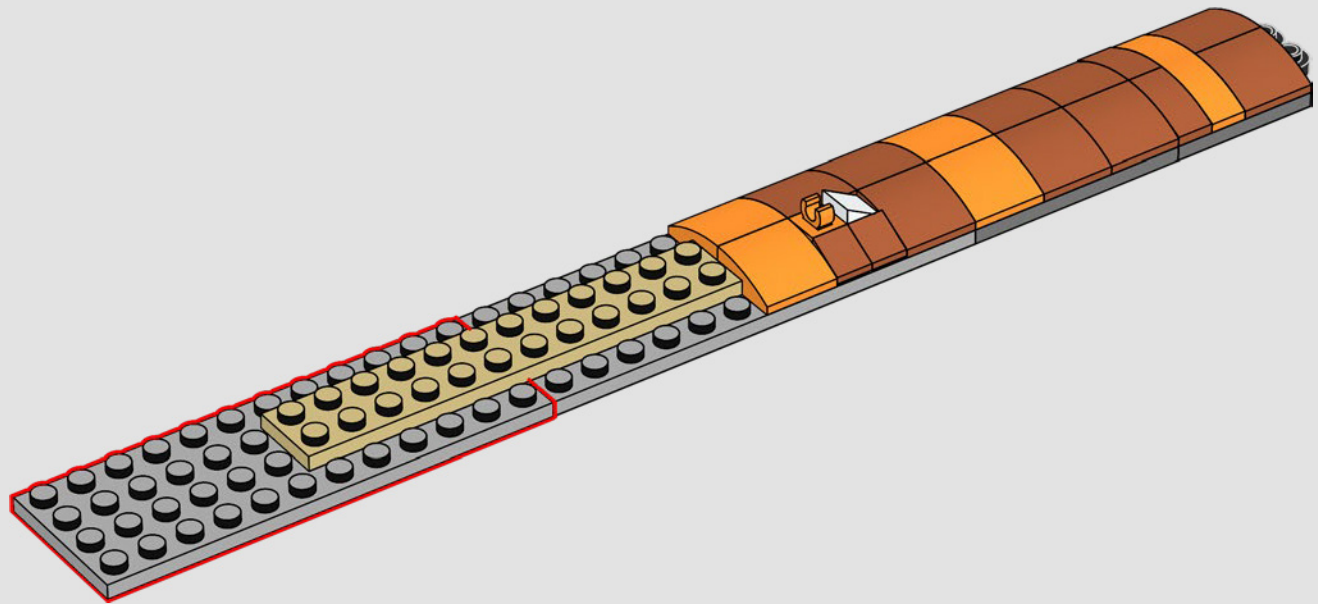

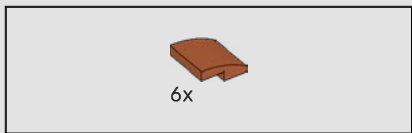

519

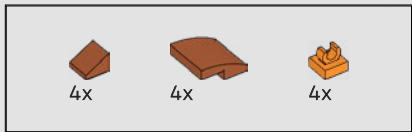
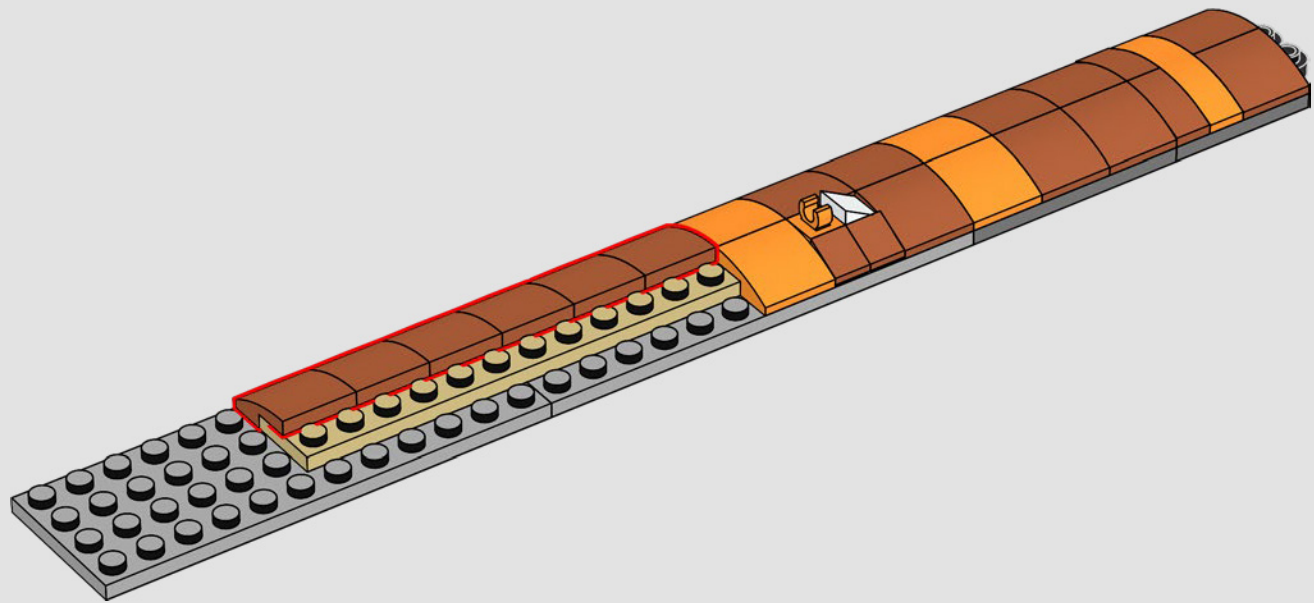

520

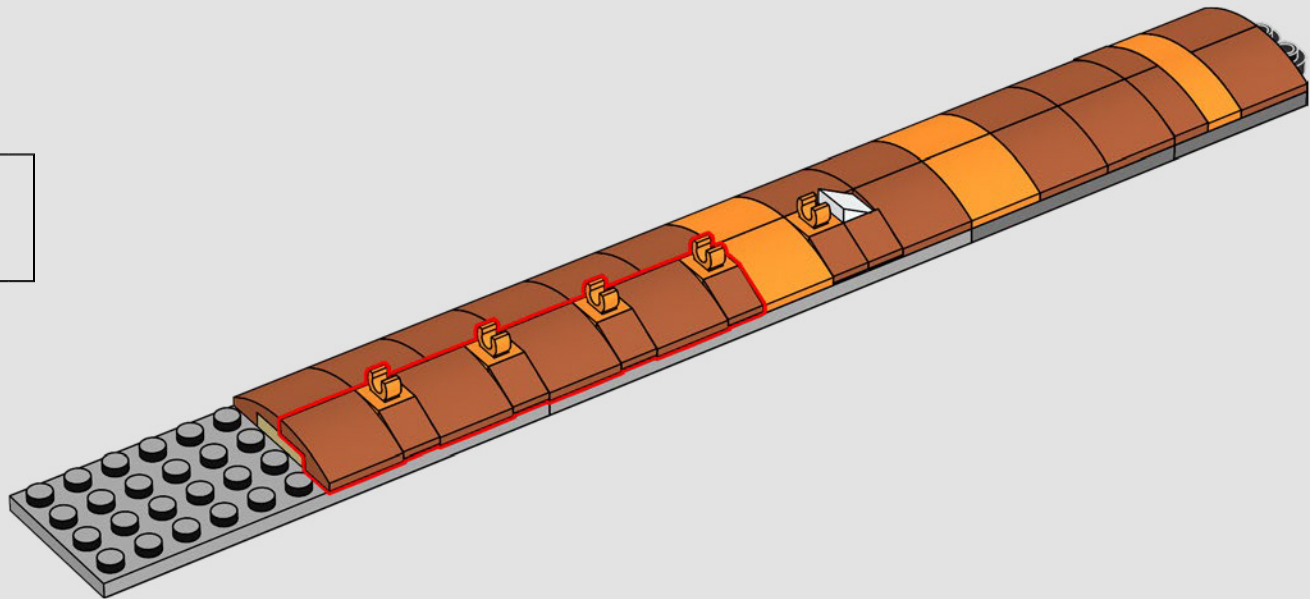

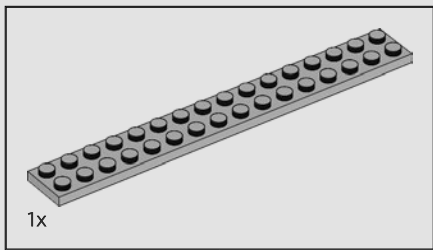

521

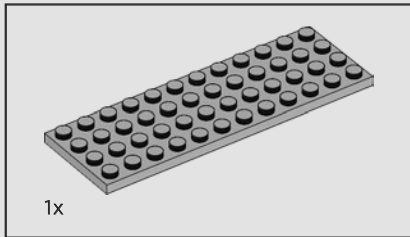
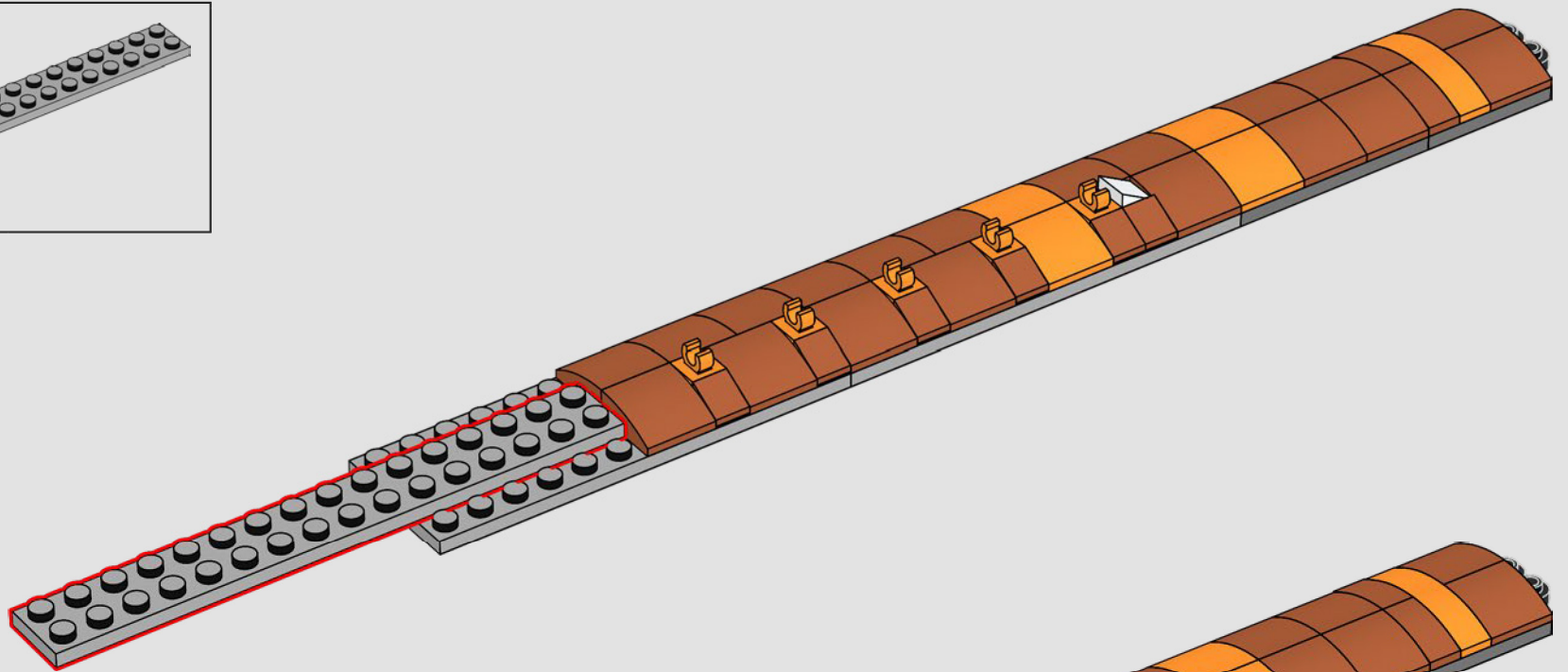

522

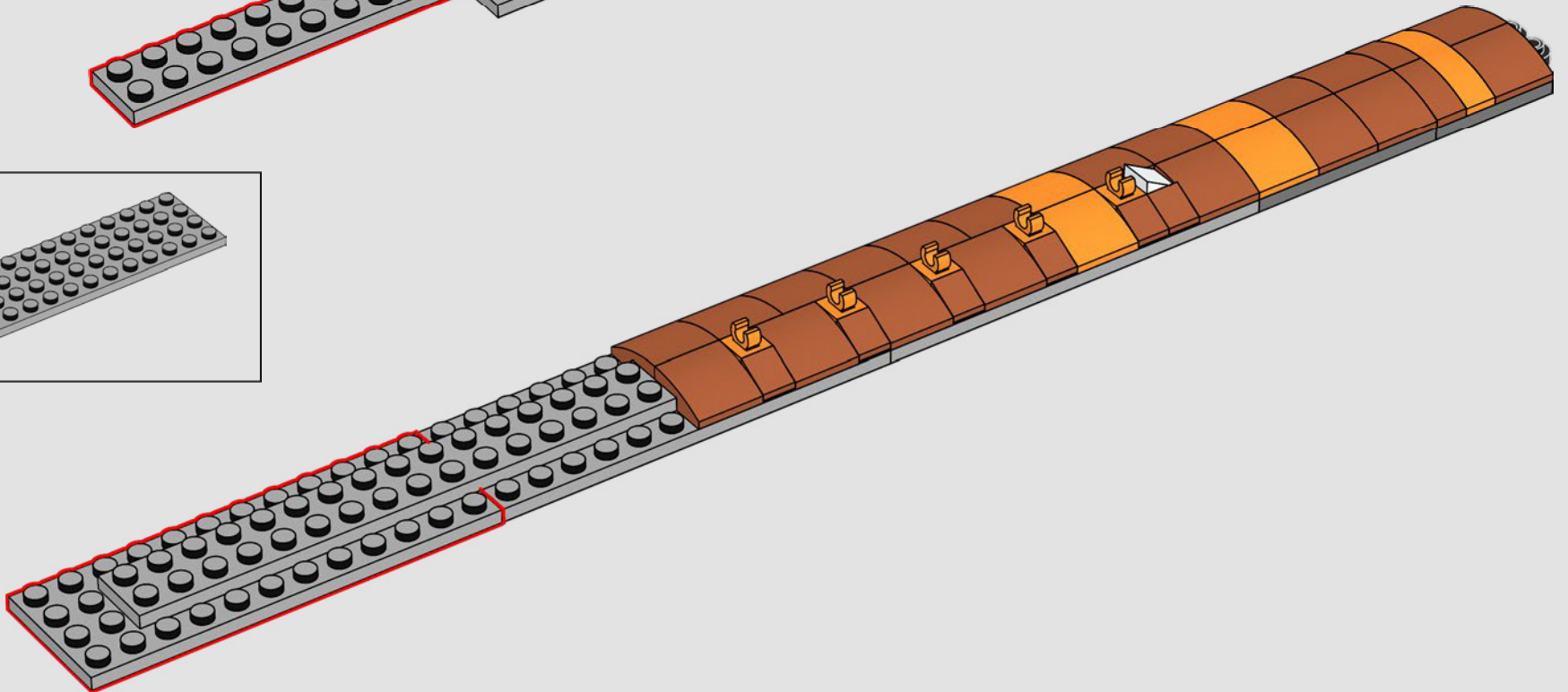

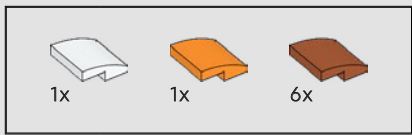

523

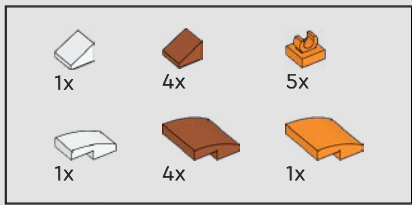
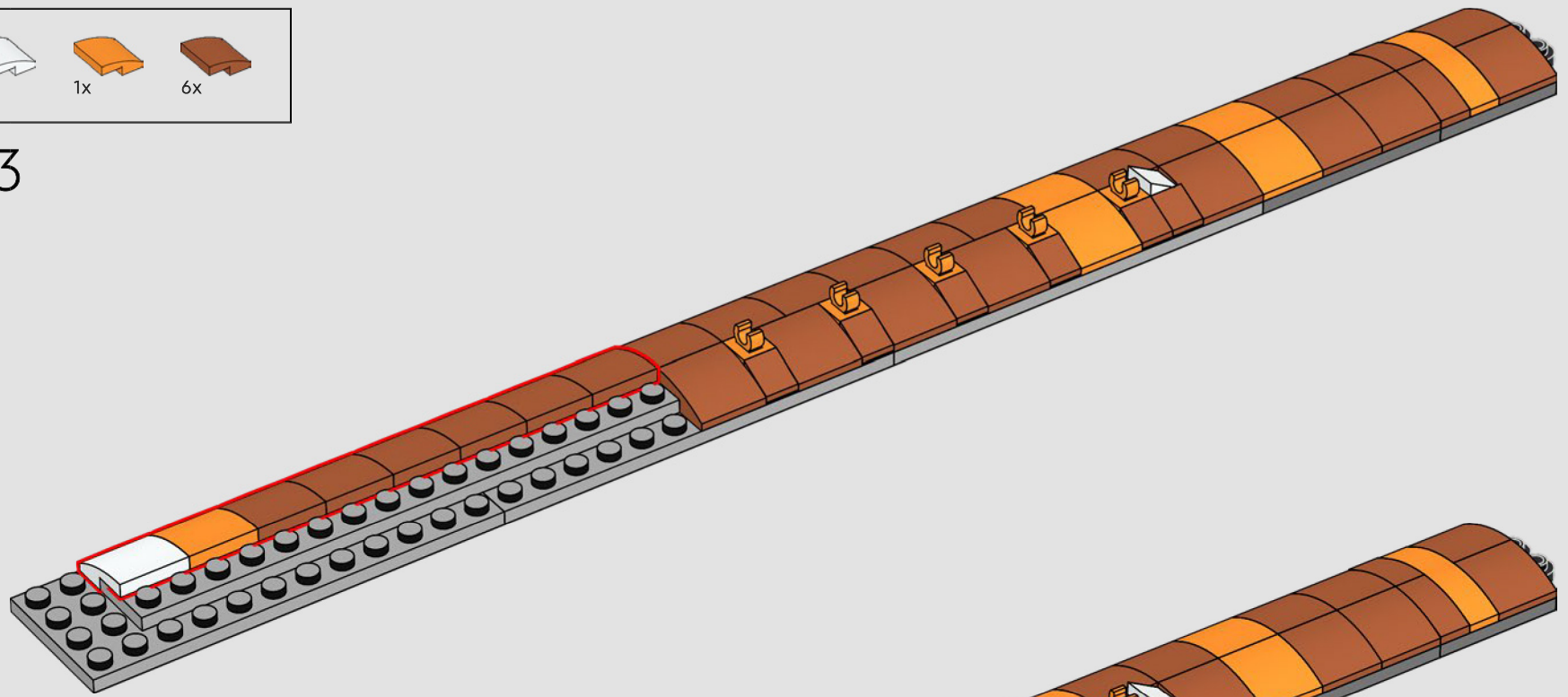

524

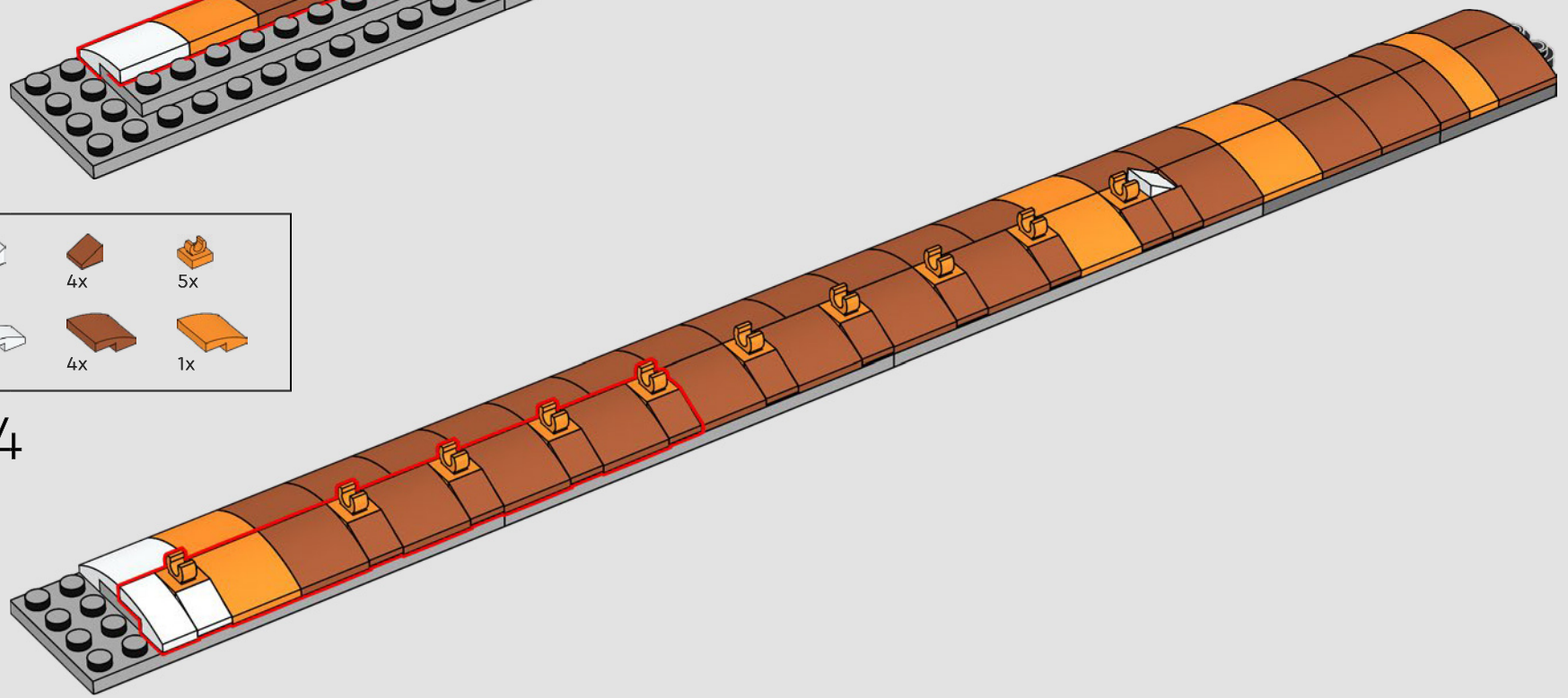

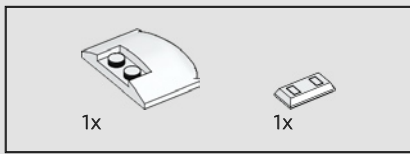

525

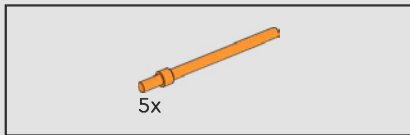
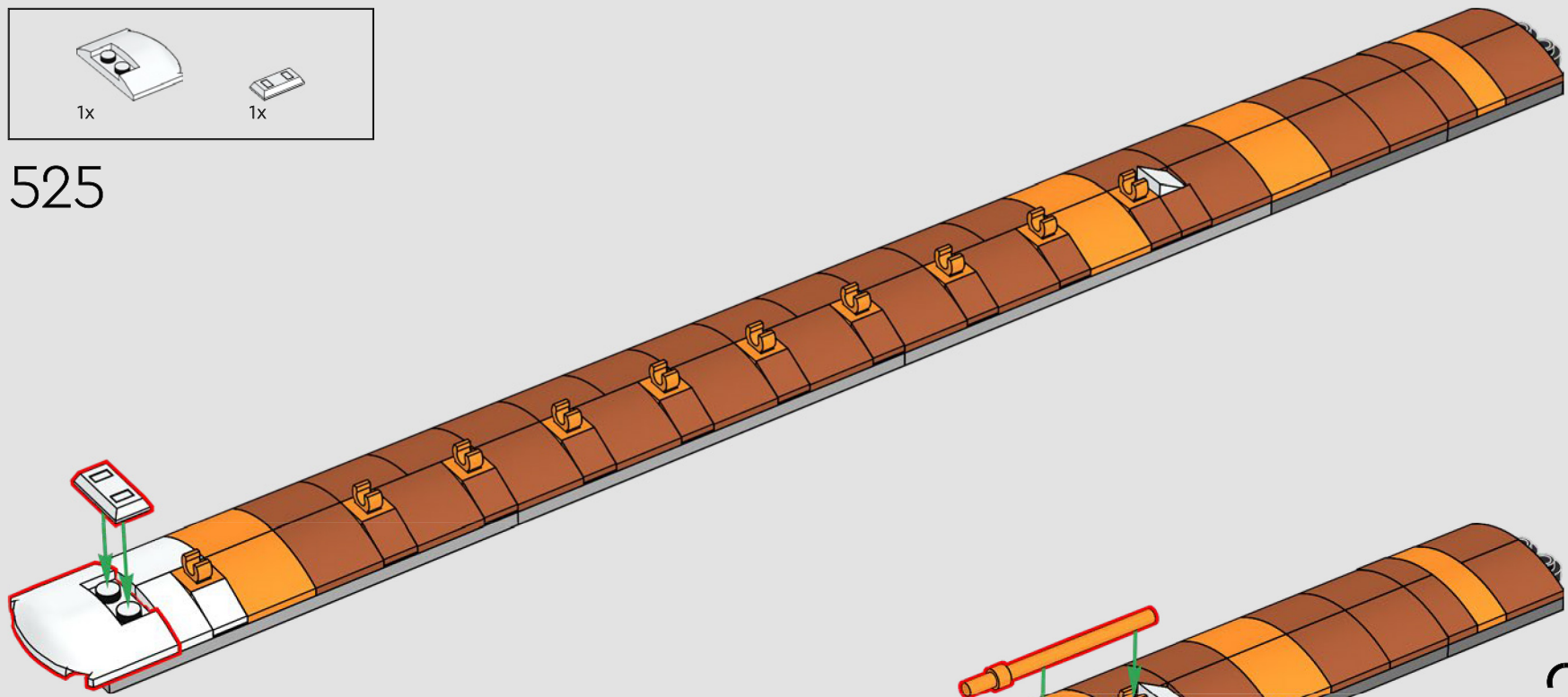

526

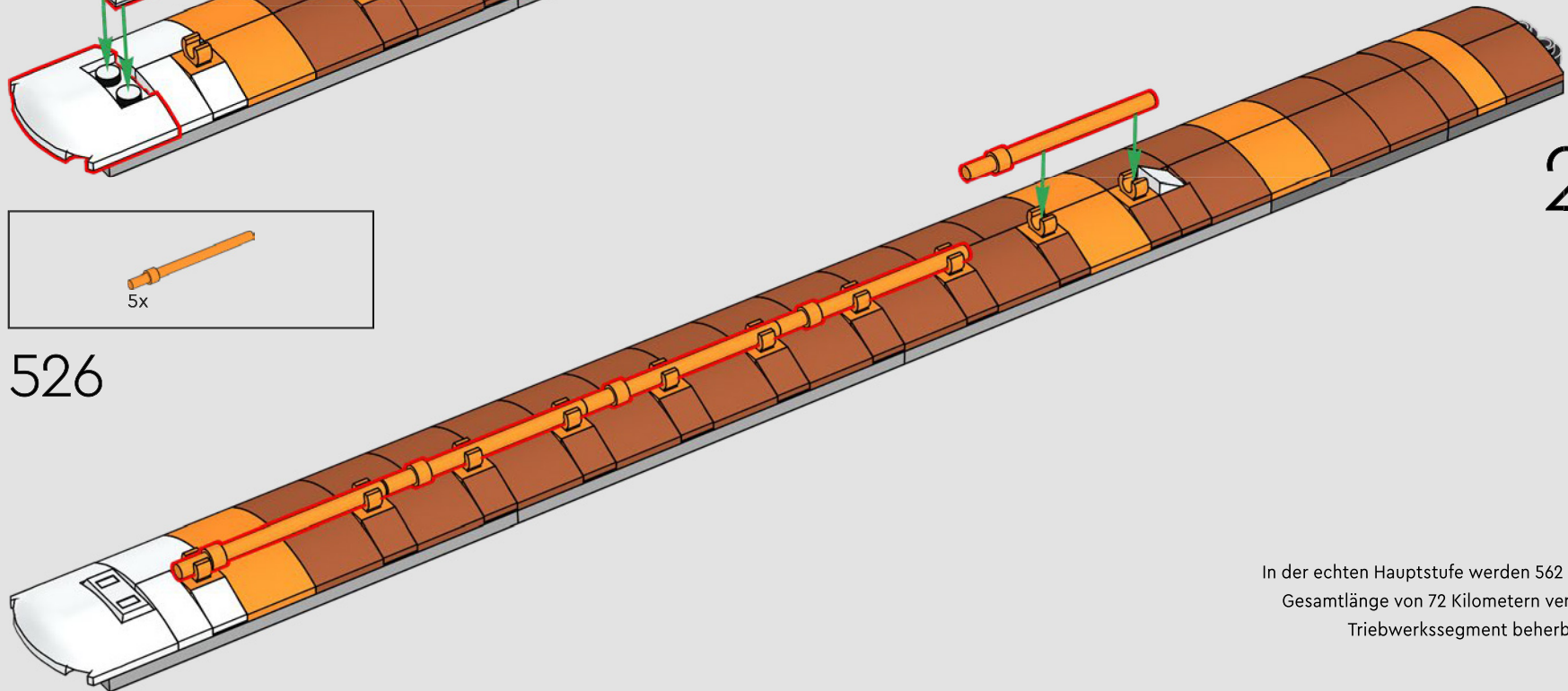

In der echten Hauptstufe werden 562 Kabel mit einer Gesamtlänge von 72 Kilometern verlegt. Allein das Triebwerkssegment beherbergt 231 Kabel.

527

Der orange Isolierschaum an der ersten Stufe trägt zur Kühlung des Treibstoffs bei. Der Schaum reagiert auf Sonnenlicht und wird dann an den dünnsten Stellen heller. Das erklärt die hellorangenen Elemente an diesem ansonsten dunkelorange Modell.

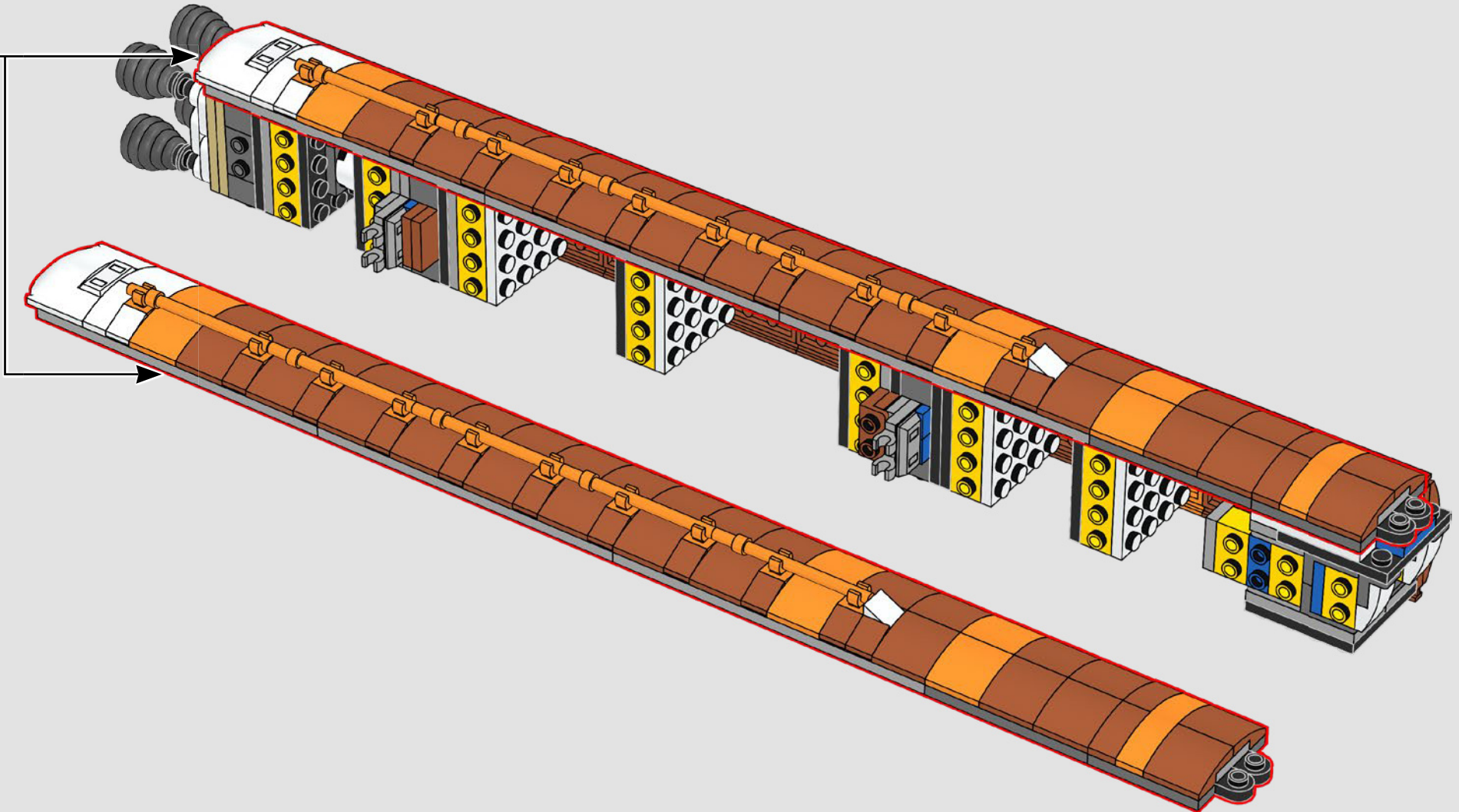

528

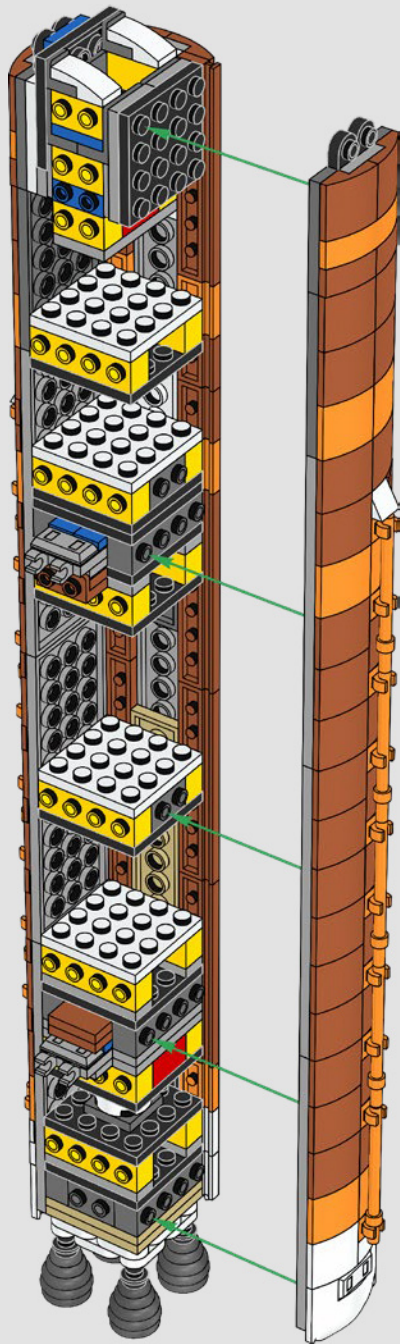

529

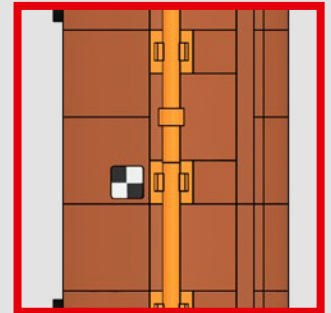
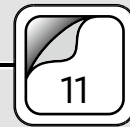
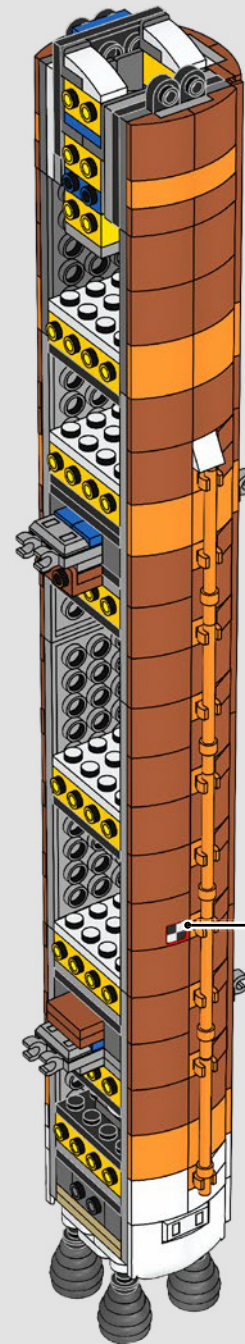

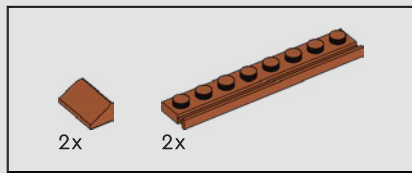

533

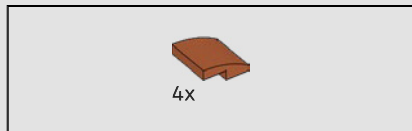
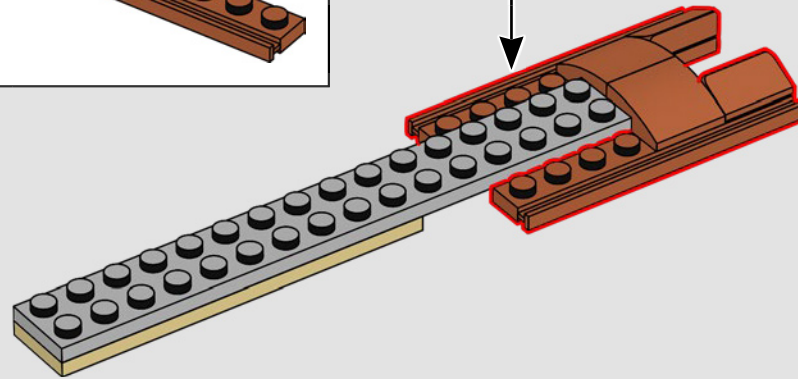
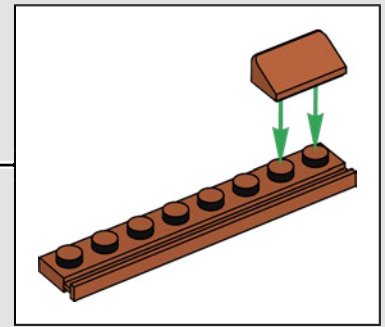
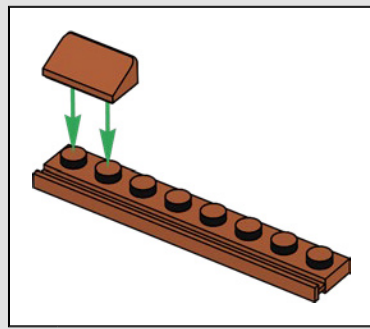

534

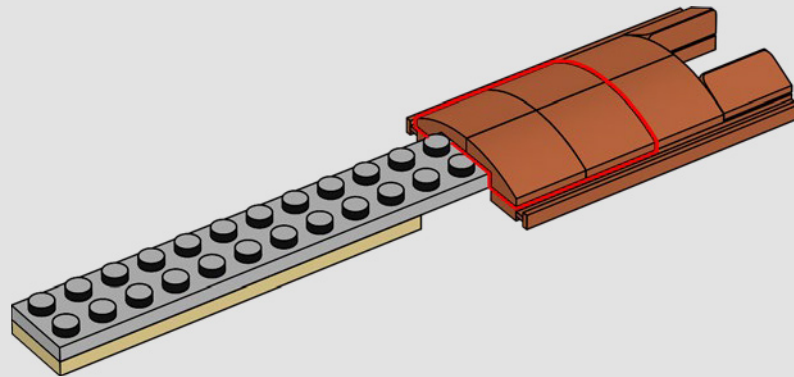

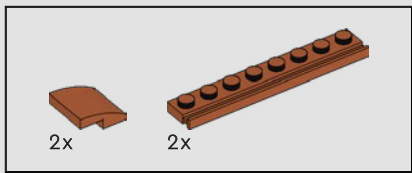

535

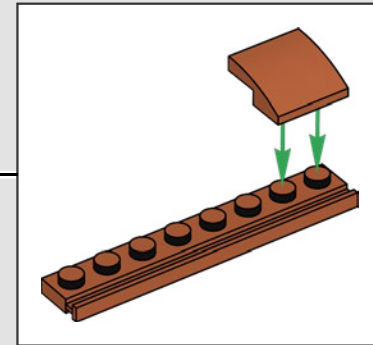
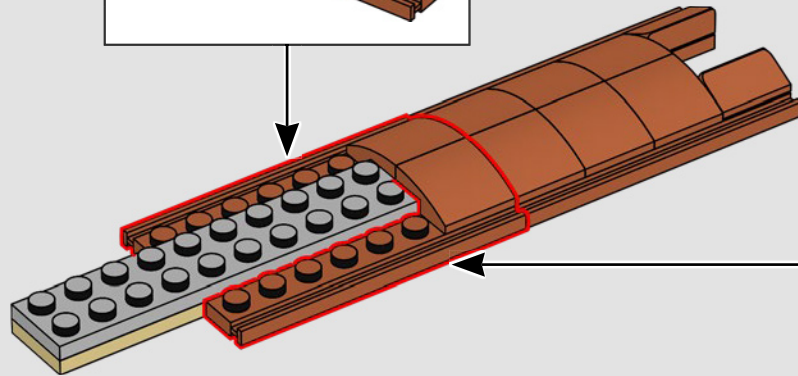
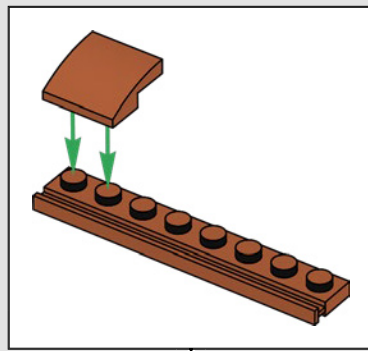

536

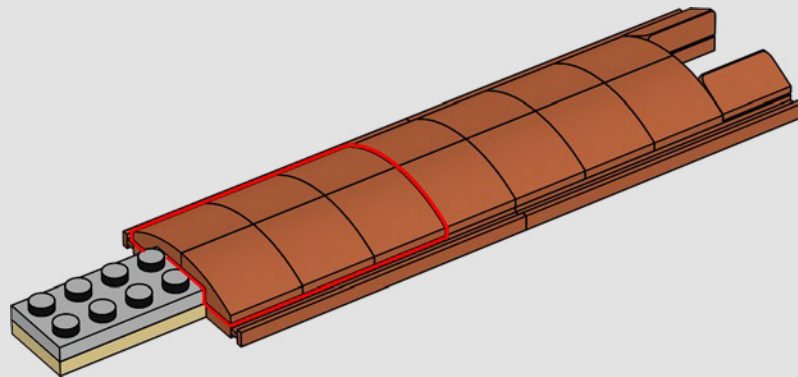

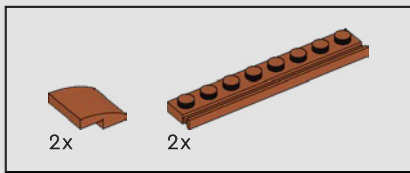

537

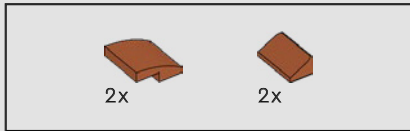
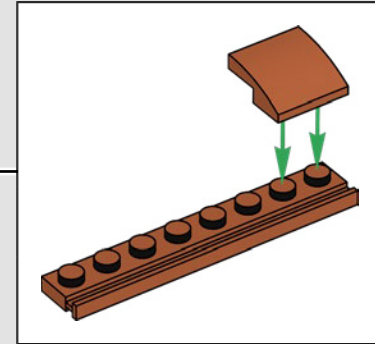
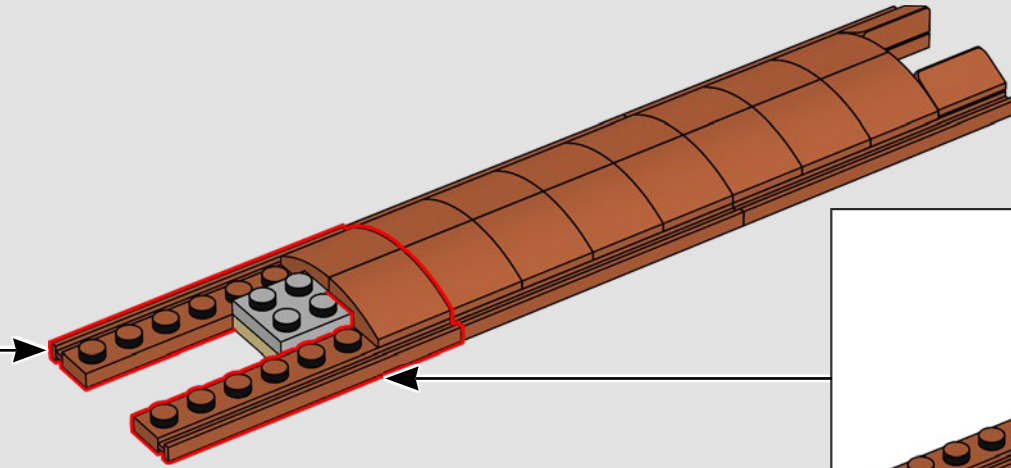
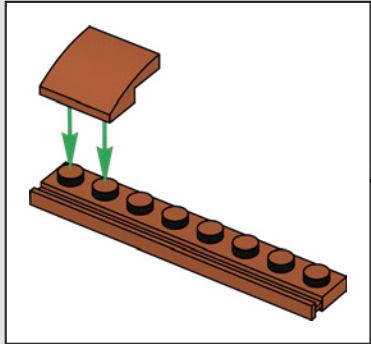

538

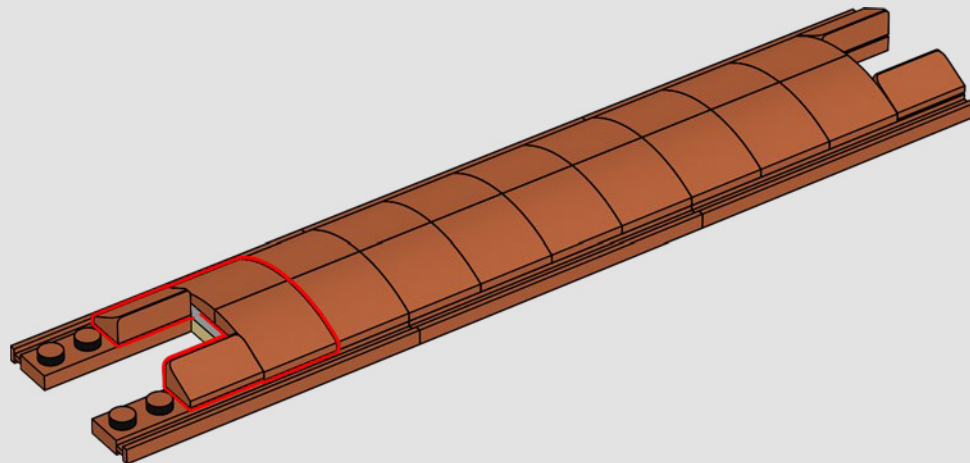

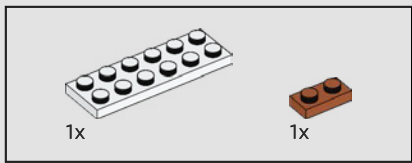

539

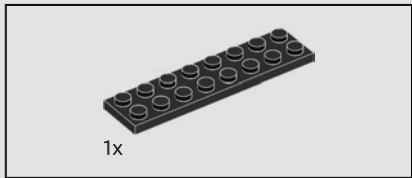
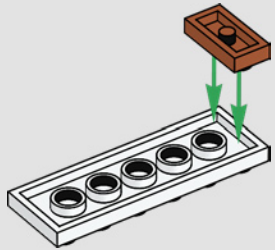

540

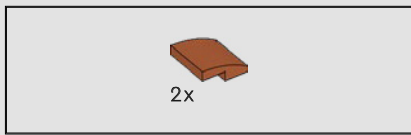
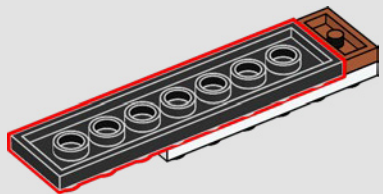

541

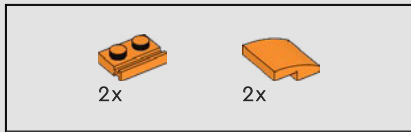
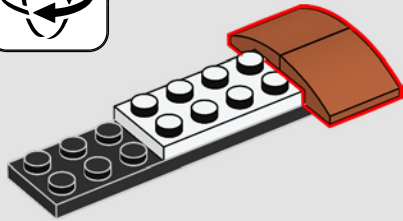
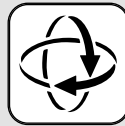

542

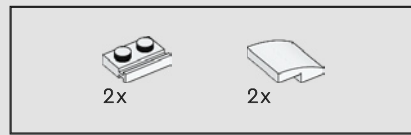
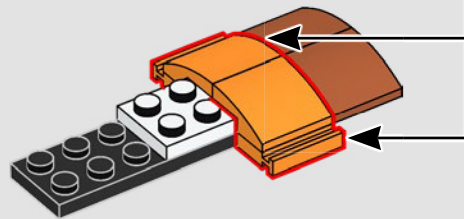
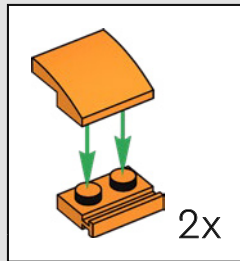

543

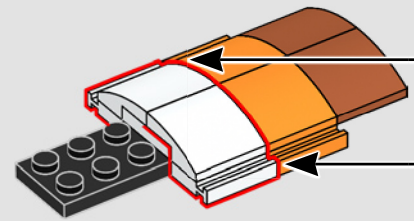
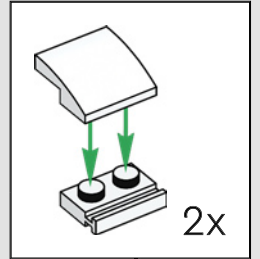

544

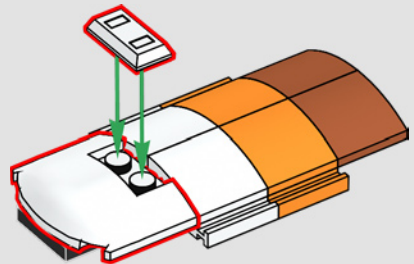

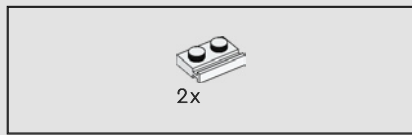

545

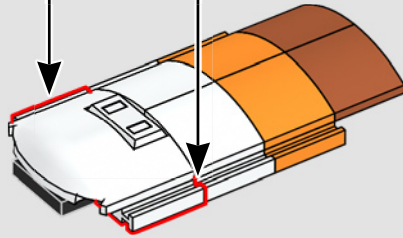
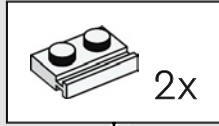

546

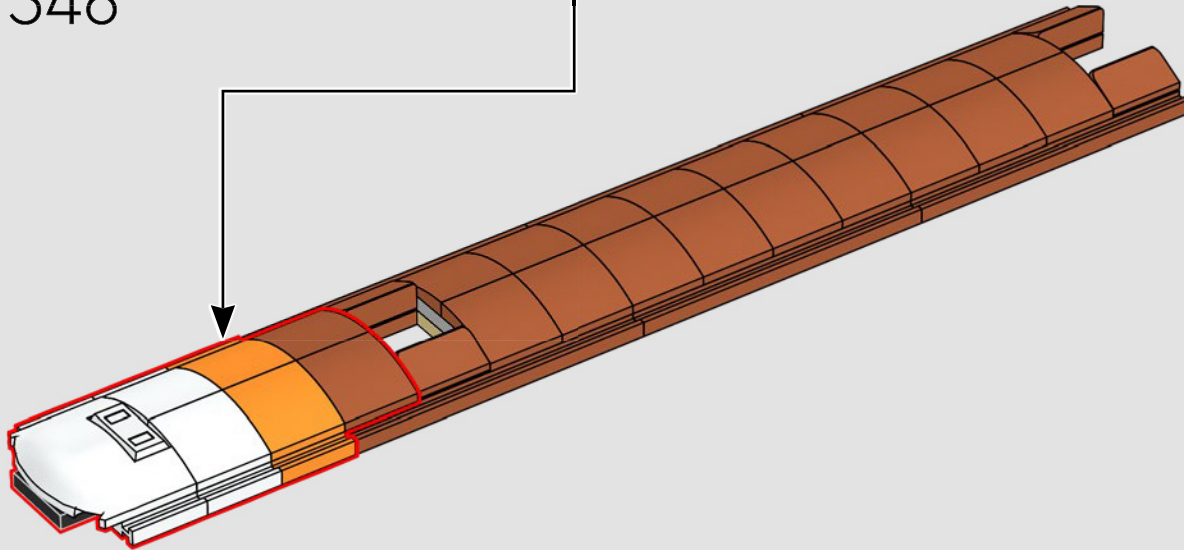

547

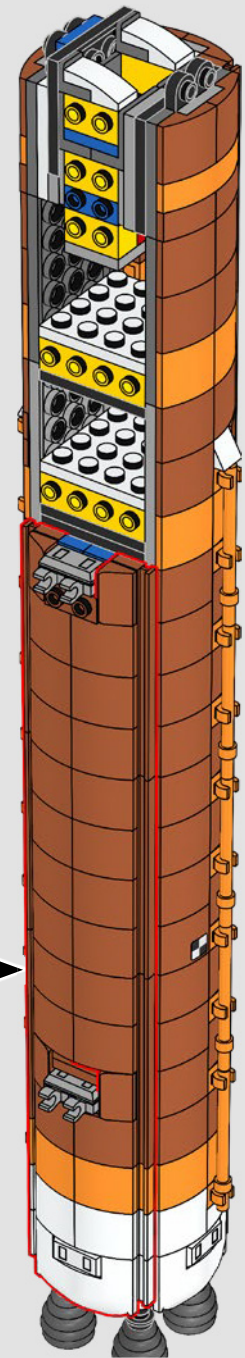

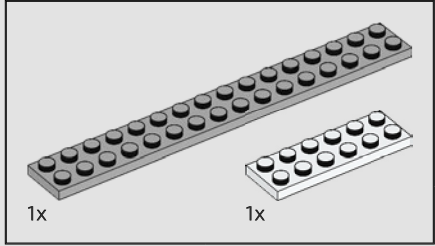
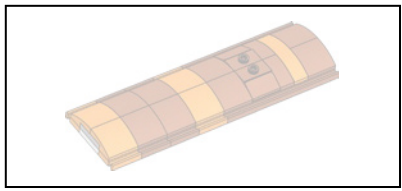

548

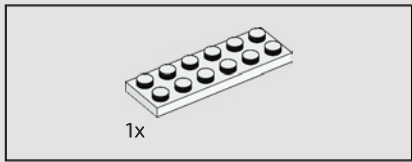
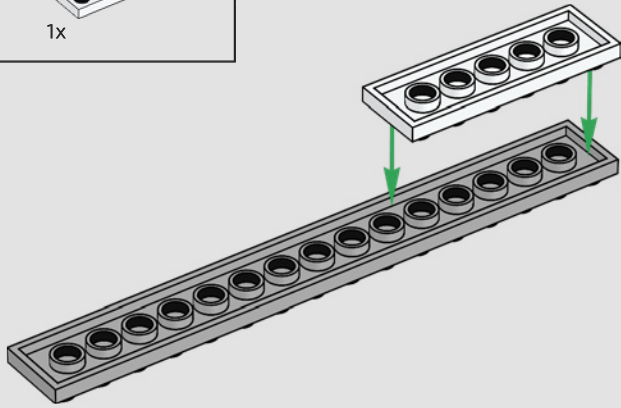

549

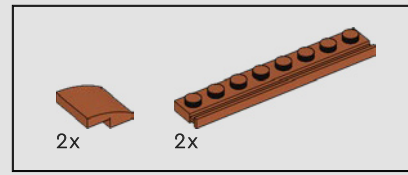
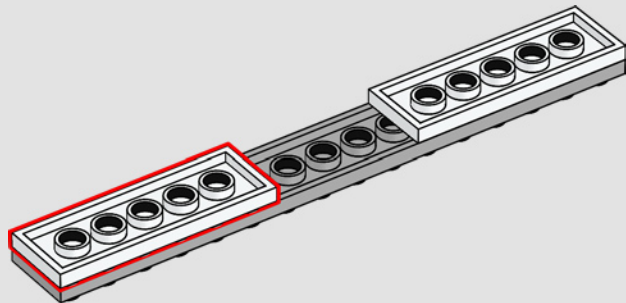

550

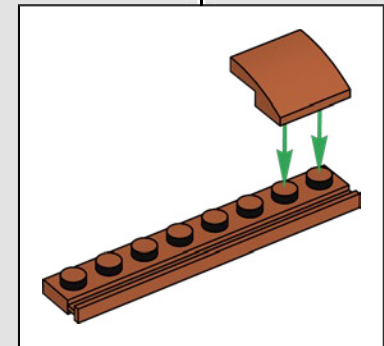
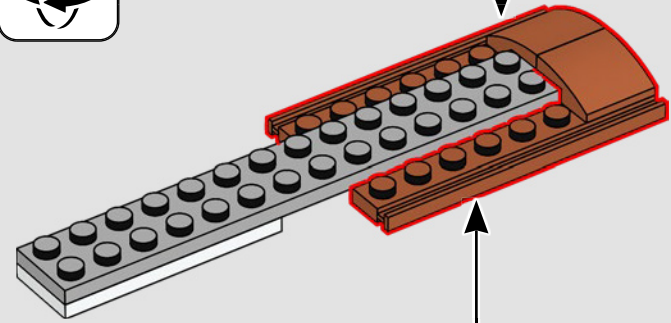
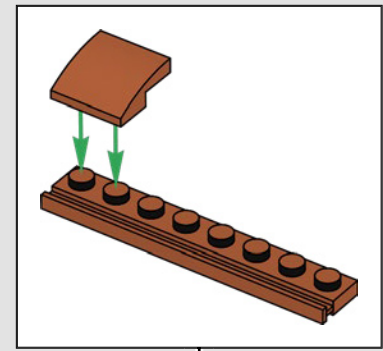
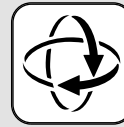

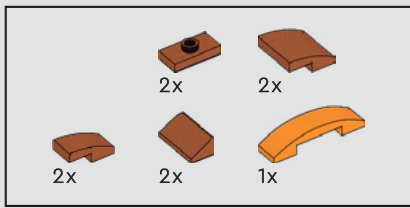

551

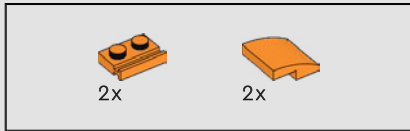
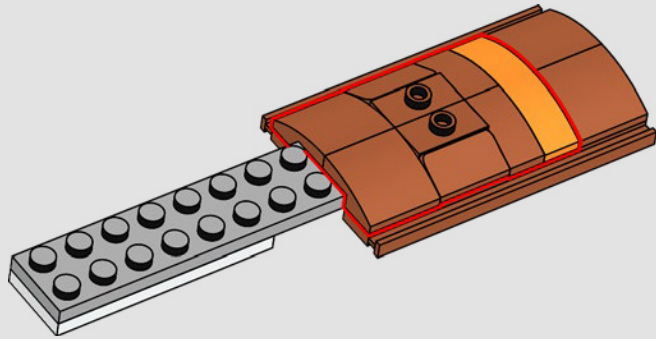

552

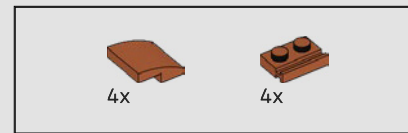
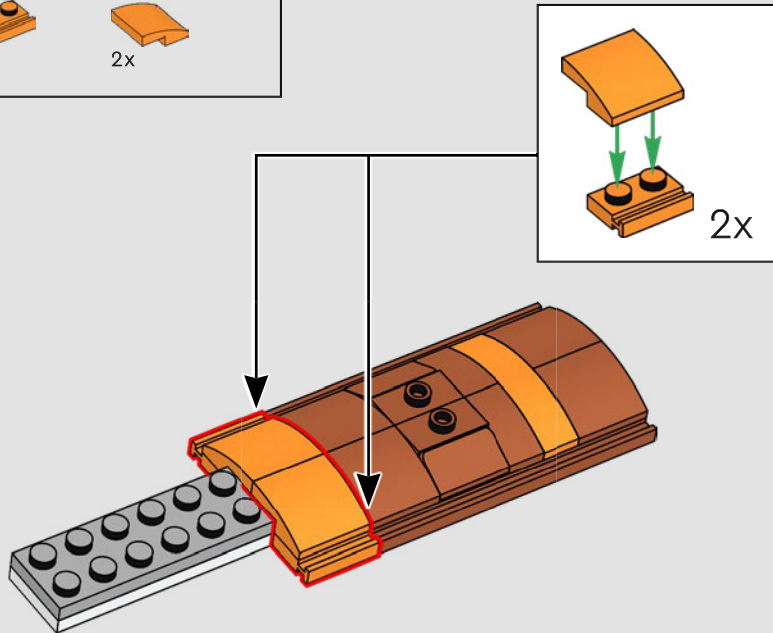

553

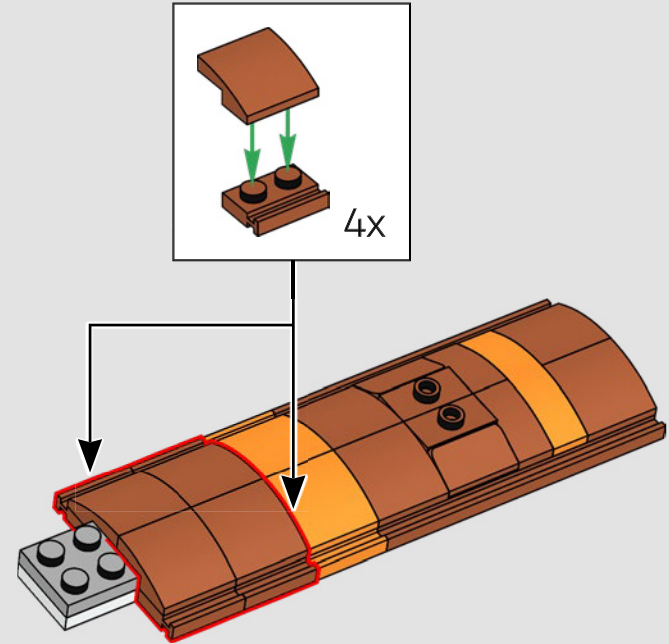

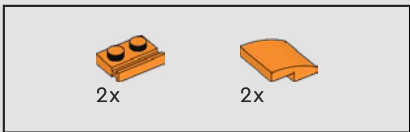

554

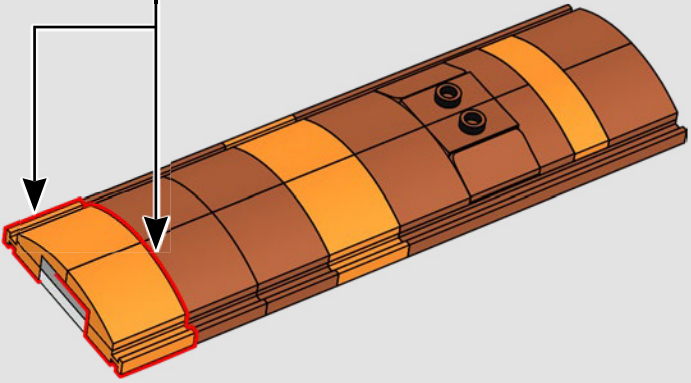
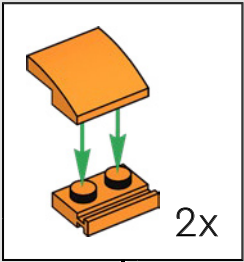

555

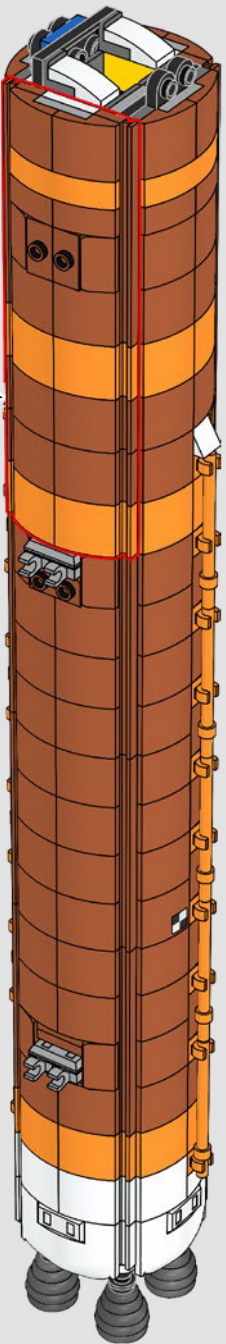

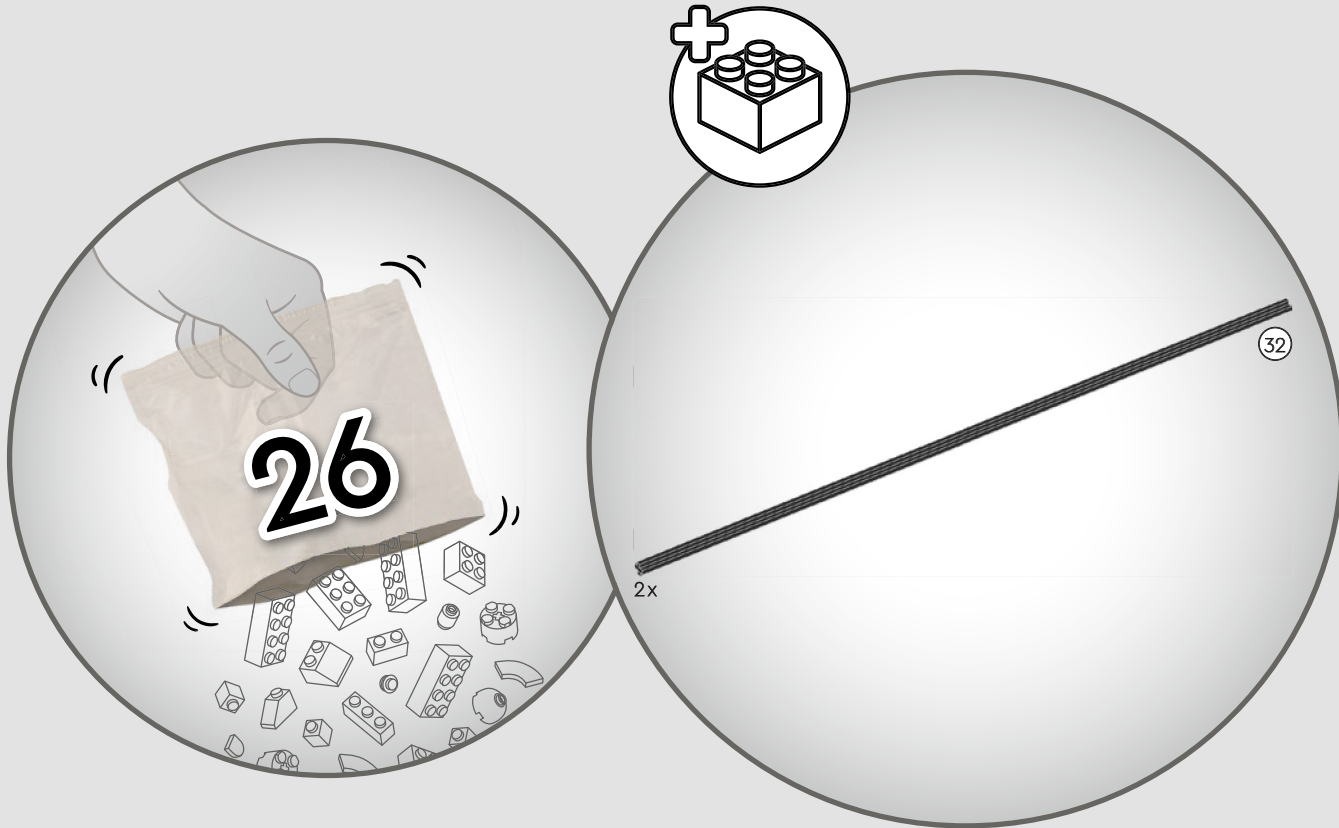

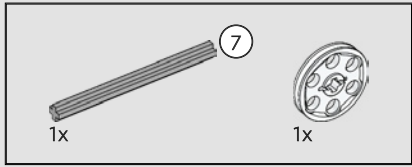
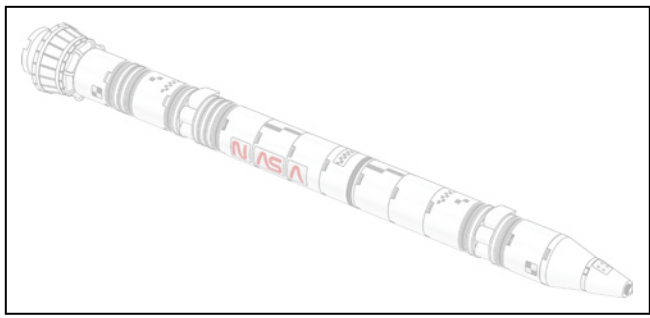

556

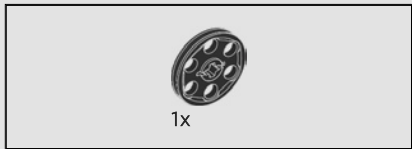
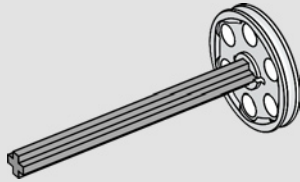

557

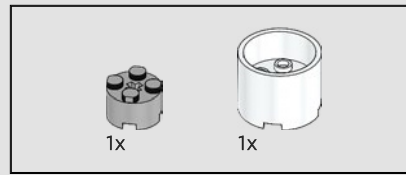
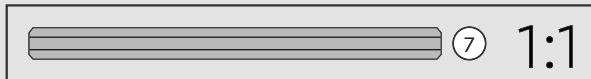
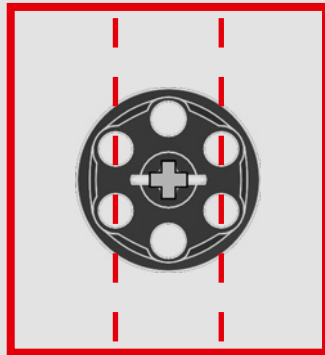
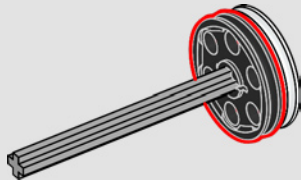

558

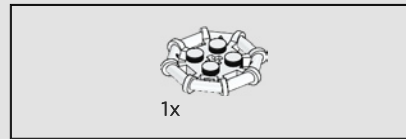
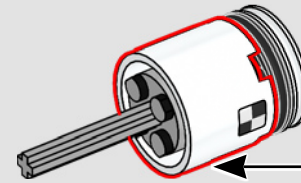
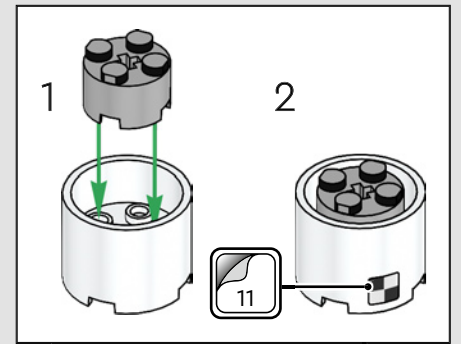

559

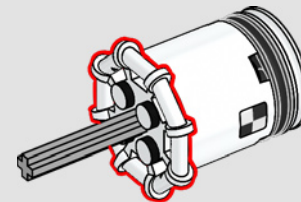

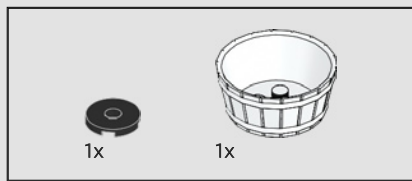

560

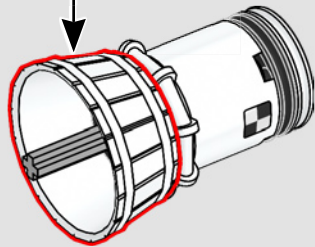
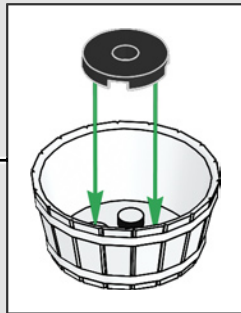

562

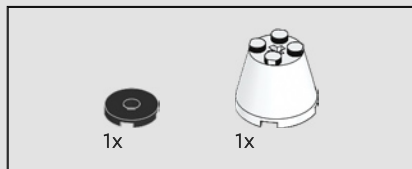
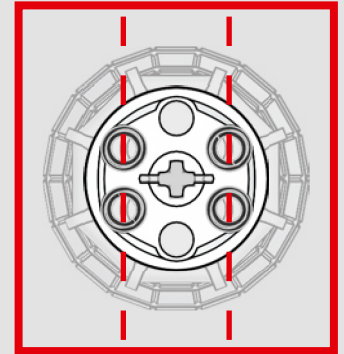
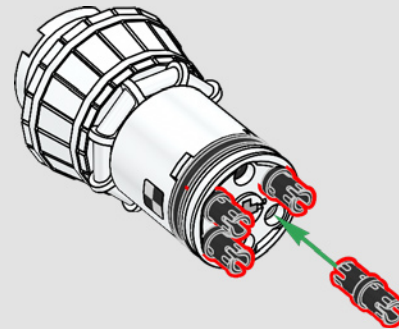
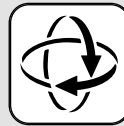

561

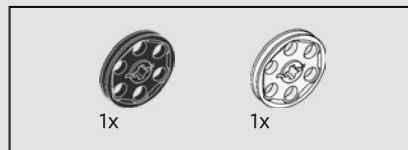
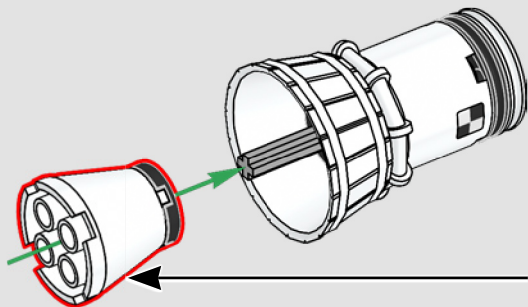
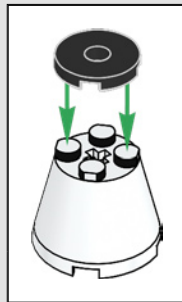

563

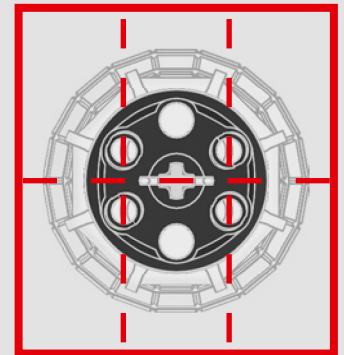
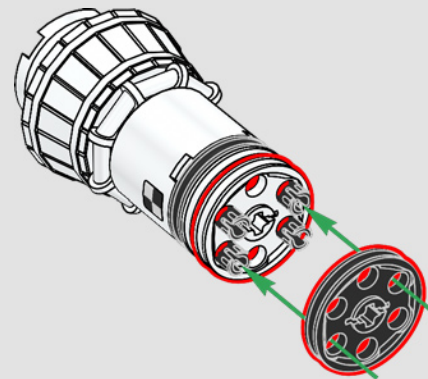

564

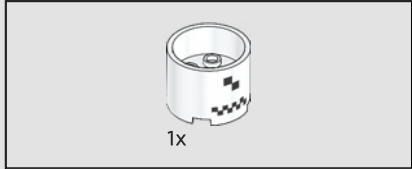
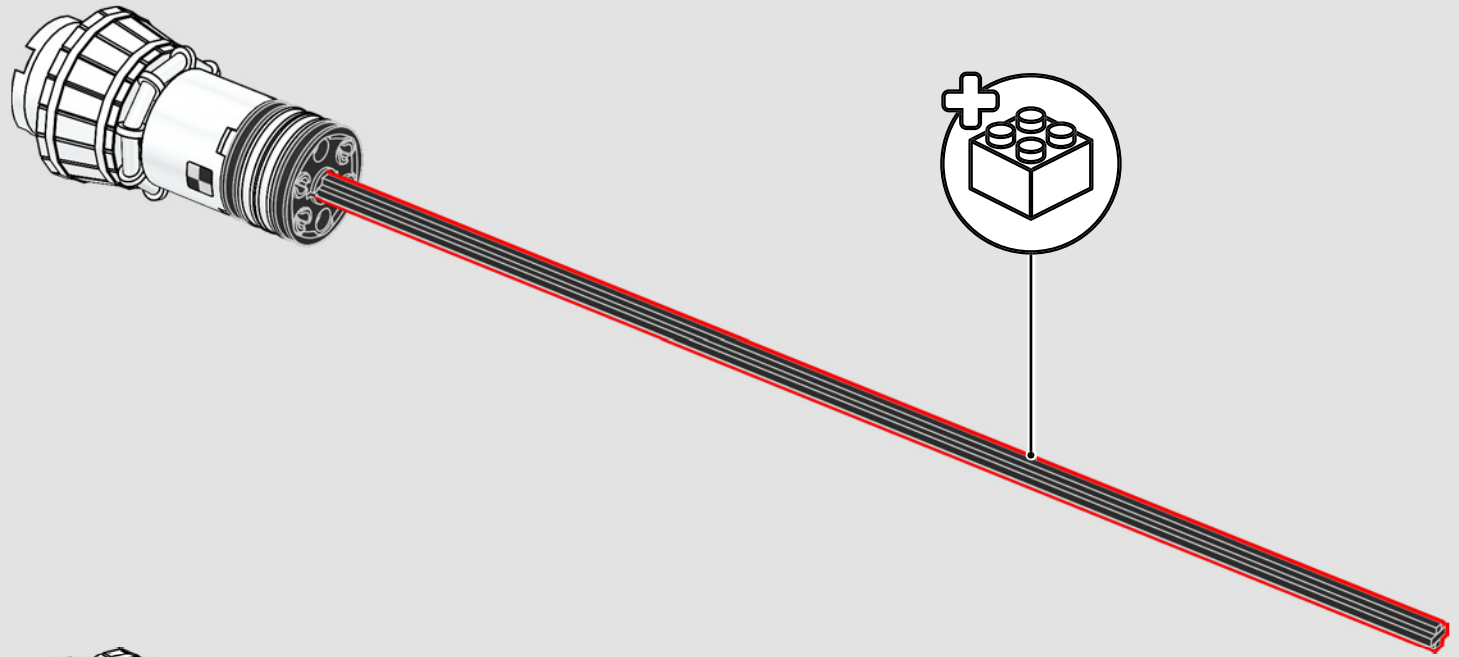

565

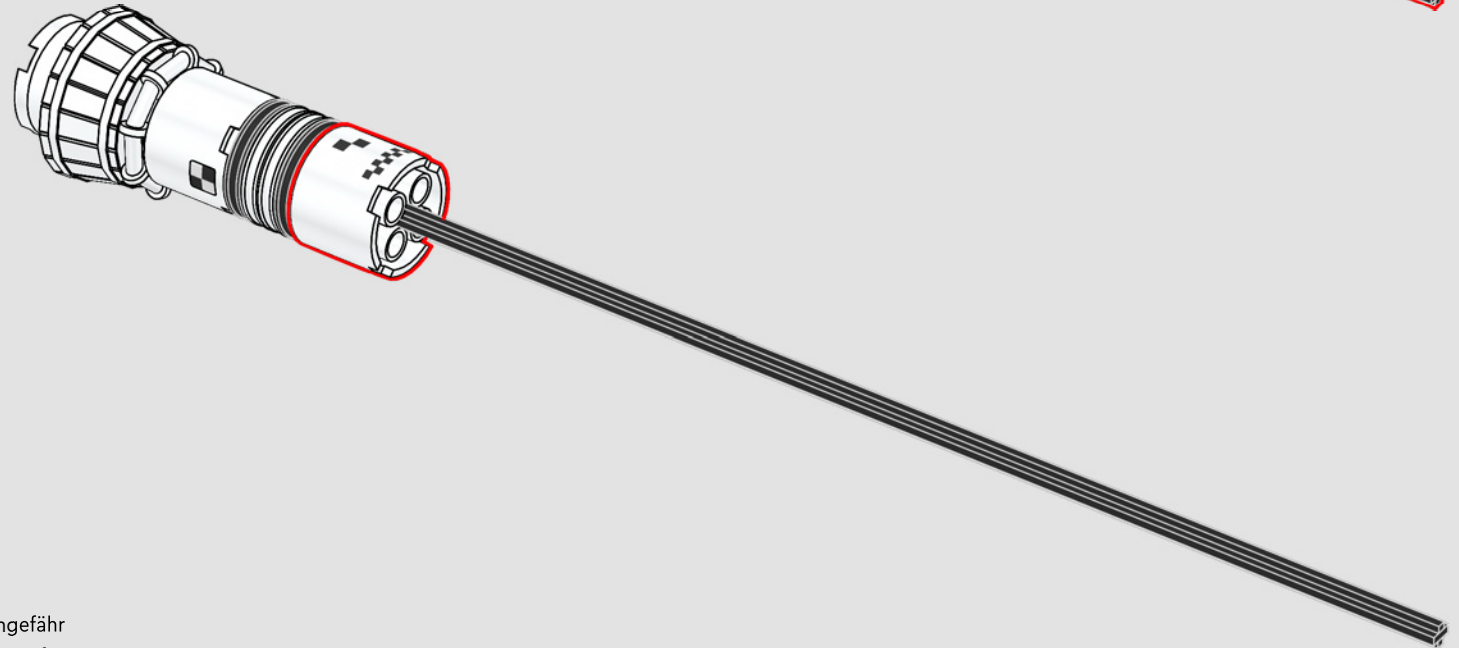

Nach dem Start des SLS brennen die Booster ungefähr zwei Minuten und lösen sich dann von der Hauptstufe.

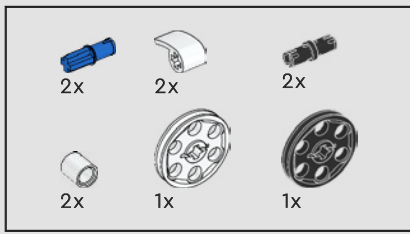

566

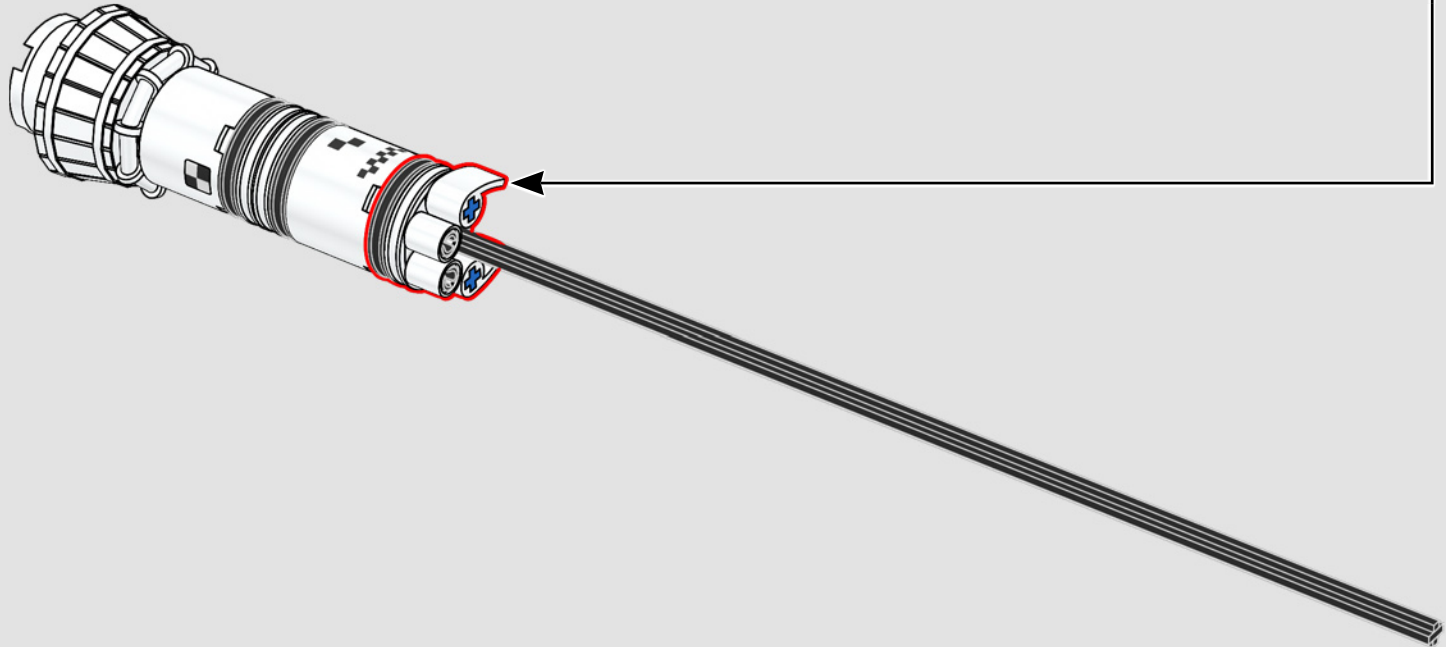
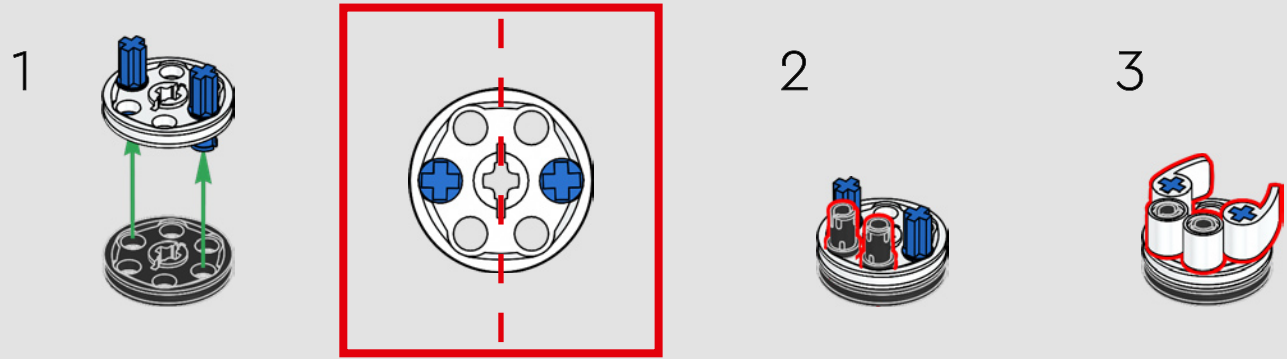



1x

567

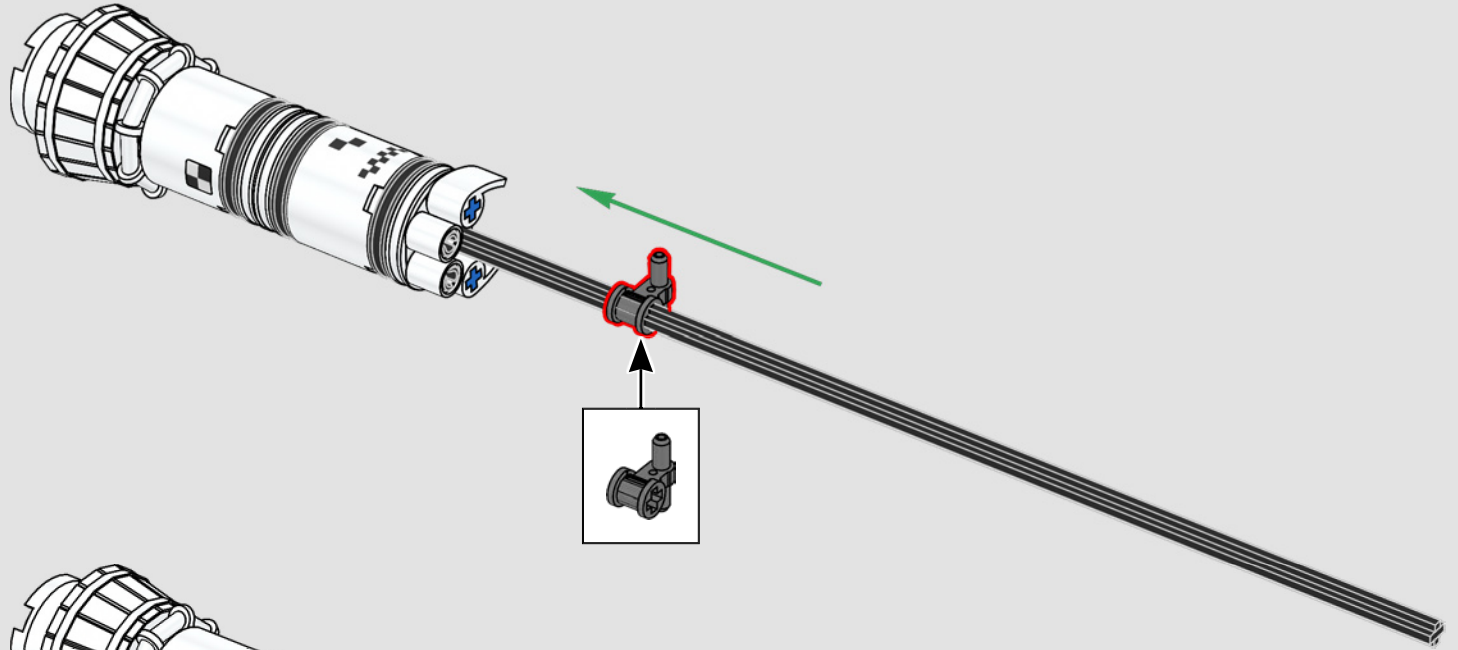

1x



3x

568

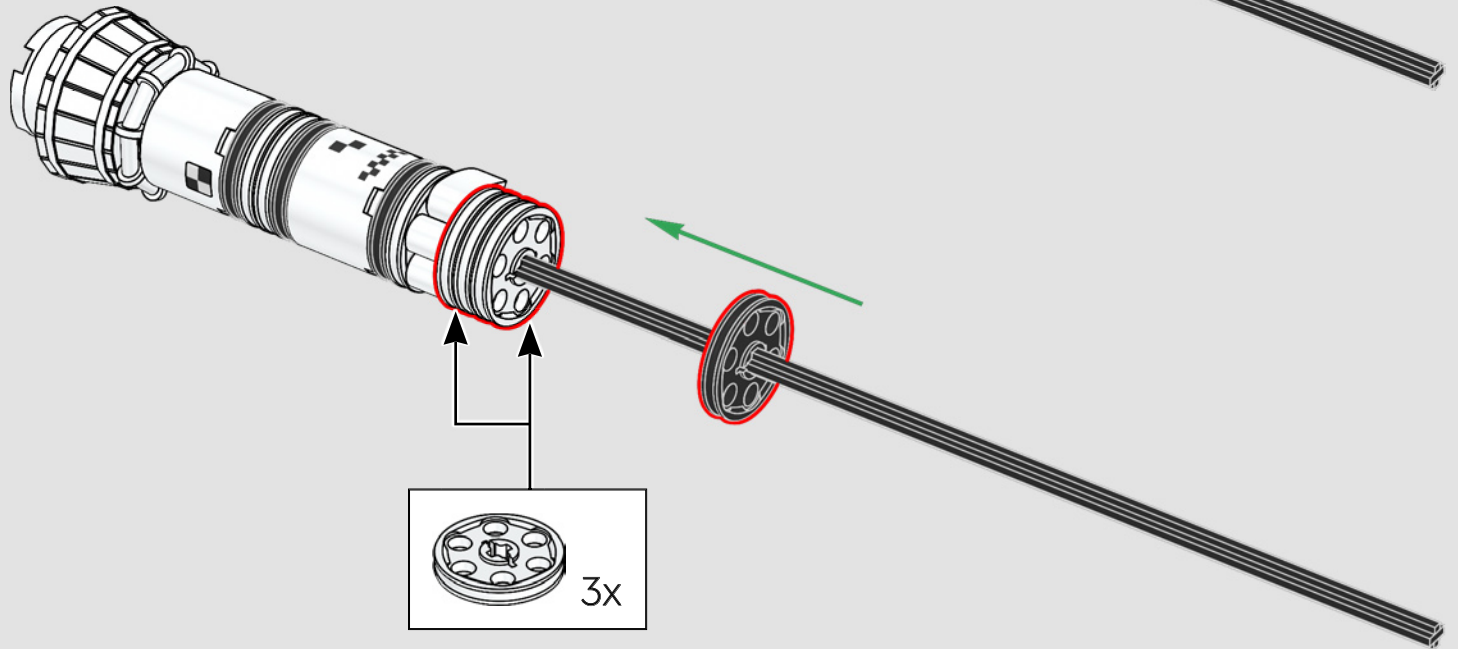

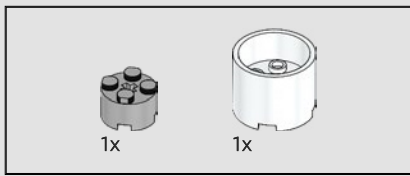

569

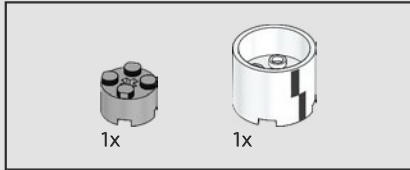
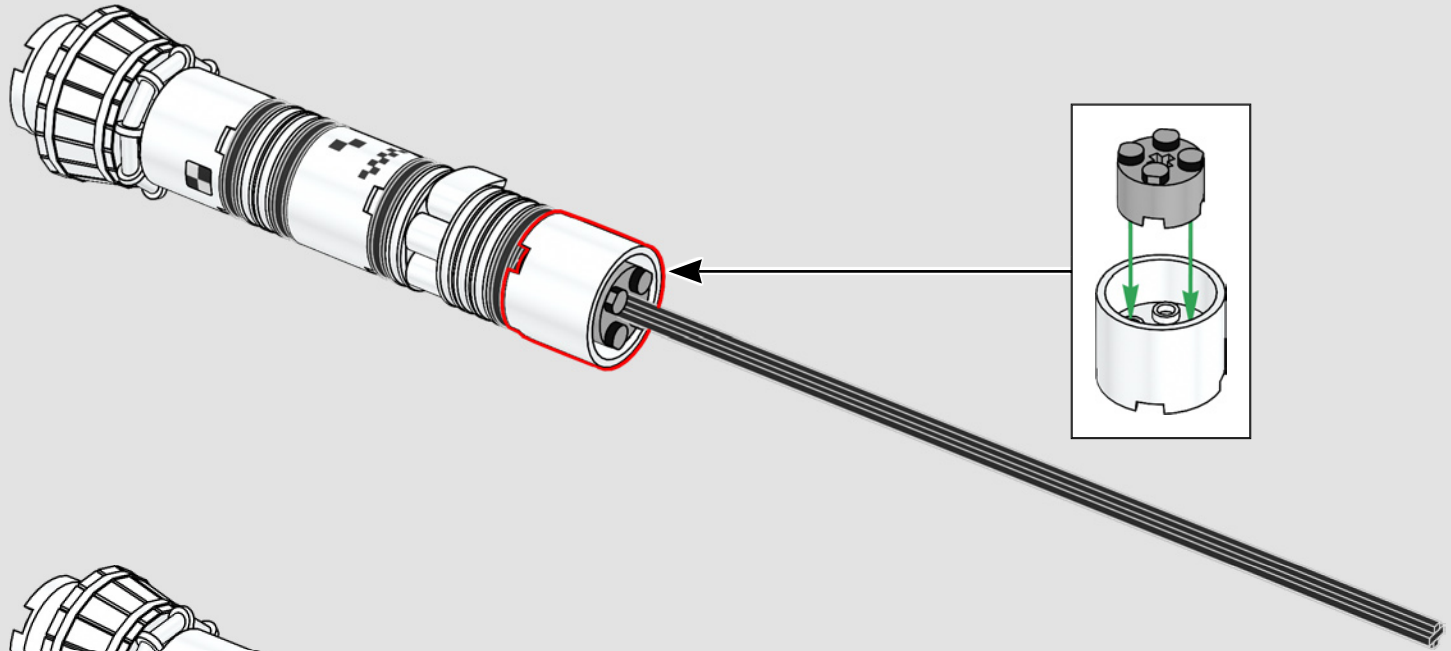

570

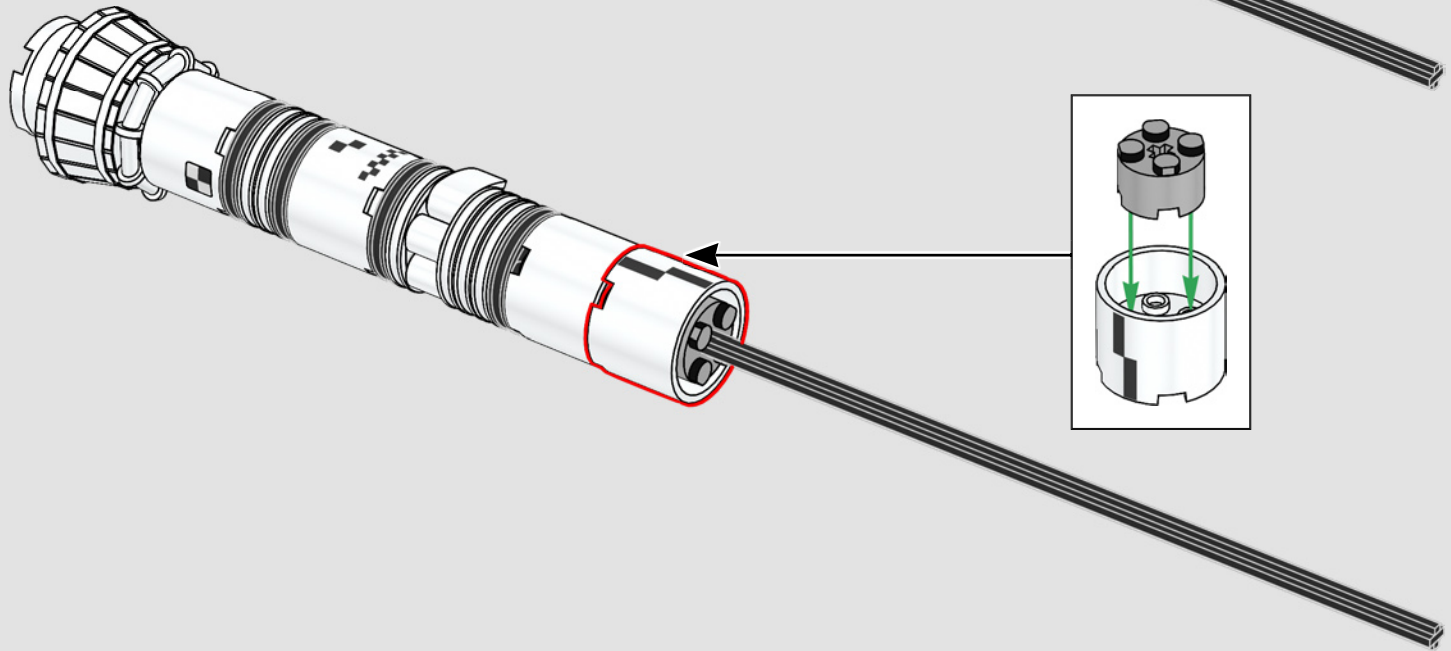

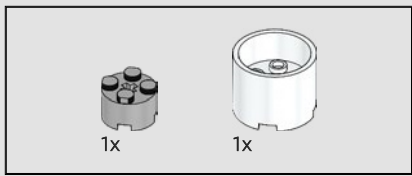

571

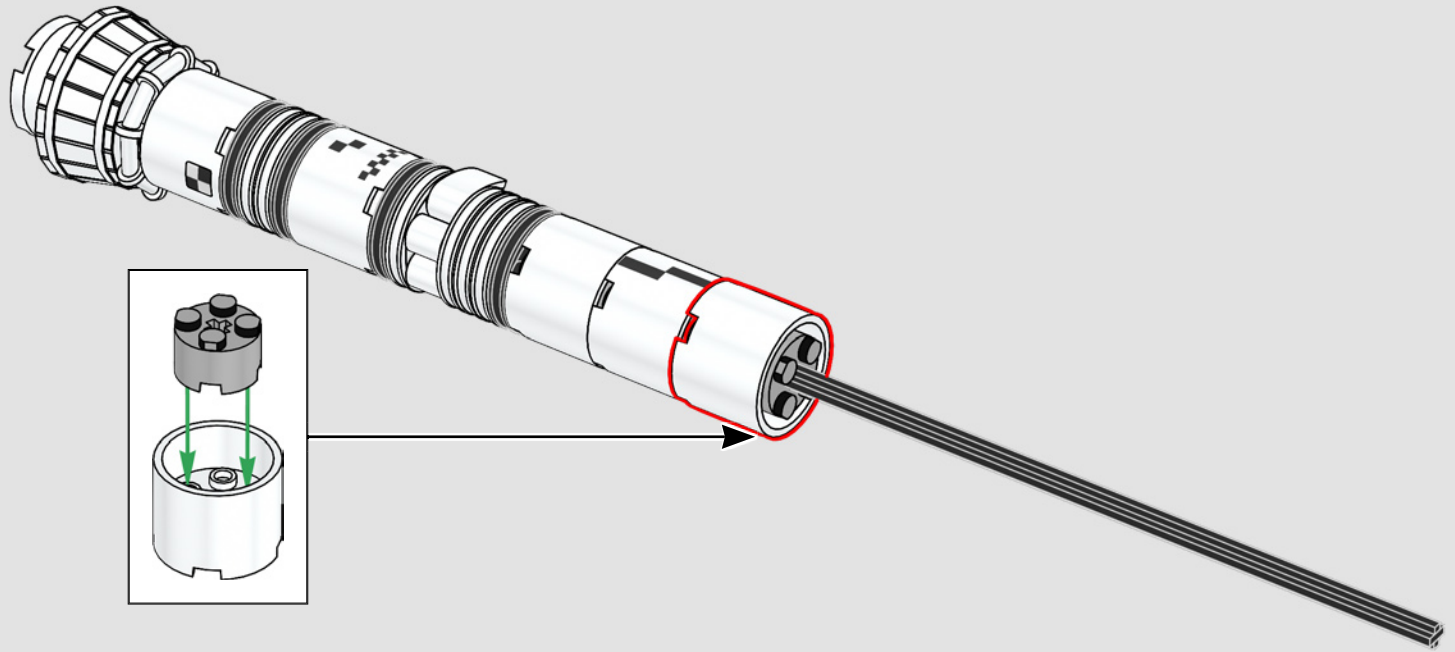

572

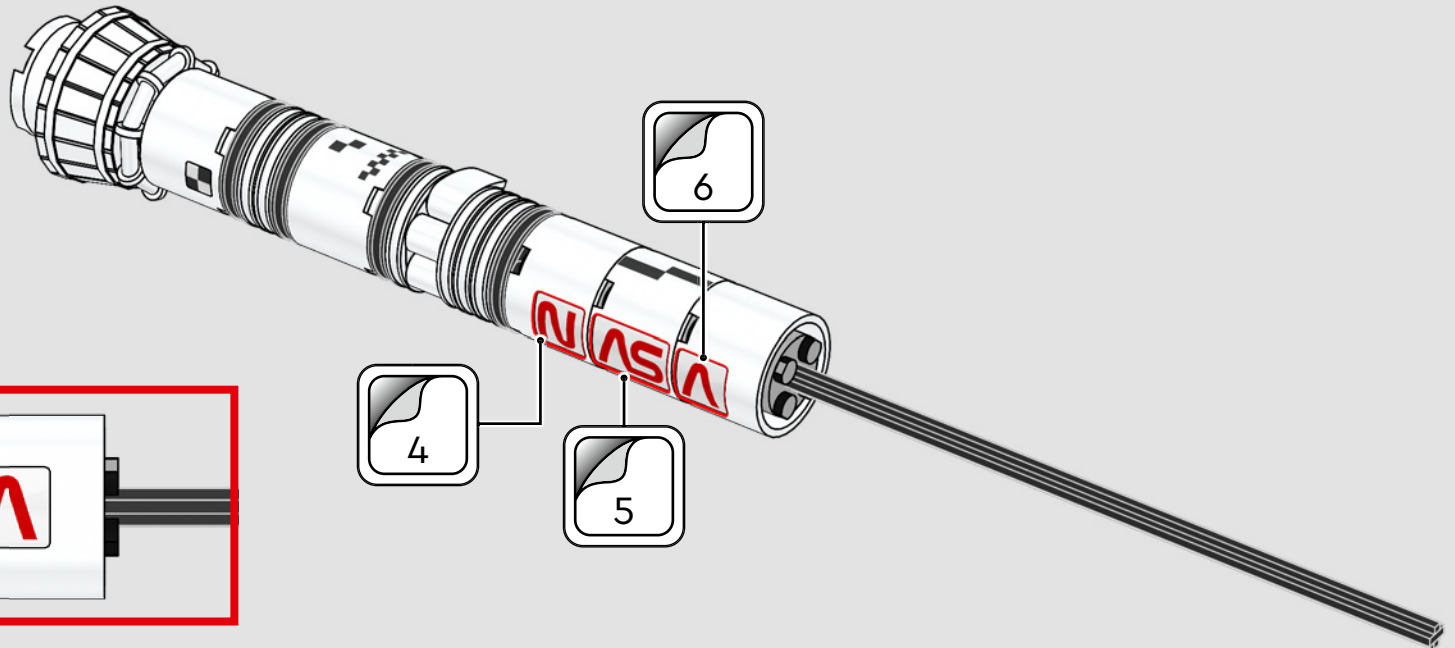

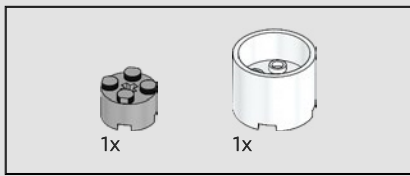

573

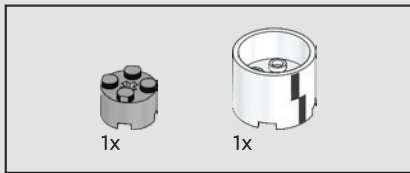
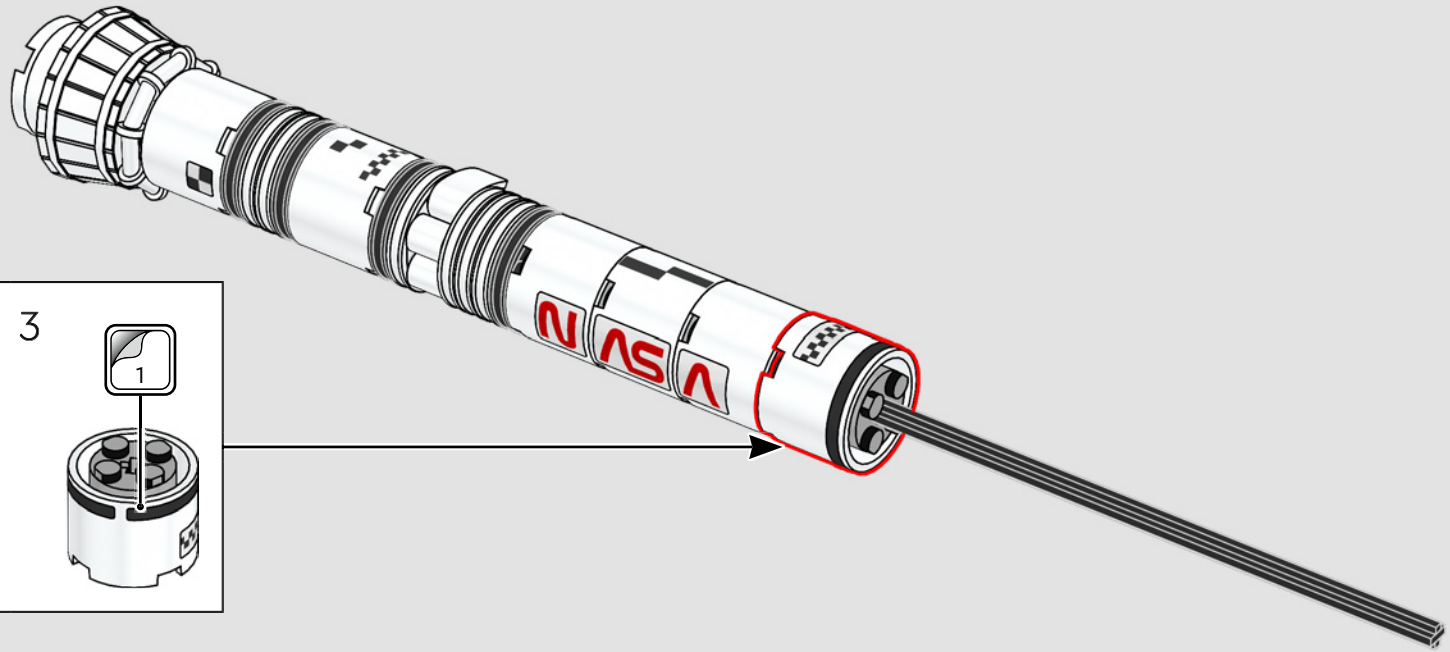
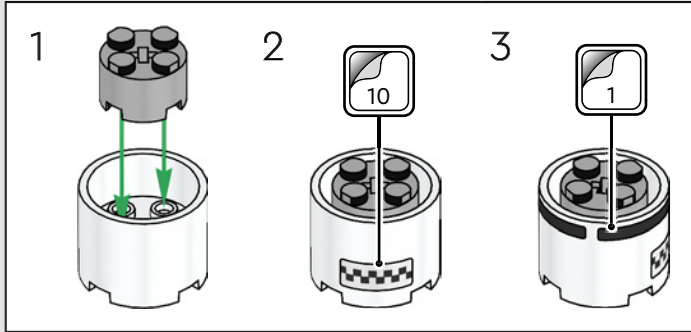

574

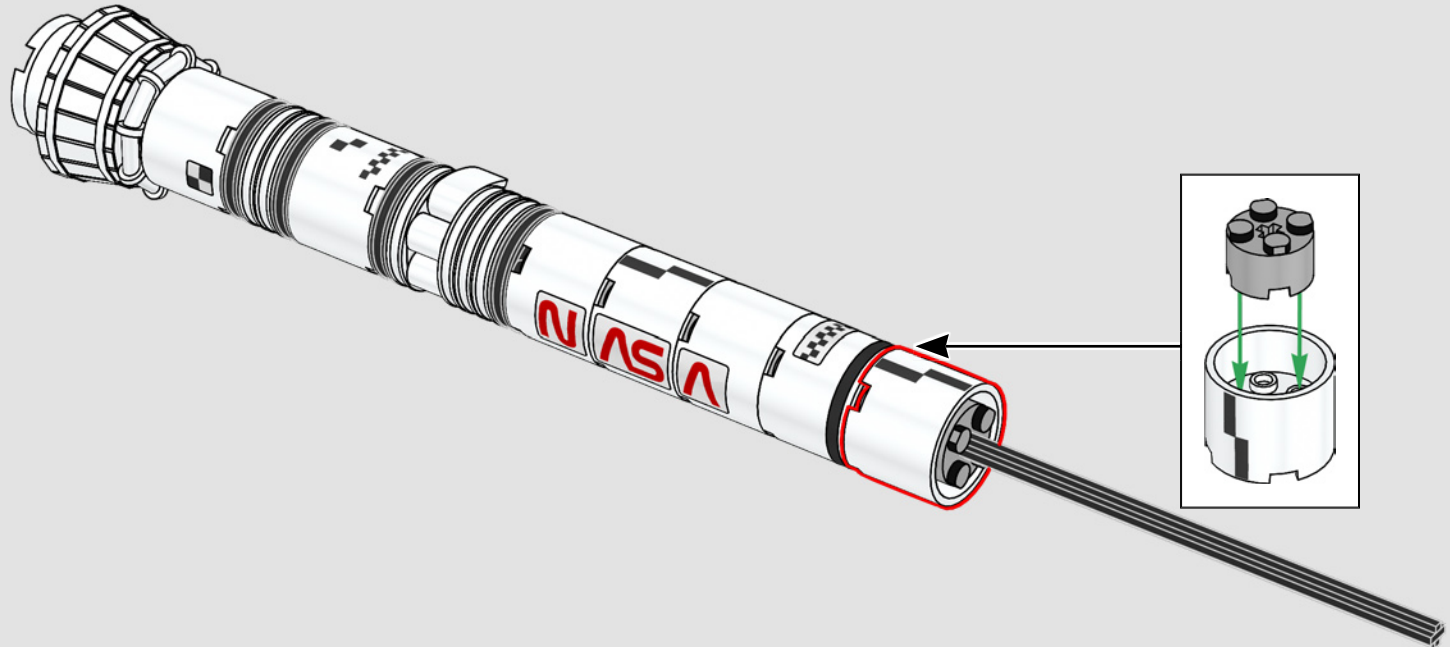

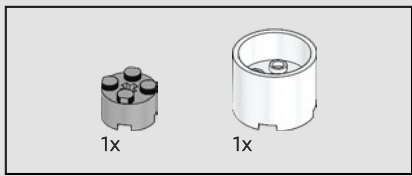

575

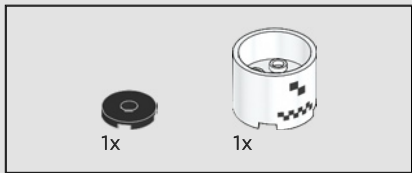
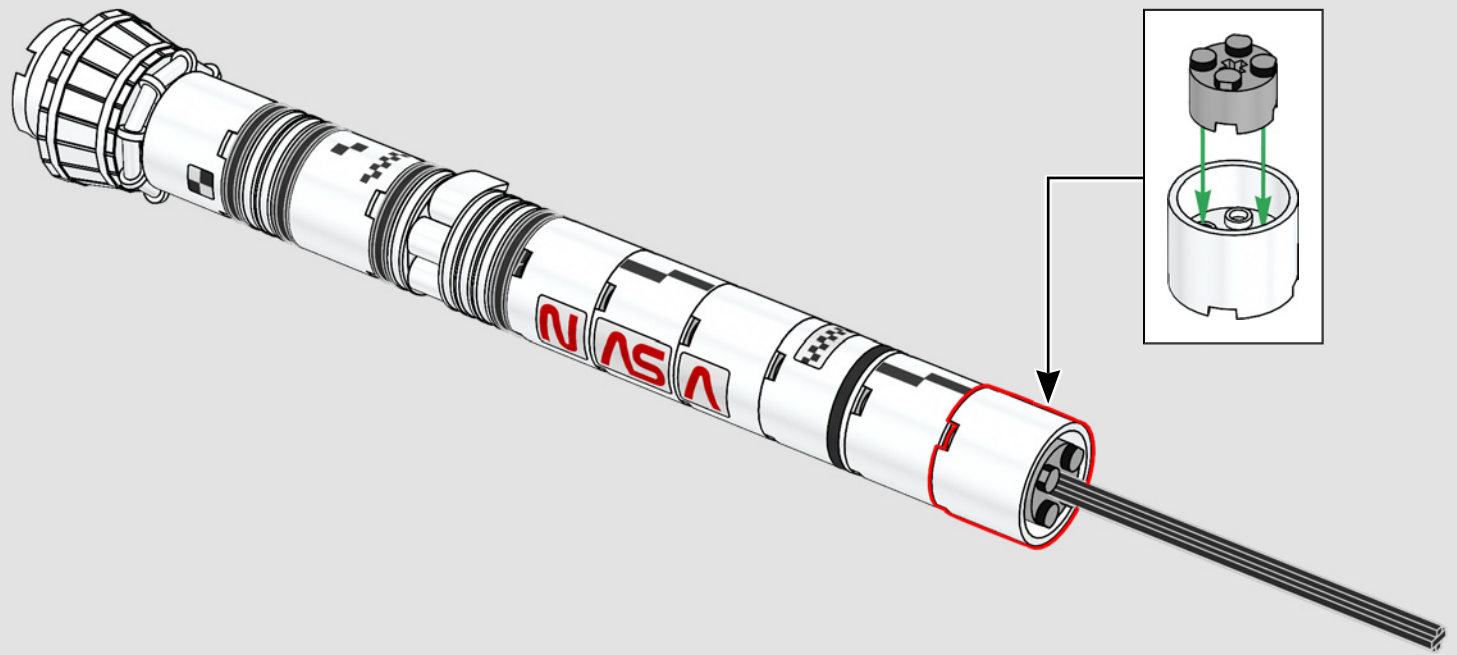

576

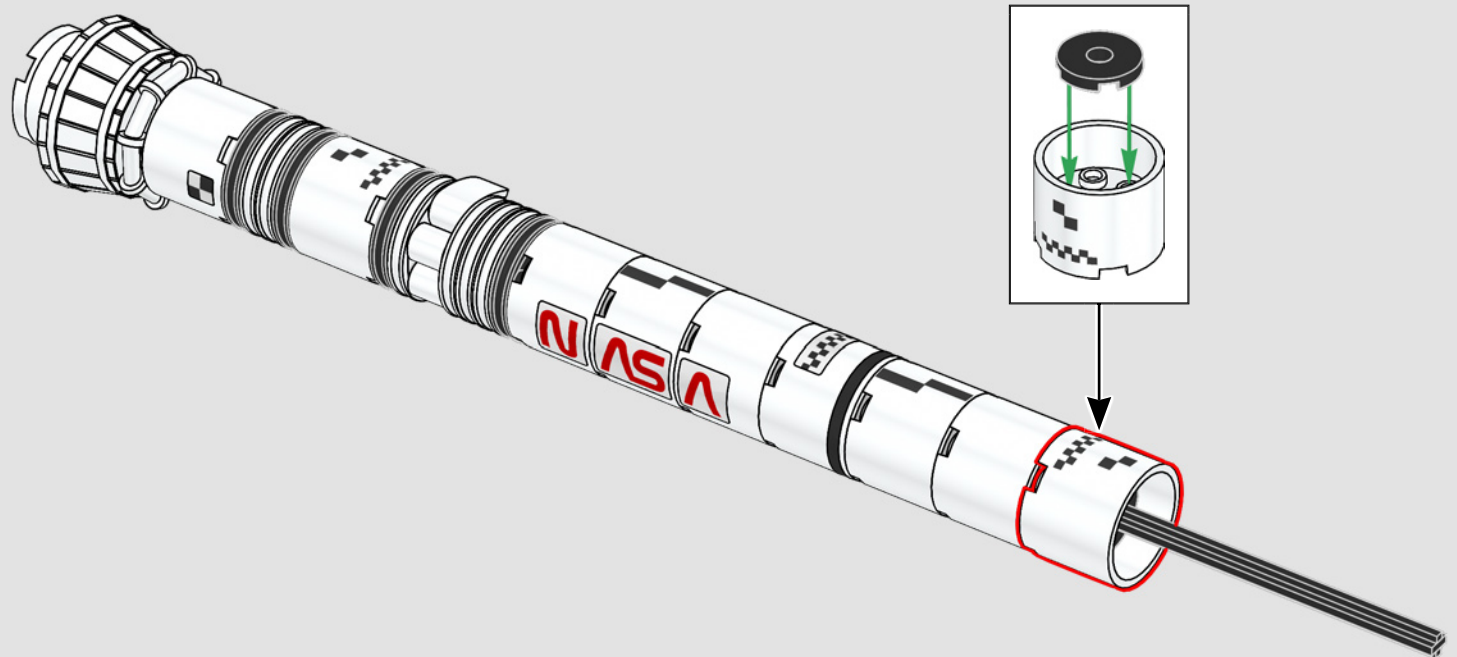

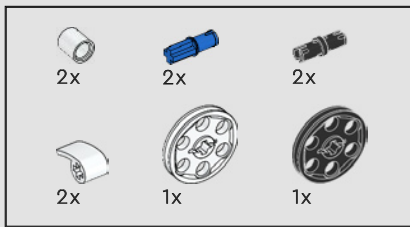

577

1

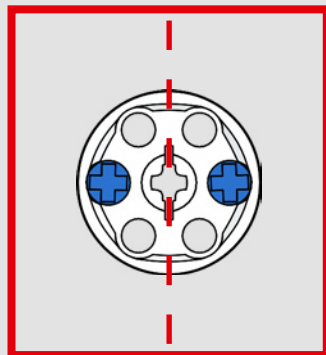
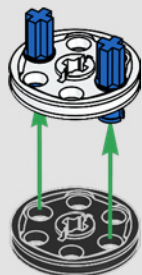

2

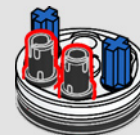

3

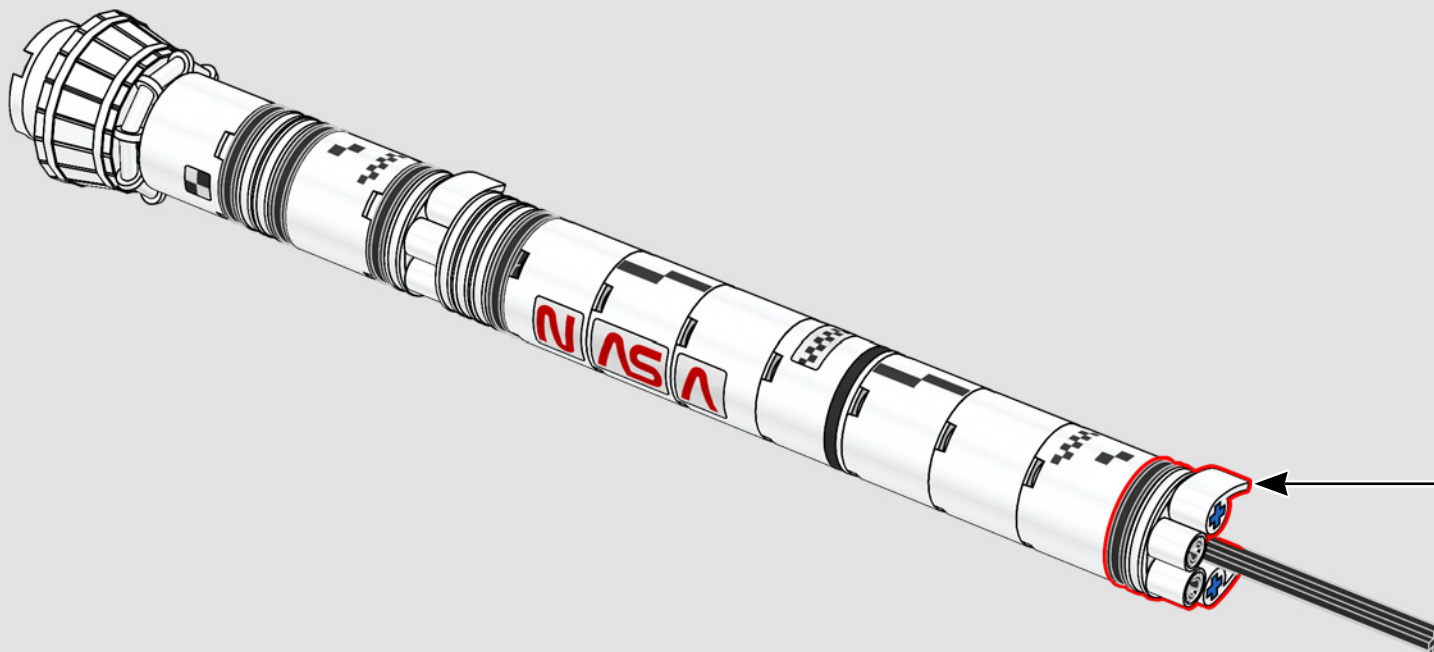



1x

578

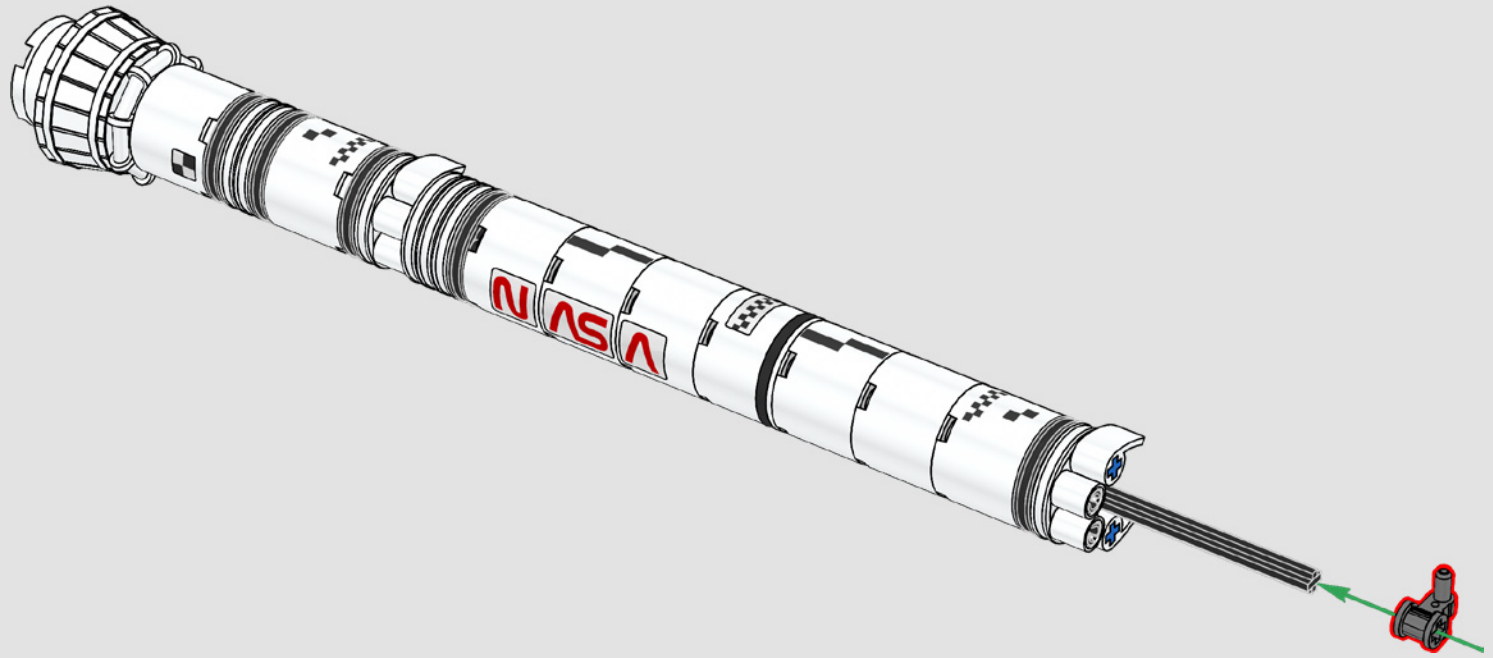

1x



1x

579

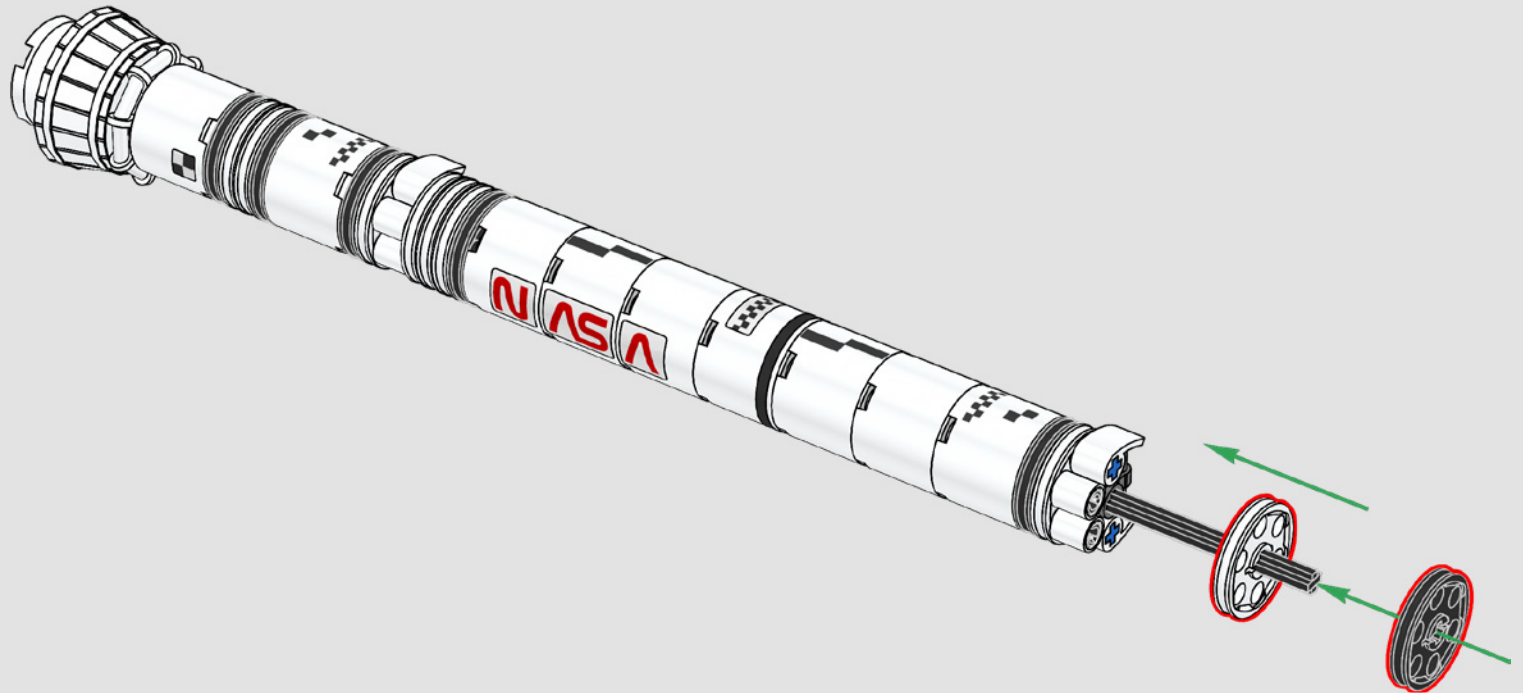

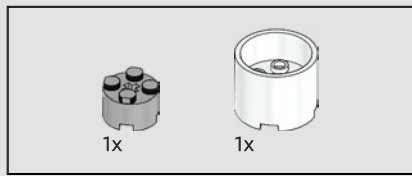

580

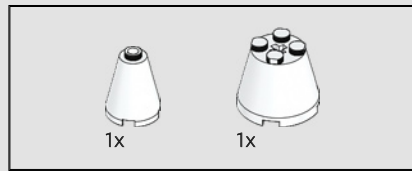
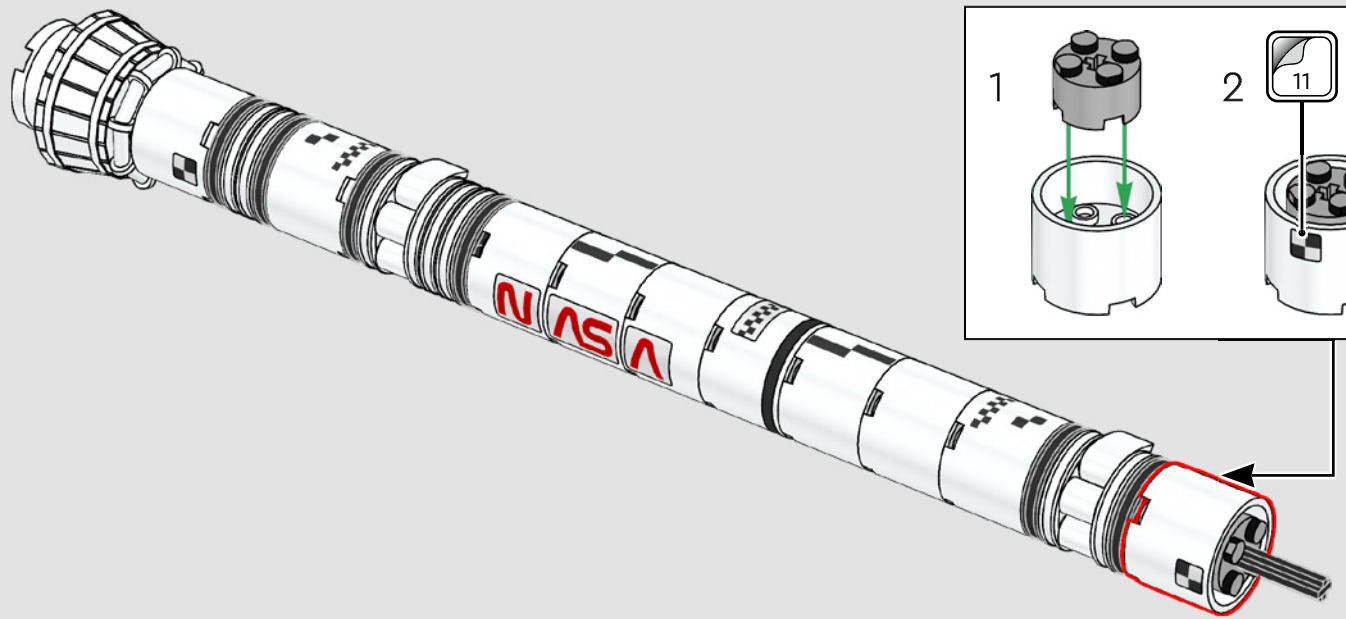

581

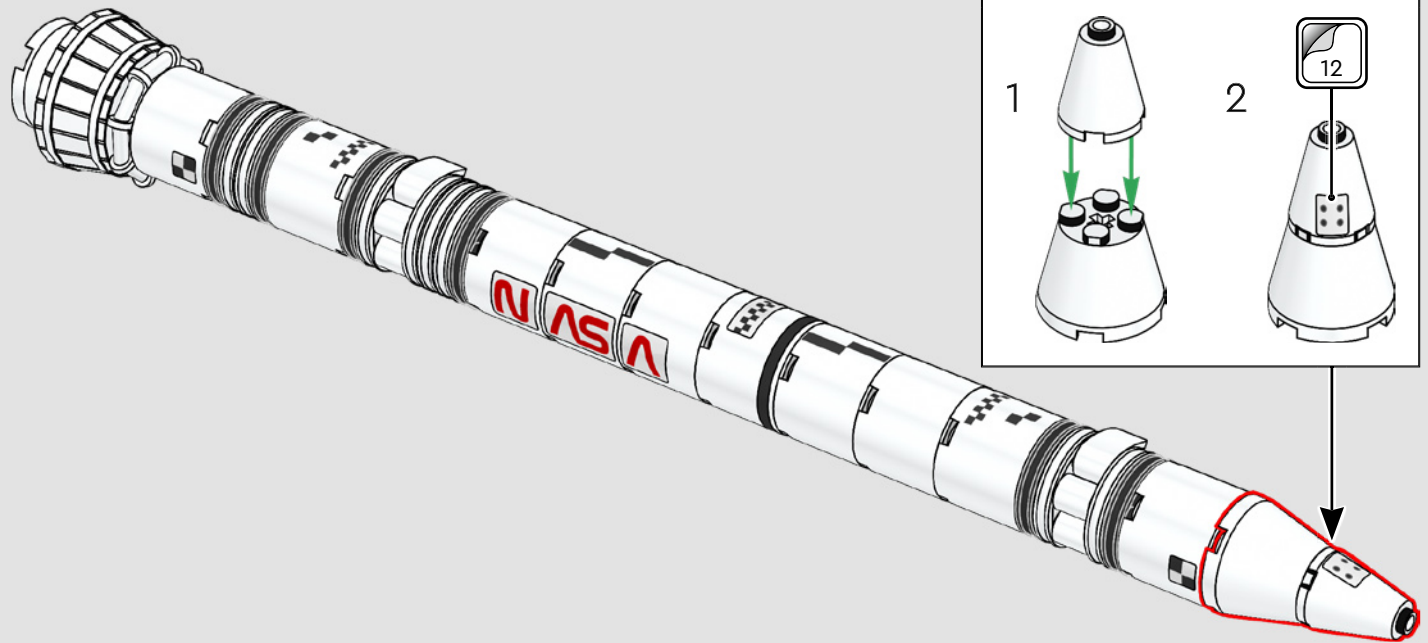

582

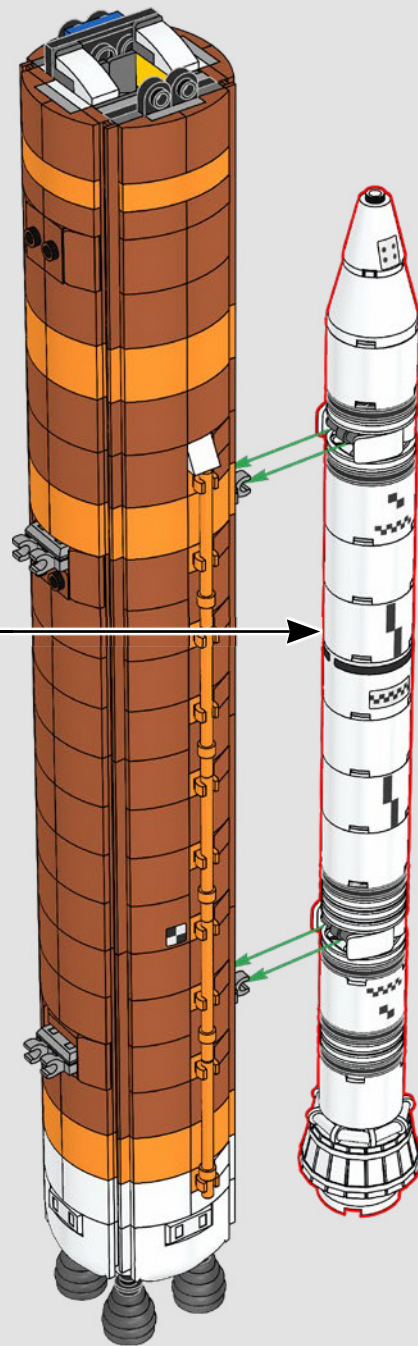

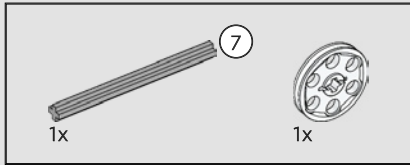
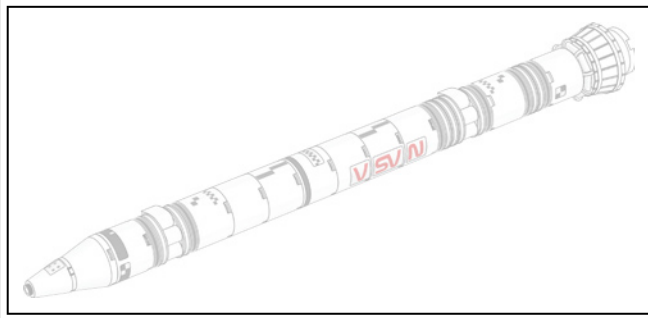

583

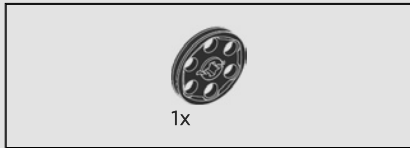
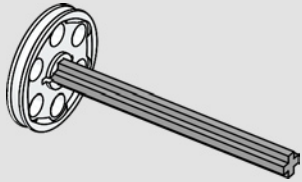

584

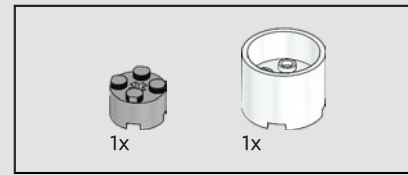
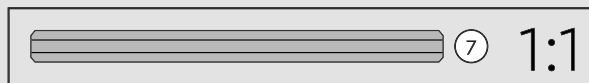
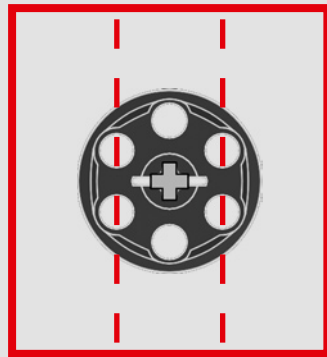
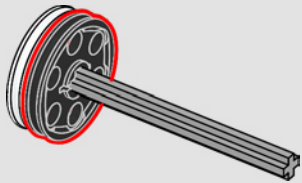

585

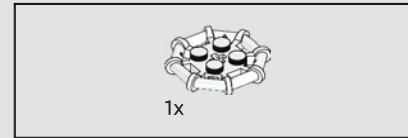
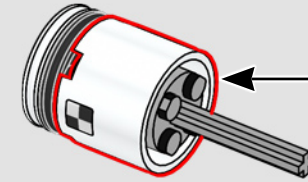
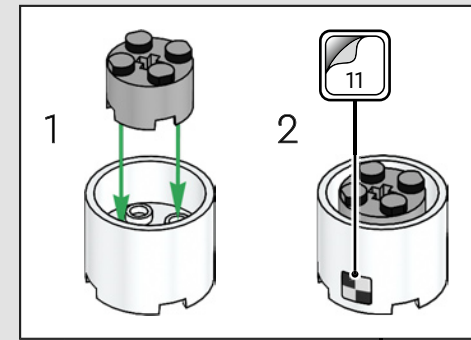

586

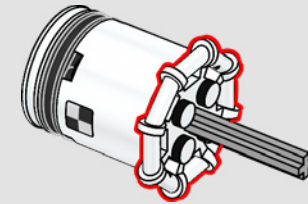

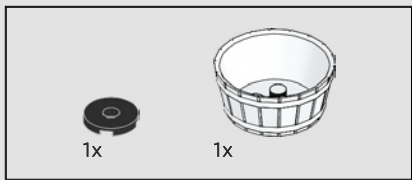

587

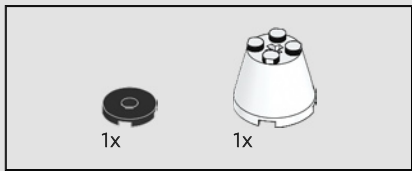
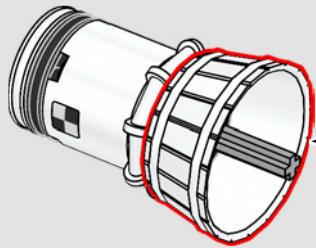
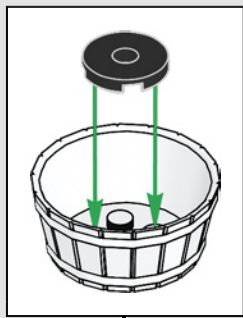

588

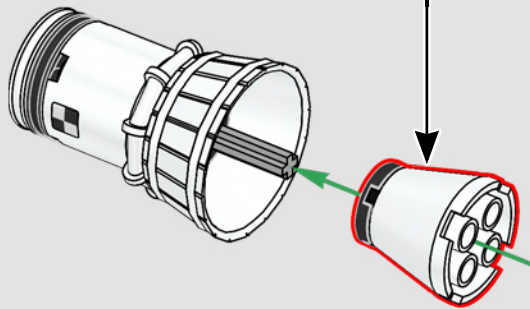
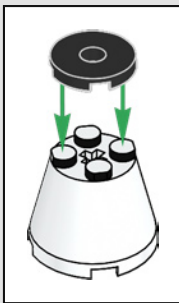

589

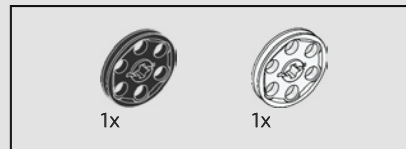
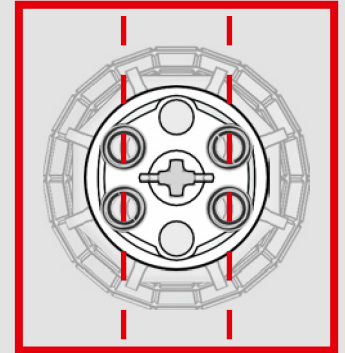
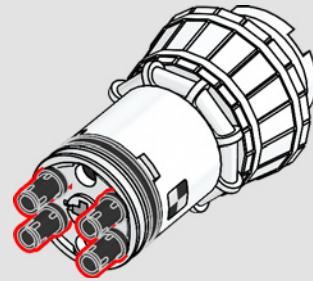

590

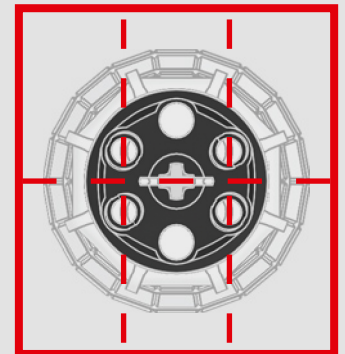
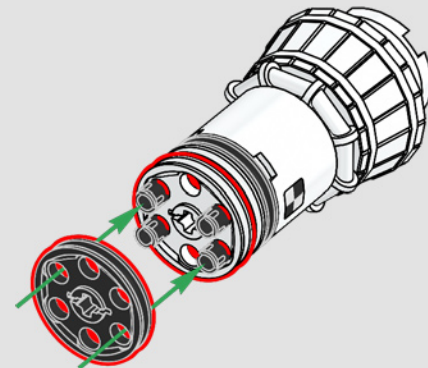

591

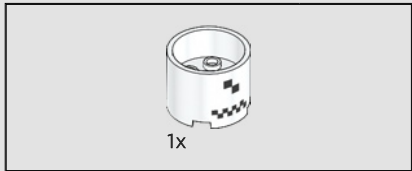
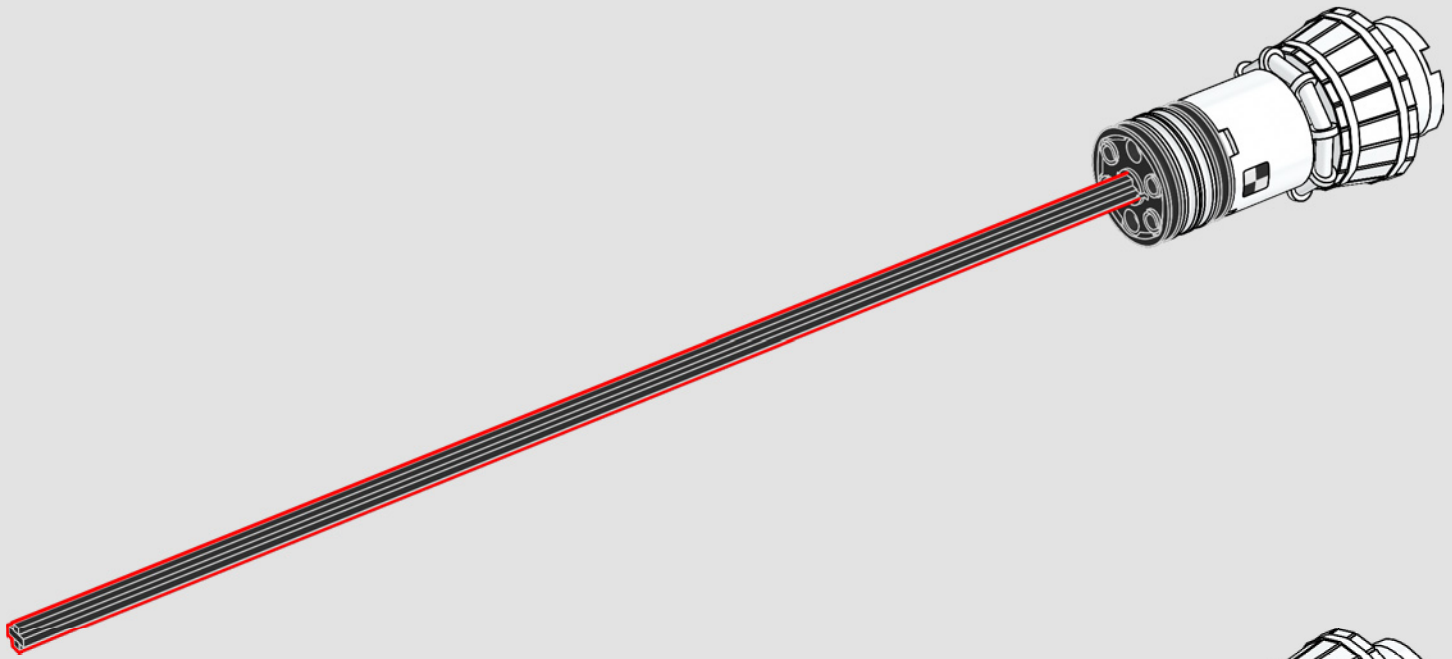

592

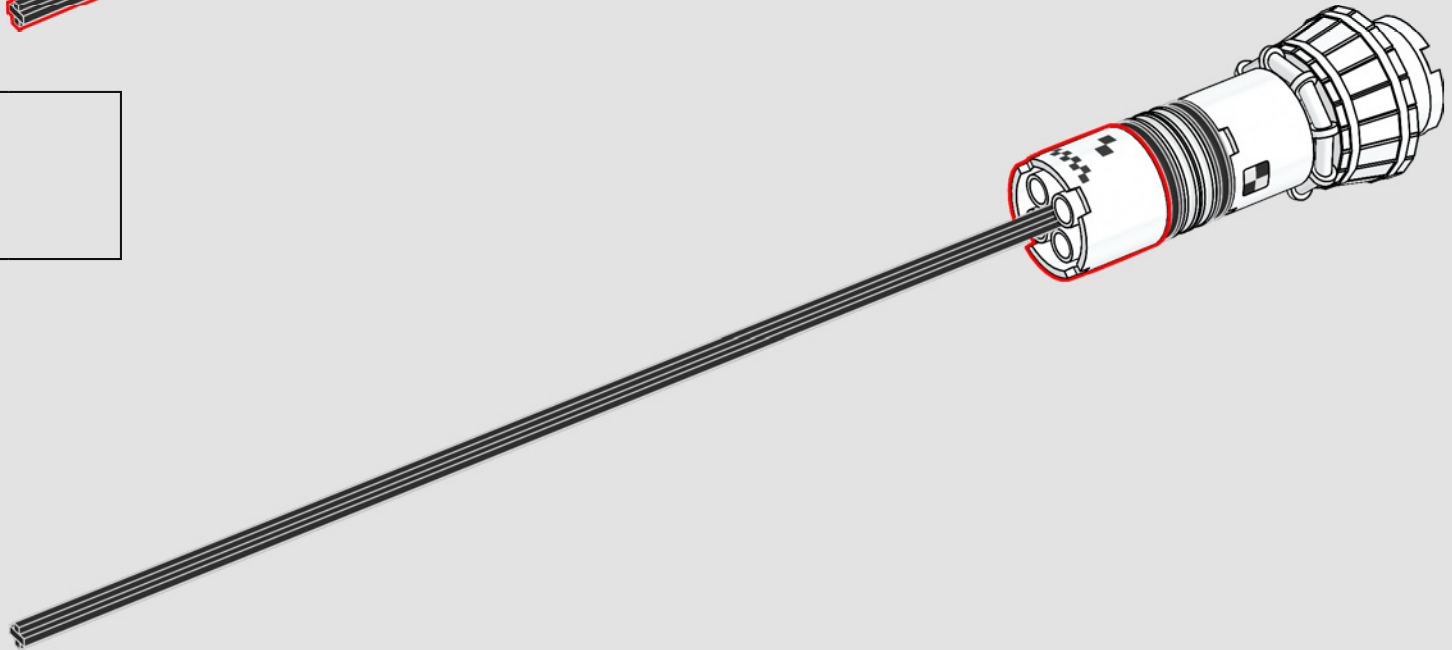

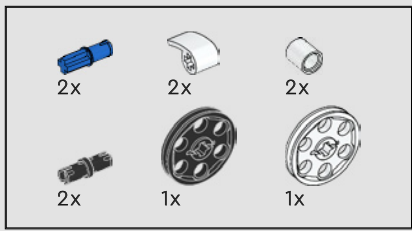

593

1

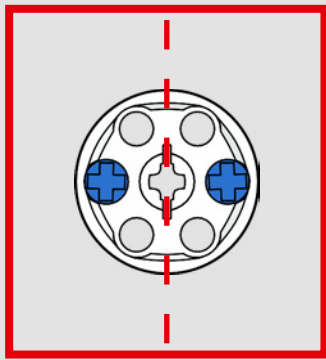
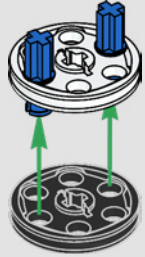

2

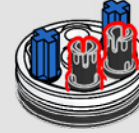

3

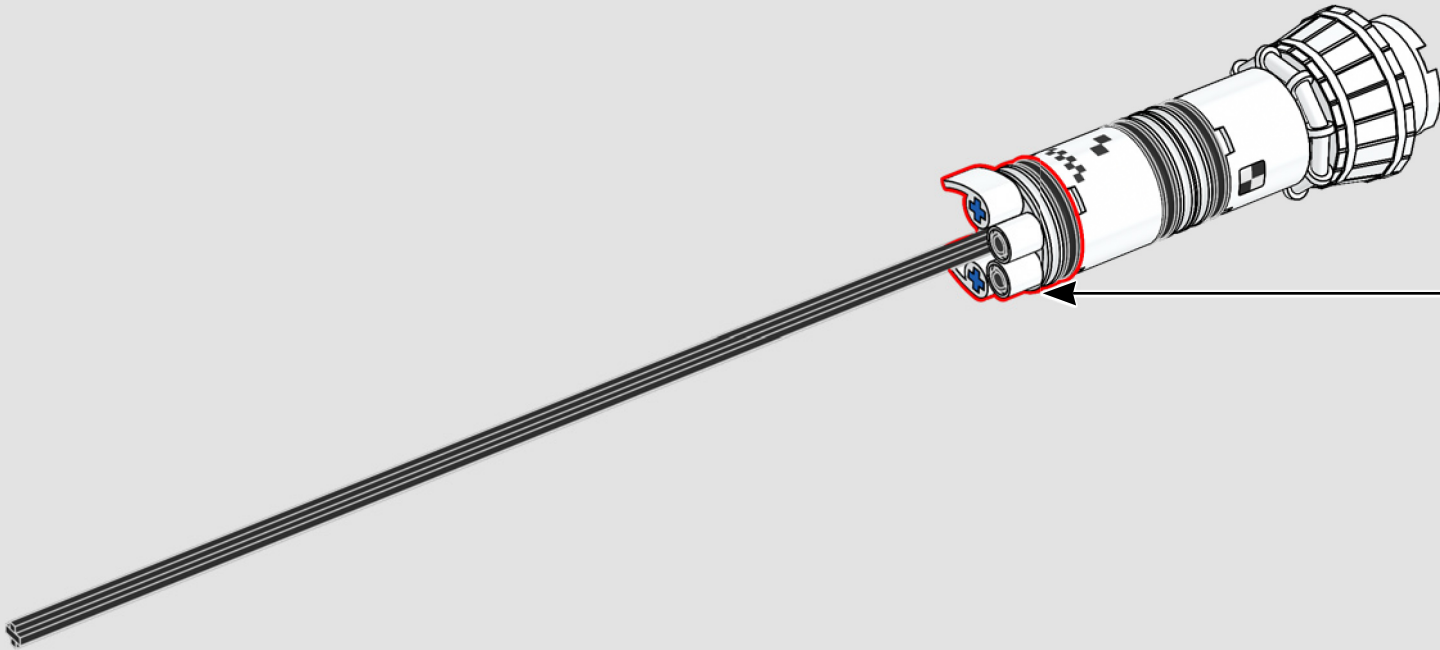
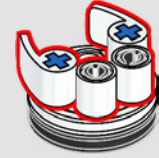



594

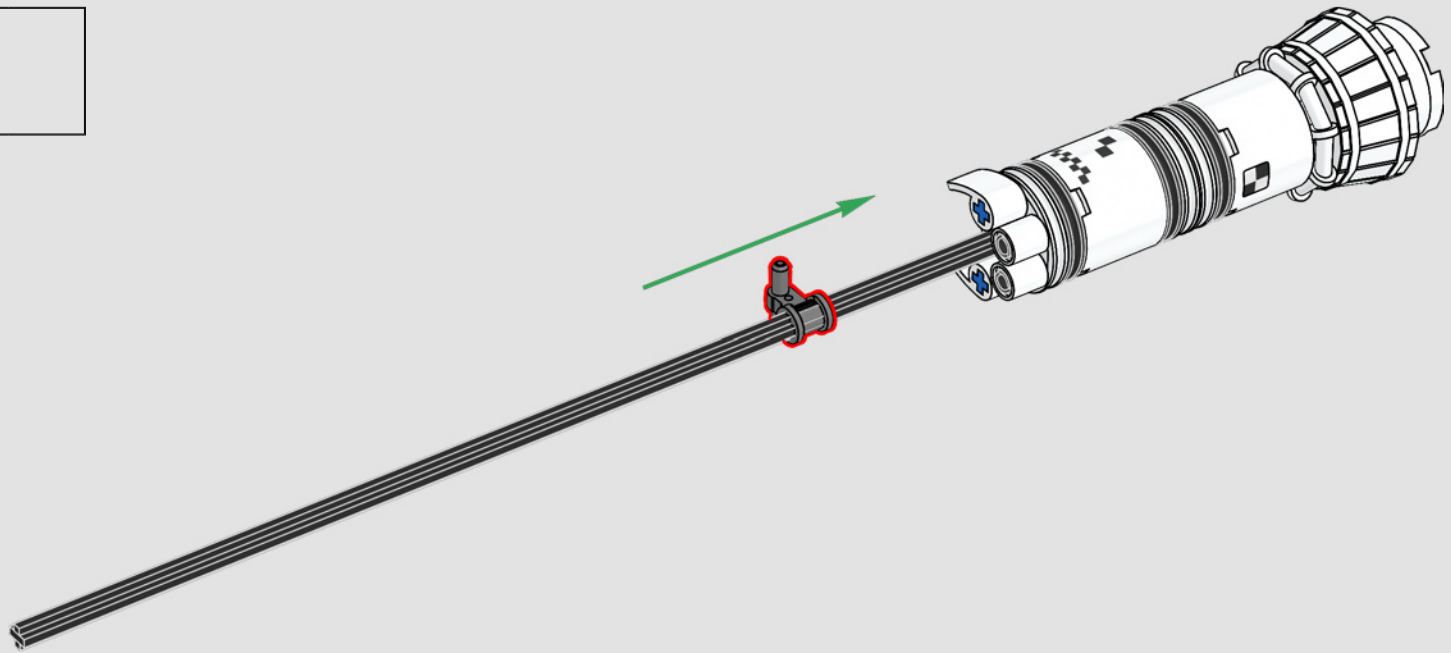

595

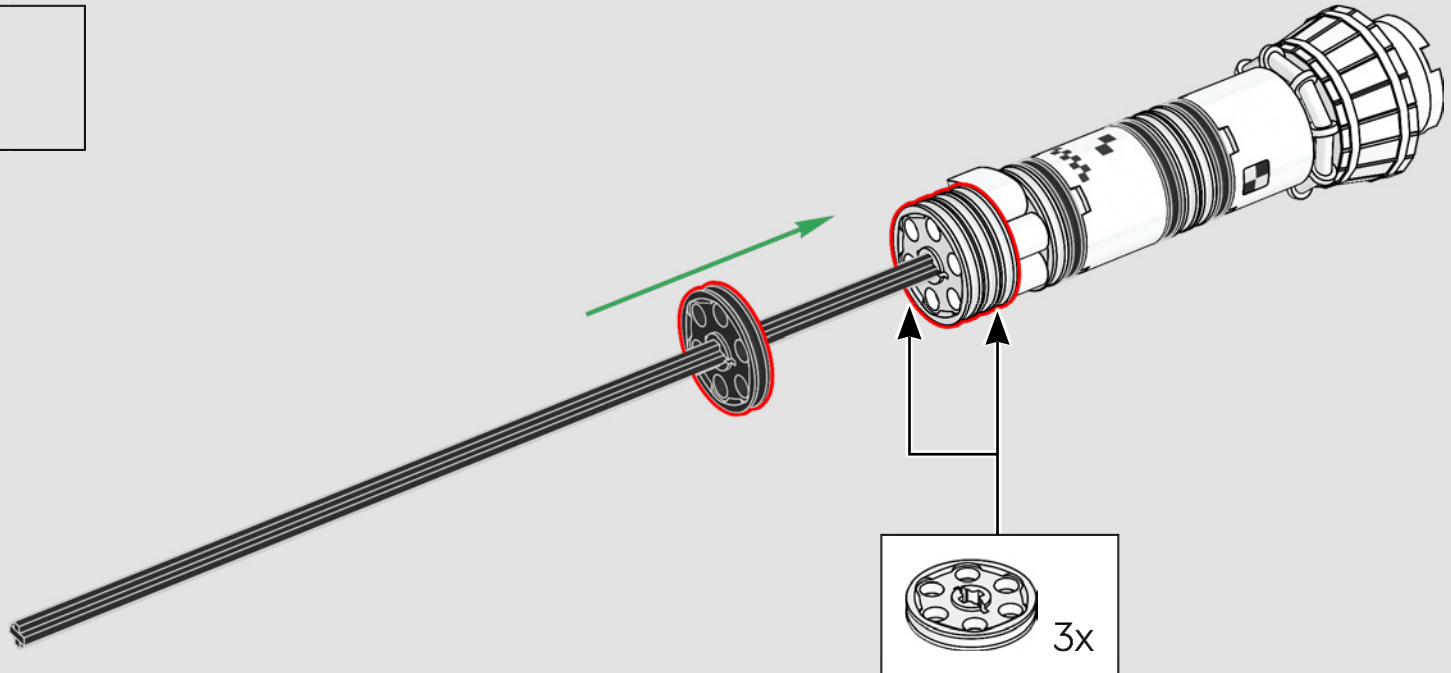

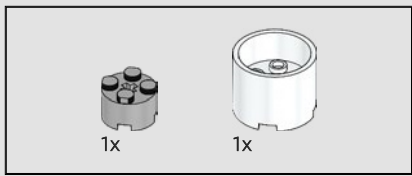

596

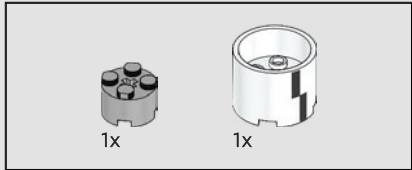
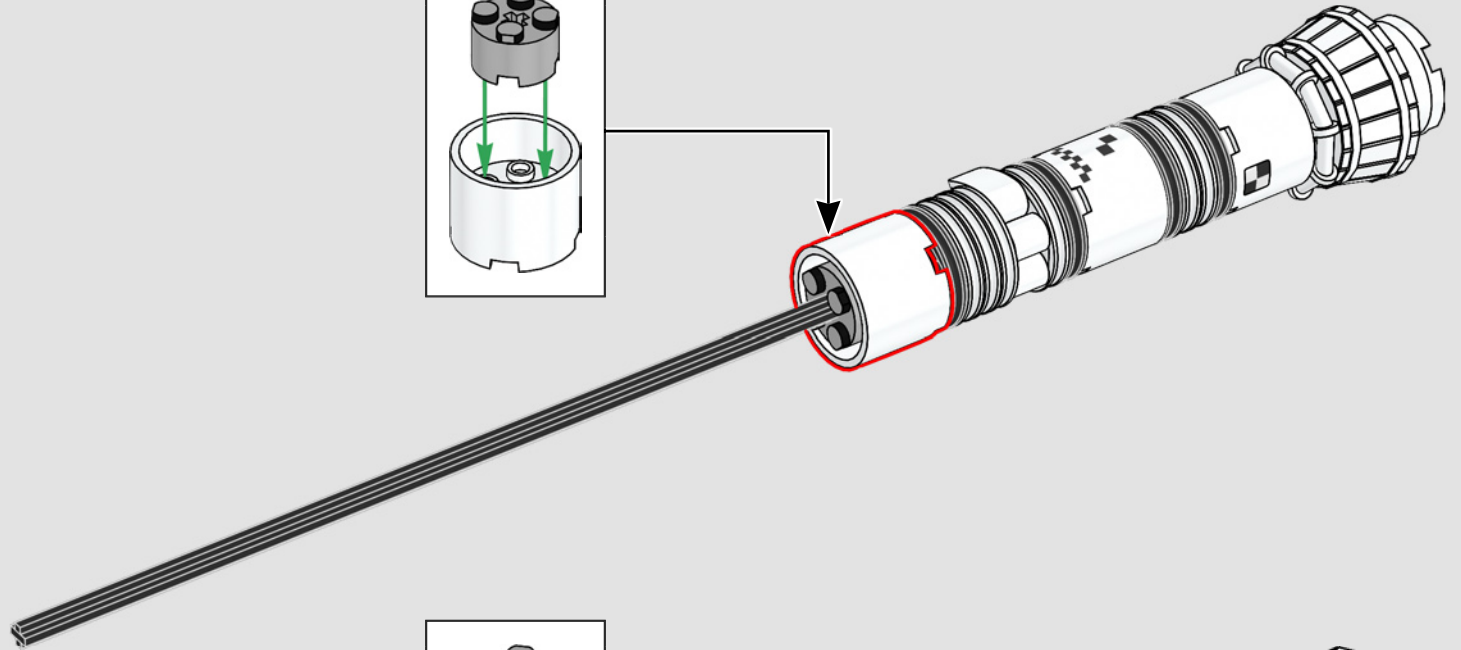
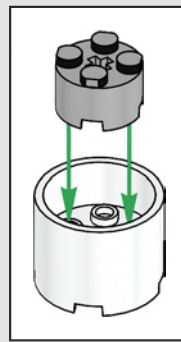

597

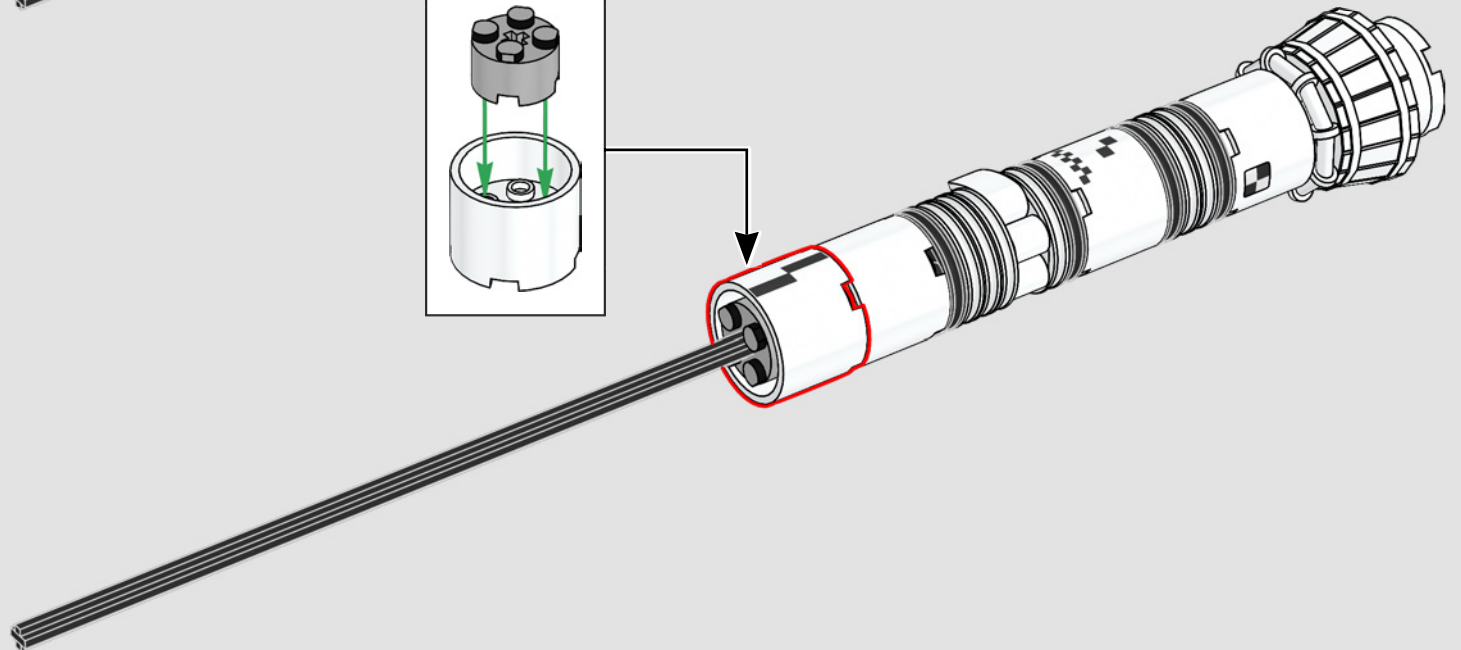
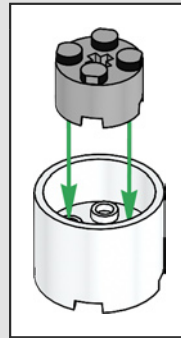

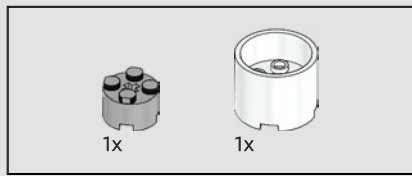

598

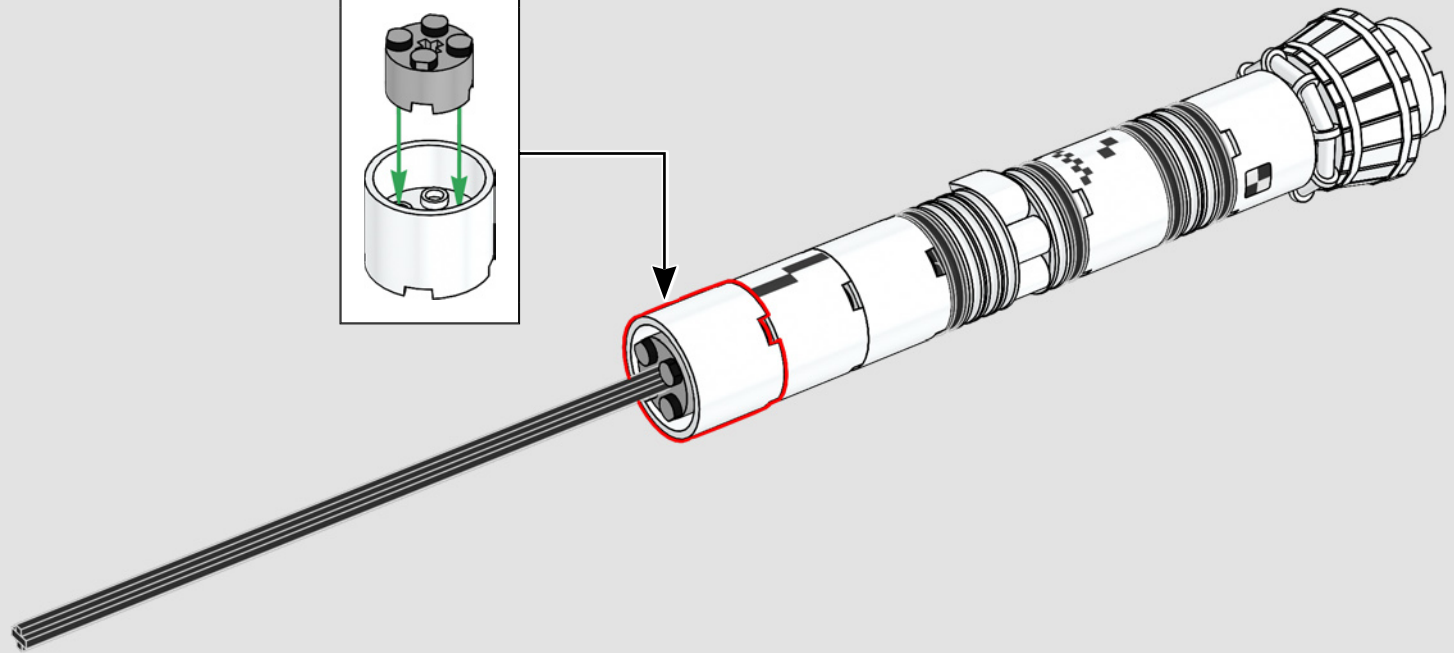
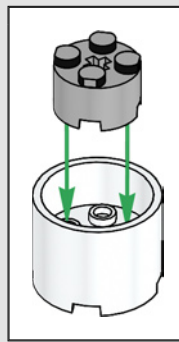

599

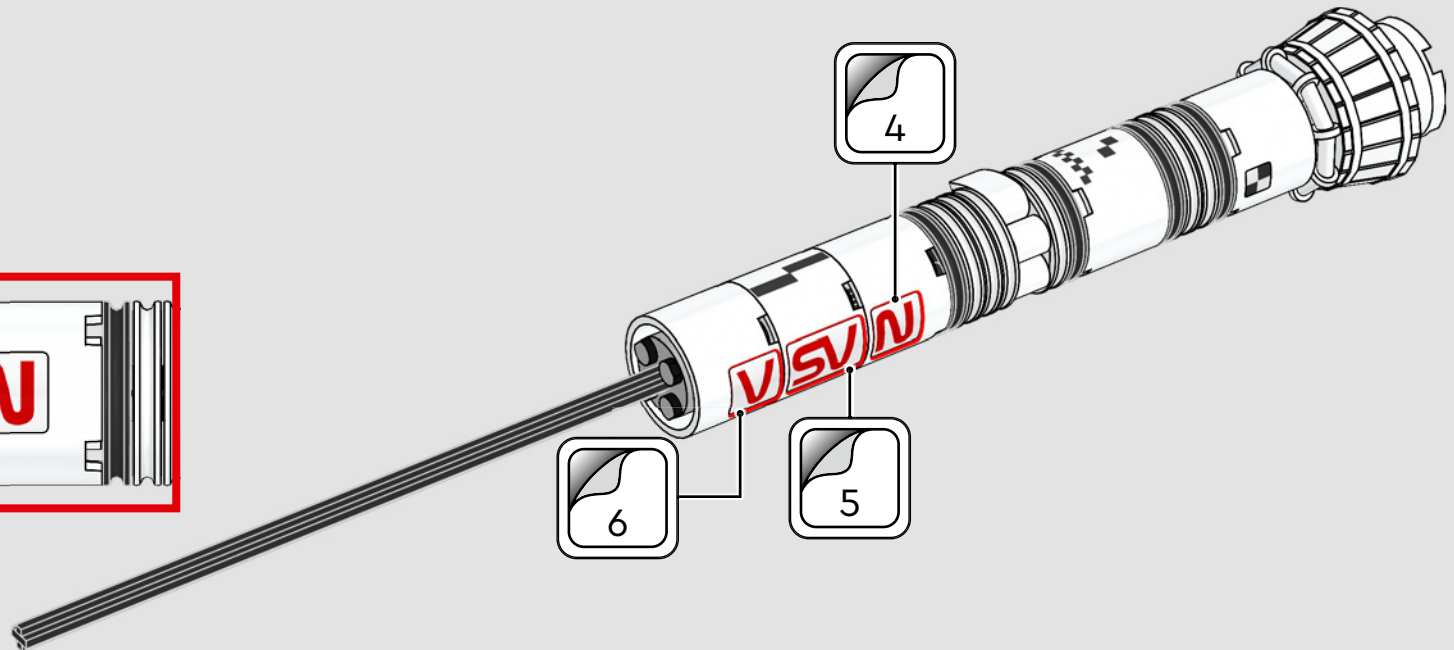
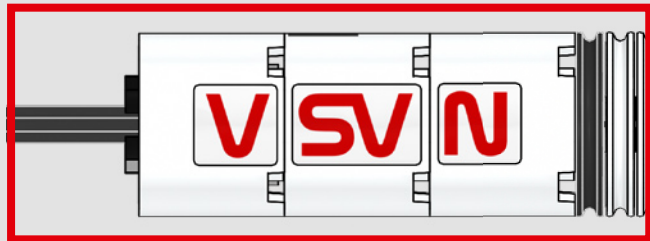

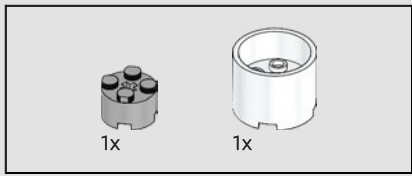

600

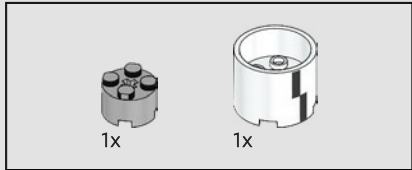
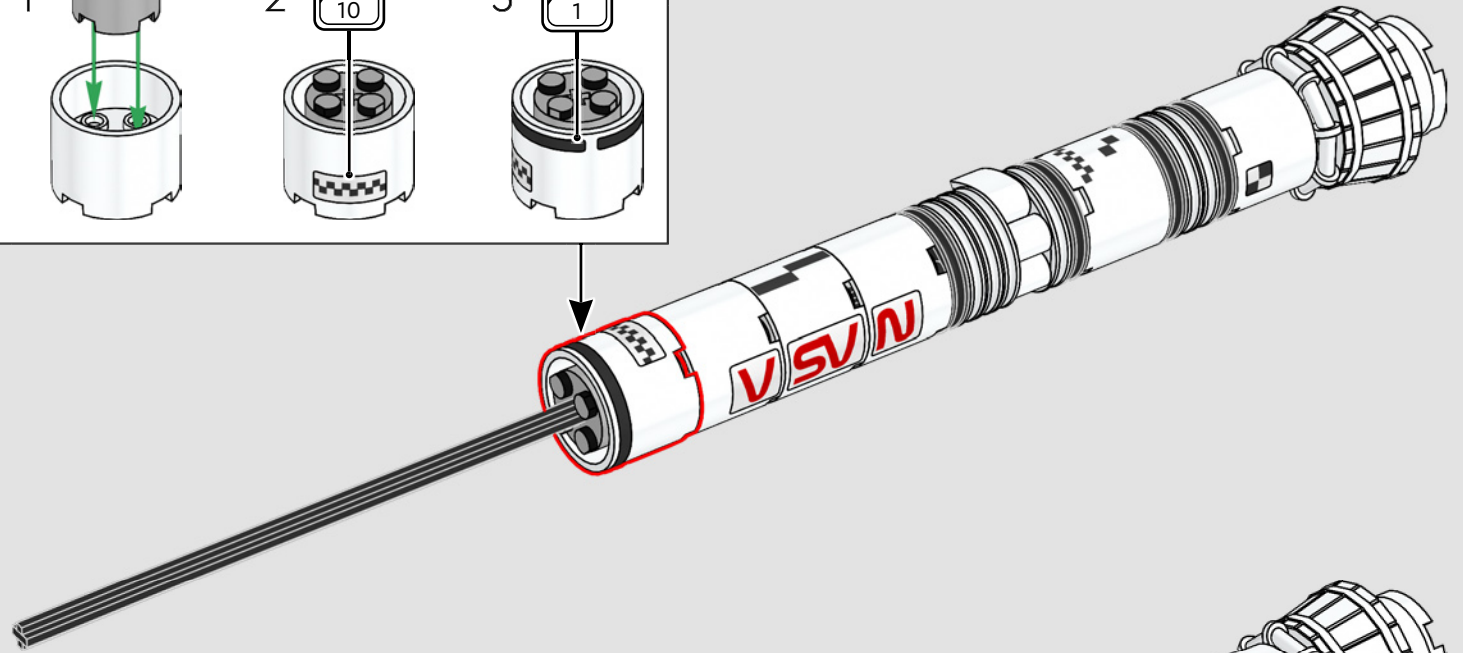
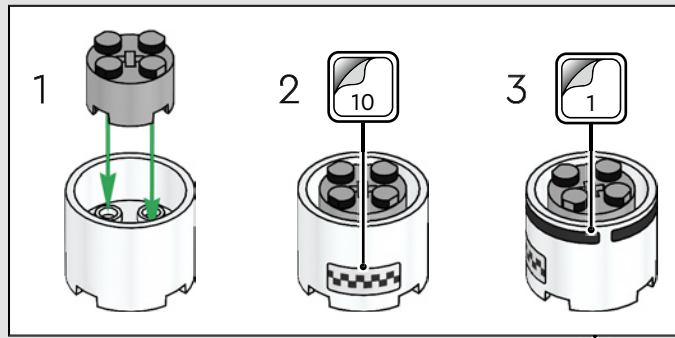

601

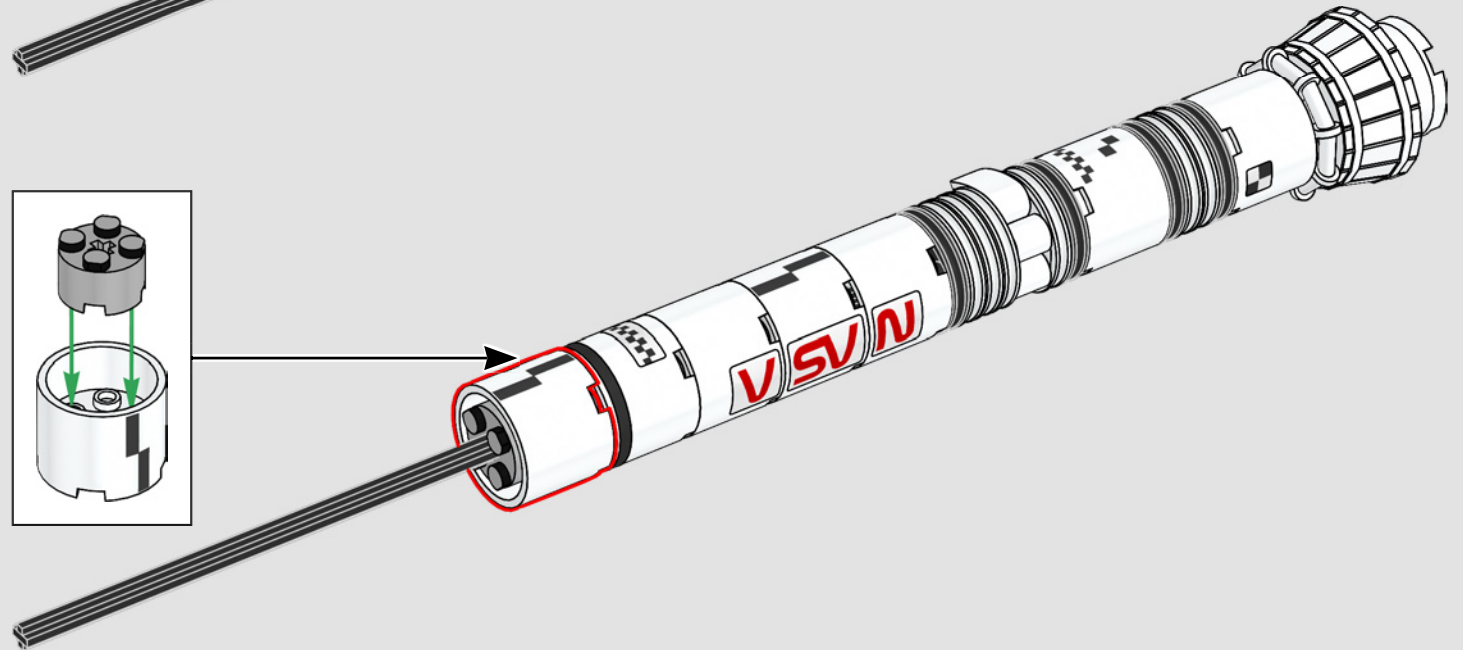
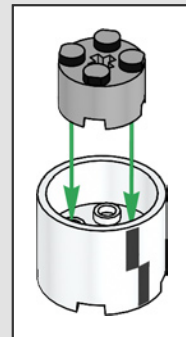

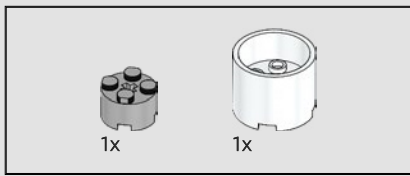

602

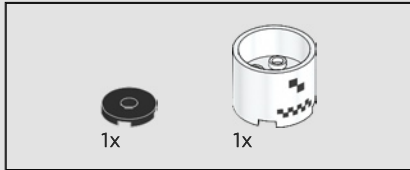
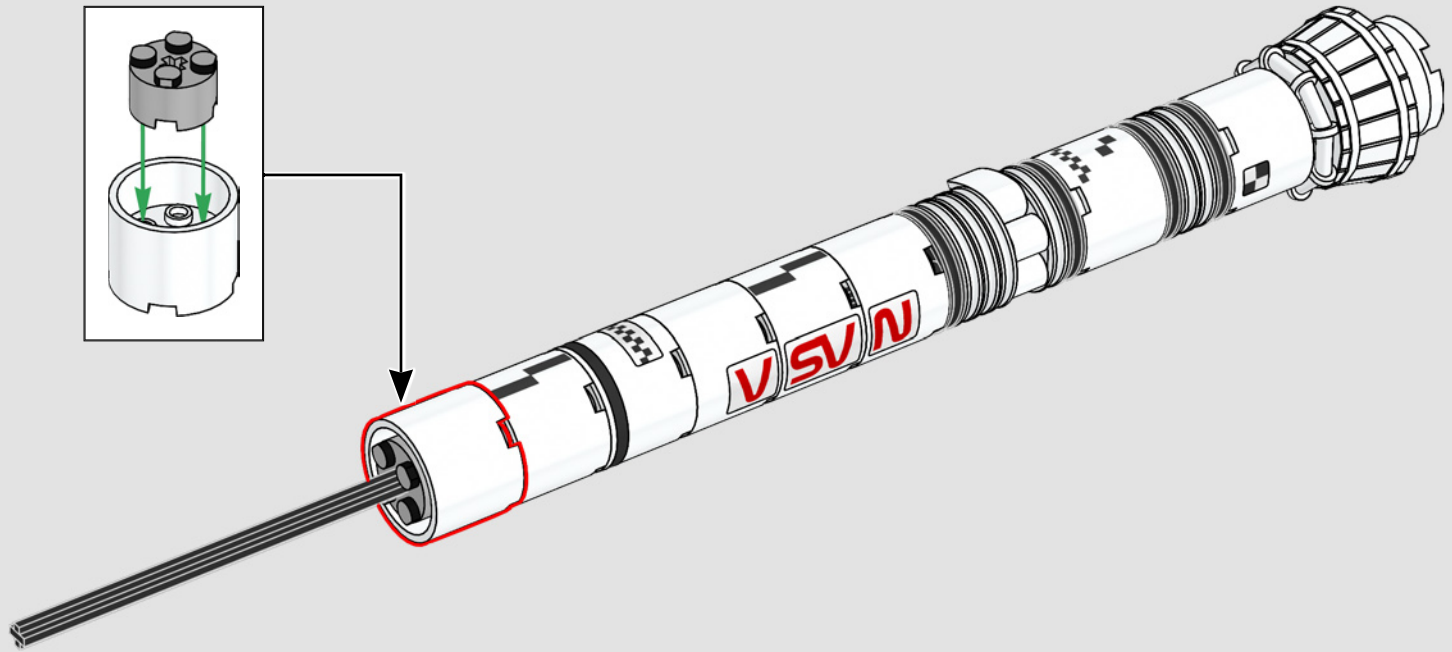
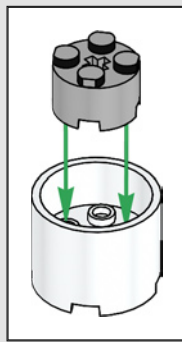

603

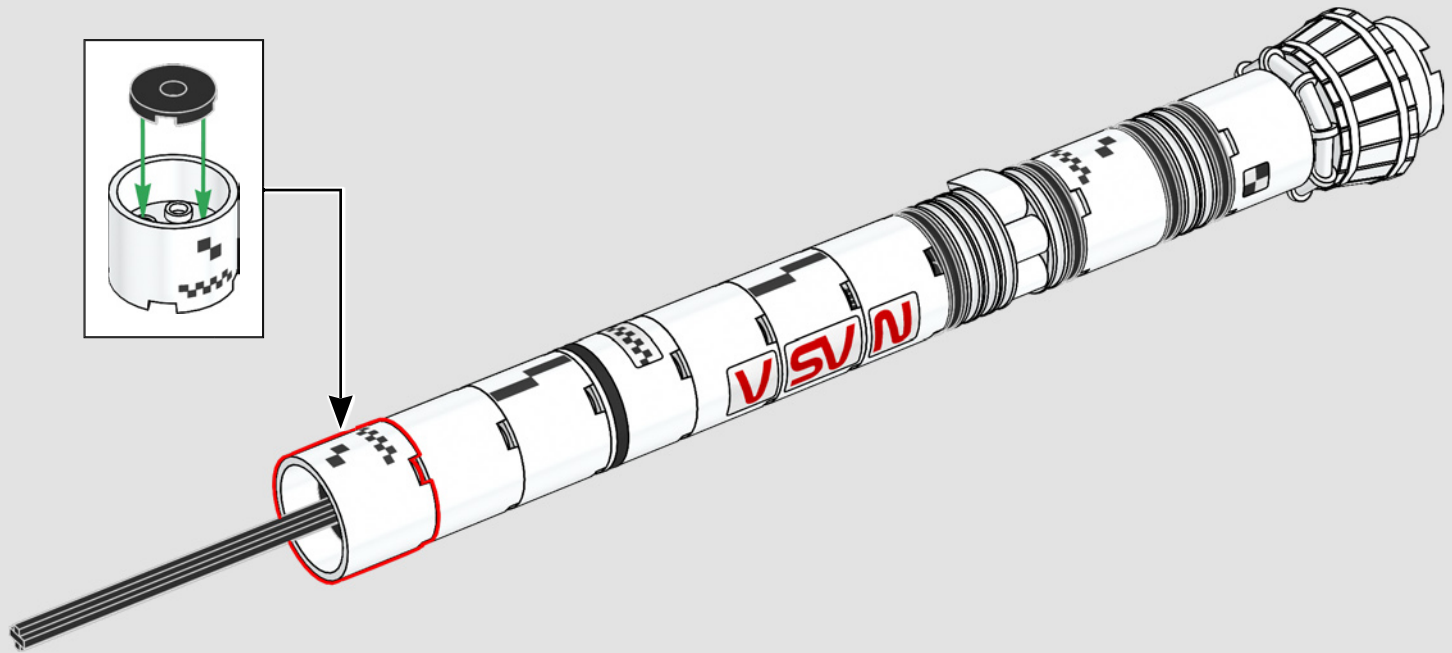
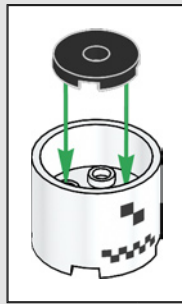

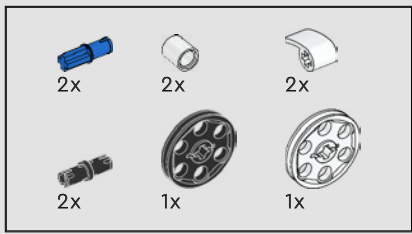

604

1

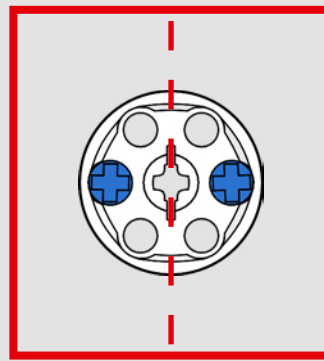
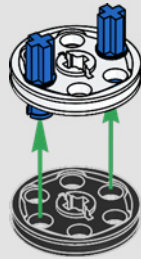

2



3

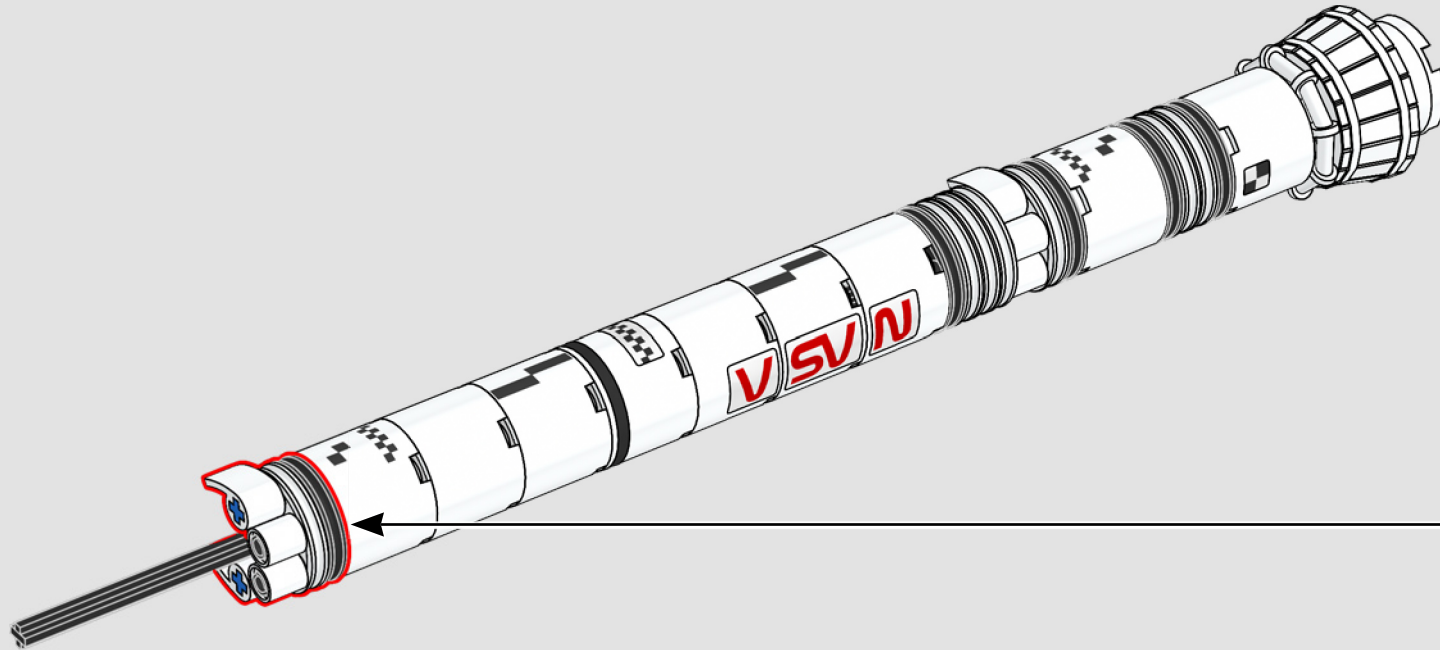



605

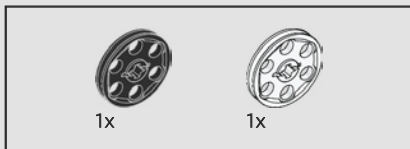
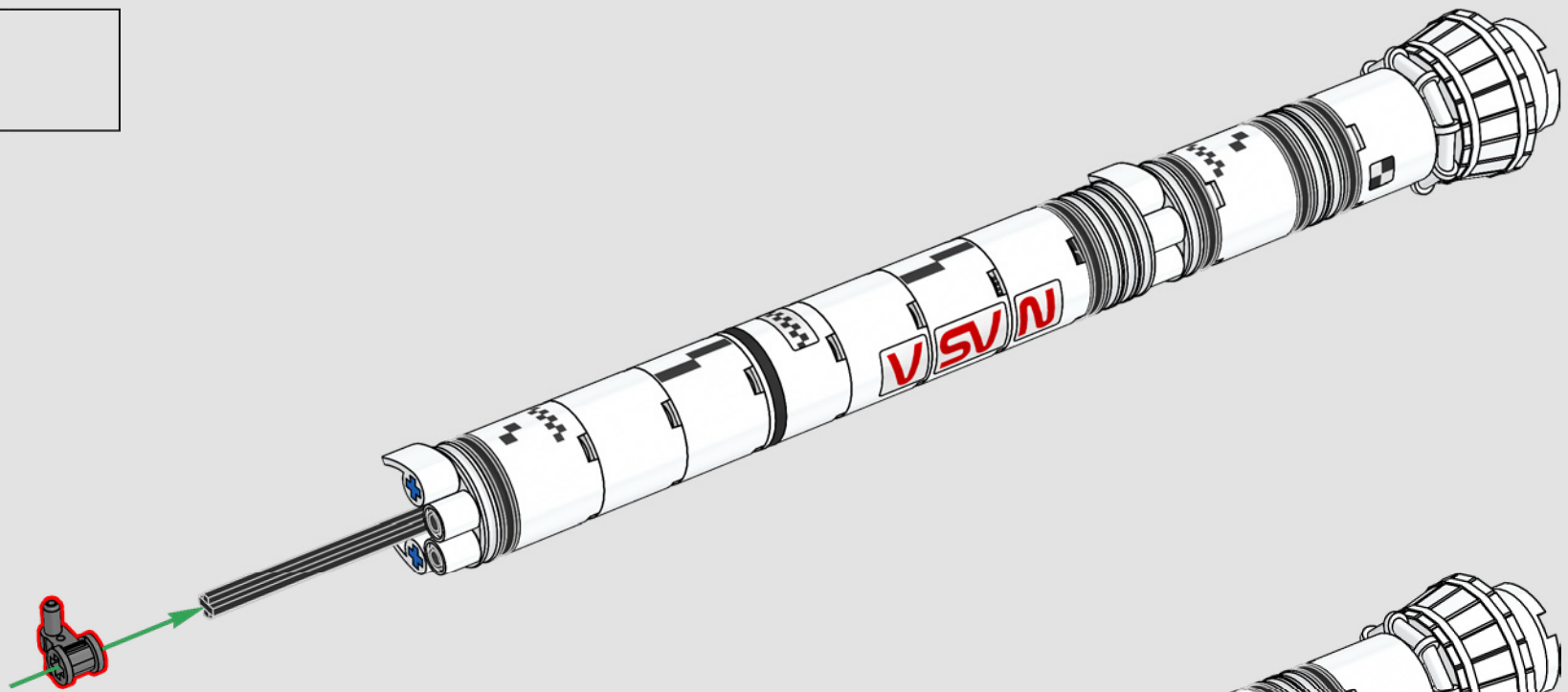

606

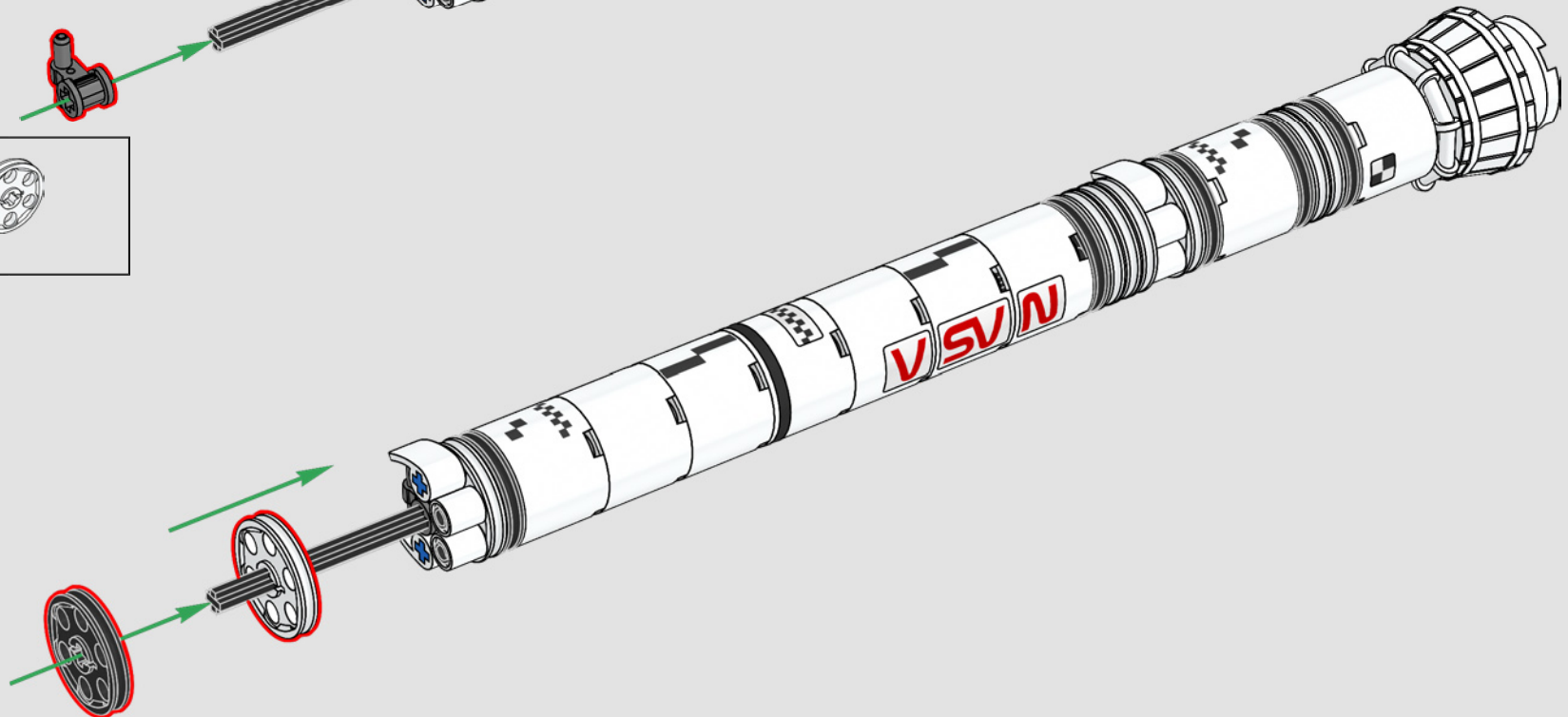

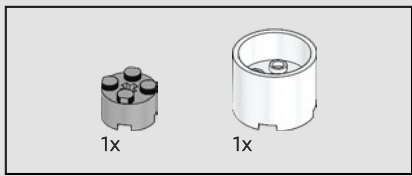

607

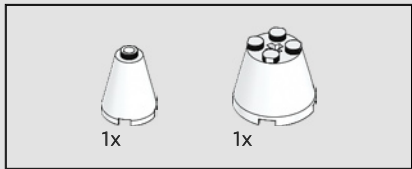
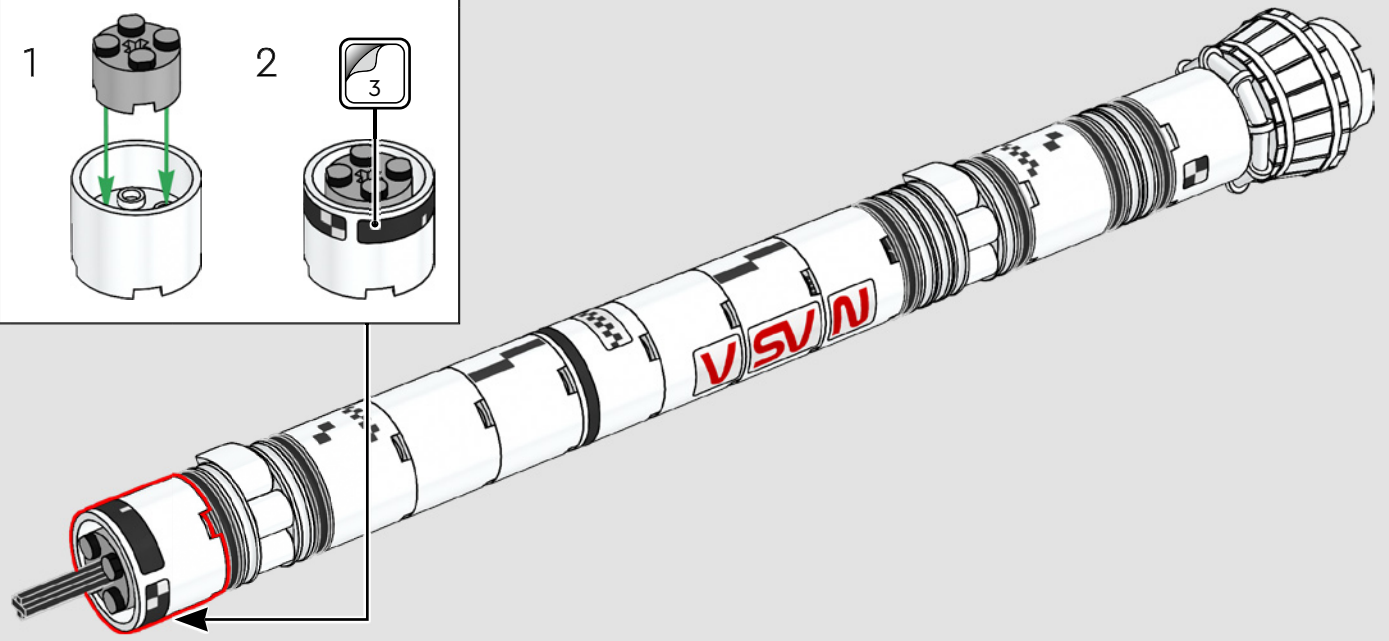
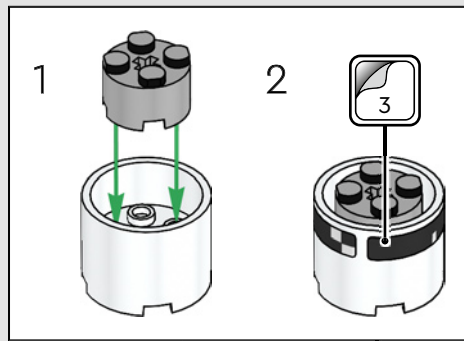

608

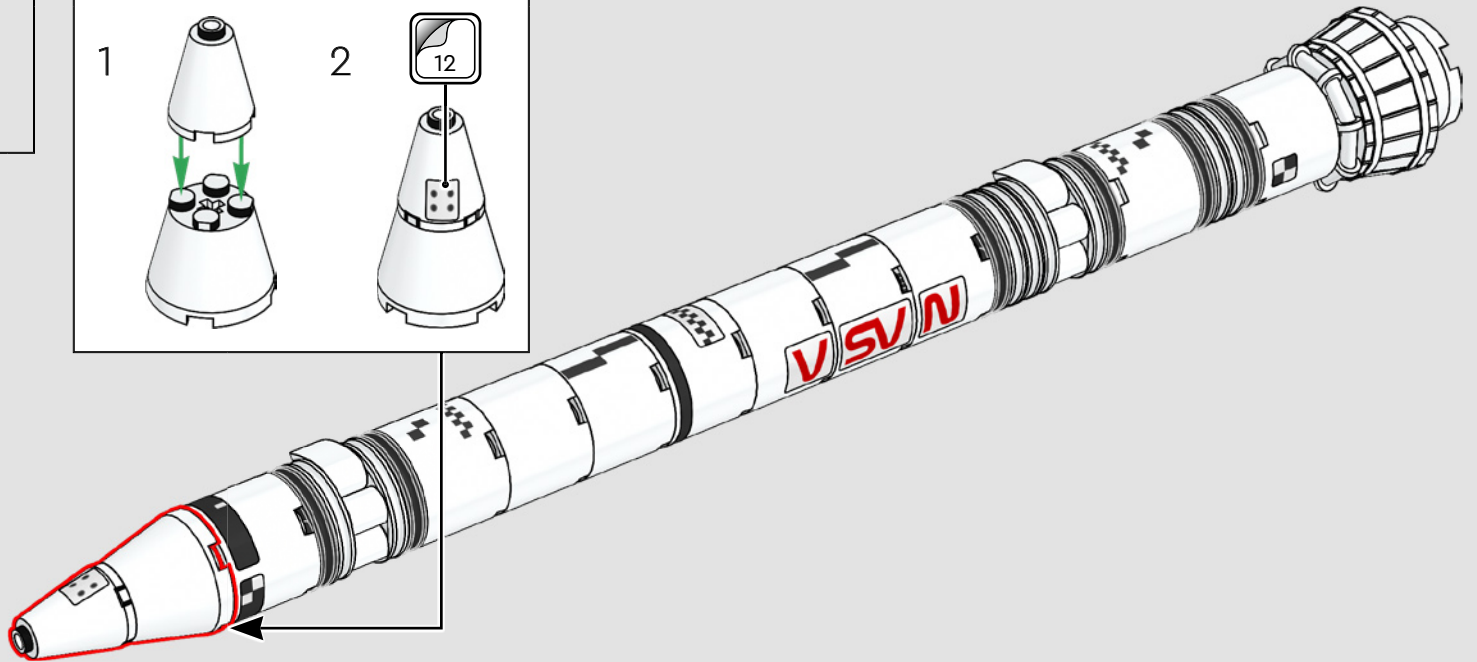
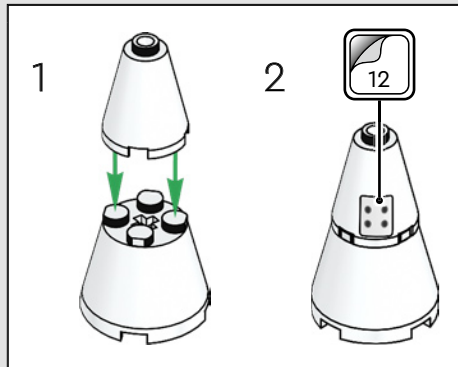

609

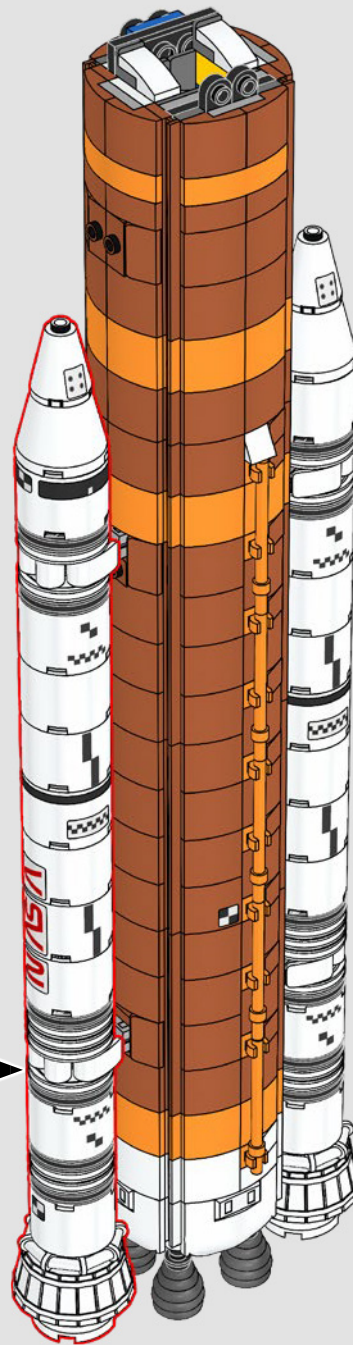

Das kegelförmige Element oben auf den Boostern wurde bereits 1979 für die Raketen aus der Themenwelt LEGO® Classic Space verwendet, hatte damals jedoch eine feste Noppe mit dem LEGO Logo.

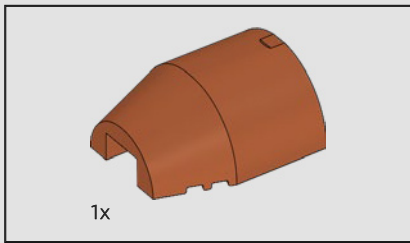

610

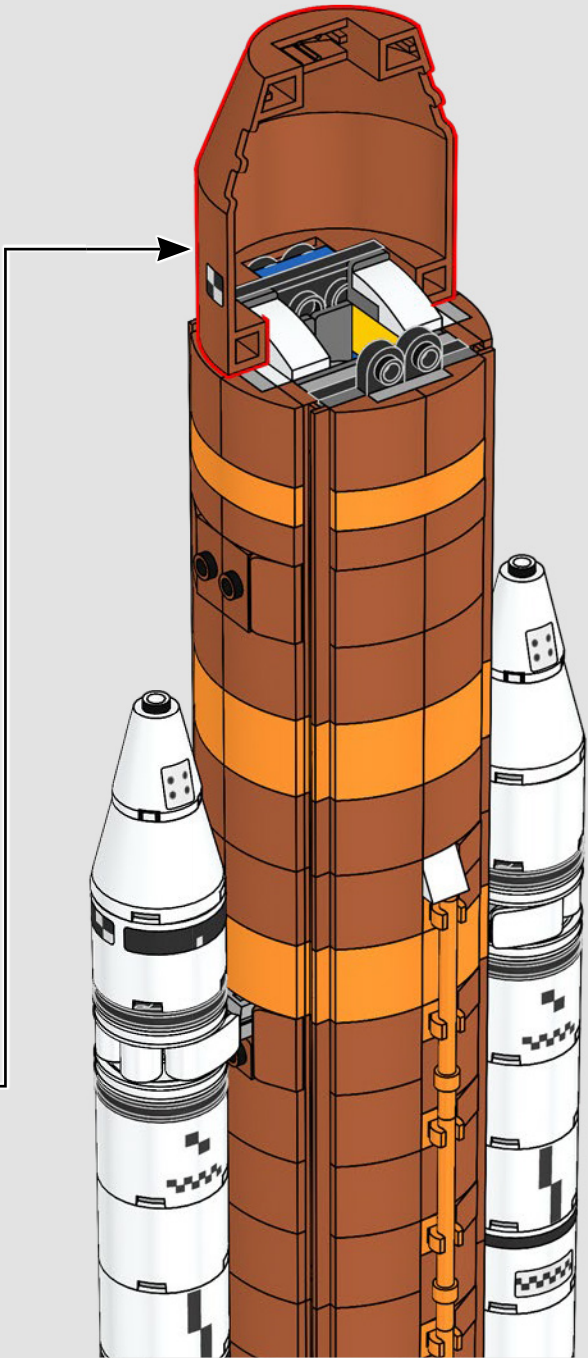
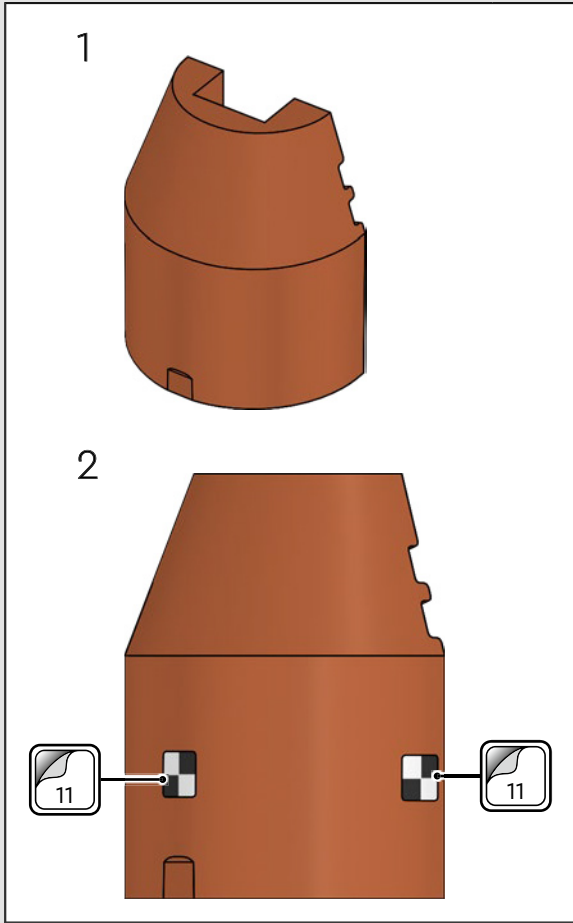

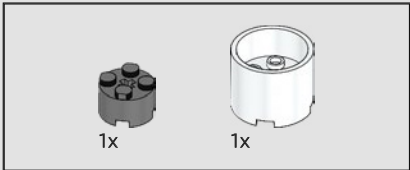
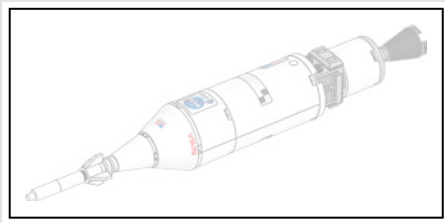

611

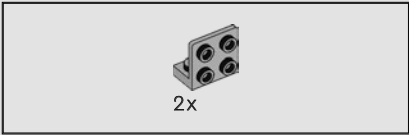
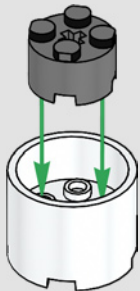

612

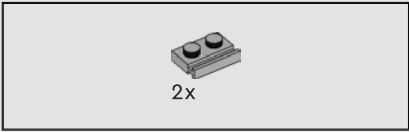
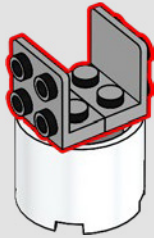

613

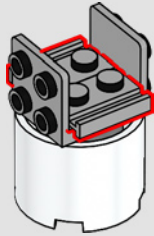

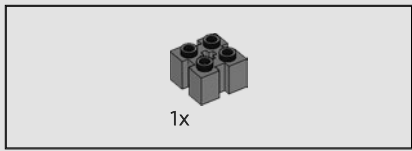

614

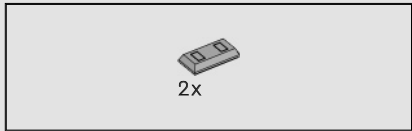
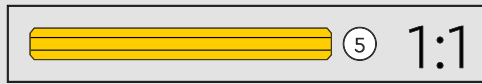
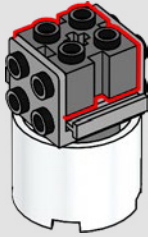

615

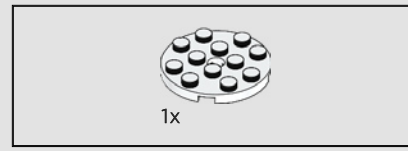
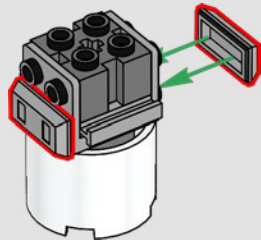

616

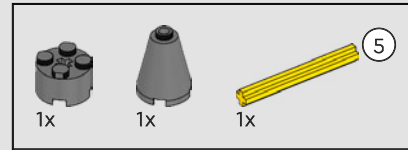
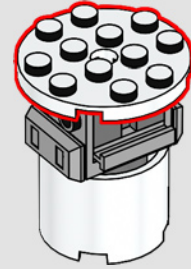

617

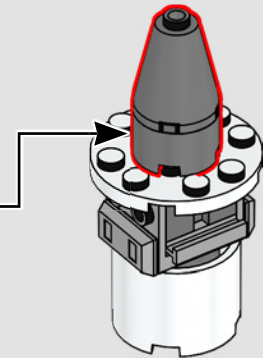
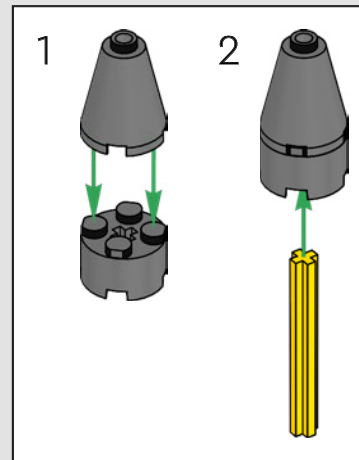

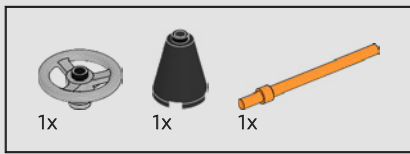

618

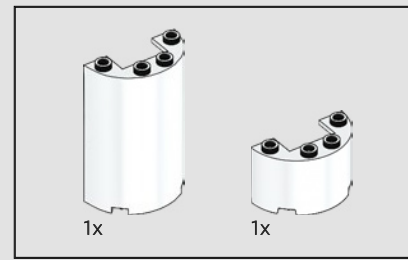
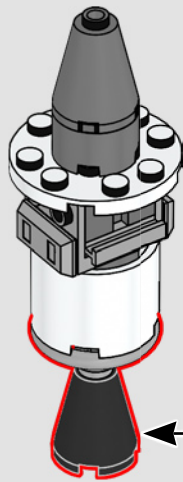
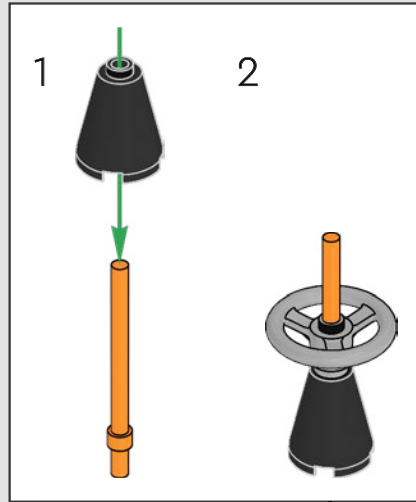

619

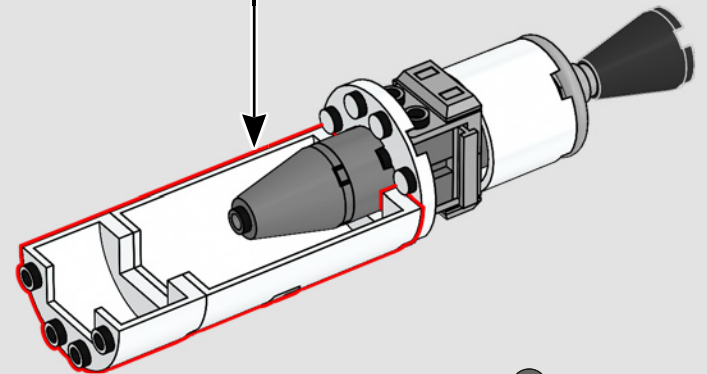
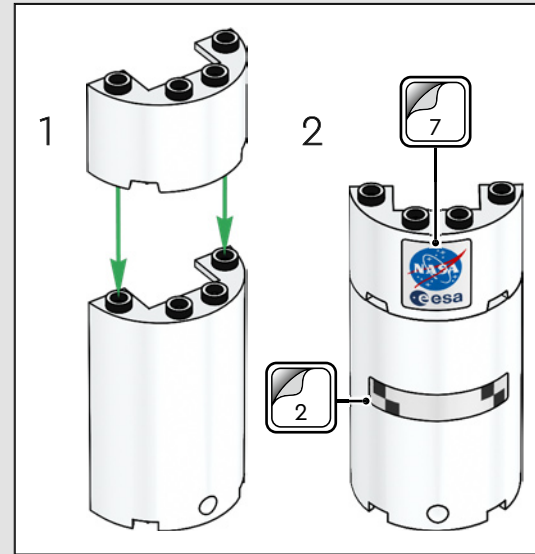

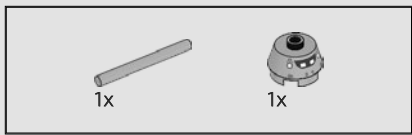

620

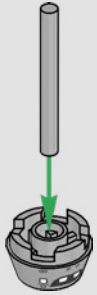

621

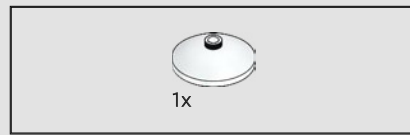
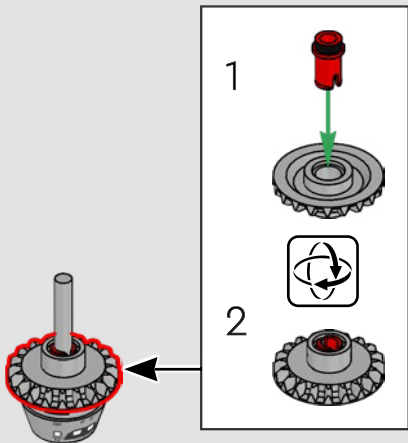

622

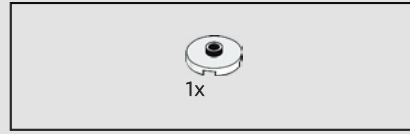
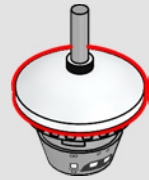

623

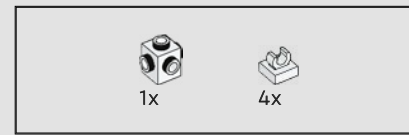
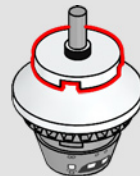

624

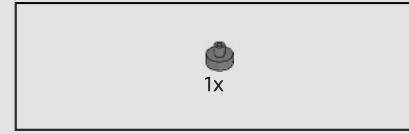
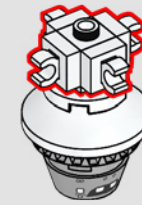

625

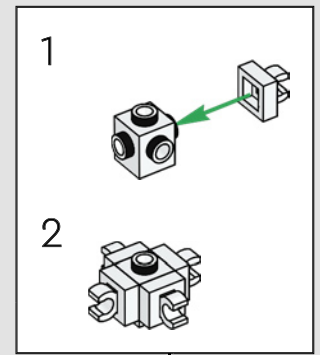
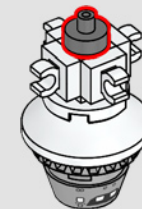

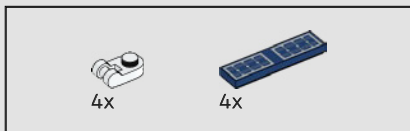

626

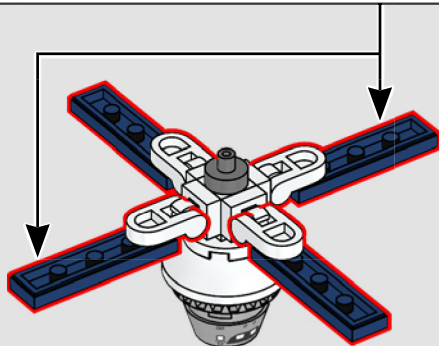
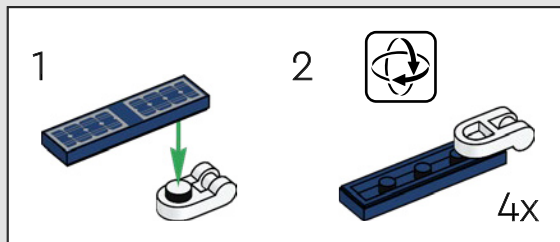

627



628

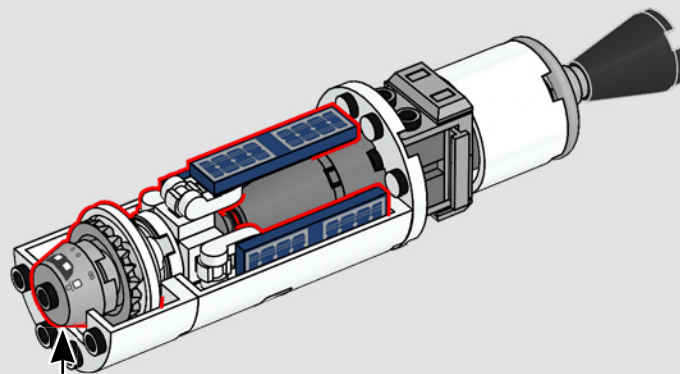

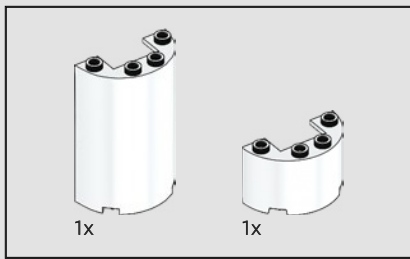

629

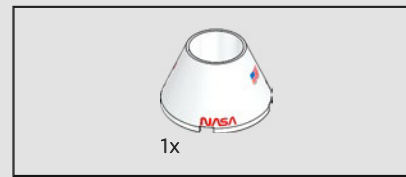
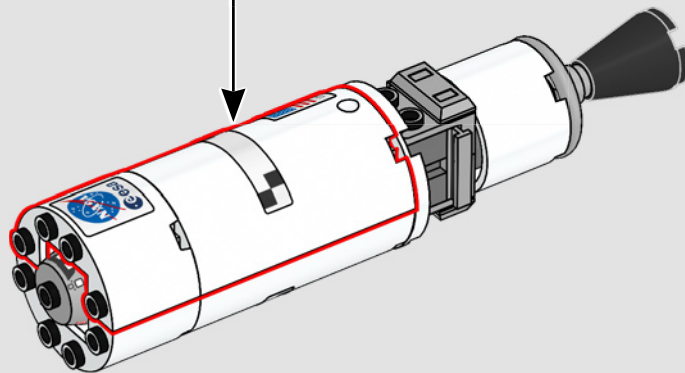
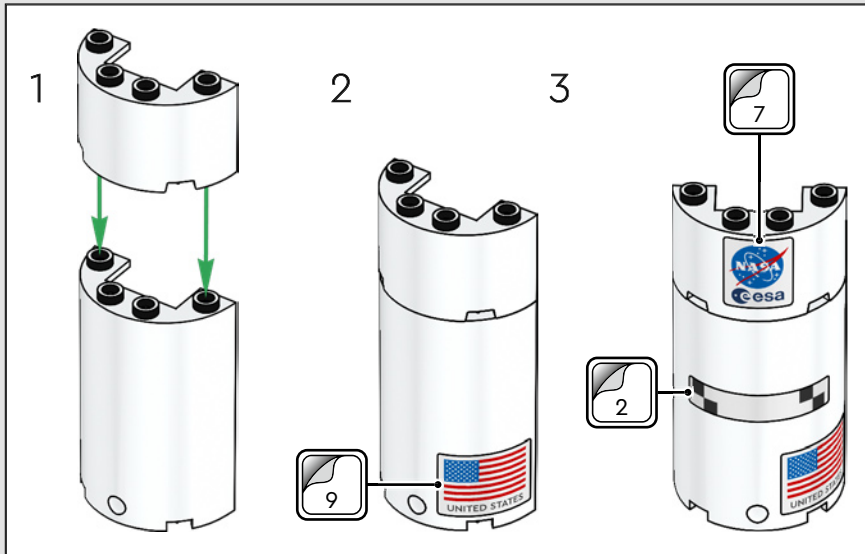

630

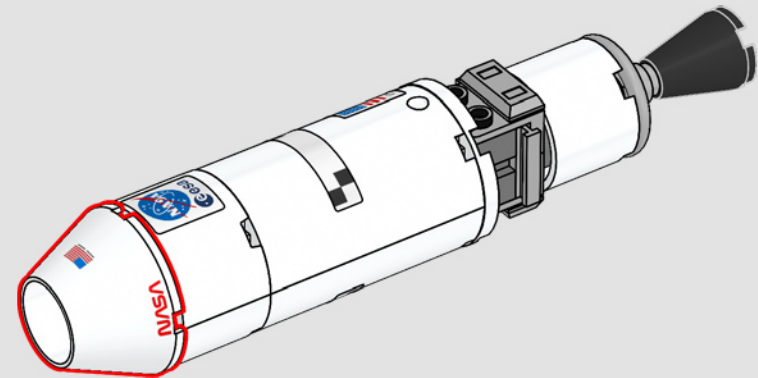

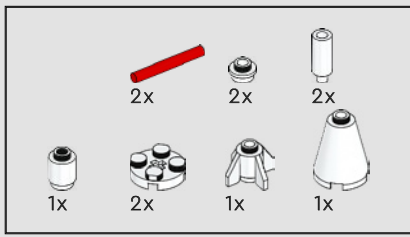

631

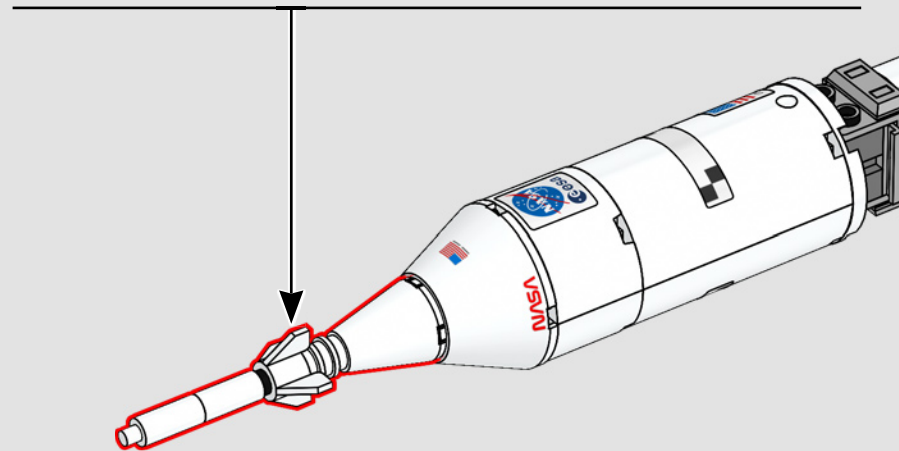
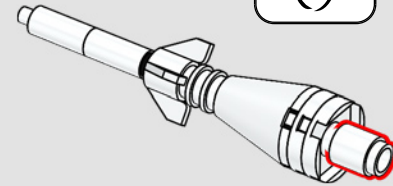
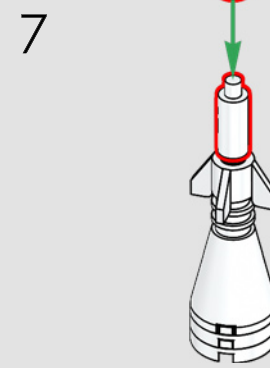
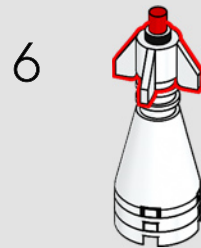
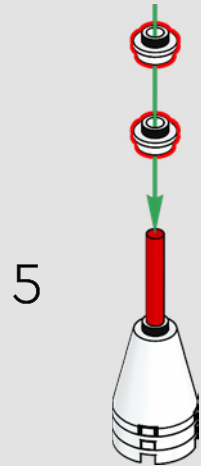
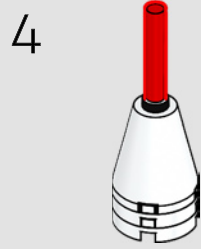
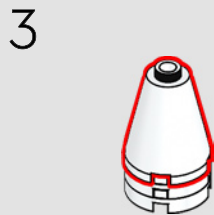
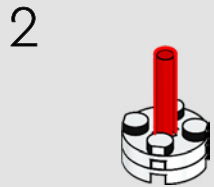
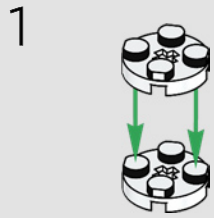

632

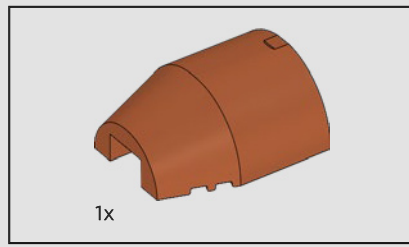
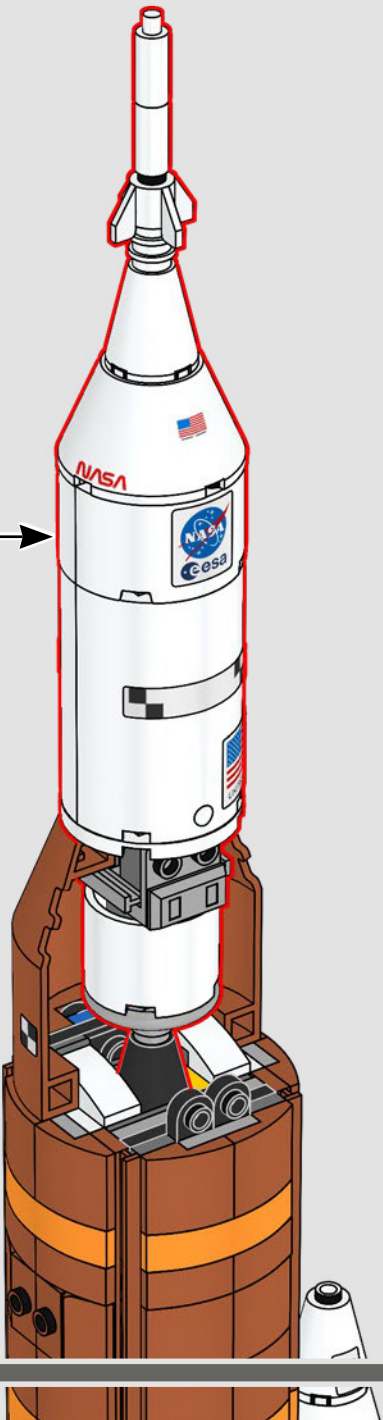

633

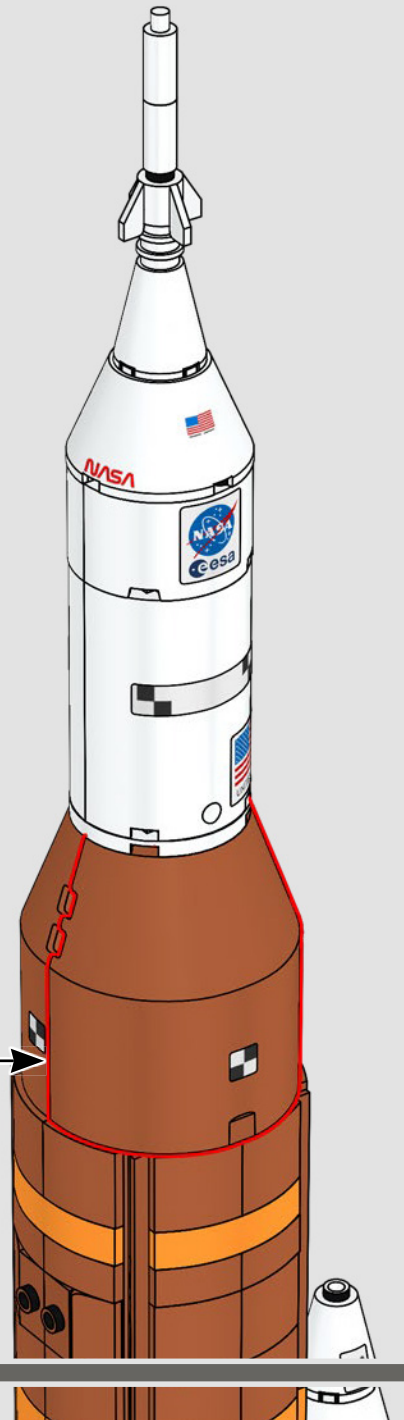
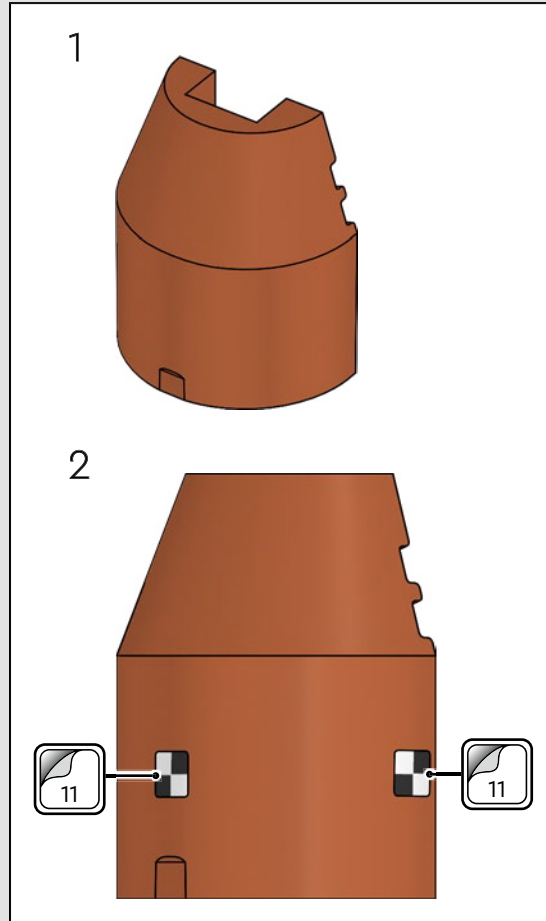

634

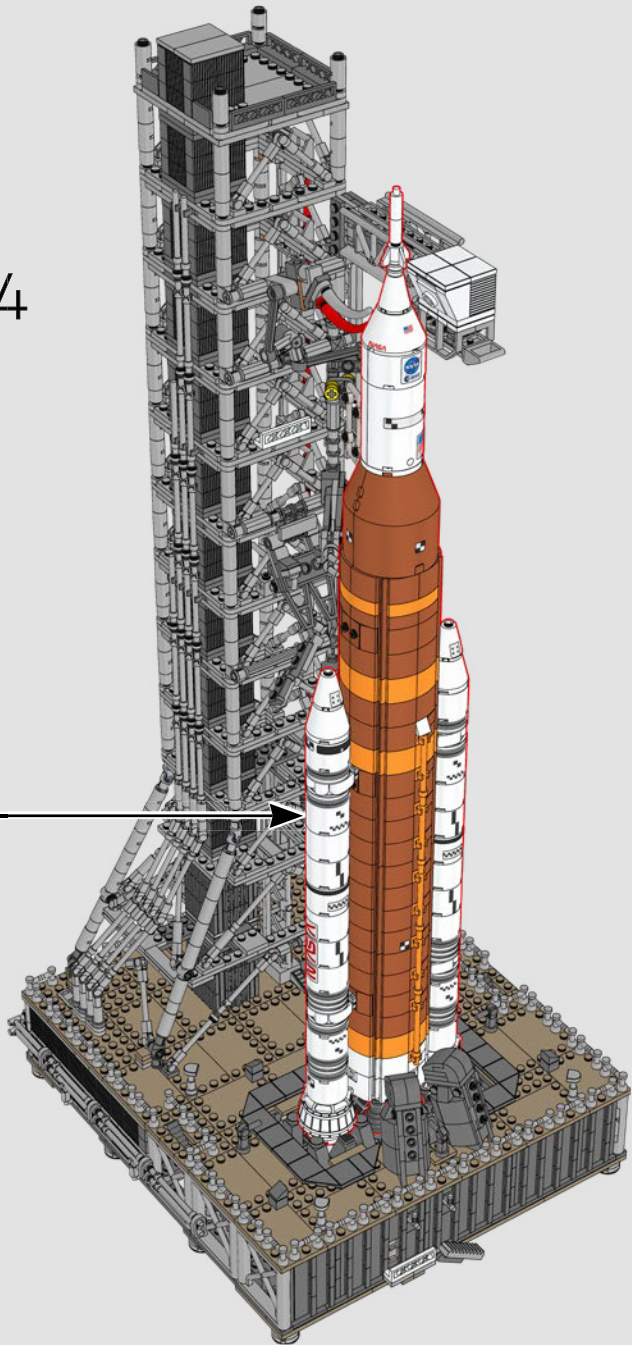

635

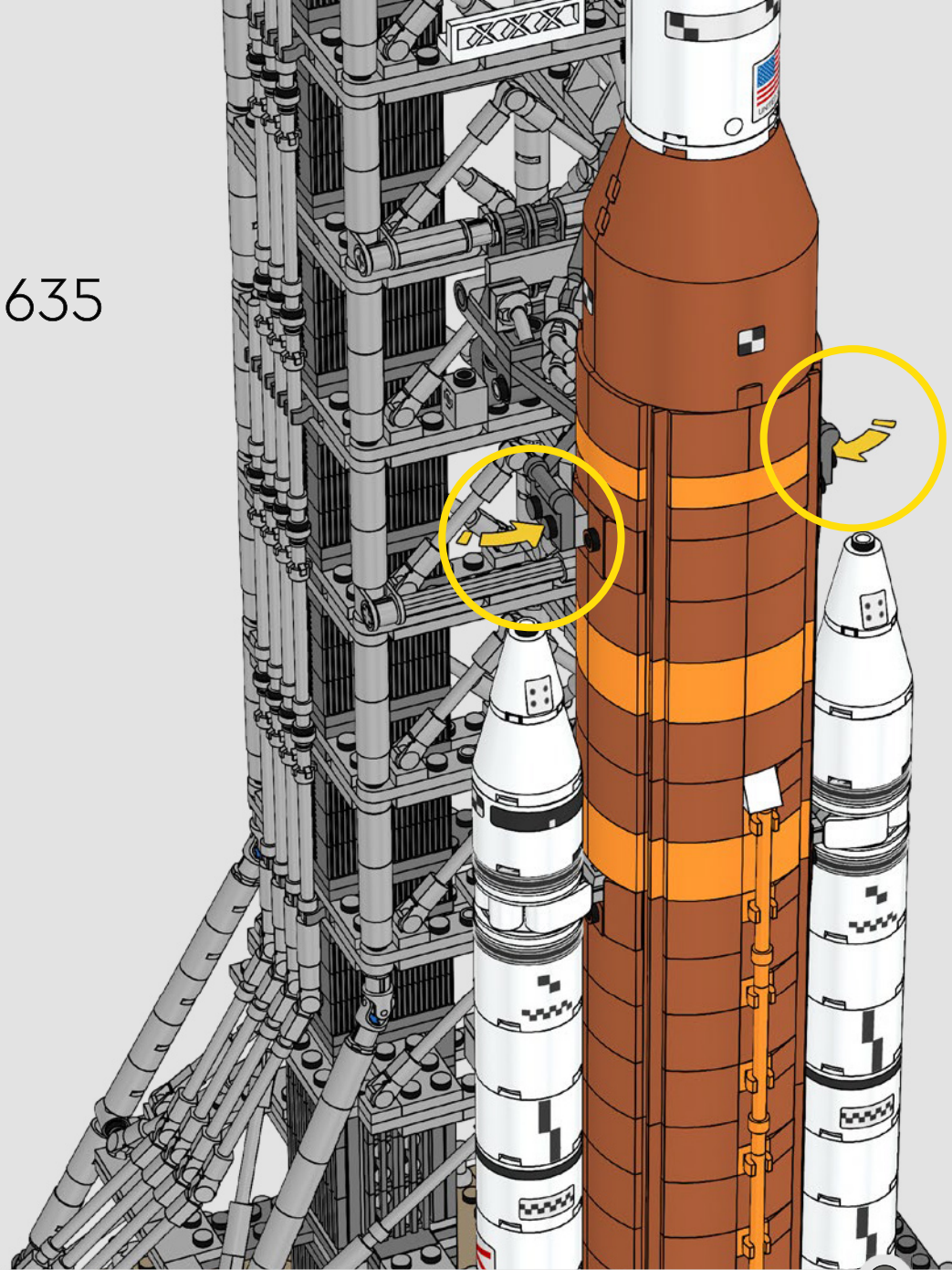

Genau wie beim Original steht die ganze Rakete auf den Schürzen der Booster.

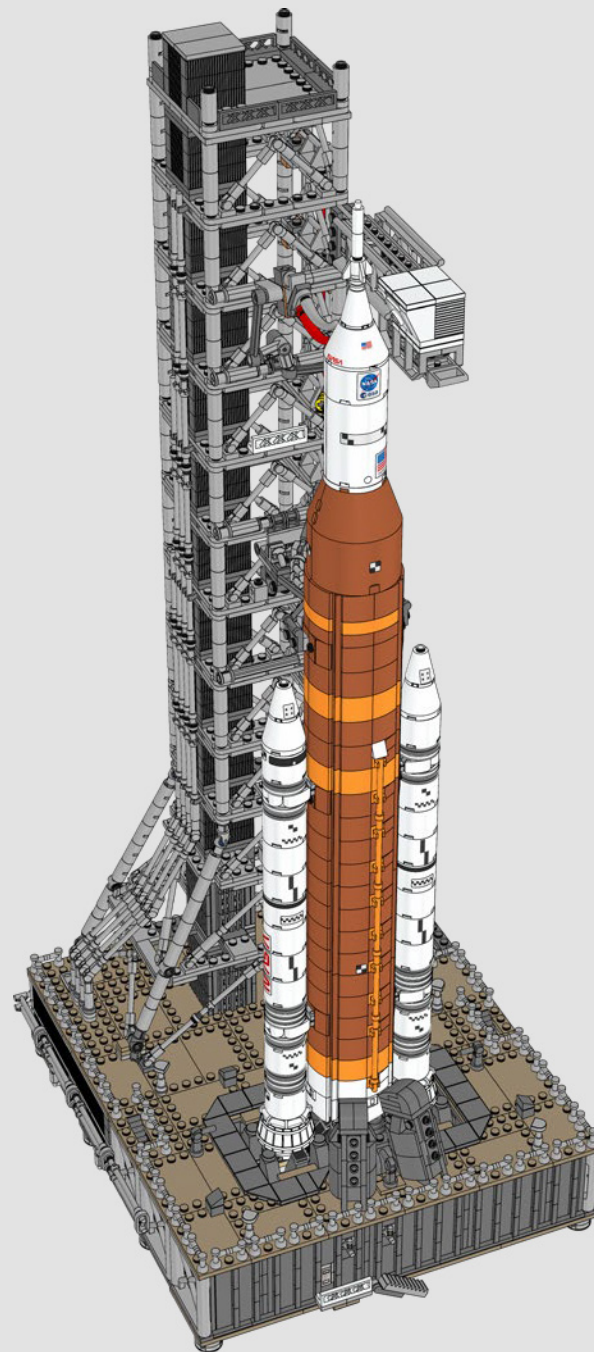

1

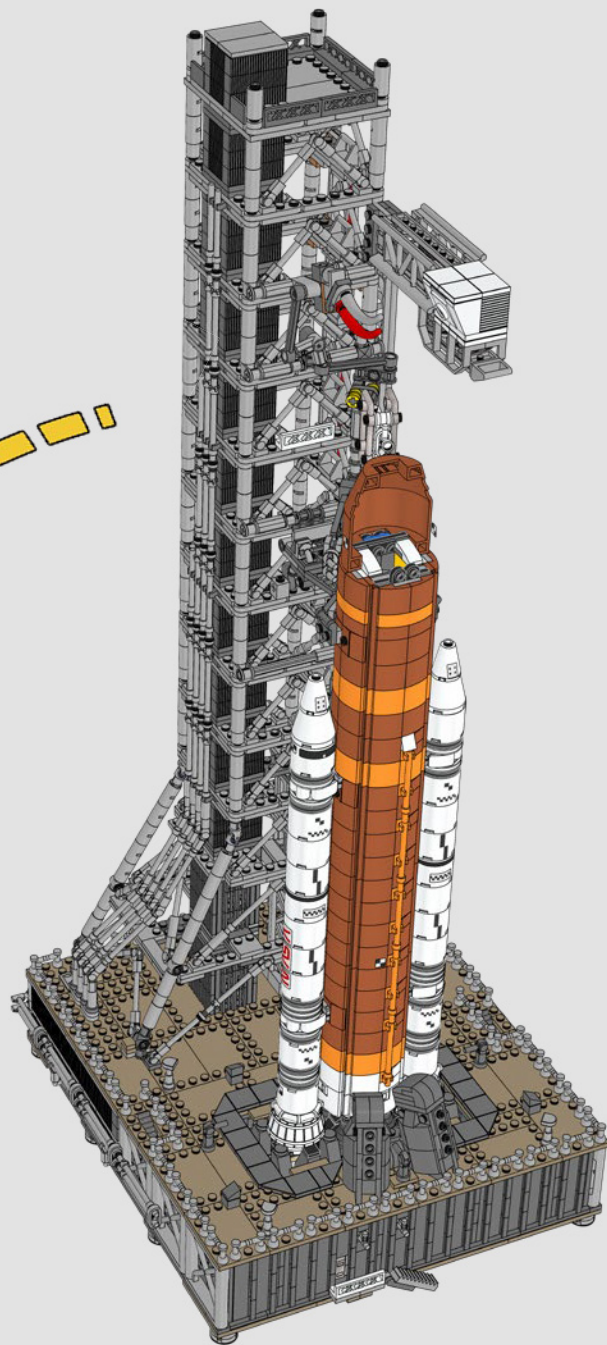
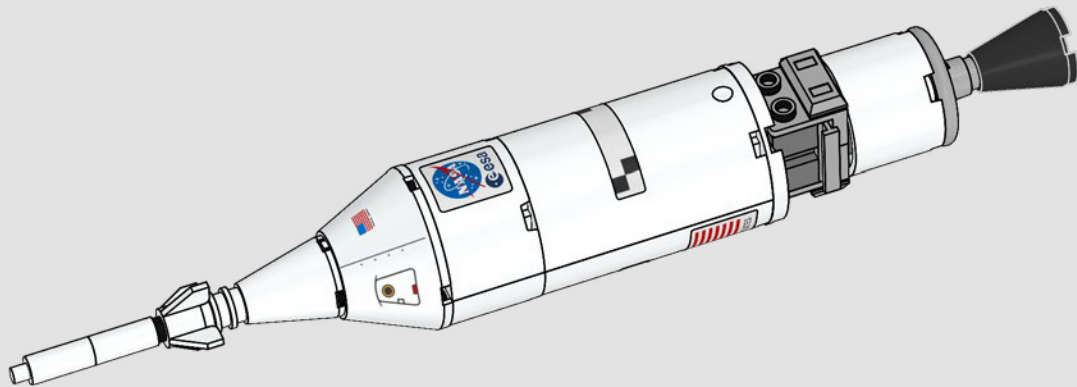
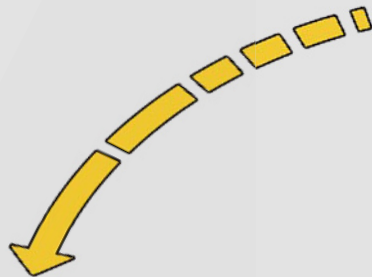
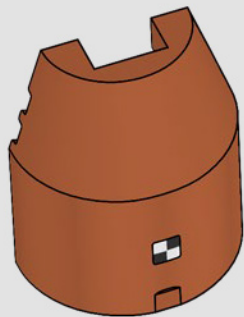

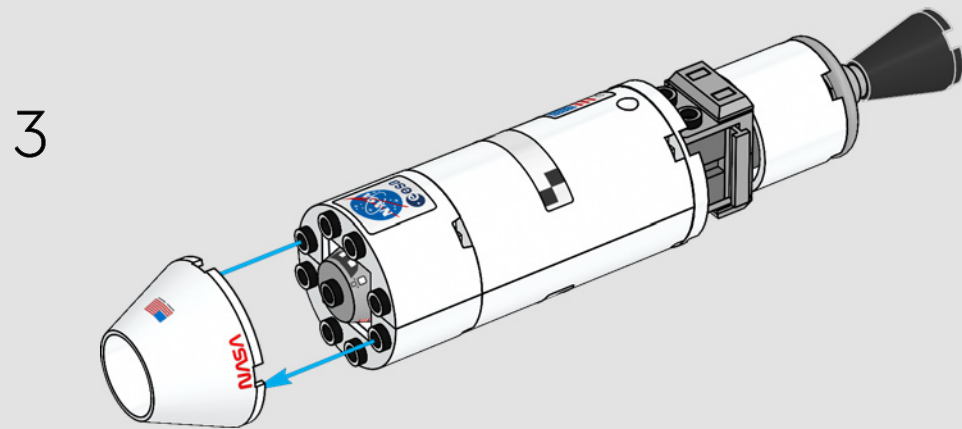
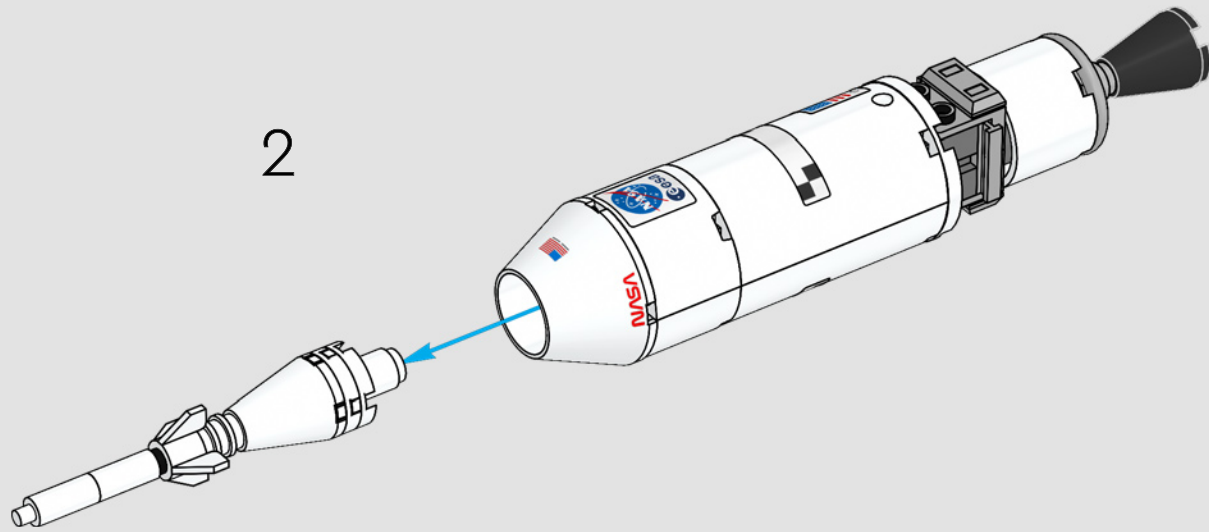

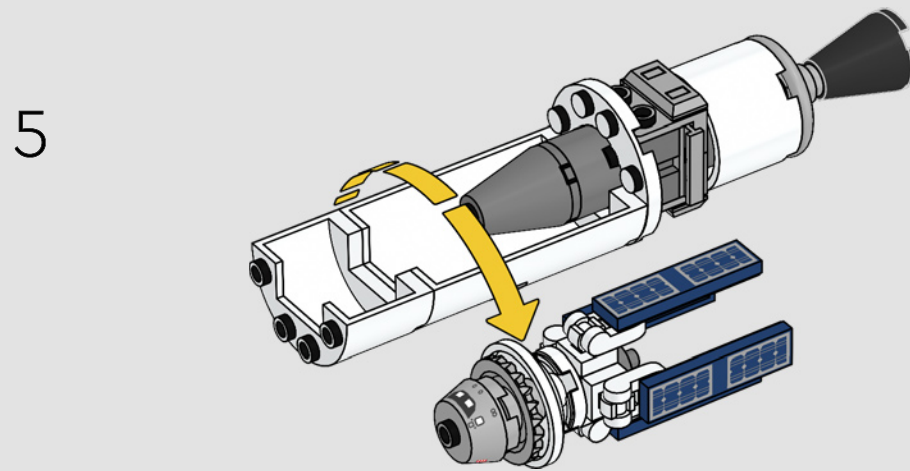
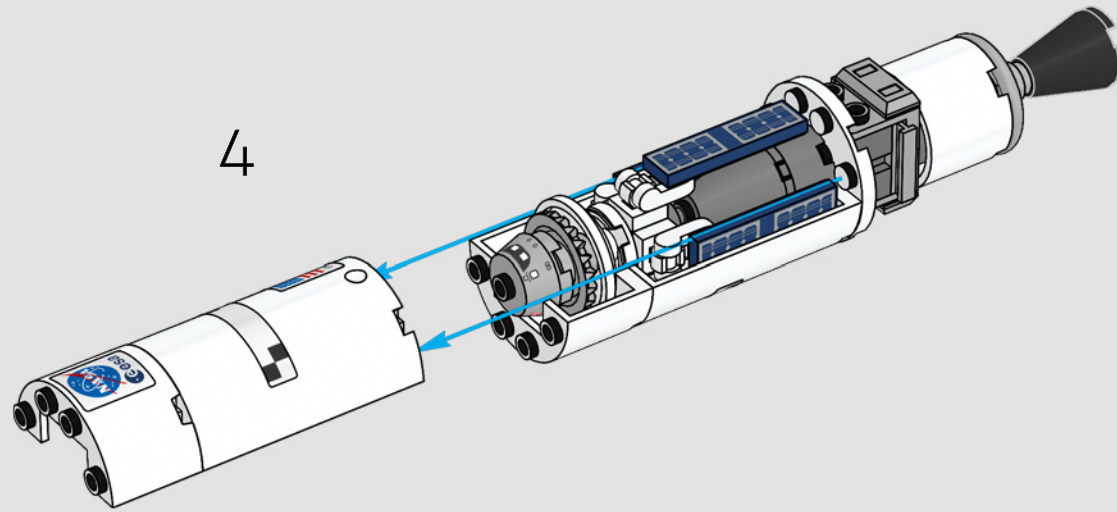

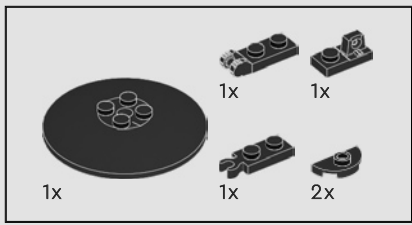

6

1

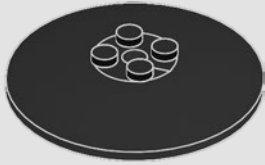

2

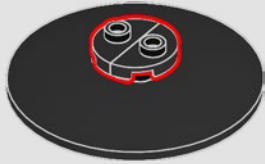

3

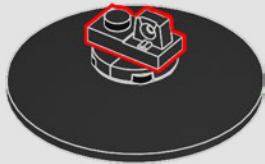

4

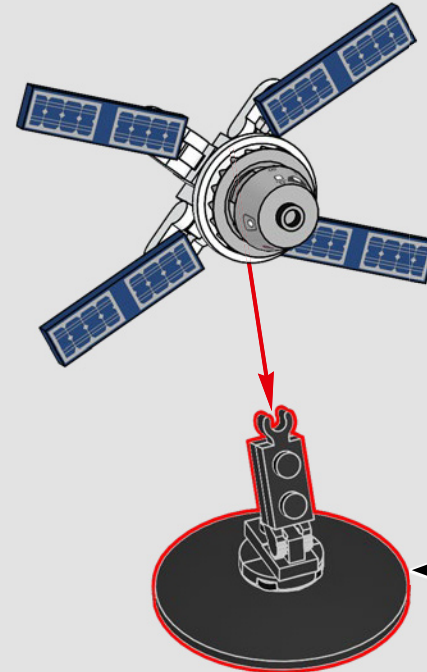
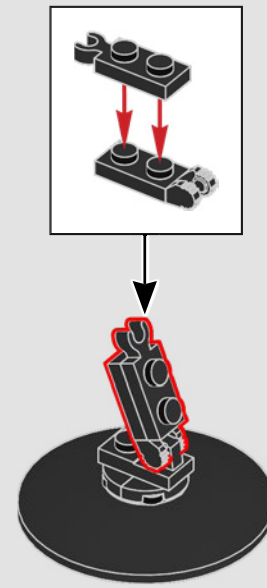

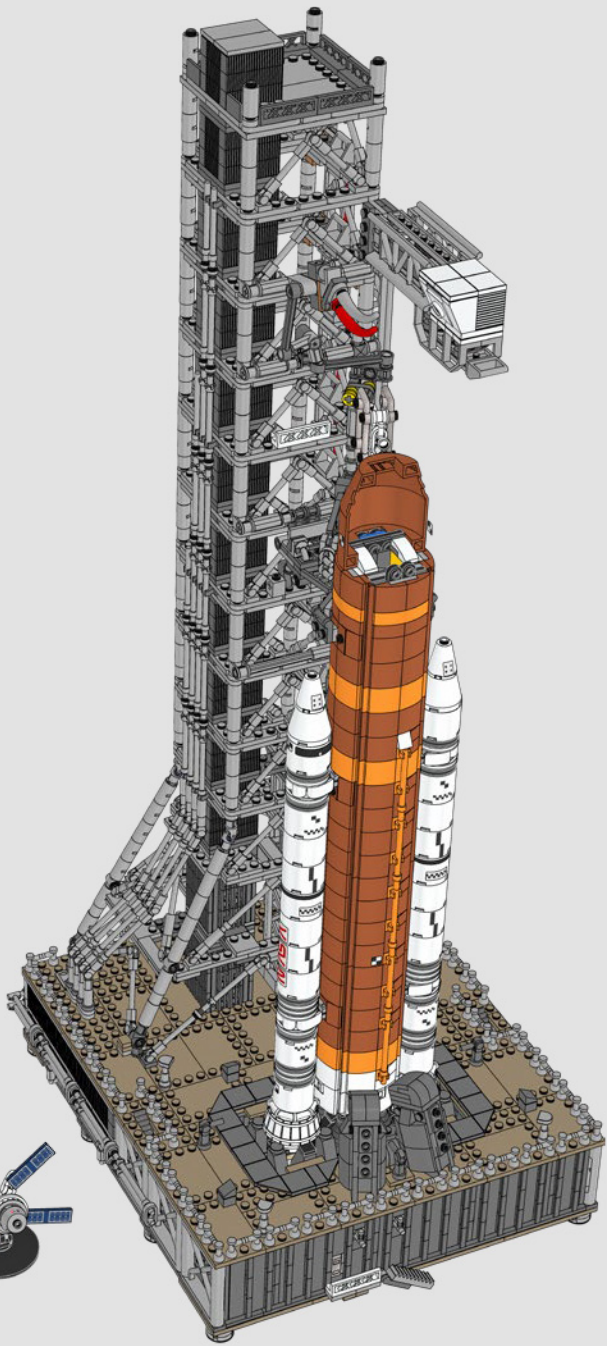

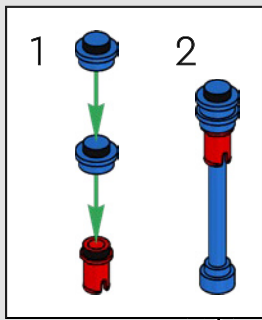
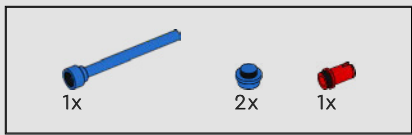

1

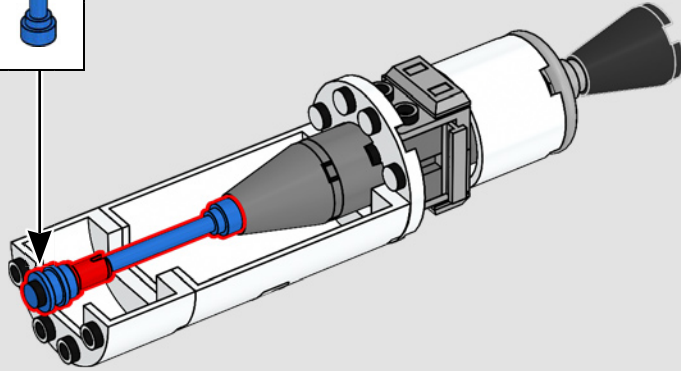

2

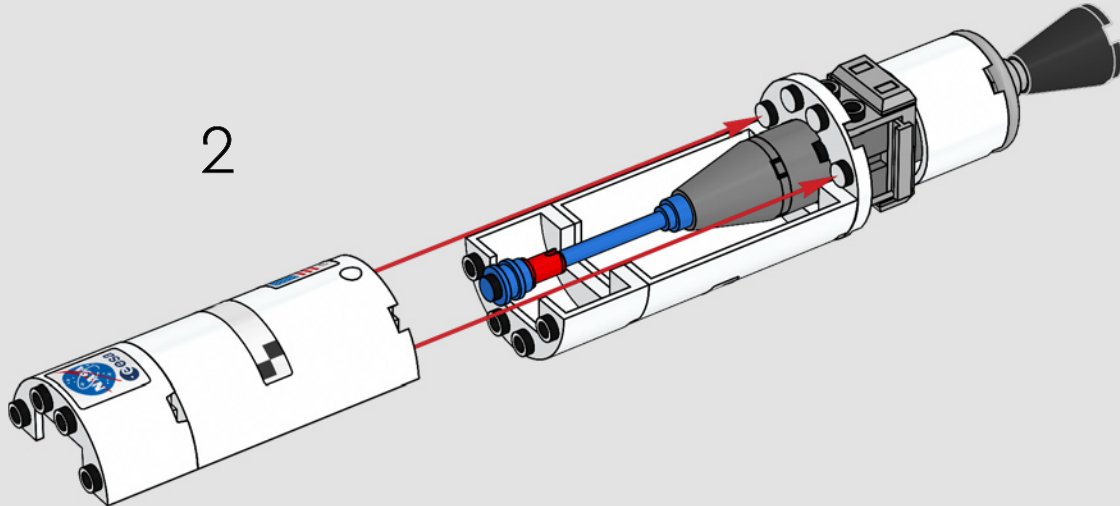

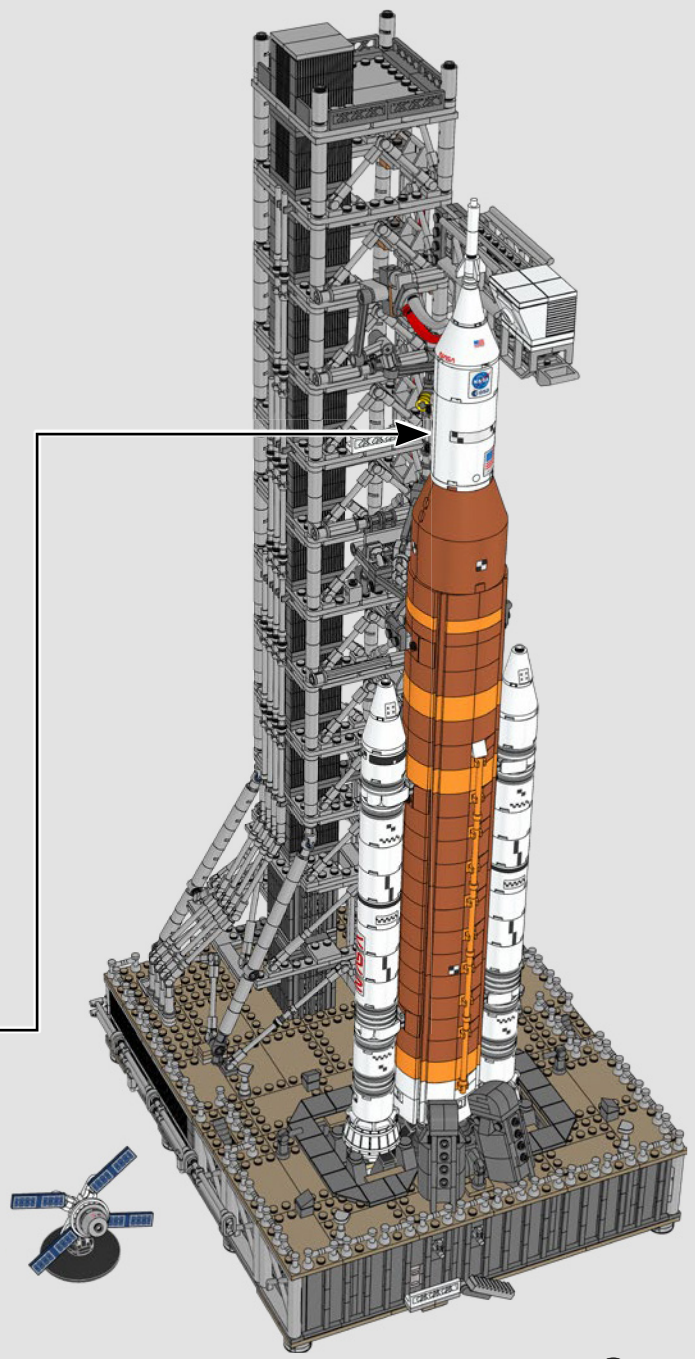
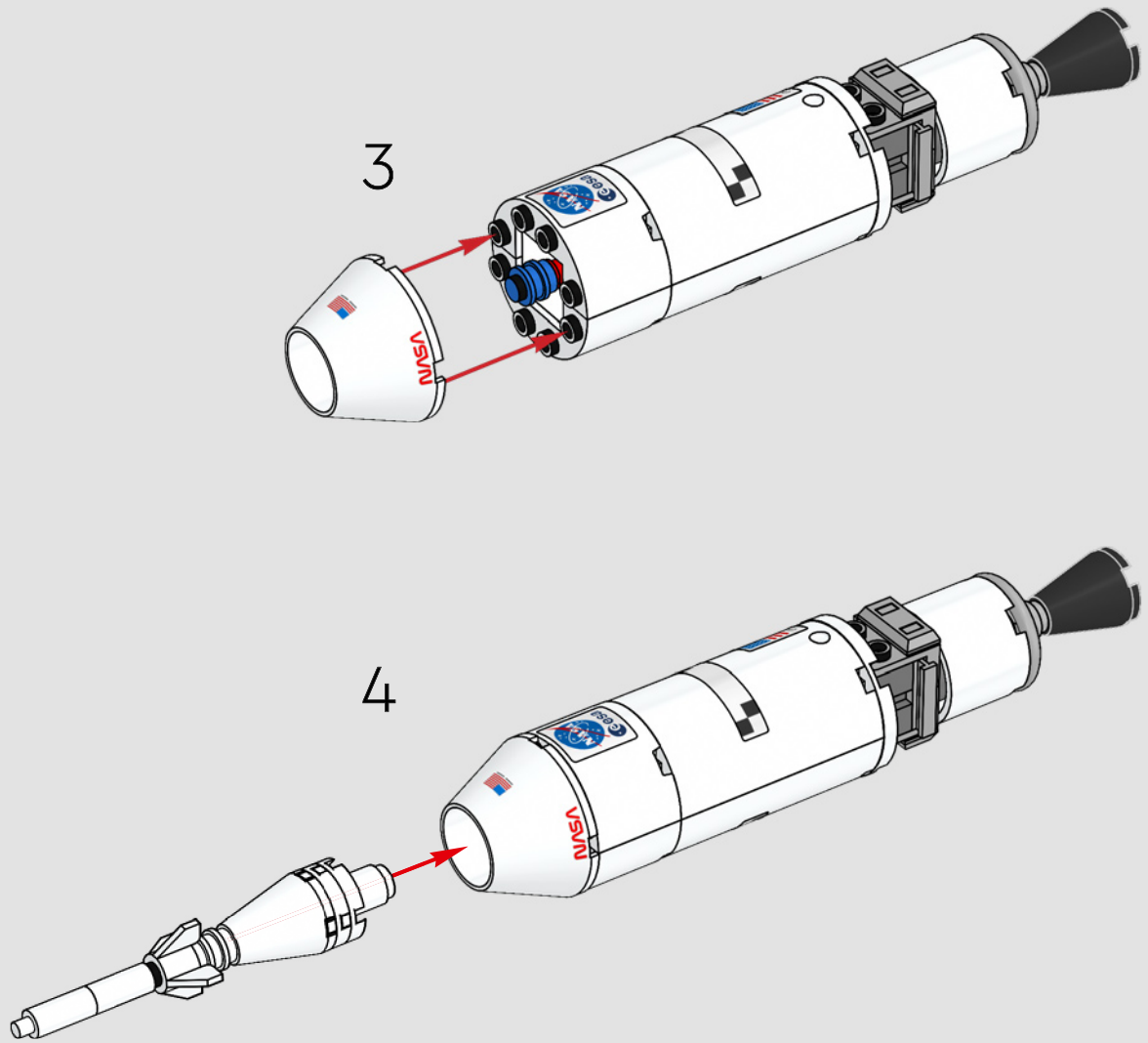

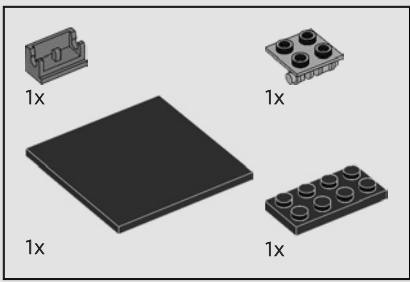

1

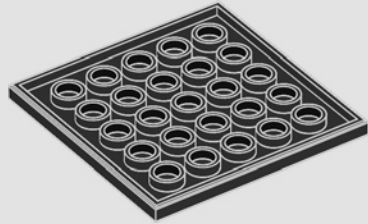

2

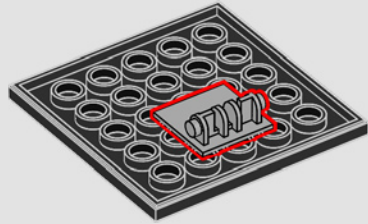

3

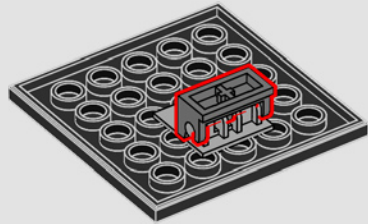

4

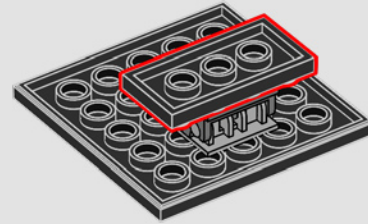

5

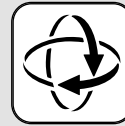
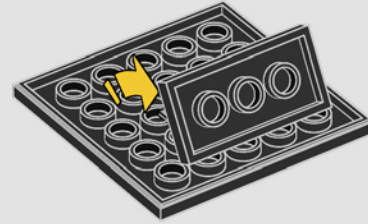

6

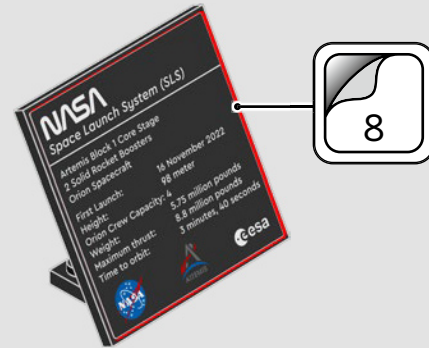

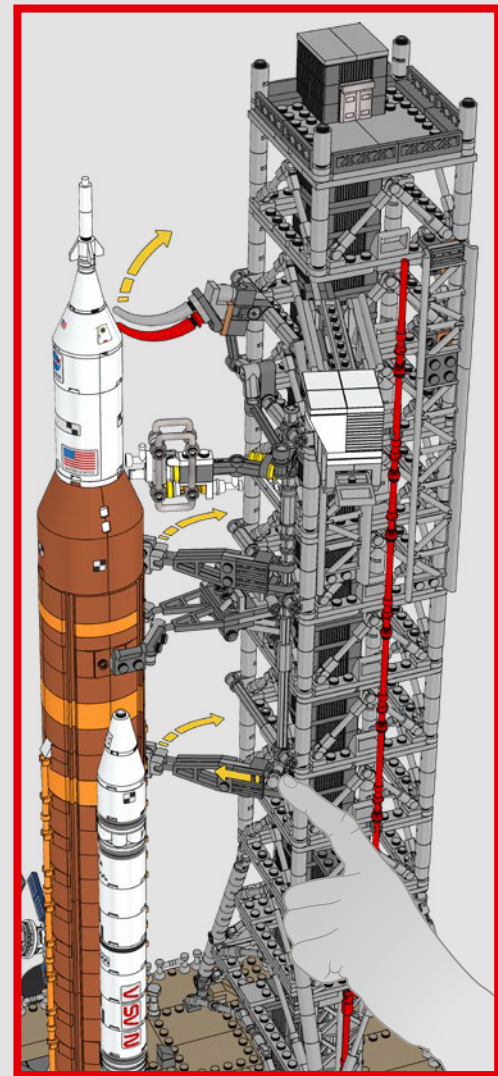
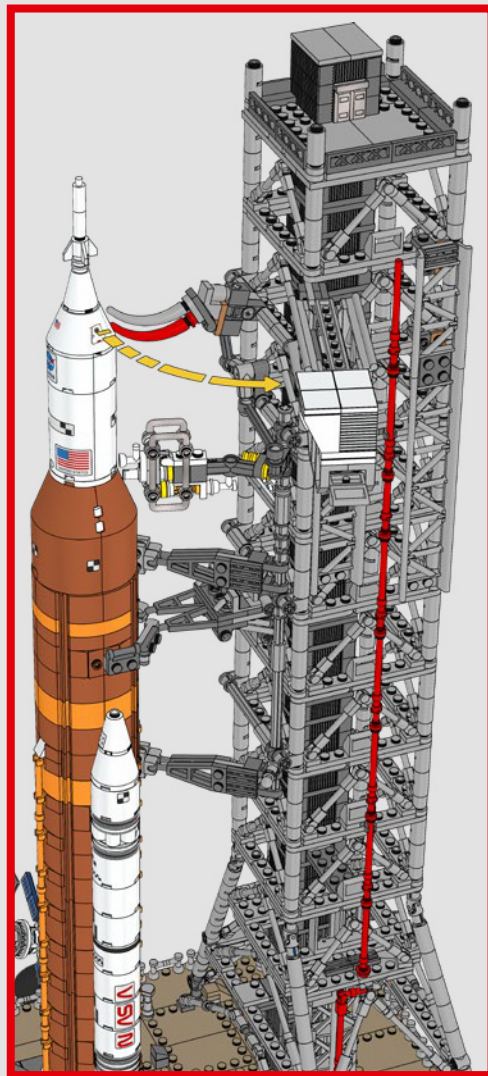
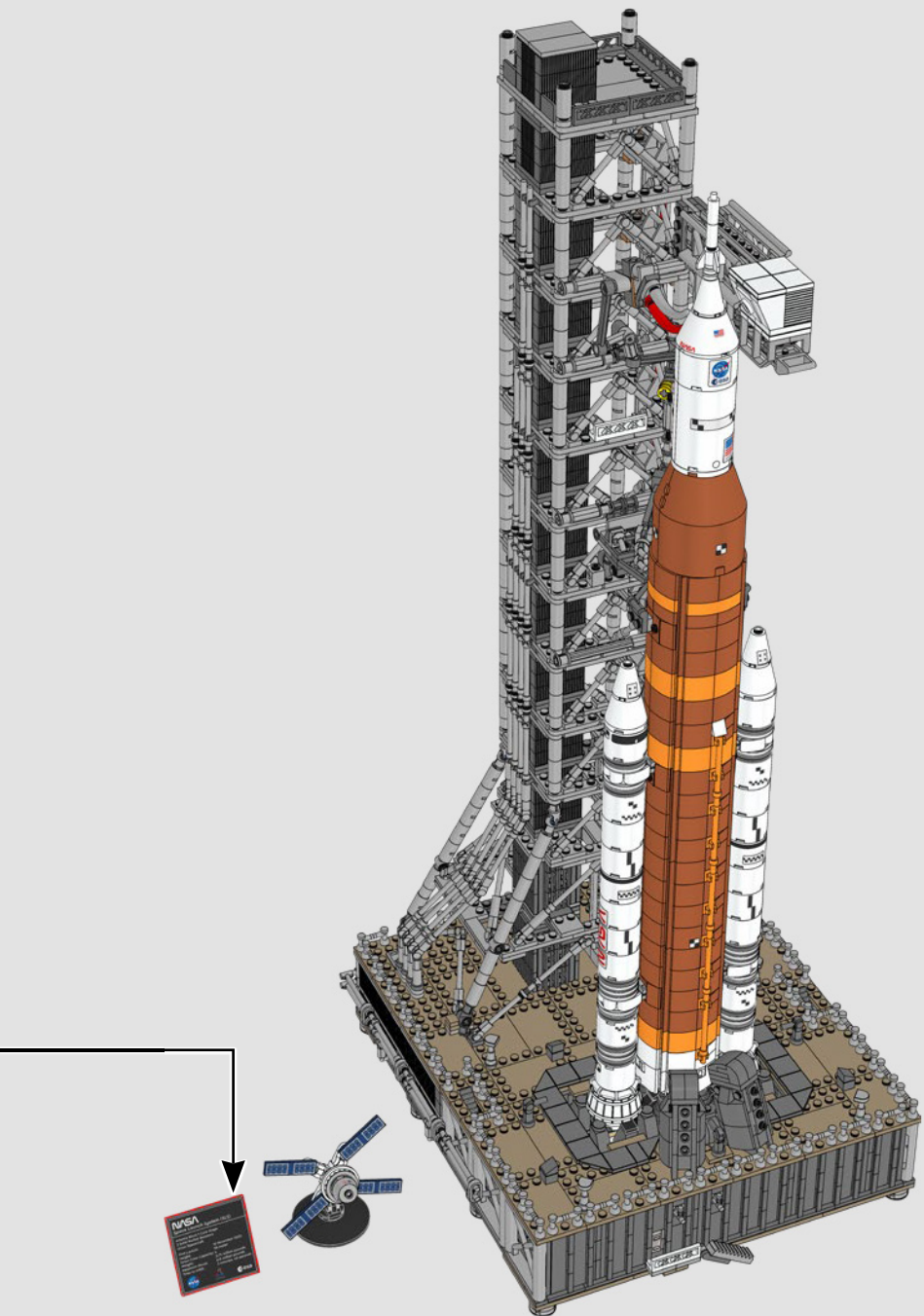

- 2x 6234807
- 7x 614101
- 2x 6168642
- 1x 306201
- 4x 459901
- 1x 6388018
- 11x 6177114
- 2x 300501
- 4x 4504369
- 4x 6348055
- 1x 6442358
- 2x 4111971
- 1x 6331225
- 15x 6210272
- 8x 6434569
- 4x 6174937
- 2x 403201
- 3x 6044601
- 2x 6281990
- 1x 614301
- 1x 6093053
- 5x 6194851
- 5x 287701
- 4x 6173116
- 5x 6210076
- 2x 4515370
- 2x 6166894
- 4x 6034044
- 8x 4249563
- 16x 6330136
- 4x 235701
- 4x 6013866
- 1x 6238334
- 6x 6047220
- 1x 6267044
- 1x 4179580
- 4x 6188466
- 6x 6313593
- 1x 6245249
- 13x 6390507
- 4x 6483019
- 4x 6484829
- 5x 6195371
- 2x 302101
- 2x 6246885
- 2x 6249552
- 2x 6009016
- 2x 4550171
- 1x 4515347
- 1x 6483018
- 4x 6018101
- 2x 6388641
- 2x 4560178
- 5x 4243812
- 17x 379501
- 2x 4113915
- 13x 4114306
- 2x 4121921
- 8x 4118790
- 2x 6223291
- 9x 4166138
- 2x 4249019
- 2x 6093864
- 2x 6330584
- 8x 6231857
- 1x 6341972
- 1x 306221
- 2x 6223427
- 2x 459921
- 4x 6378120
- 2x 6210269
- 1x 6399645
- 2x 4142865
- 5x 302321
- 4x 241221
- 3x 6275080
- 2x 300321
- 12x 300221
- 1x 6129995
- 1x 6431120
- 2x 300121
- 9x 6170487
- 1x 6253828
- 10x 4181138
- 1x 6130004
- 1x 416221
- 1x 383221
- 2x 614123
- 26x 4206482
- 7x 302323
- 10x 6092582
- 32x 6345634
- 5x 6299413
- 2x 6469450
- 1x 302123
- 1x 4166140
- 2x 300123
- 3x 302023
- 2x 6210271
- 2x 302328
- 20x 6104342
- 12x 6188477
- 4x 6092602
- 4x 4570877
- 8x 6186009
- 2x 6440767
- 8x 6228839
- 114x 6104344
- 2x 6394948
- 1x 6219673
- 16x 6472959
- 2x 6381453
- 17x 6240030
- 3x 6271167
- 2x 6284577
- 6x 6119197
- 2x 302324
- 14x 4164073
- 1x 6130008
- 11x 6329869
- 2x 383224
- 4x 6168646
- 4x 307026
- 4x 4504382
- 1x 6344752
- 2x 6438919
- 4x 6371584
- 5x 6024730
- 1x 4653822
- 114x 6279875
- 4x 4109810
- 1x 6092664
- 6x 6143850
- 2x 4253815
- 32x 6092585
- 4x 4121966
- 1x 393826
- 1x 6338799
- 1x 6350725
- 12x 6323668
- 4x 6267045
- 4x 6428167
- 1x 6116604
- 1x 243126
- 12x 6174917
- 1x 302026

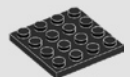

12x
4243819

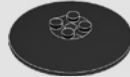

1x
6058341



3x
4181144



4x
373826

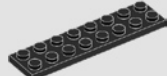

2x
303426

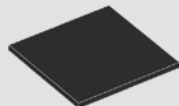

1x
6155125



5x
6001494

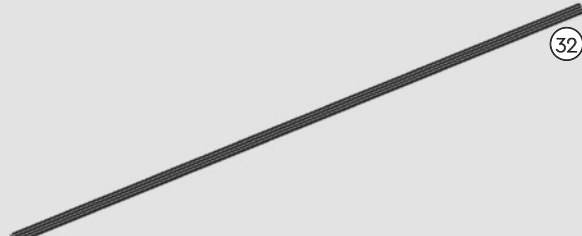

2x
6210821



20x
6472962



8x
4121739



12x
6021787



24x
6067913



4x
4650977



11x
6472965



1x
6240515



8x
4528604



2x
6092591



8x
6335228



2x
6396392



2x
6047415



2x
4550168



4x
6015452



2x
6328307



2x
6257599

32



11x
4267874



2x
4550329



28x
6472958



6x
6006524



6x
4251796



4x
6215341



1x
6134252



48x
6170418



16x
6436421



34x
4539481



36x
6347715



56x
6355025



1x
6355025



128x
6343976



2x
6271165



1x
4211412



5x
6258831



8x
6439041



10x
6326748



5x
6250597



9x
6275844



4x
6321303



88x
4211503



33x
6183784



2x
4211483



5x
4211535



4x
4211476



60x
6308012



6x
4211399



2x
6336539



2x
4211389



2x
6362975



2x
6345639



2x
4213567



4x
6443149



26x
6248890



2x
4514195



2x
6225246



8x
6261375



22x
6326078



16x
4211475



2x
6052200



1x
6482568



16x
4211526



10x
4512360



1x
6380605



1x
6268924



104x
6173127



2x
4642934



42x
4211398



6x
6261353



2x
6382725



11x
6134378



11x
4211357



4x
6326078



2x
6435915



1x
6313114



1x
6092111



1x
6123809



2x
6213378



4x
6043656



1x
6265694



20x
4657366



1x
4558690



1x
6004990



2x
4654580



2x
4211568



18x
6446028



19x
6319336



56x
6093527



5x
6212077



2x
6045988



1x
4211881



2x
4211815



2x
6043639

3

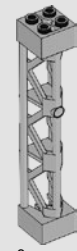

2x
6186292



1x
4211655



4x
6335279



6x
6438836



4x
4211429



1x
4558169



10x
6211969



1x
4580510



2x
6118827



58x
6456718



19x
6116608



2x
4211396



17x
4211445



7x
4211356



5x
6457283



1x
6257593



6x
6416524



9x
4211395



2x
4560183



2x
4211639



7x
6440545



6x
4565433



1x
6383116



2x
4211393



4x
4211438



2x
6353802

5

369

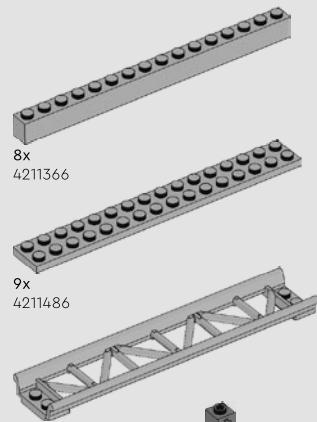
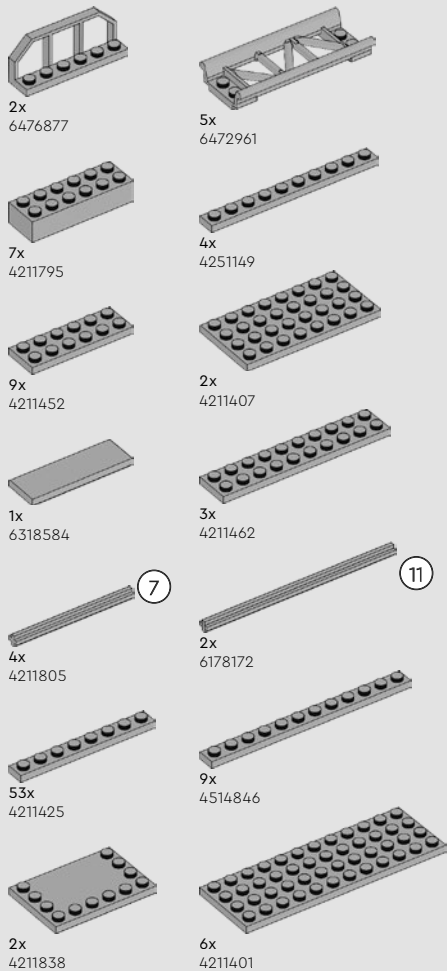

4

7

11



YOU COULD WIN



YOU COULD WIN

Your feedback will help shape the future development of this product series.

Visit:

DU KÖNNTEST GEWINNEN

Dein Feedback trägt zur Weiterentwicklung dieser Produktreihe bei.

Geh auf:

VOUS POURRIEZ GAGNER

Vos commentaires nous aideront à concevoir les futurs produits de cette gamme.

Visitez :

POTRESTI VINCERE TU

La tua opinione ci aiuterà a migliorare la creazione futura di questa linea di prodotti.

Visita:

PUEDES GANAR

Tu opinión contribuirá al futuro de esta serie de productos.

Visita:

轻松获奖

您的反馈将有助于我们在今后改进本产品系列。

请访问:

[LEGO.com/productfeedback](https://www.lego.com/productfeedback)

You also have the chance to win a LEGO® set.

Terms and conditions apply.*

Außerdem hast du die Chance, ein LEGO® Set zu gewinnen.

Es gelten die Teilnahmebedingungen.*

Vous pourriez également gagner un ensemble LEGO®.

Des conditions s'appliquent.*

Hai anche la possibilità di vincere un set LEGO®.

Termini e condizioni sono applicabili.*

También tienes la oportunidad de ganar un set LEGO®.

Aplican términos y condiciones.*

您还有机会赢取乐高®套装。

条款和条件适用。*

*[LEGO.com/productfeedback-terms](https://www.lego.com/productfeedback-terms)

LEGO and the LEGO logo are trademarks of the LEGO Group. ©2024 The LEGO Group.

NASA Insignia and identifiers provided and used with permission of NASA.

This product is developed in collaboration with the European Space Agency (ESA) for the purpose of fostering children's interest in space science.
ESA is not involved in the manufacturing and commercialisation of this product.

