

TITANIC

LIBRO 2

EL BUQUE DE PASAJEROS MÁS LUJOSO DEL MUNDO

Diseñado como máximo exponente del estilo, el confort y el lujo, el *Titanic* aspiraba a transmitir la impresión de ser un hotel flotante, no solo un barco. Ofrecía a sus 833 pasajeros de primera clase una amplia gama de instalaciones a bordo, como un gimnasio, una cancha de *squash*, una piscina, bibliotecas, exquisitos restaurantes y suntuosos camarotes. Nada había en todo el transatlántico que destacara por encima de la Gran Escalera, construida en roble macizo, que descendía por sus siete cubiertas describiendo una magnífica curva.



↑ Escalinata de primera clase en la zona de popa que conducía al restaurante à la carte.

→ Menú de la cena servida al pasaje de segunda clase el 14 de abril de 1912, fecha en que el Titanic chocó con el iceberg que causó su hundimiento.



↓ Sala de lectura en la cubierta de paseo superior.



↓ Salón de primera clase.



↓ Gimnasio de primera clase.

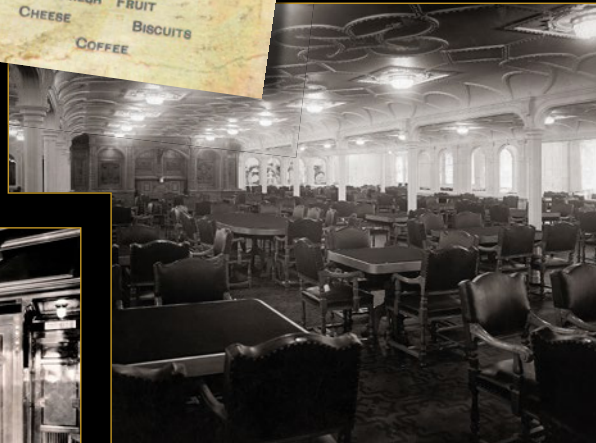
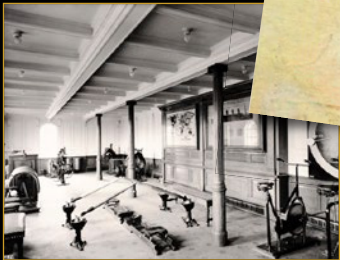

↑ Comedor principal.



↑ Café Parisien, creado como ampliación del restaurante de primera clase.



↑ Suite B-57 de primera clase en todo su elegante esplendor.

CONSTRUCCIÓN DEL *TITANIC*

Lo que comenzó como un prototipo durante una sesión de construcción libre para diseñadores de LEGO® se convirtió rápidamente en uno de los sets LEGO más grandes jamás creados. Sin embargo, las impresionantes dimensiones de este modelo nunca fueron un objetivo por sí mismo. Su escala fue creciendo a medida que al equipo de diseño se le ocurrían nuevos elaborados detalles que les parecían imprescindibles. Por ejemplo, para el veterano diseñador de LEGO Mike Psiaki, había que crear réplicas de los motores de vapor con pistones móviles usando elementos LEGO Technic. Una vez definido el diseño inicial, el equipo dedicó una semana entera a construir diferentes versiones del modelo mientras decidían qué necesitaba reforzarse o simplificarse.

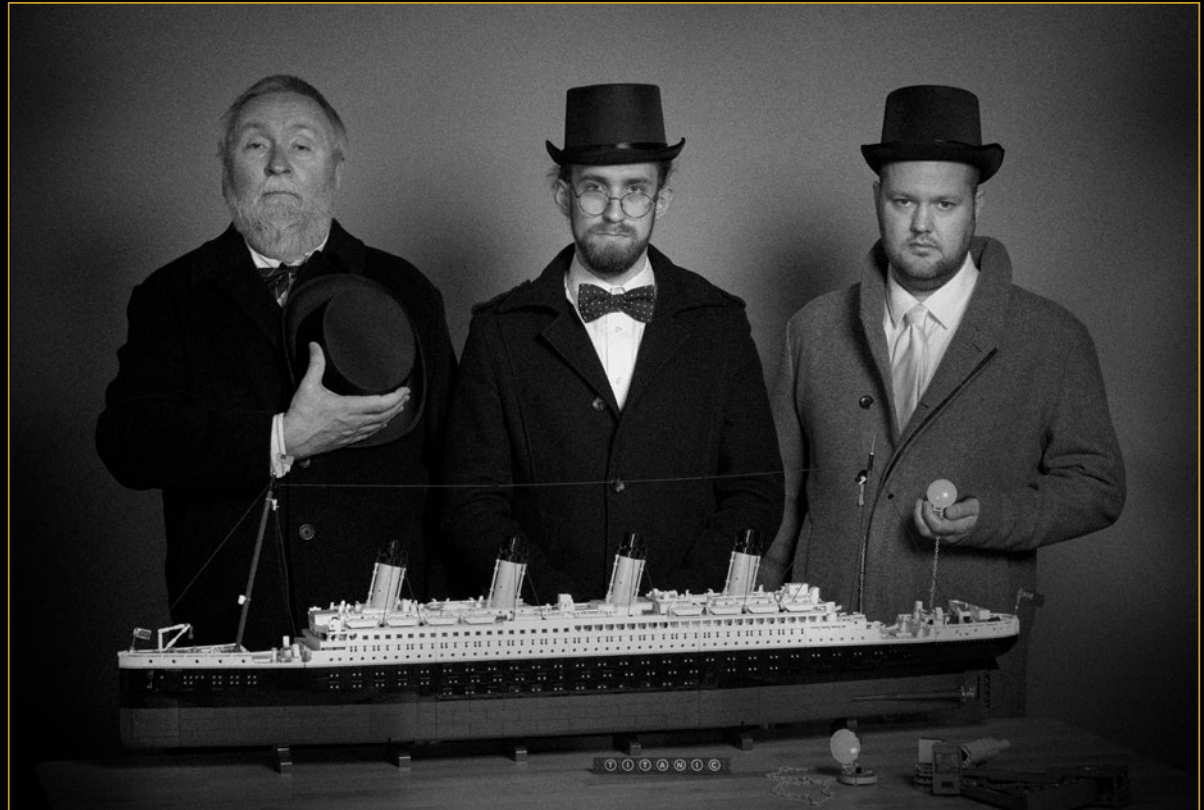

↑ Algunos integrantes del equipo de LEGO® a cargo de este modelo (de izquierda a derecha): Torben Kidde Skov (orientador de modelos sénior), Mike Psiaki (maestro de diseño) y Martin Højen Holm Buk (experto en instrucciones de construcción).

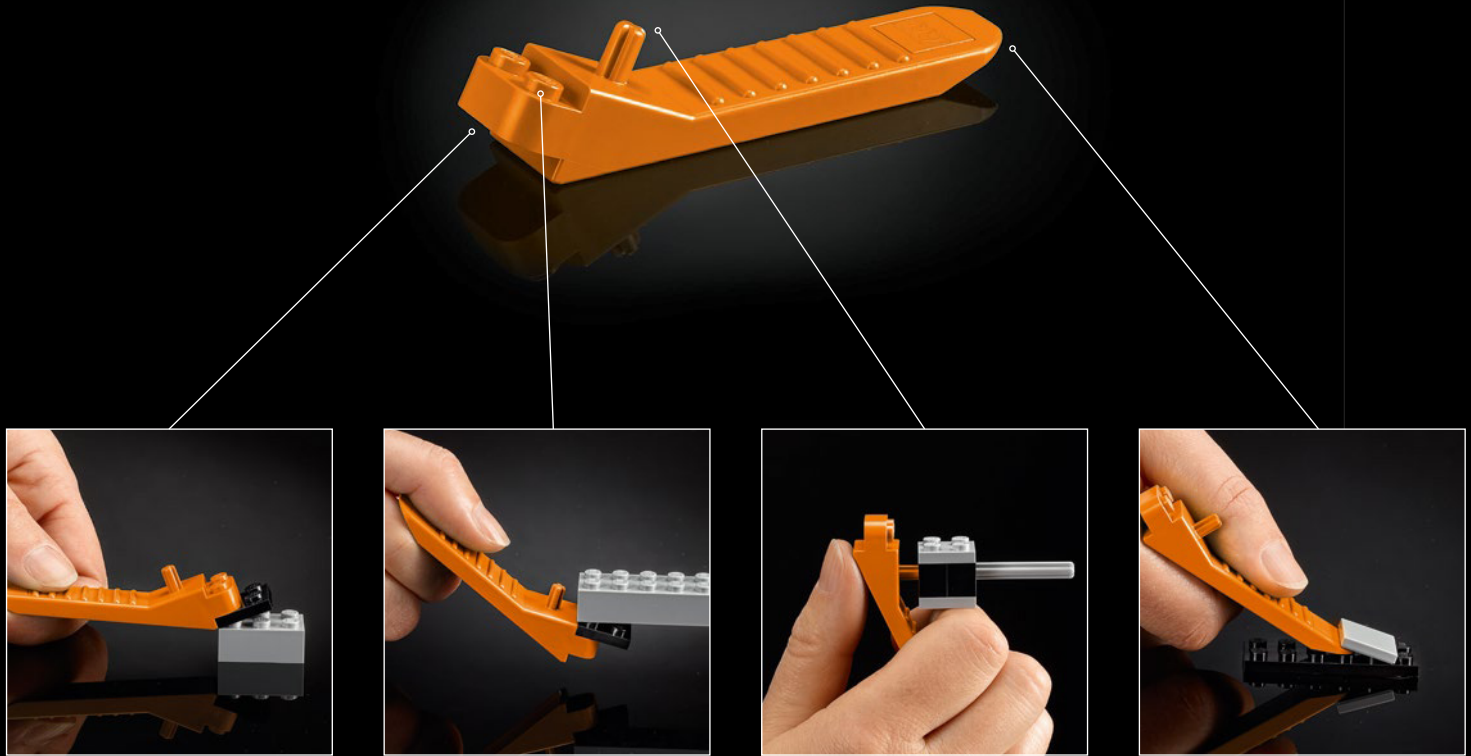

[LEGO.com/brickseparator](https://www.lego.com/brickseparator)

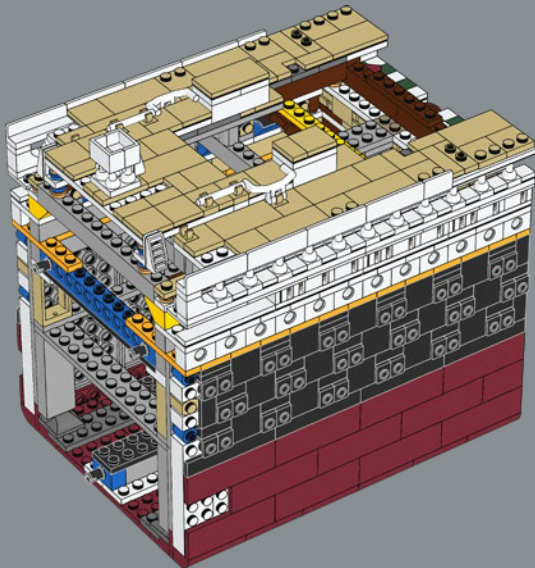
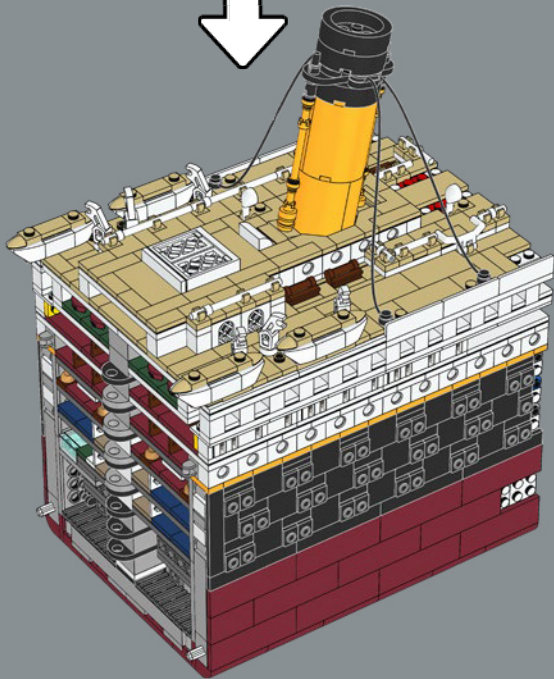

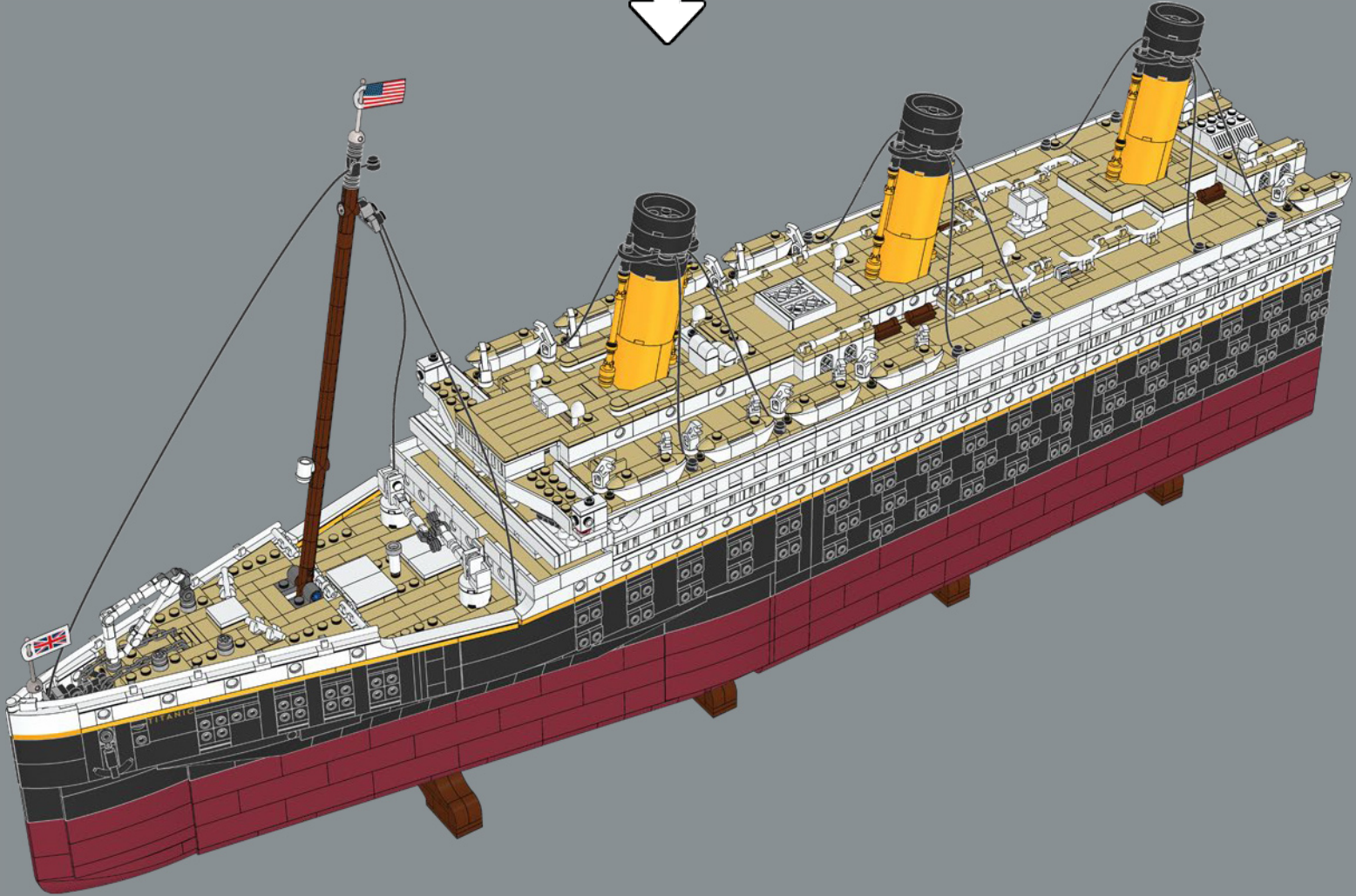
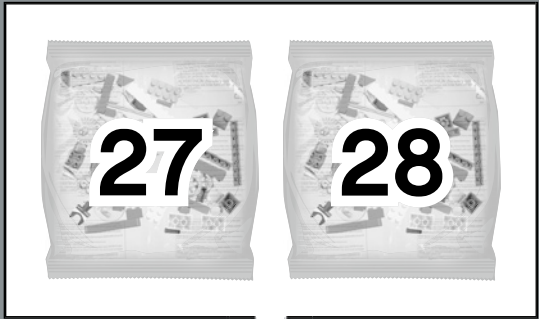

↓ La segunda mitad del mecanismo de fijación que mantiene unidas las 3 secciones principales del barco se construye en esta fase.

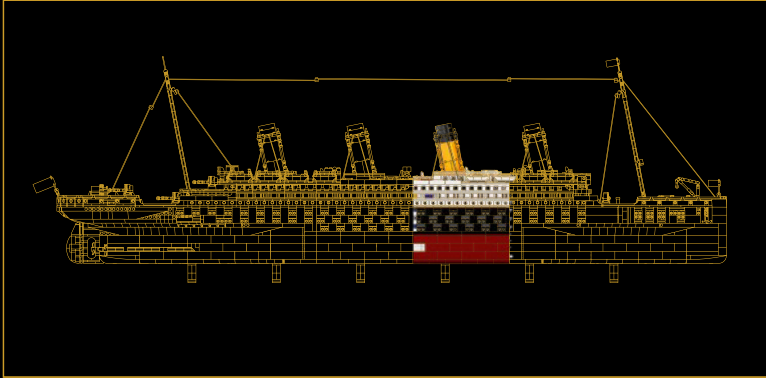

SECCIÓN 3:

CHIMENEA Y CAMAROTES PRINCIPALES

En esta fase inicias una nueva sección transversal del barco, en la que construirás varias carboneras de las cubiertas inferiores y numerosos camarotes de diferentes clases. La superestructura de esta sección contiene los comienzos de las cubiertas de paseo del buque, la claraboya que brindaba luz natural a la Gran Escalera y la segunda chimenea.



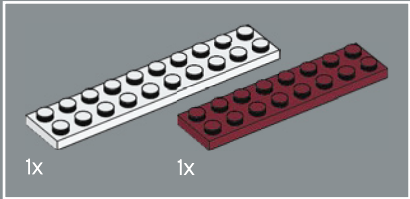
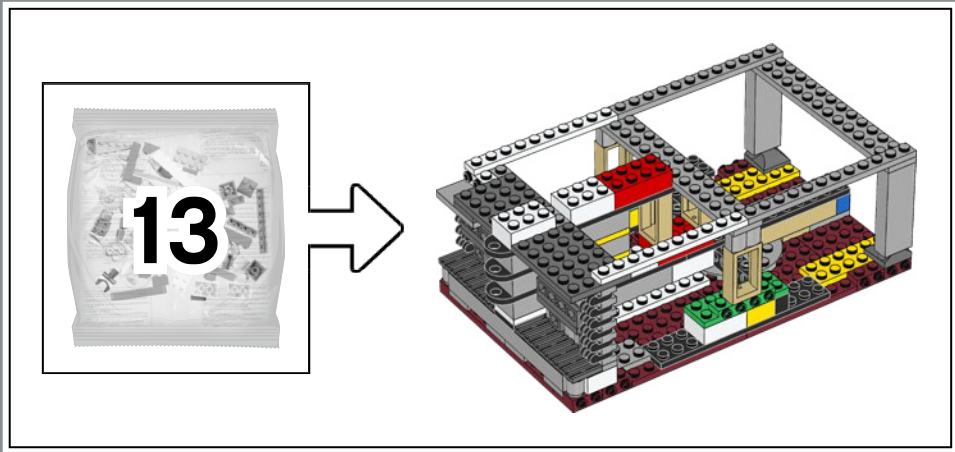

1

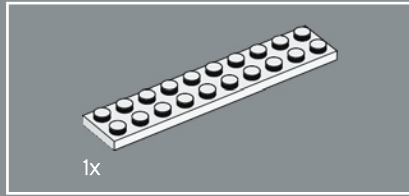
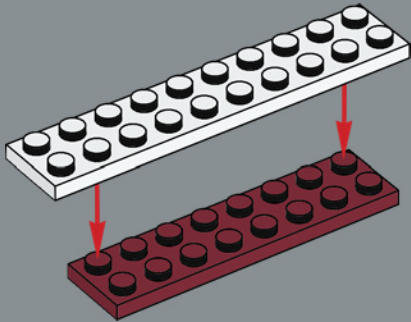

2

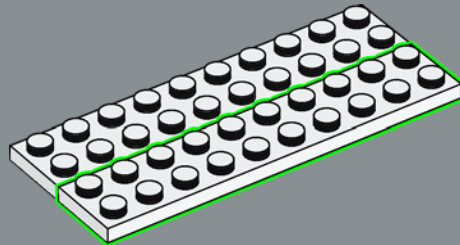

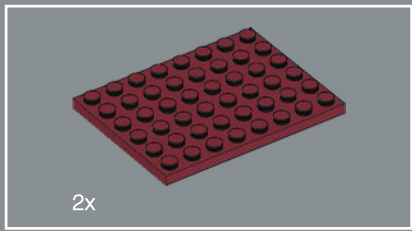

3

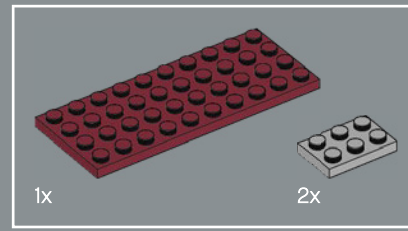
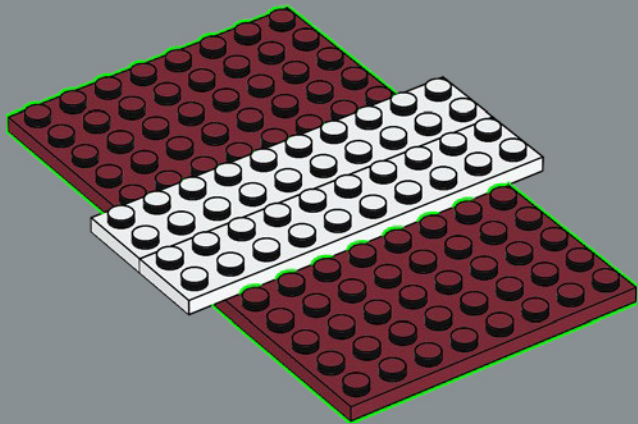

4

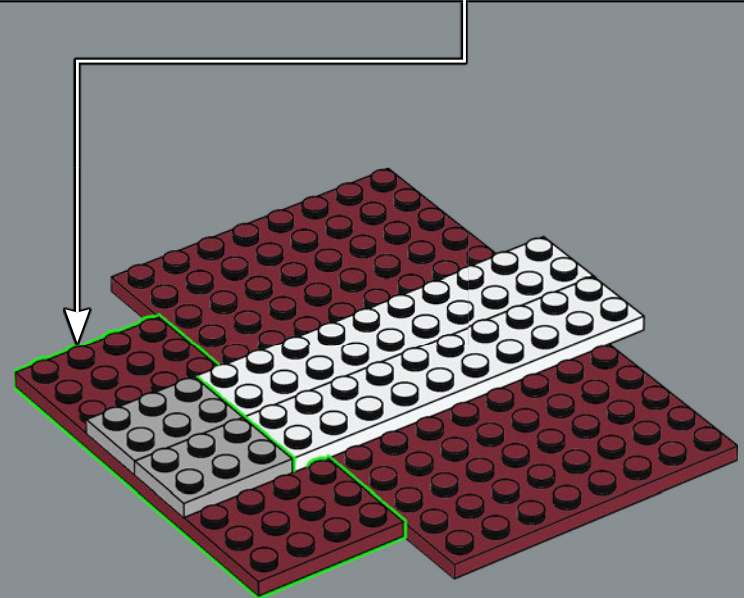
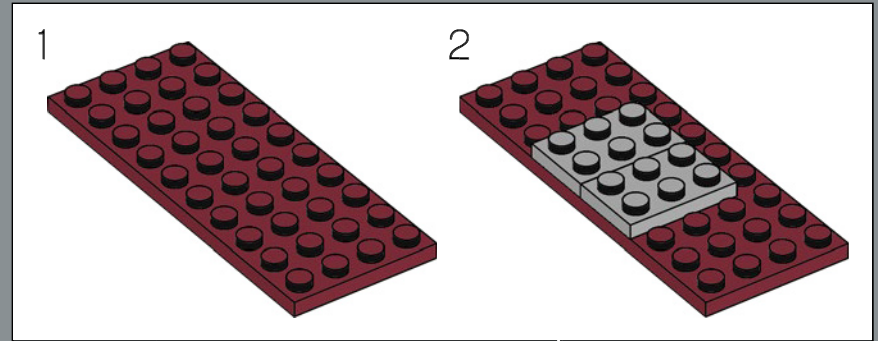

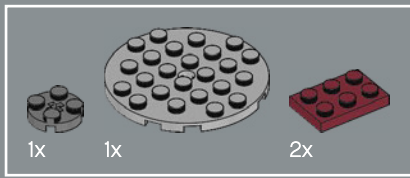

5

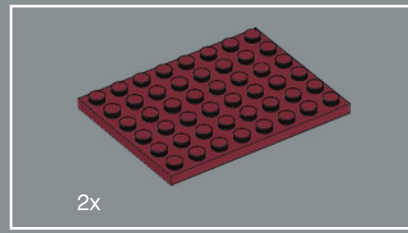
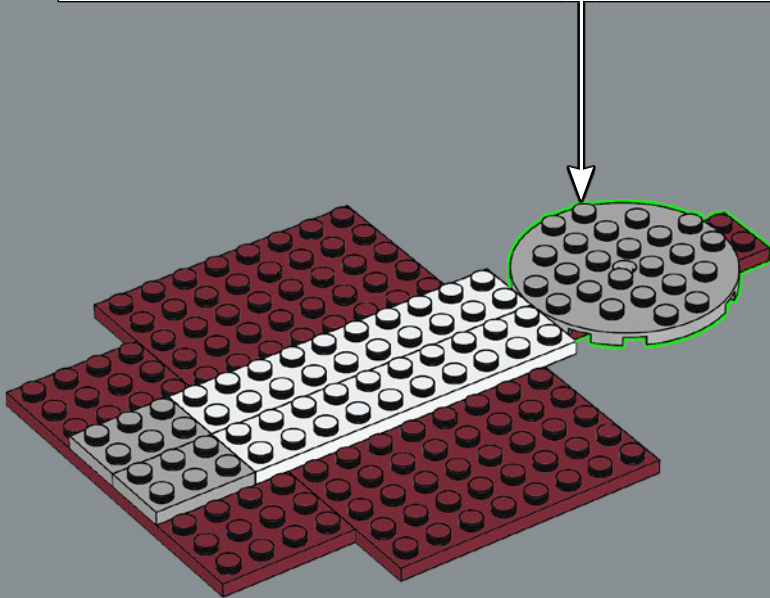
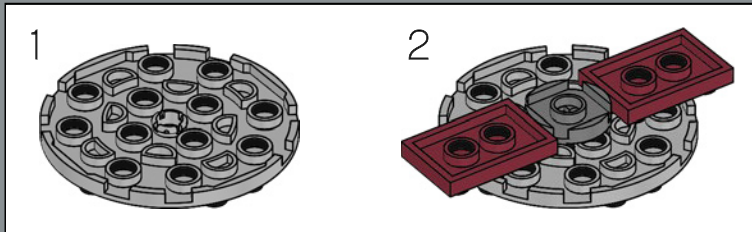

6

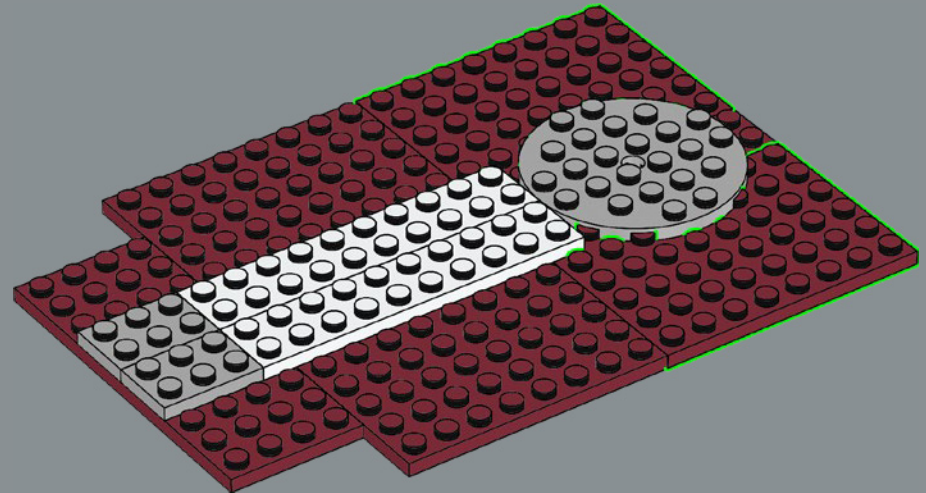

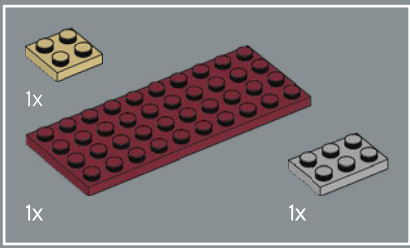

7

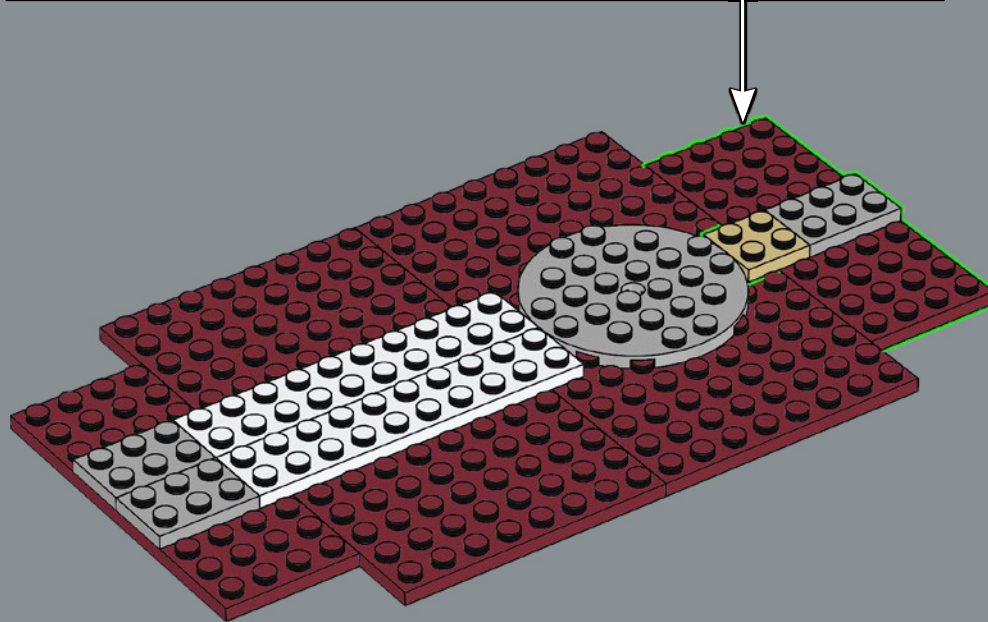
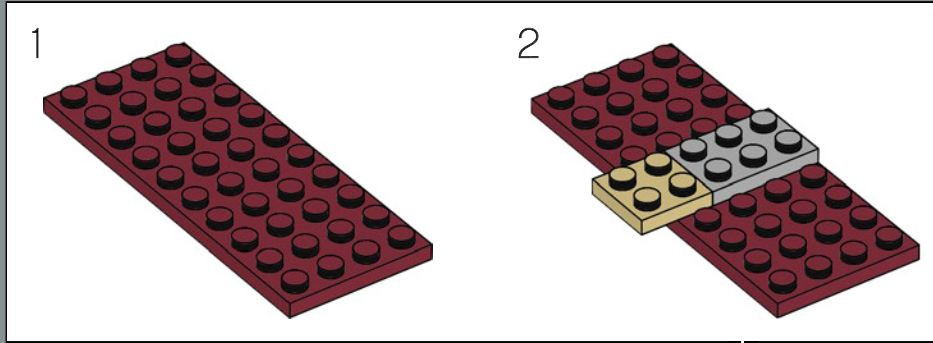

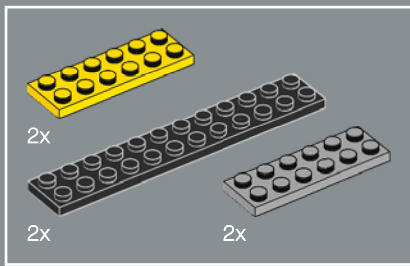

8

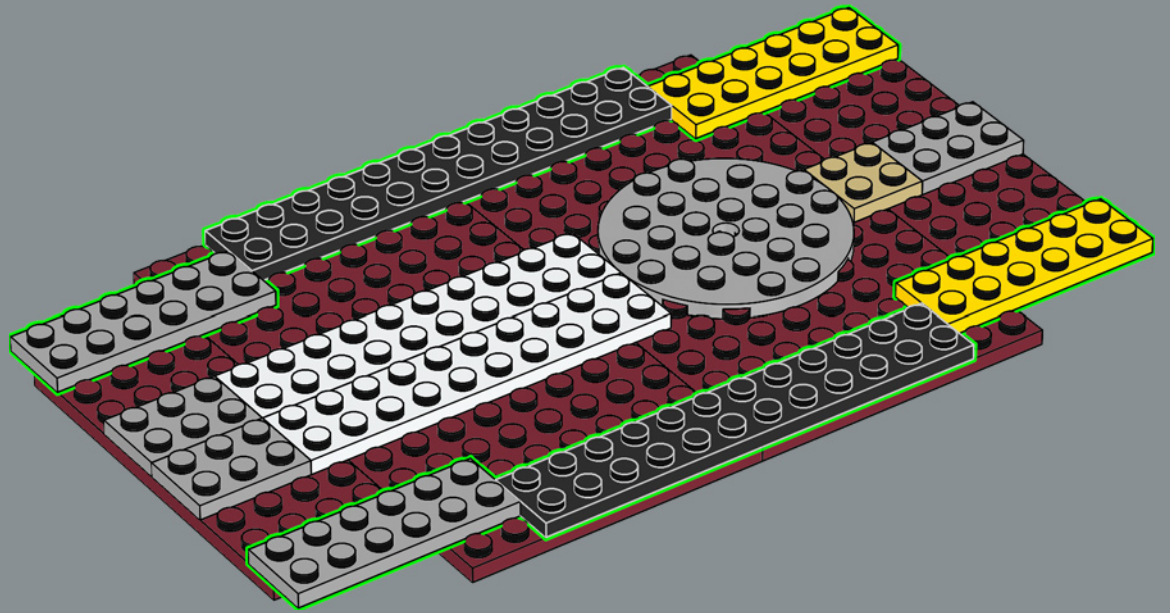

9

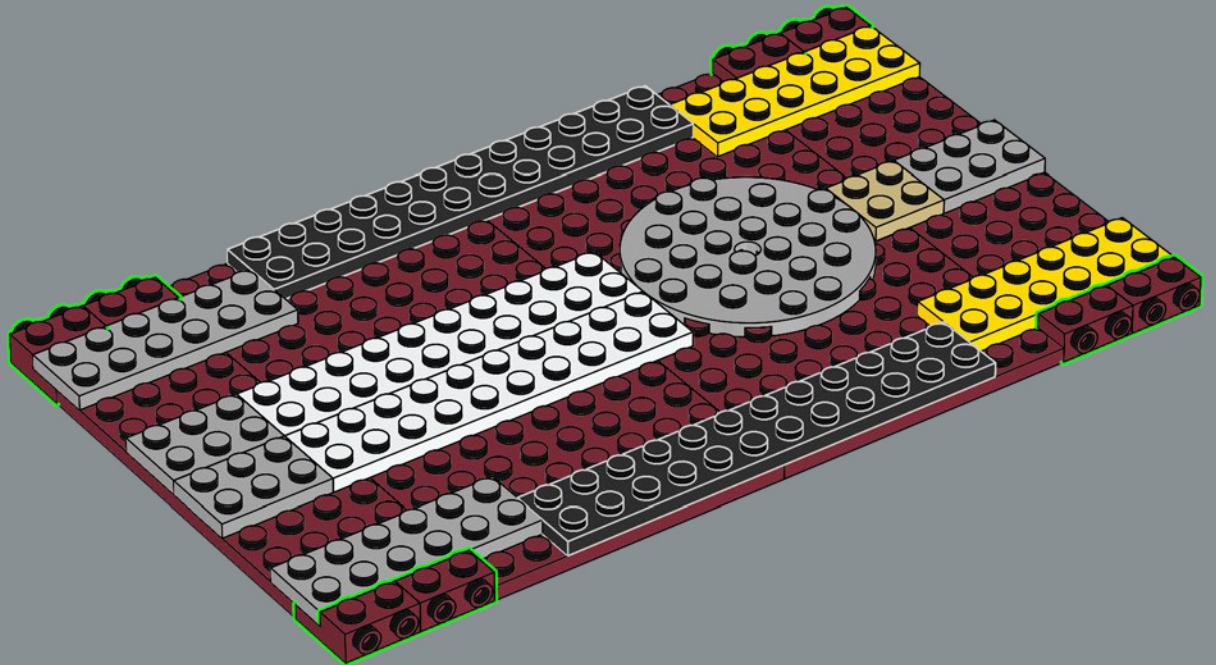

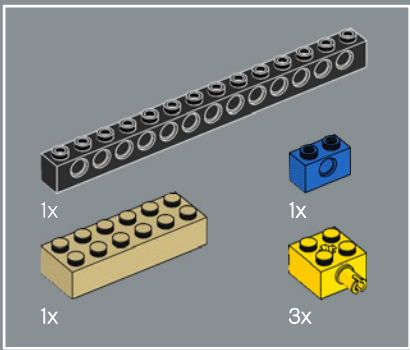

10

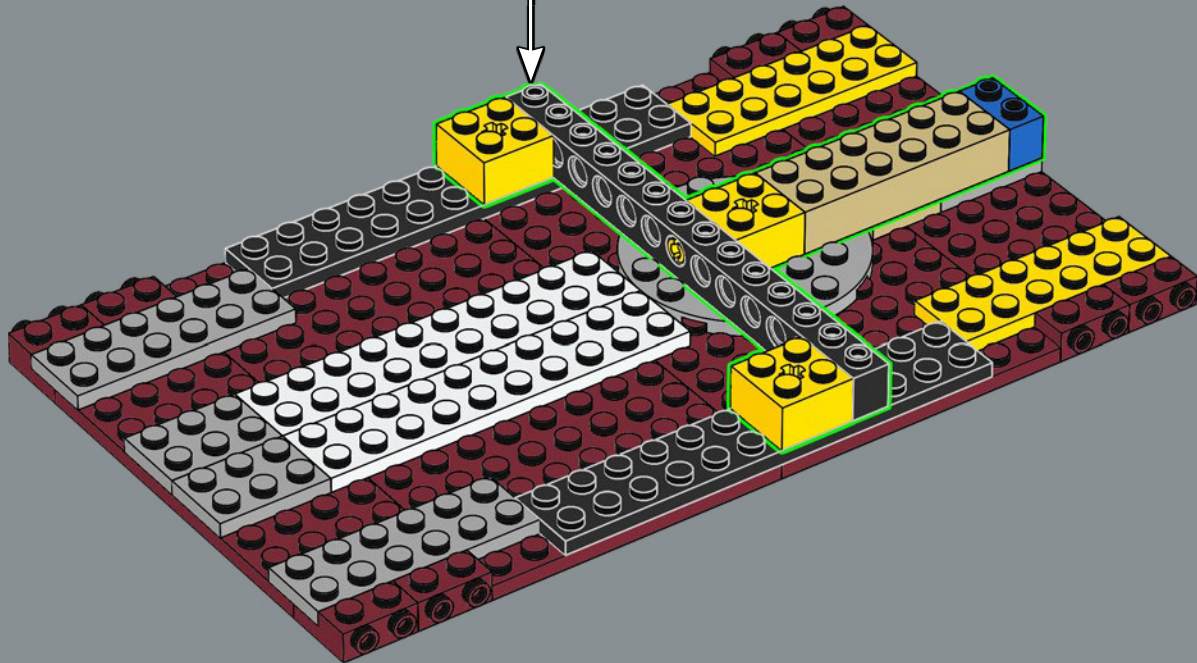
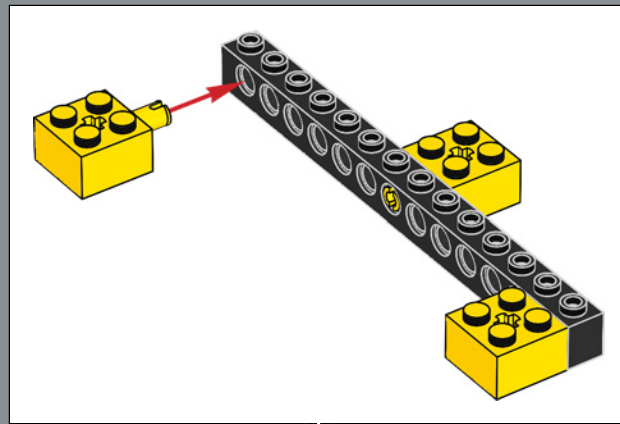

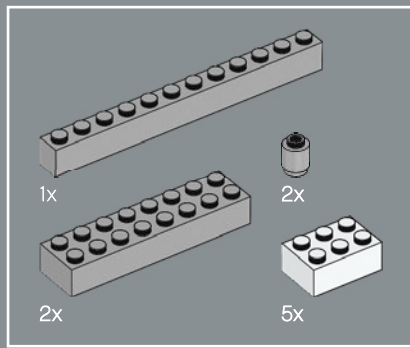

11

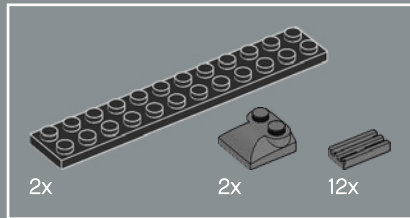
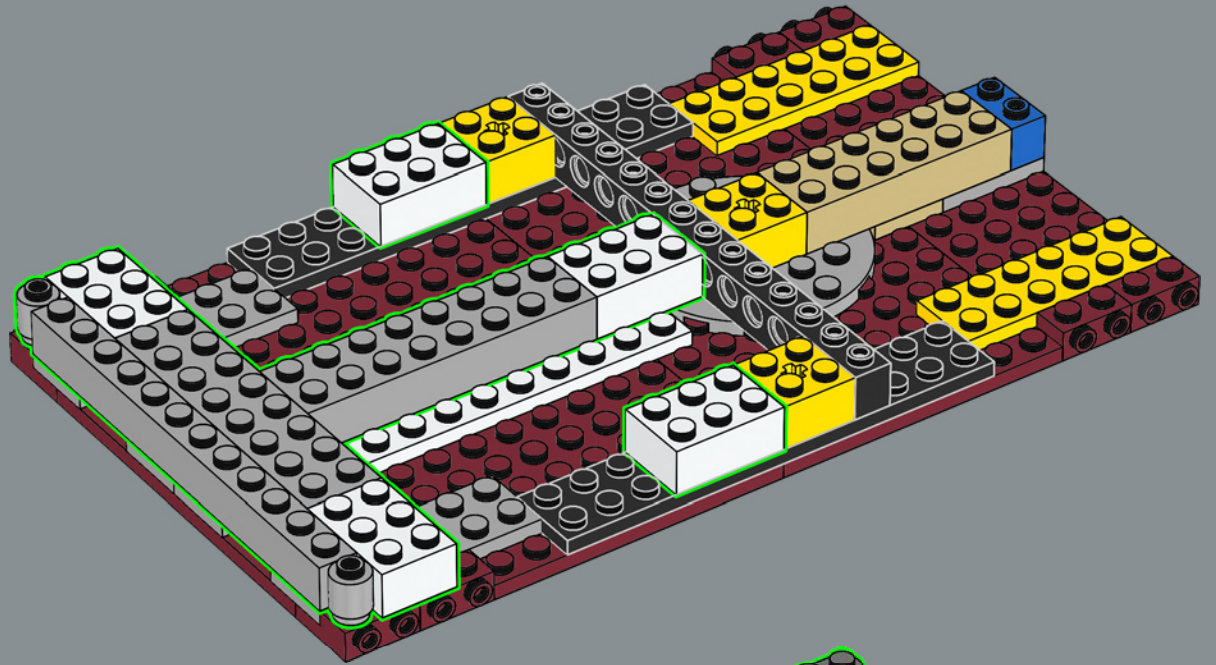

12

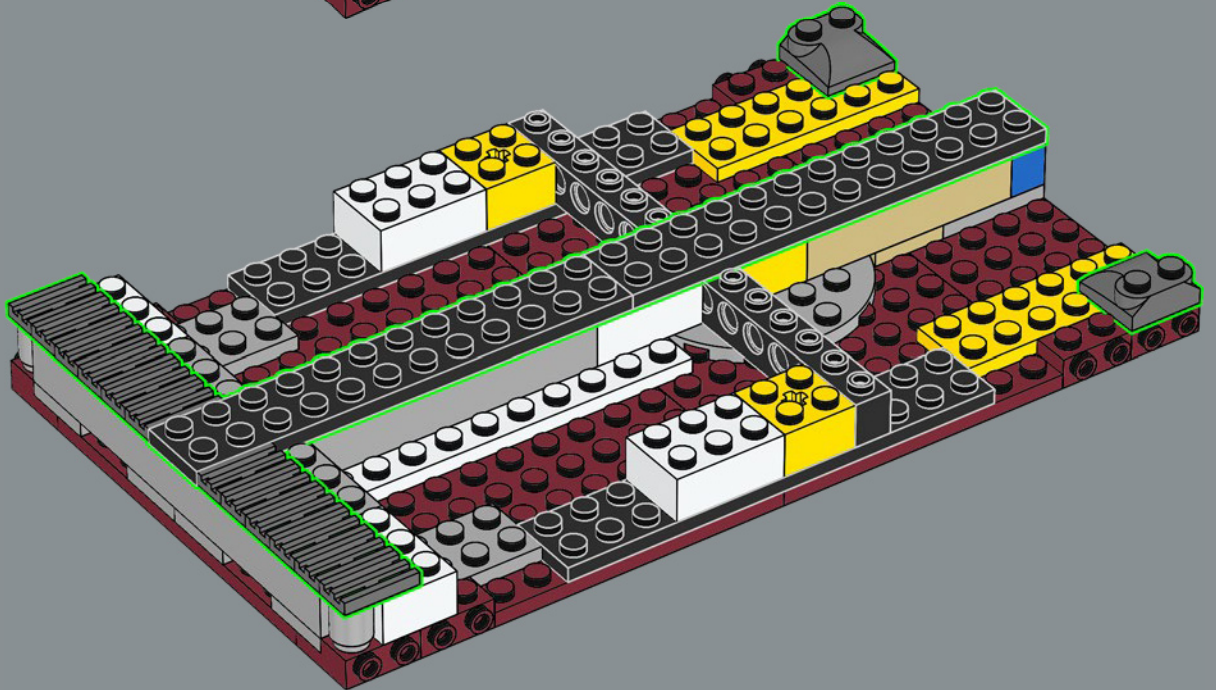

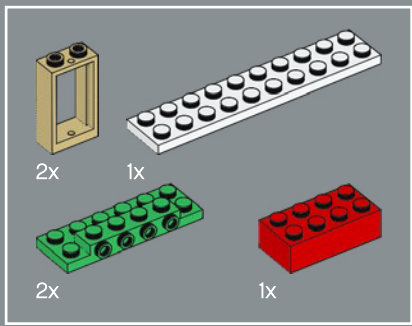

13

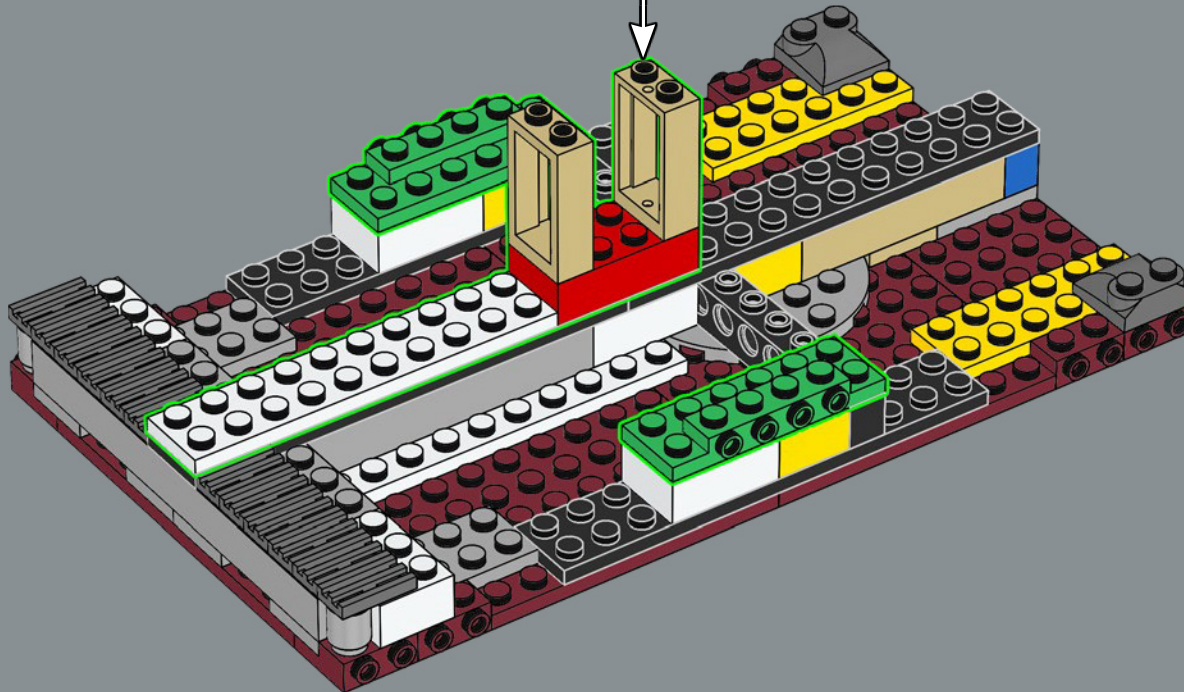
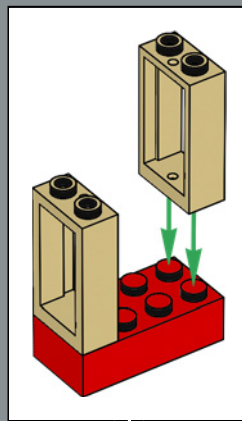

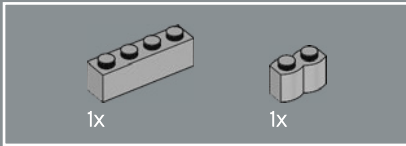
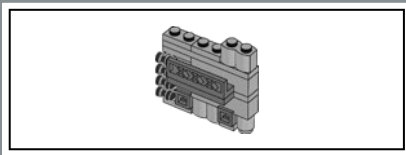

14

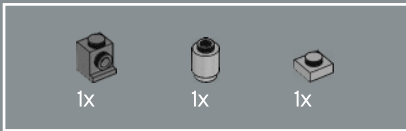
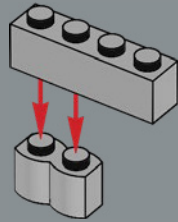

15

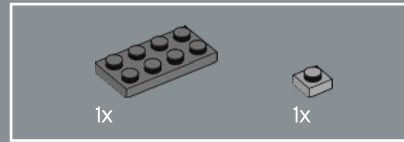
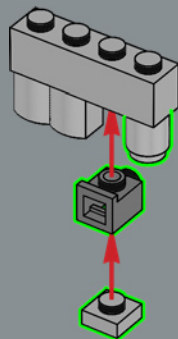

16

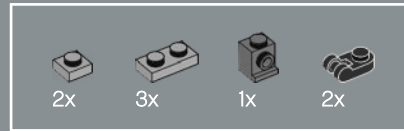
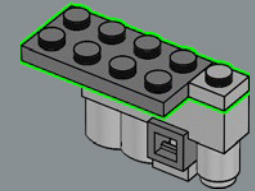

17

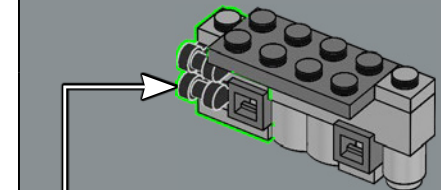
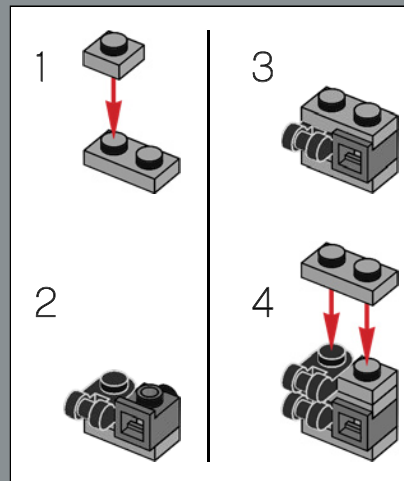



18

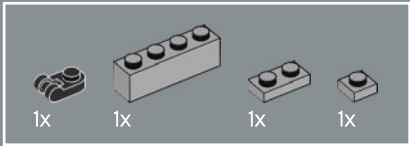
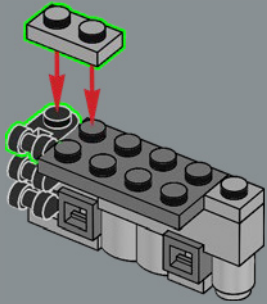

19

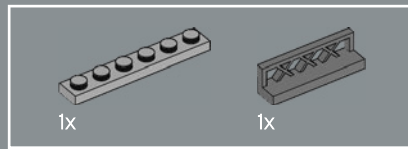
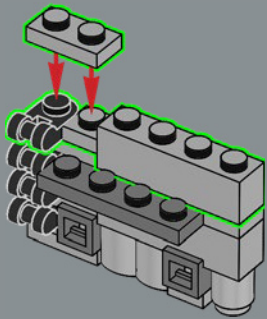

20

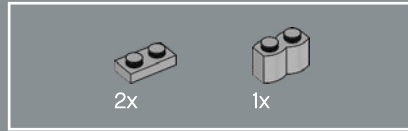
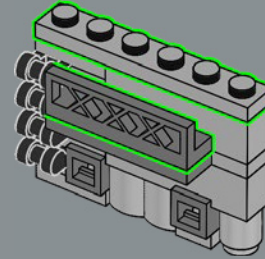

21

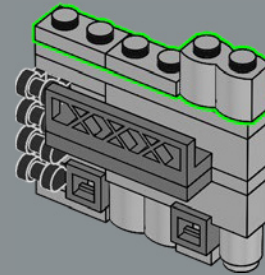

22

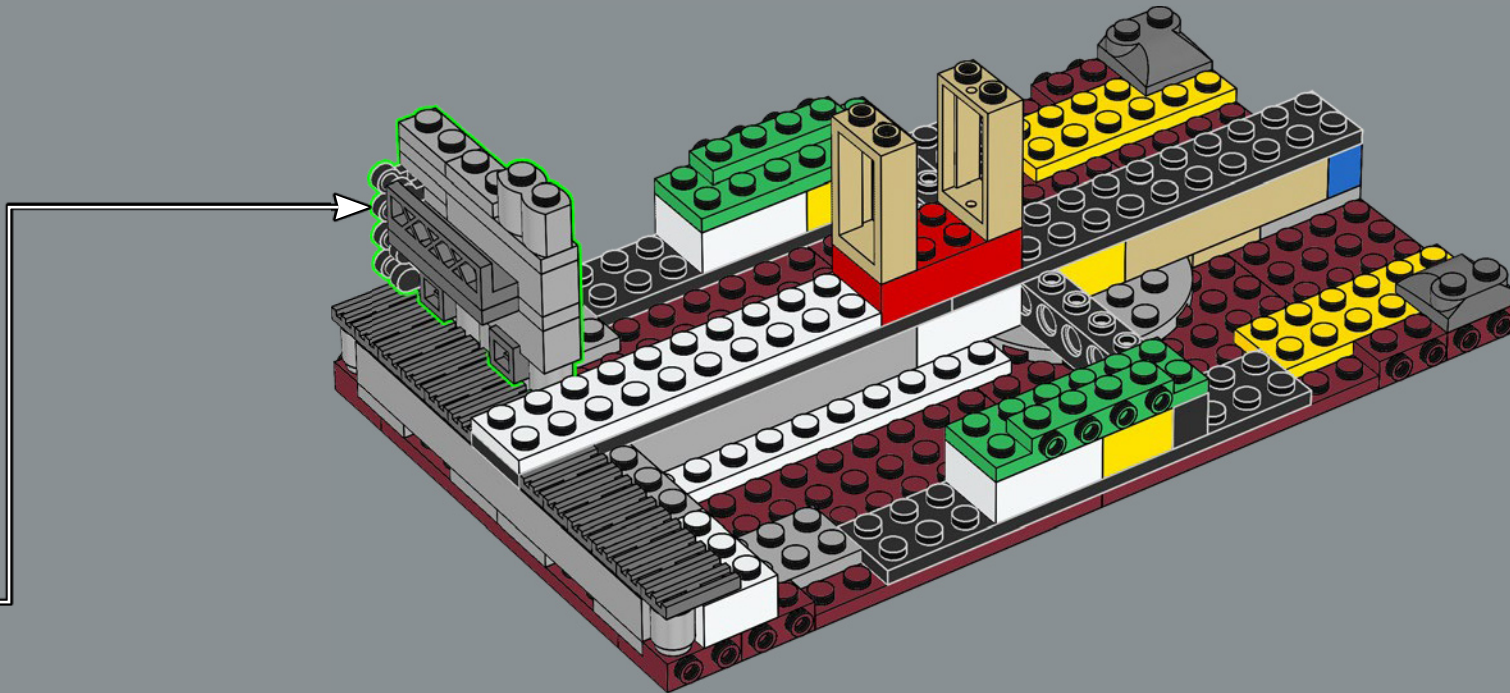

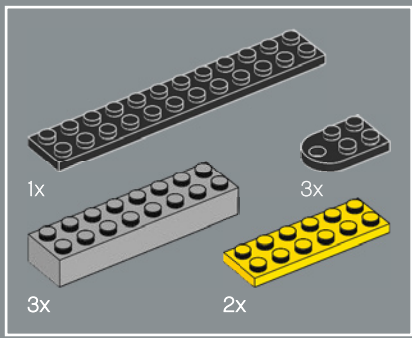

23

1

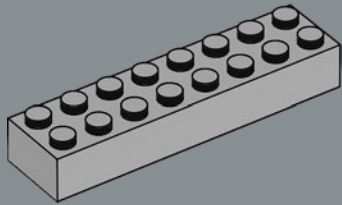

2

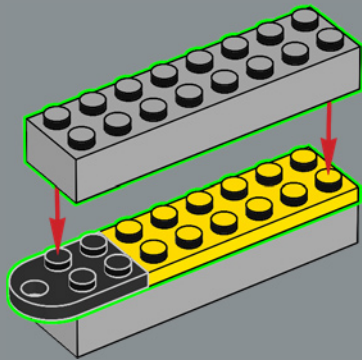

3

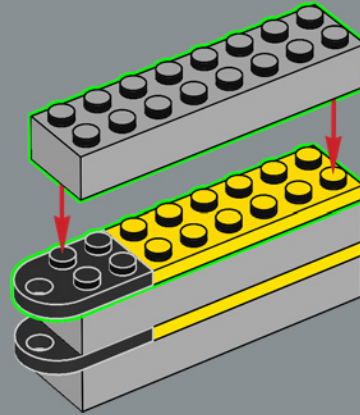

4

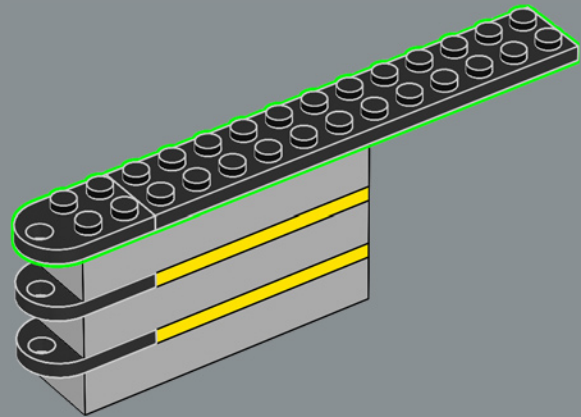

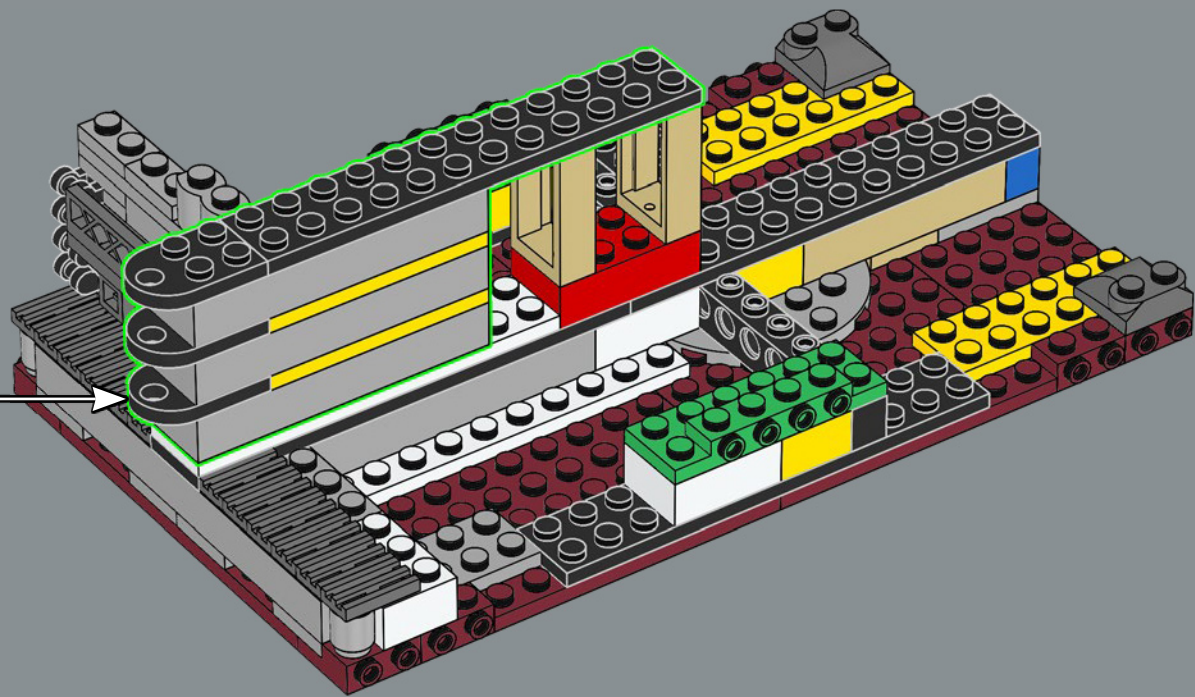

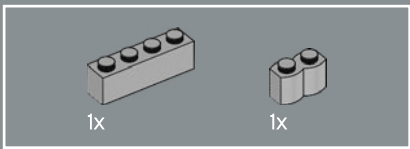

24

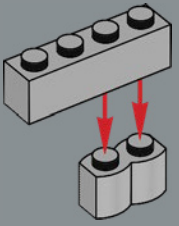

25

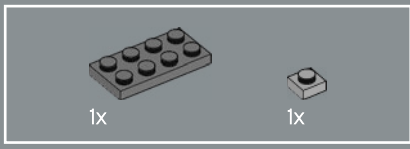
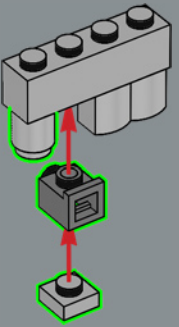

26

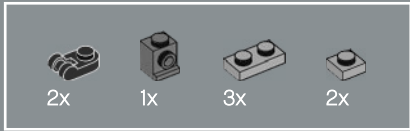
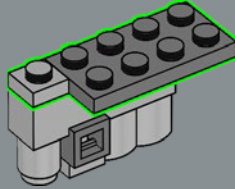

27

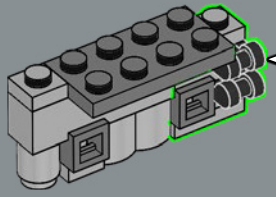
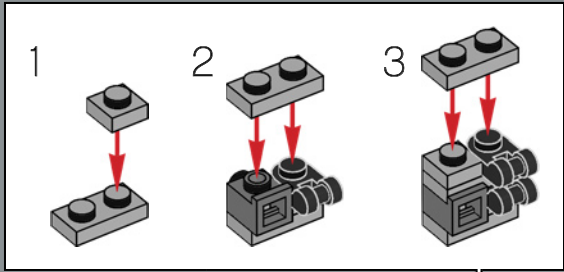

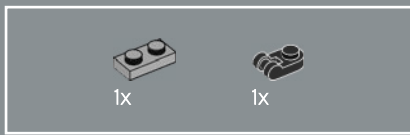

28

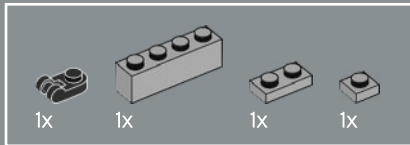
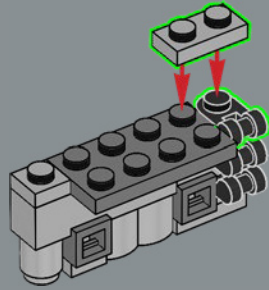

29

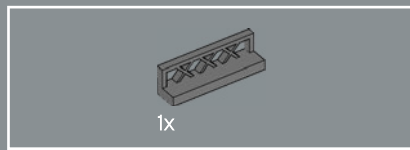
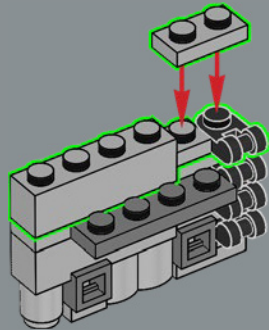

30

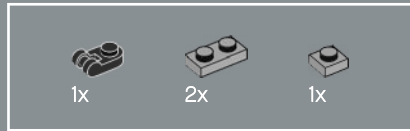
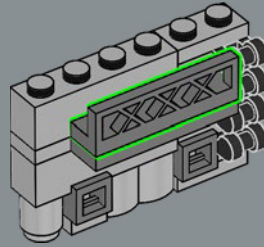

31

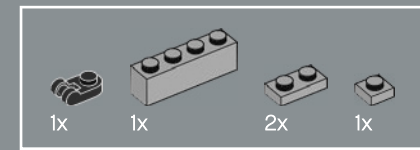
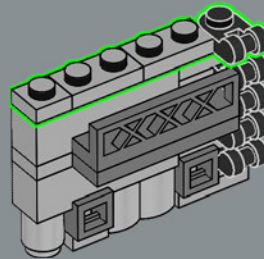

32

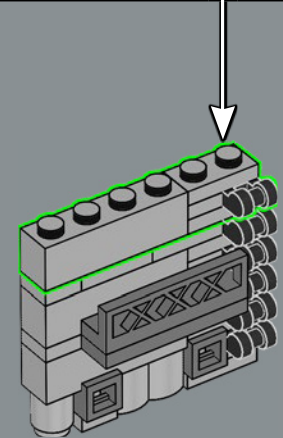
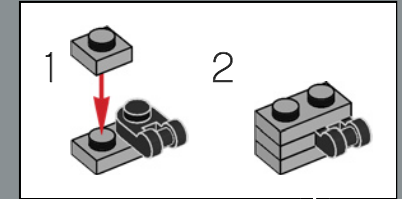

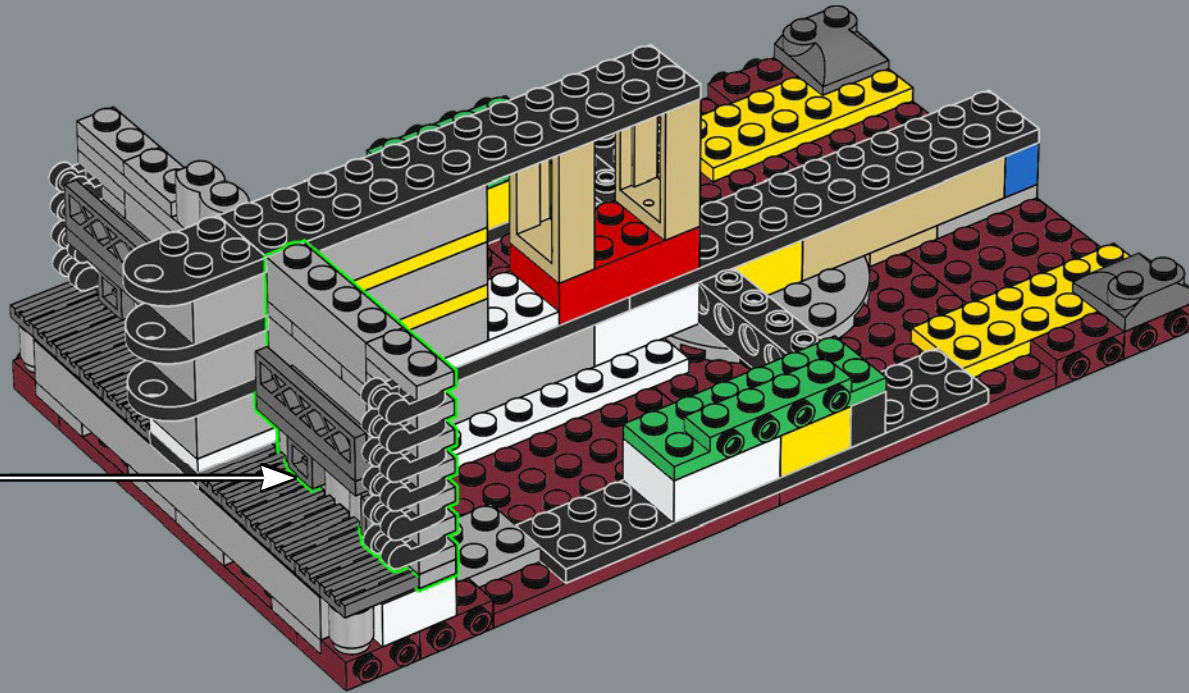

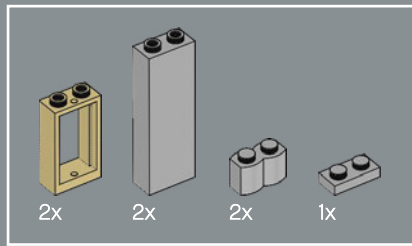

34

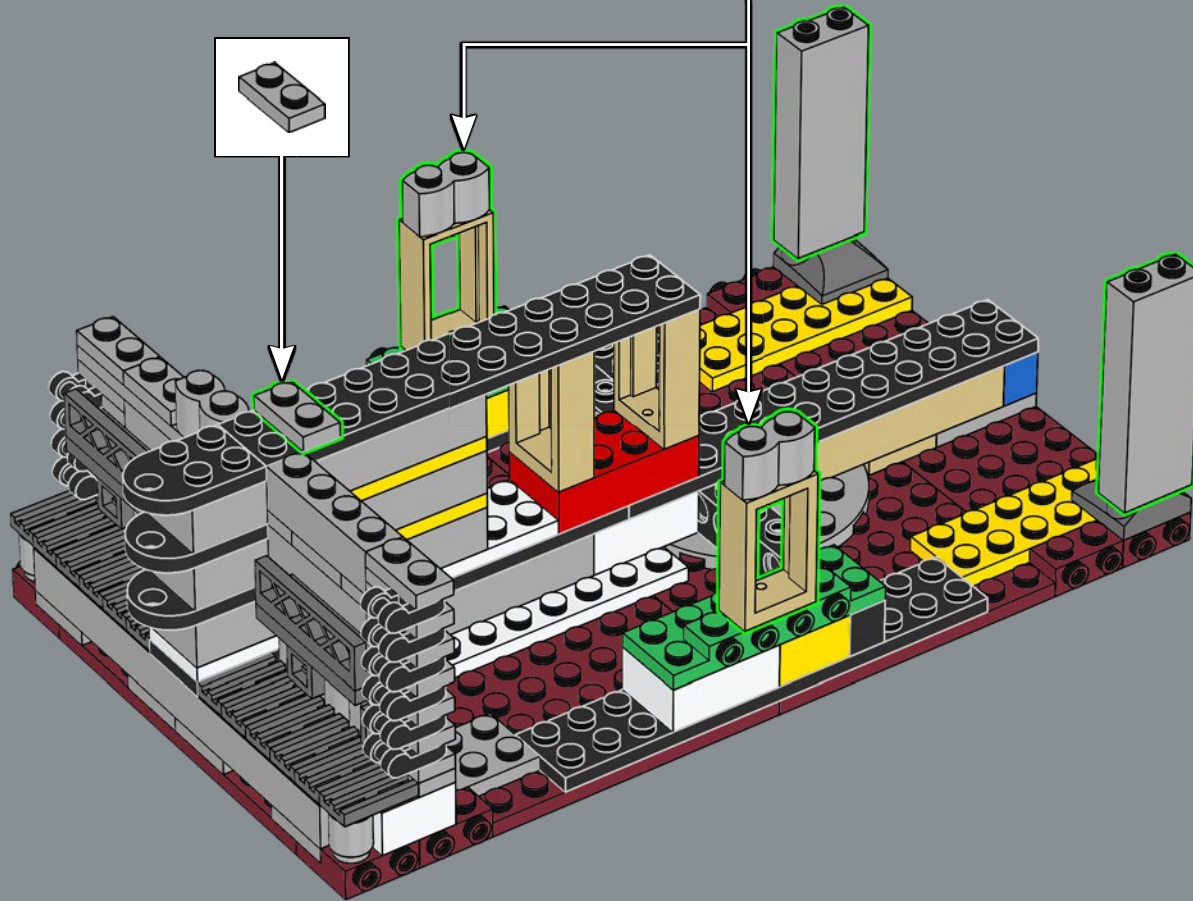
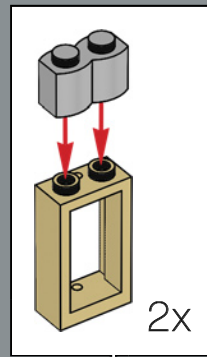

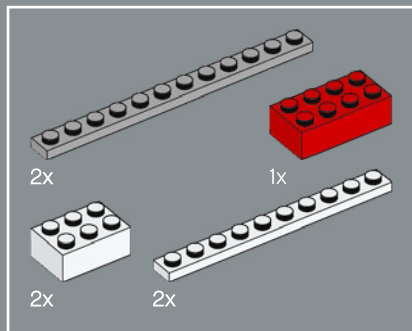

36

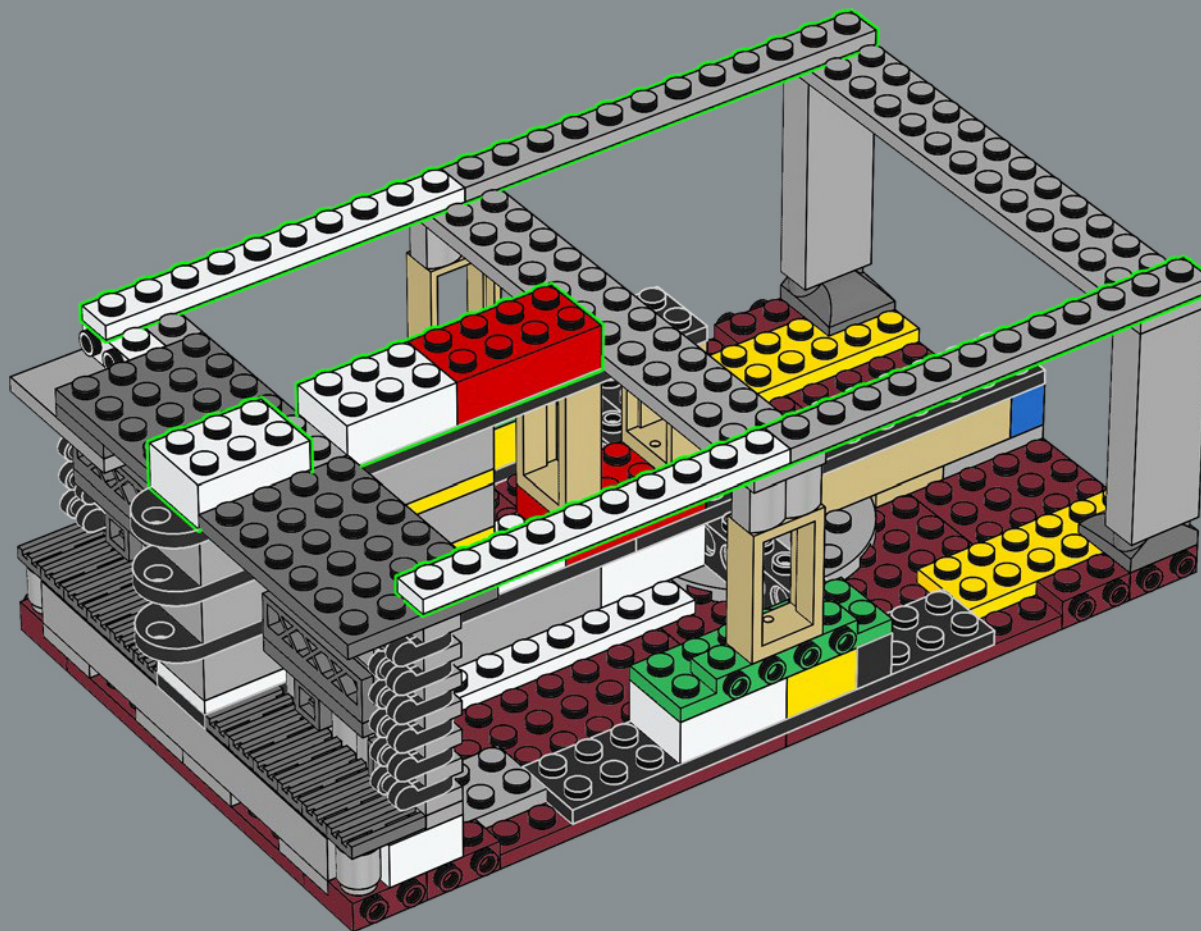

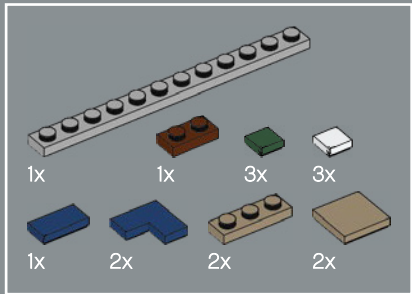
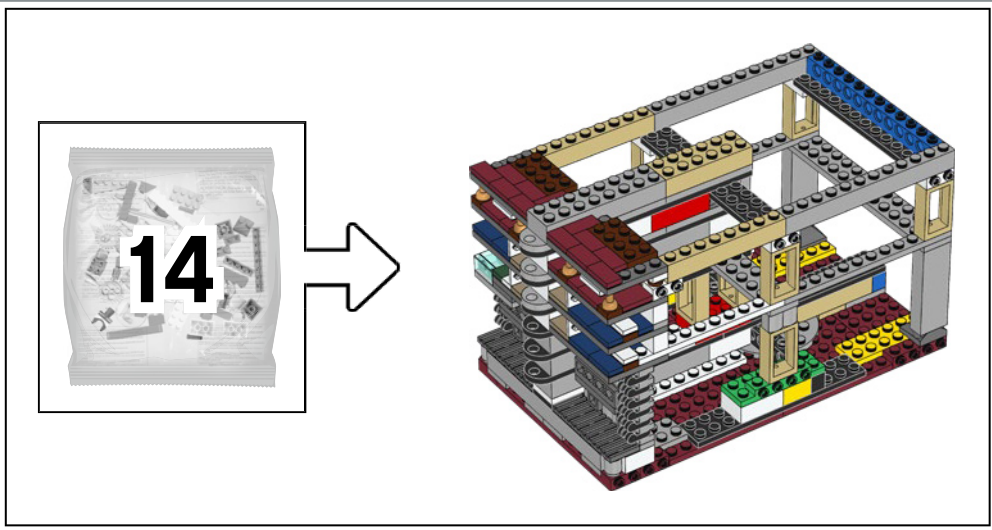

37

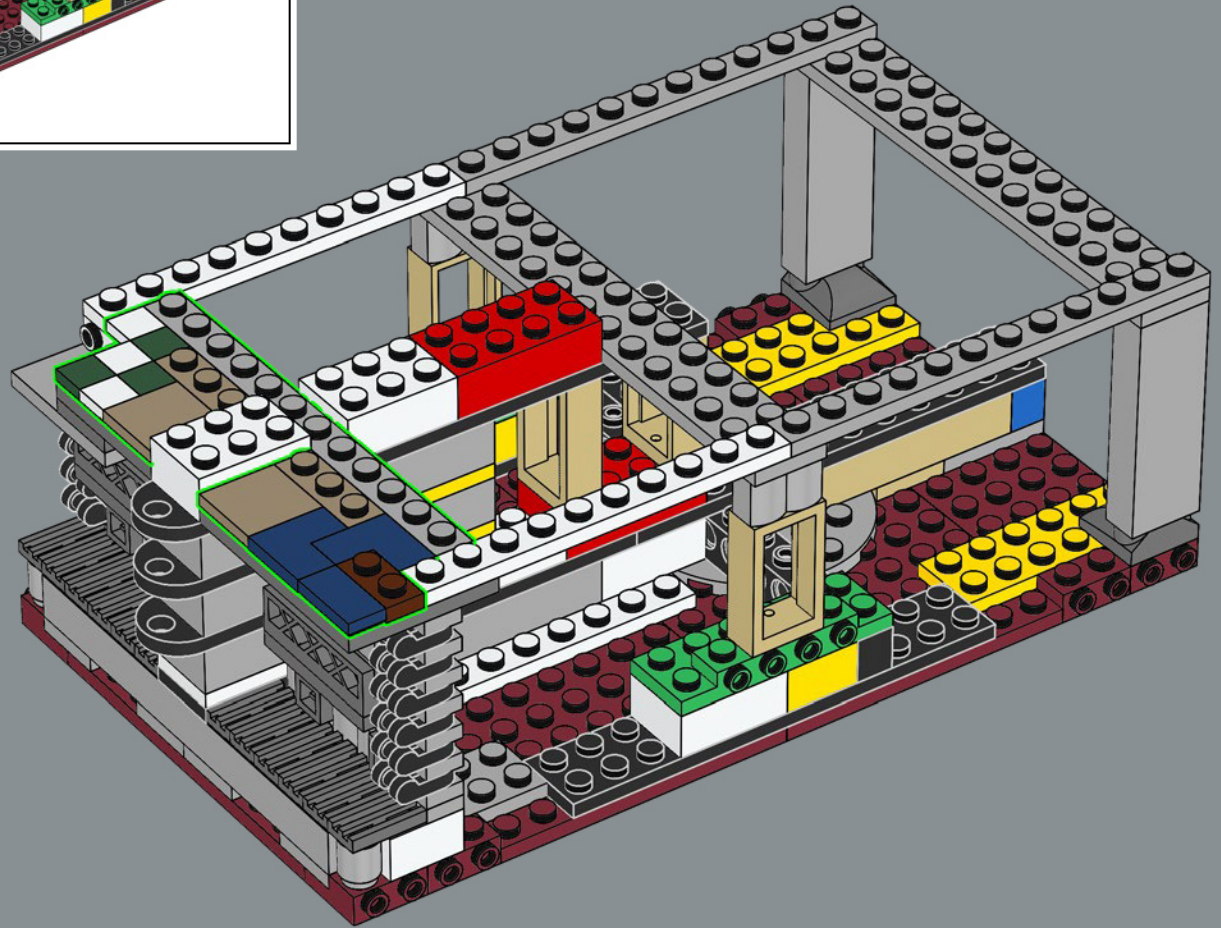

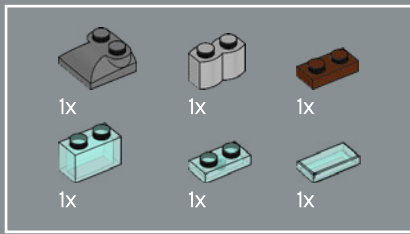

38

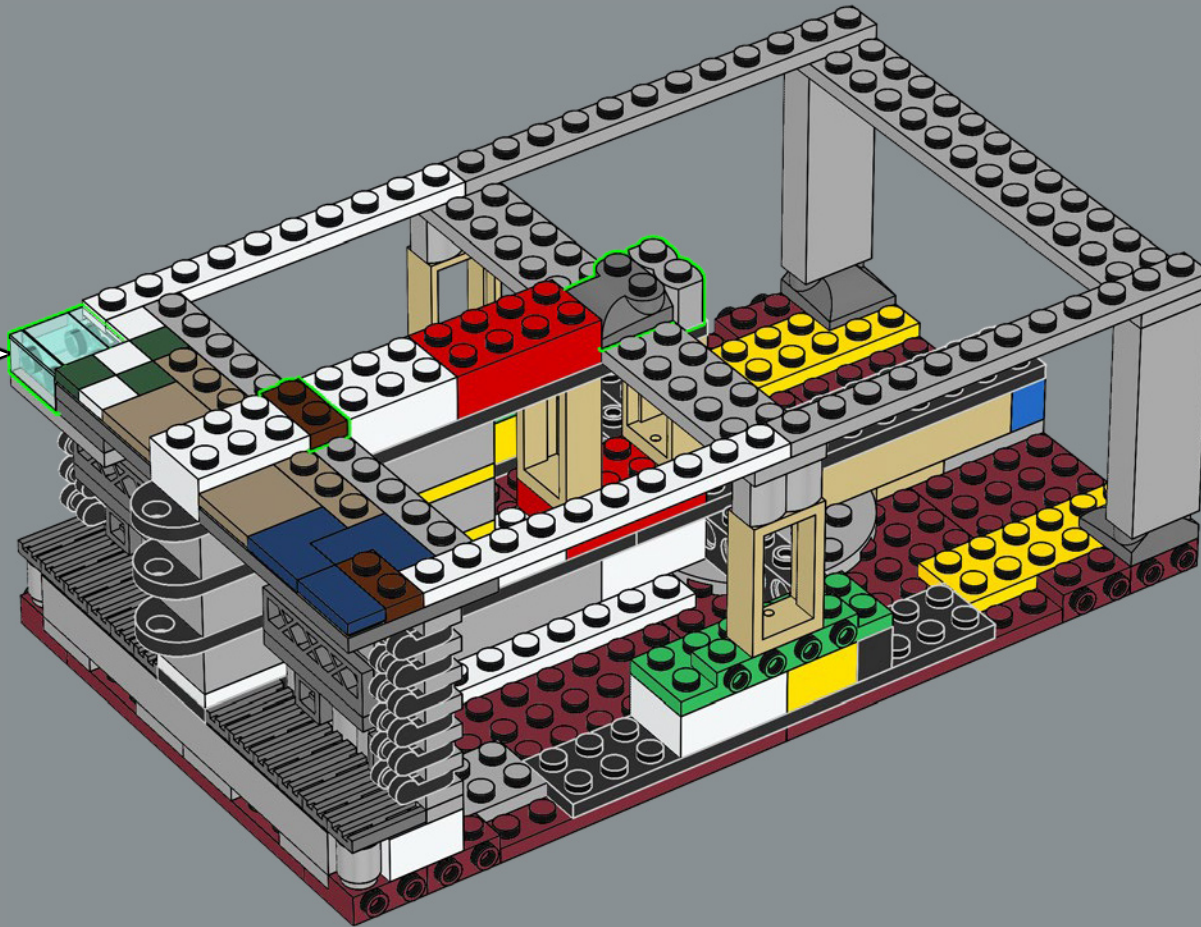
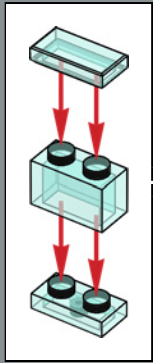

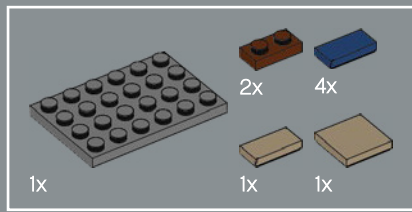

40

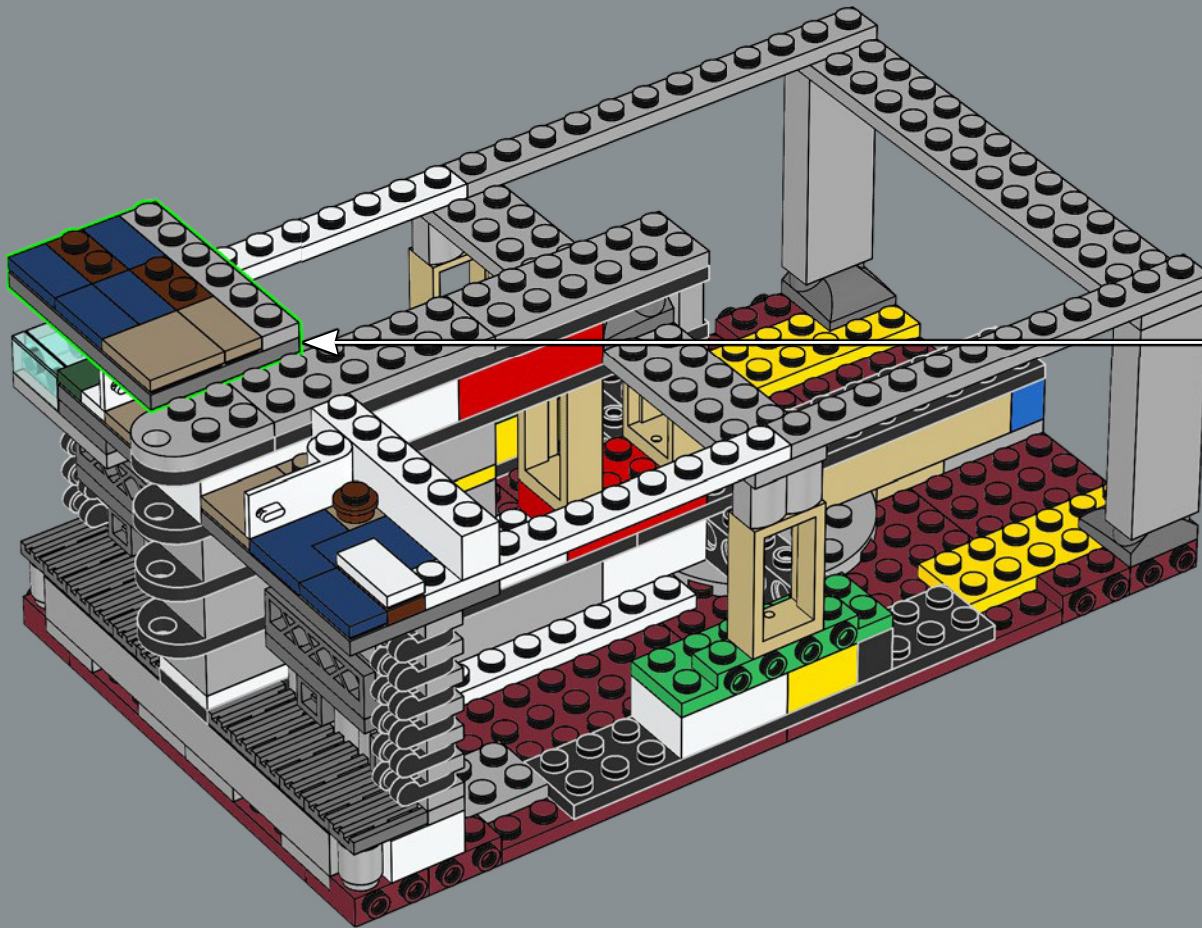
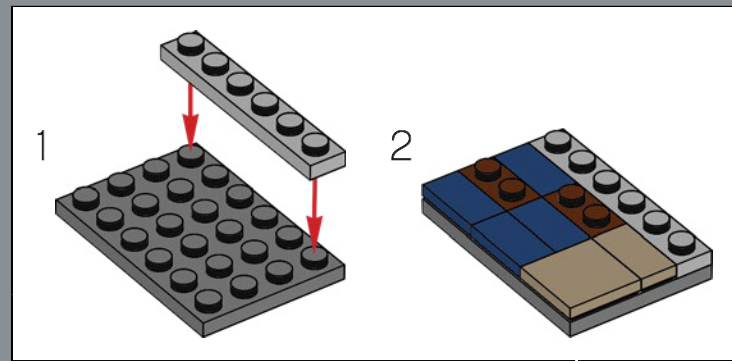

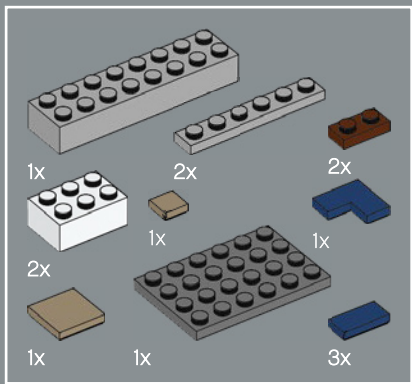

41

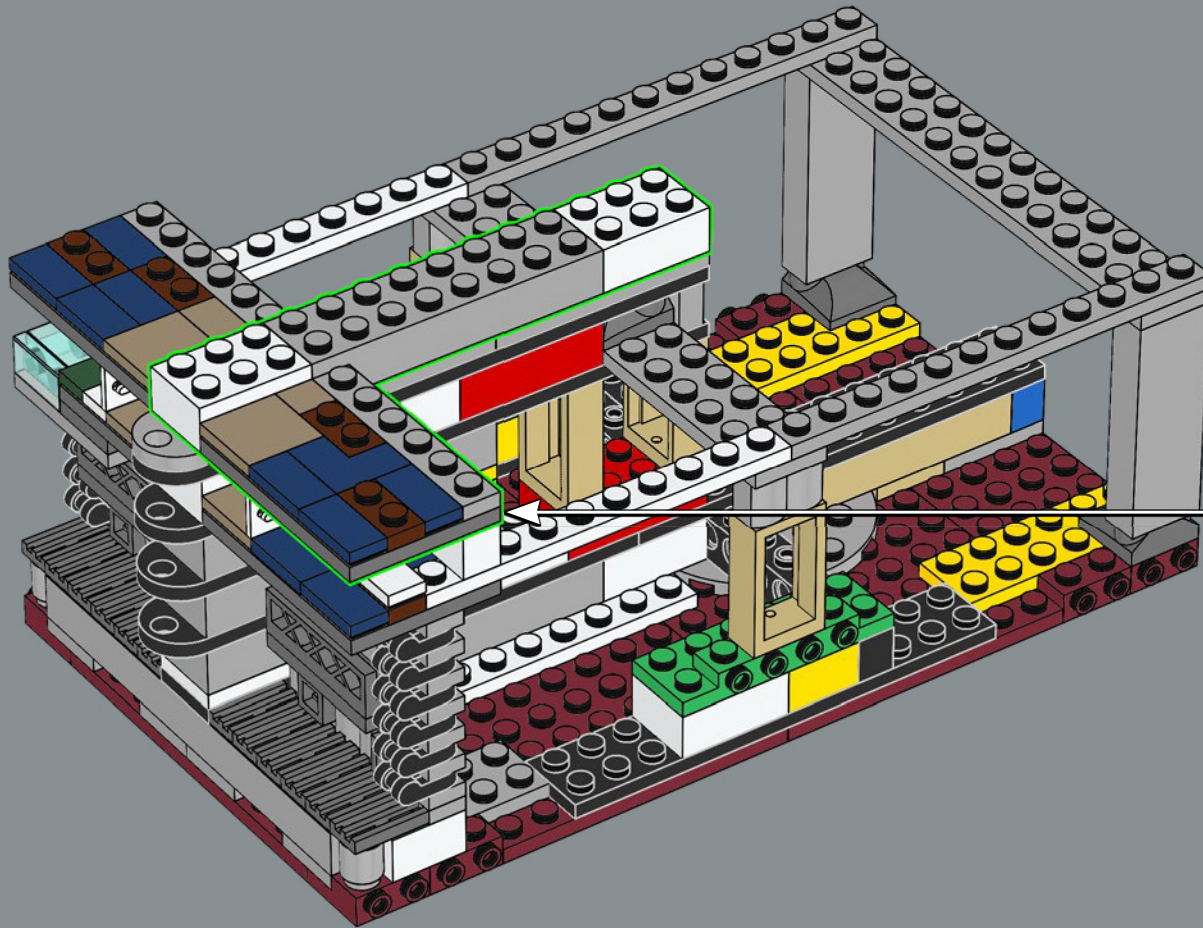
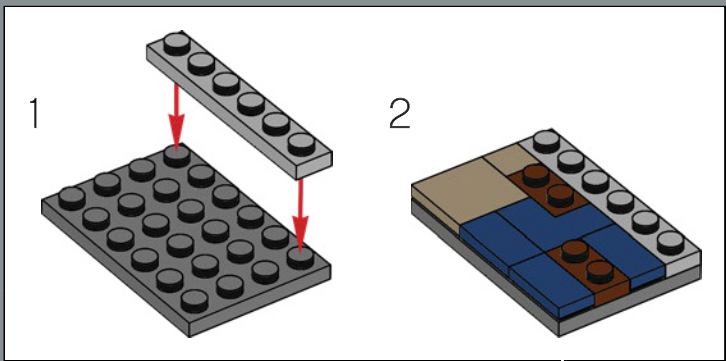

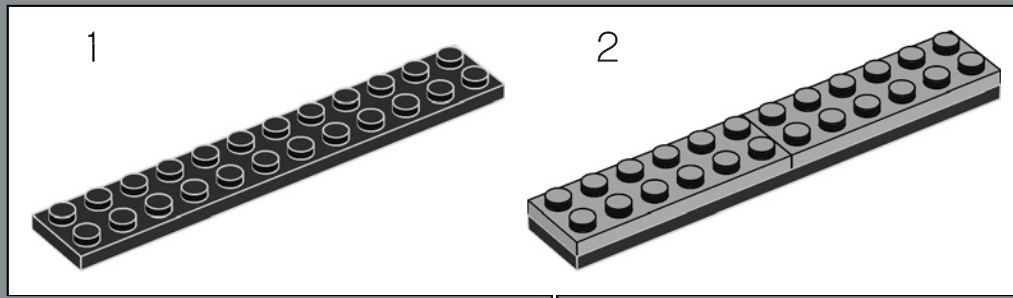
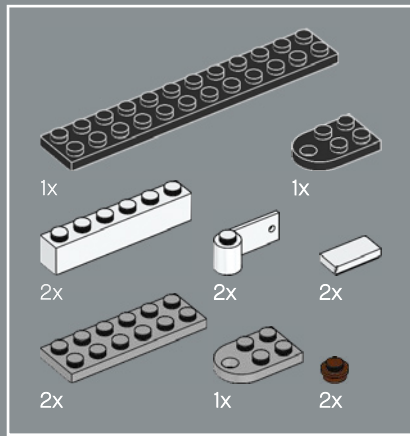

42

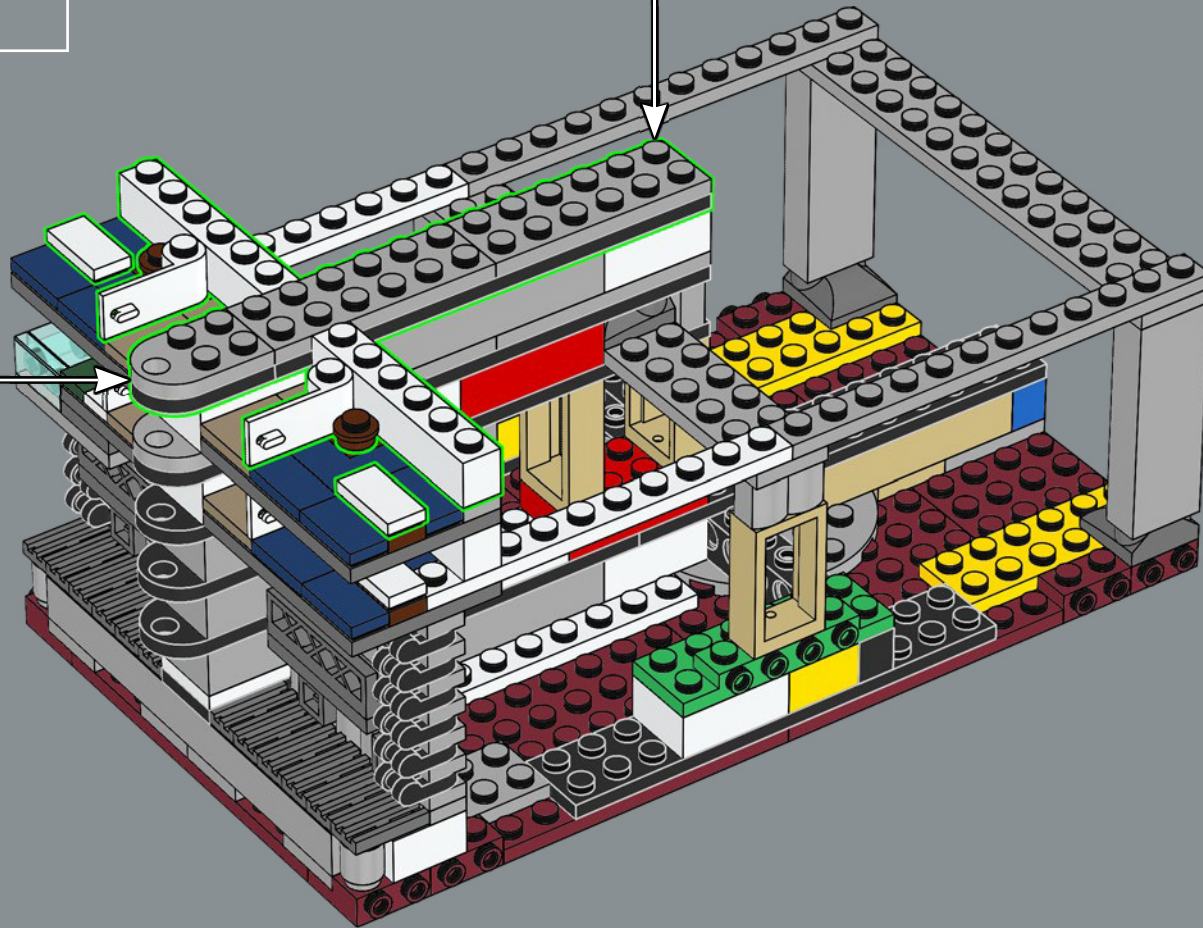
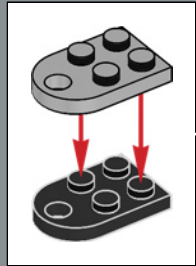

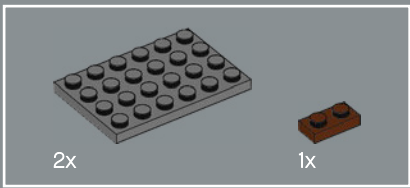

43

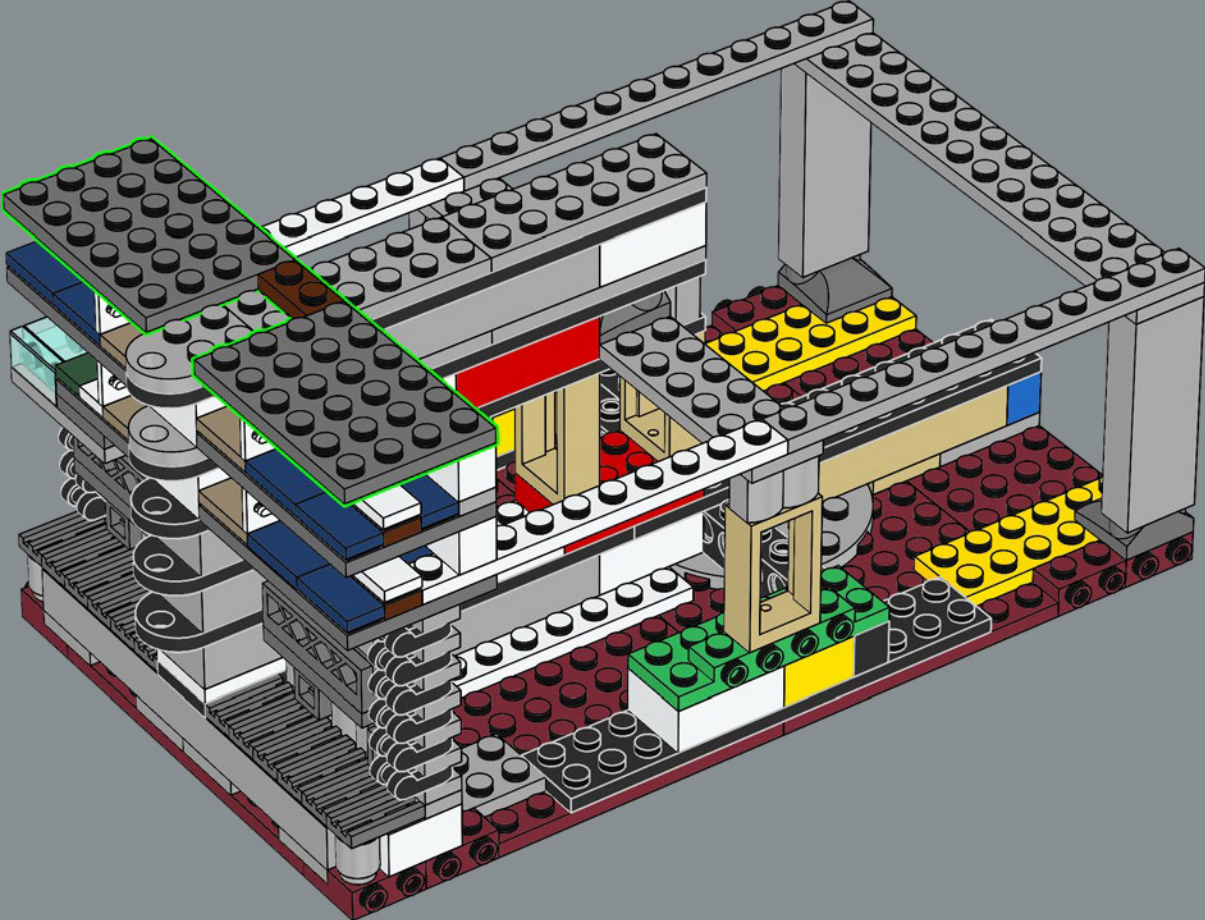

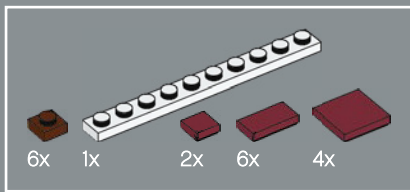

44

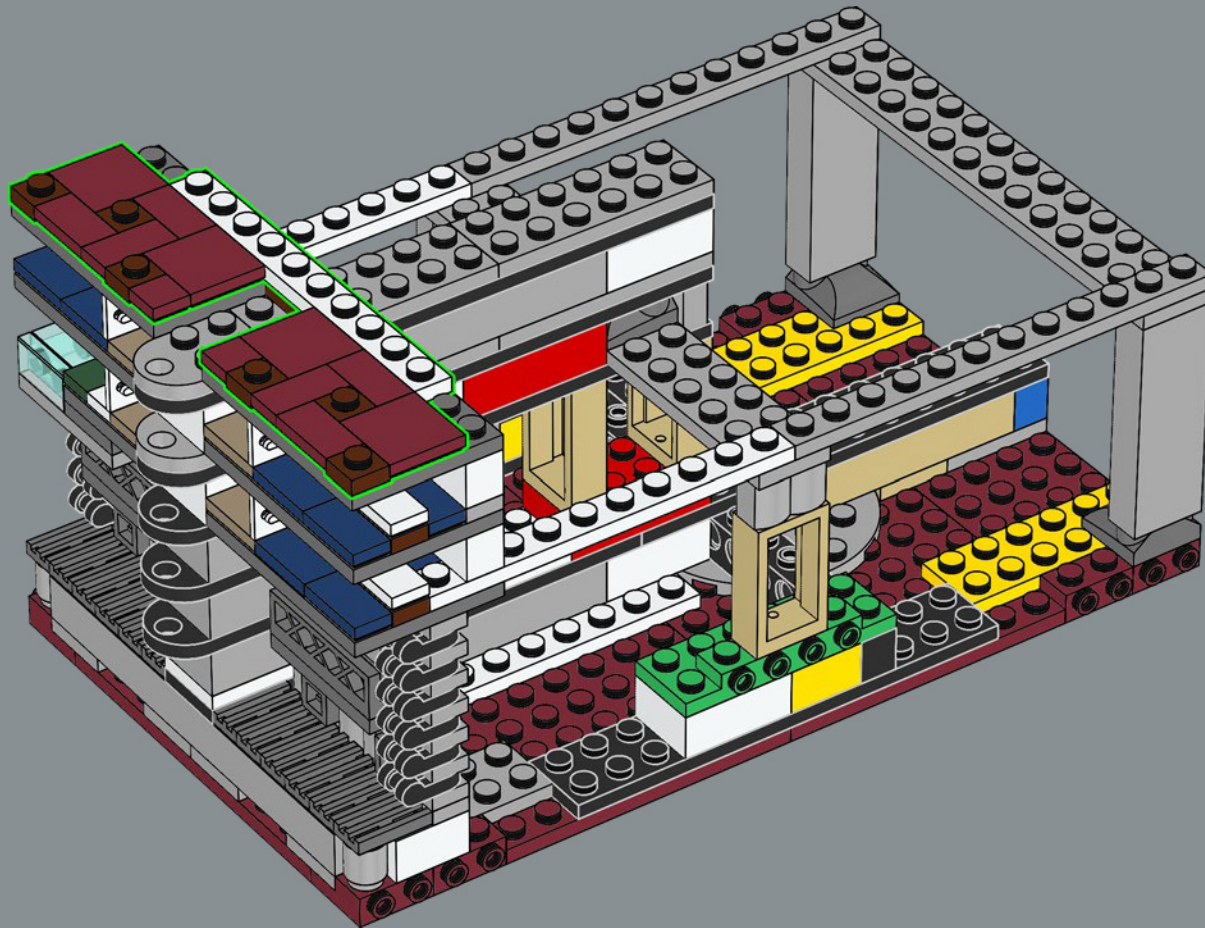

El transatlántico estaba equipado con su propia instalación de abastecimiento de agua, capaz de calentarla y de bombearla a todas las zonas de la nave.

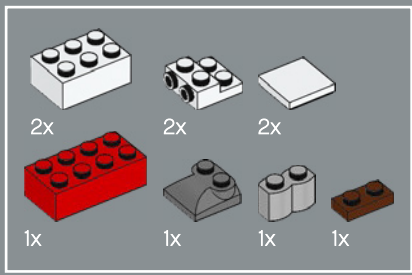

45

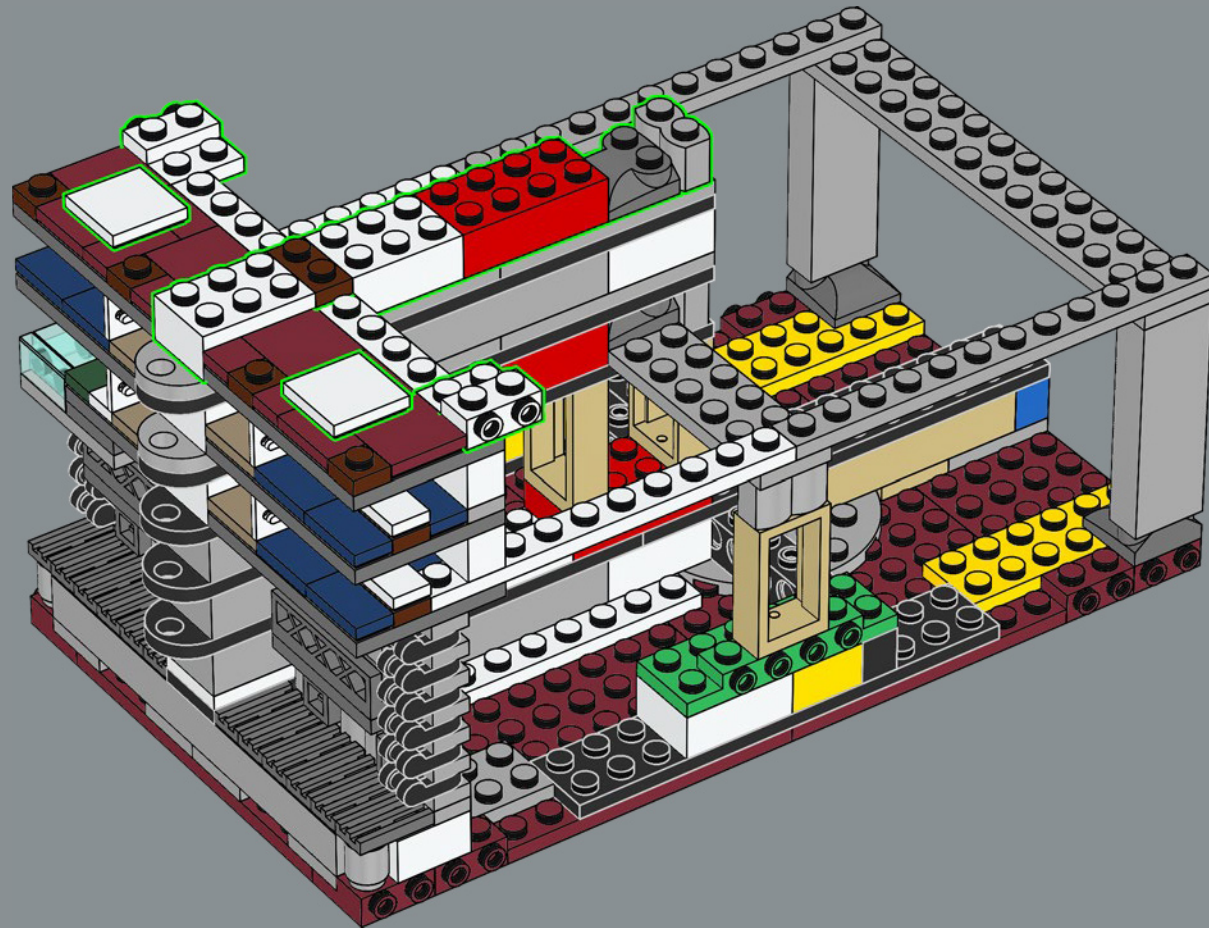

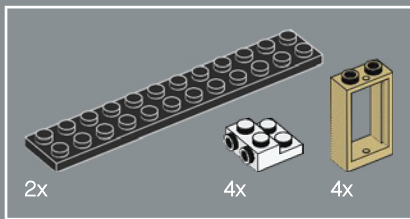

46

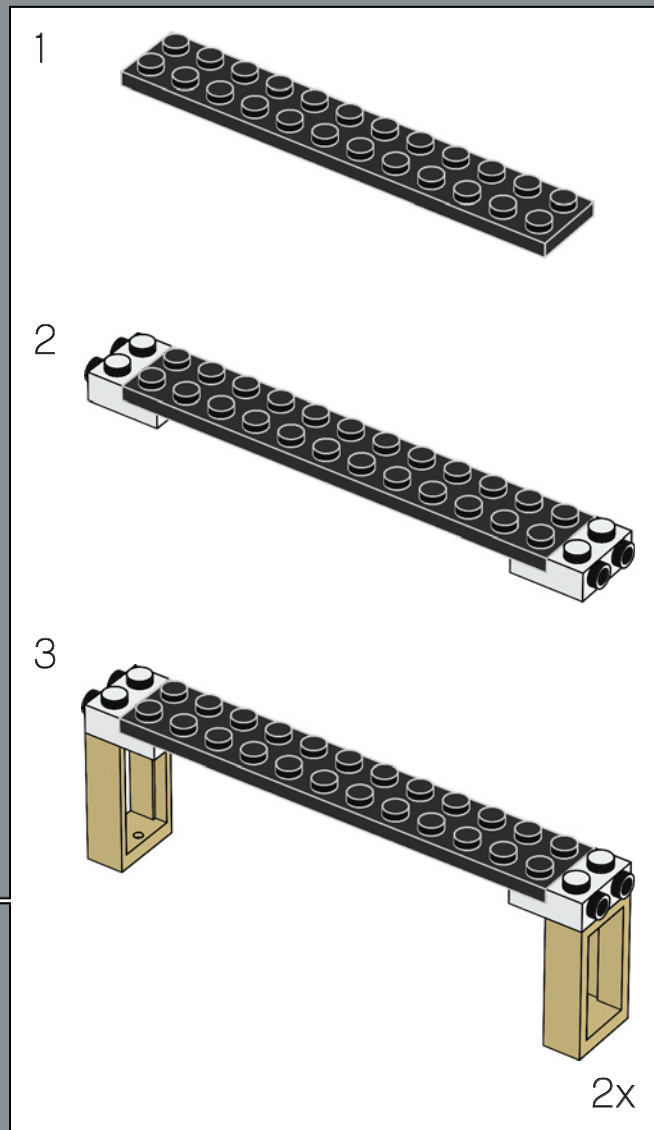
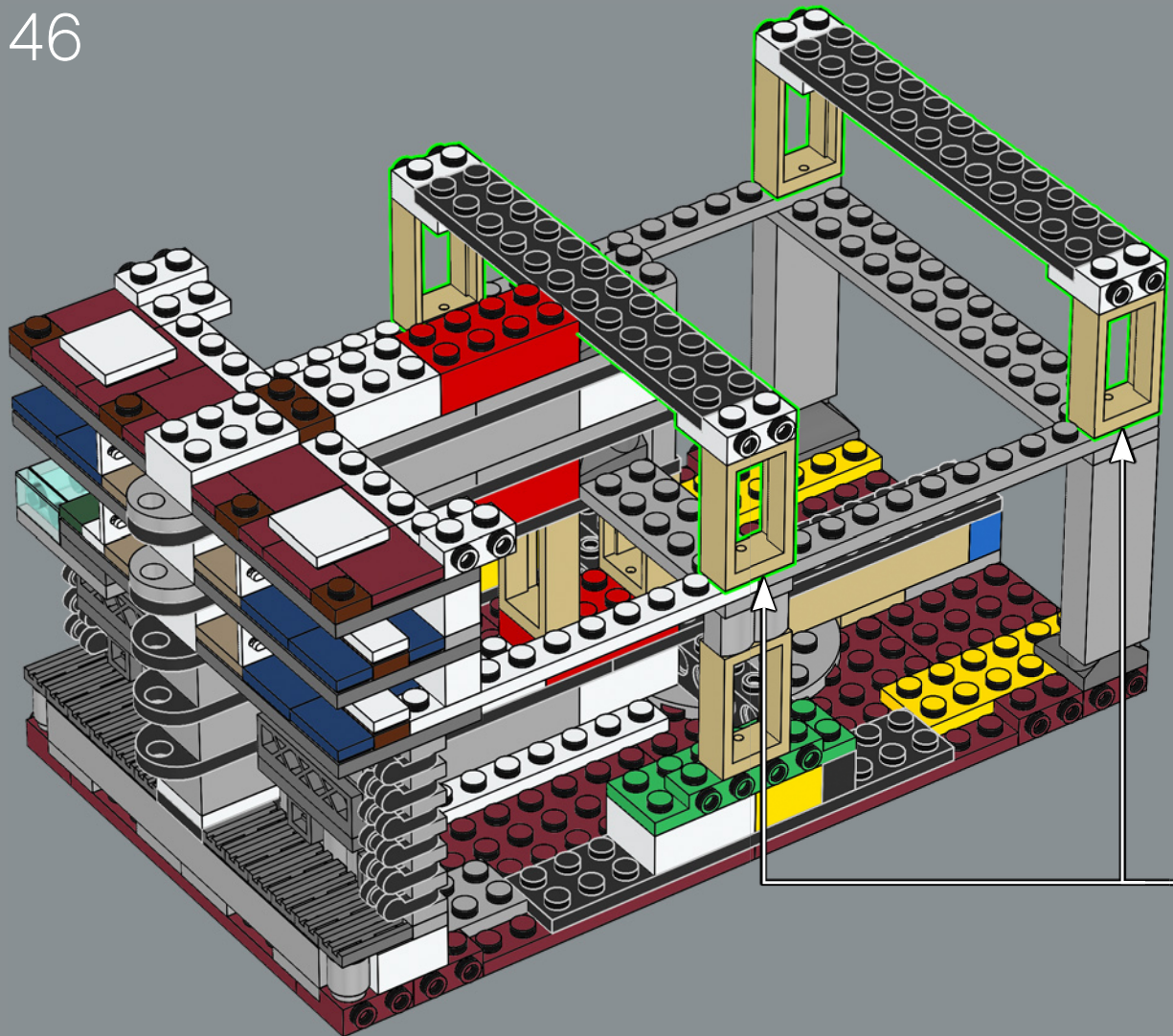

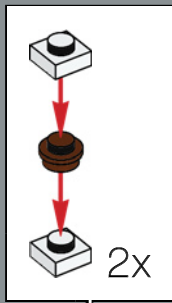
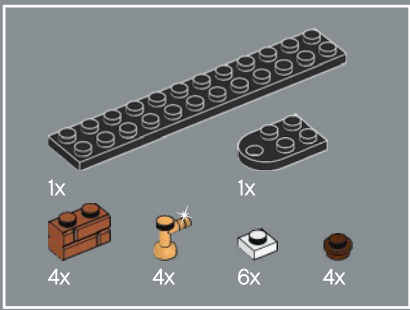

47

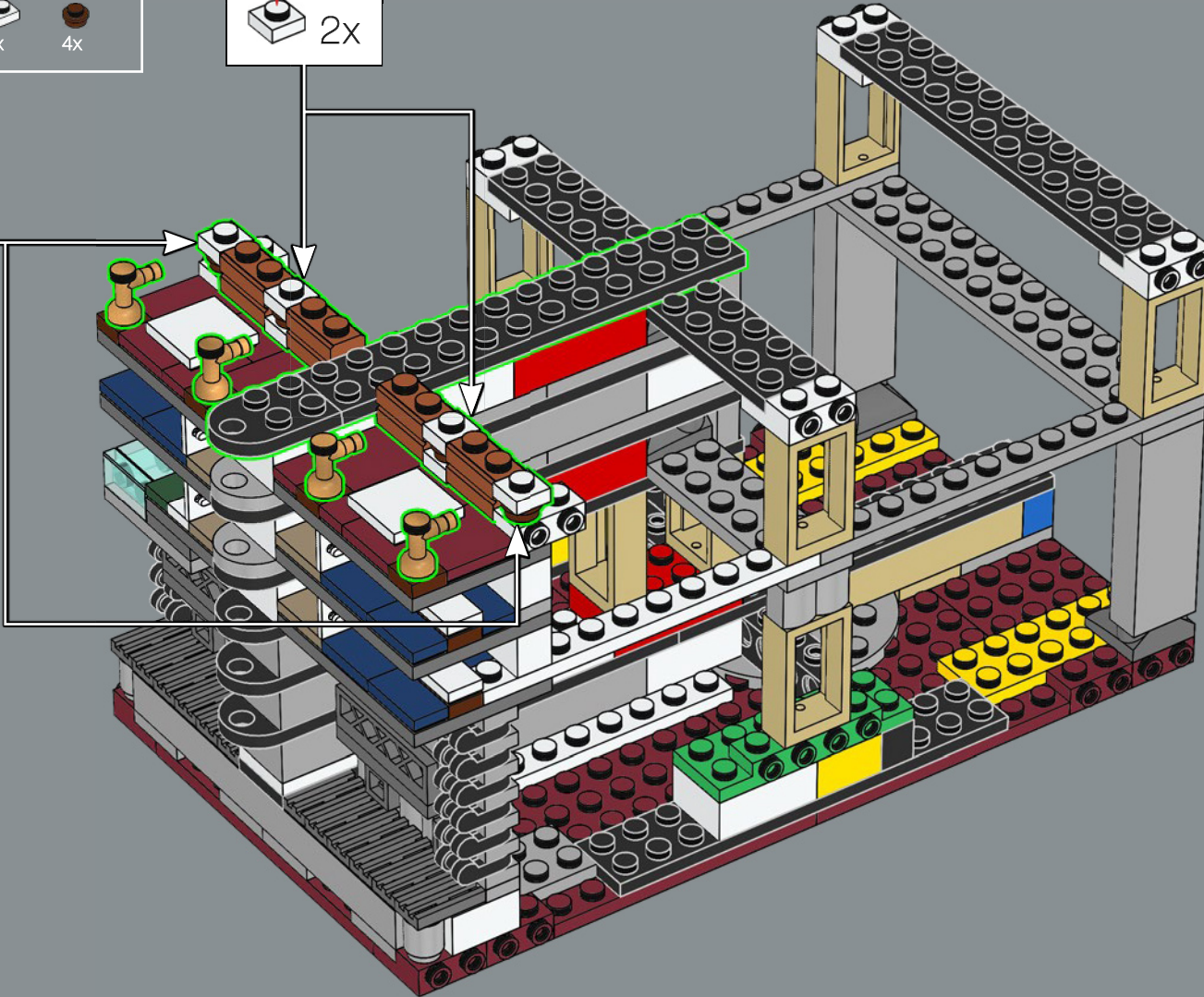
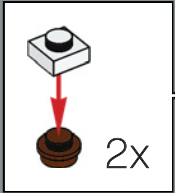

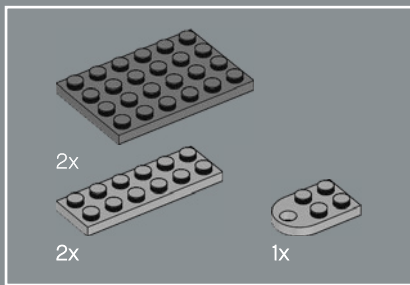

48

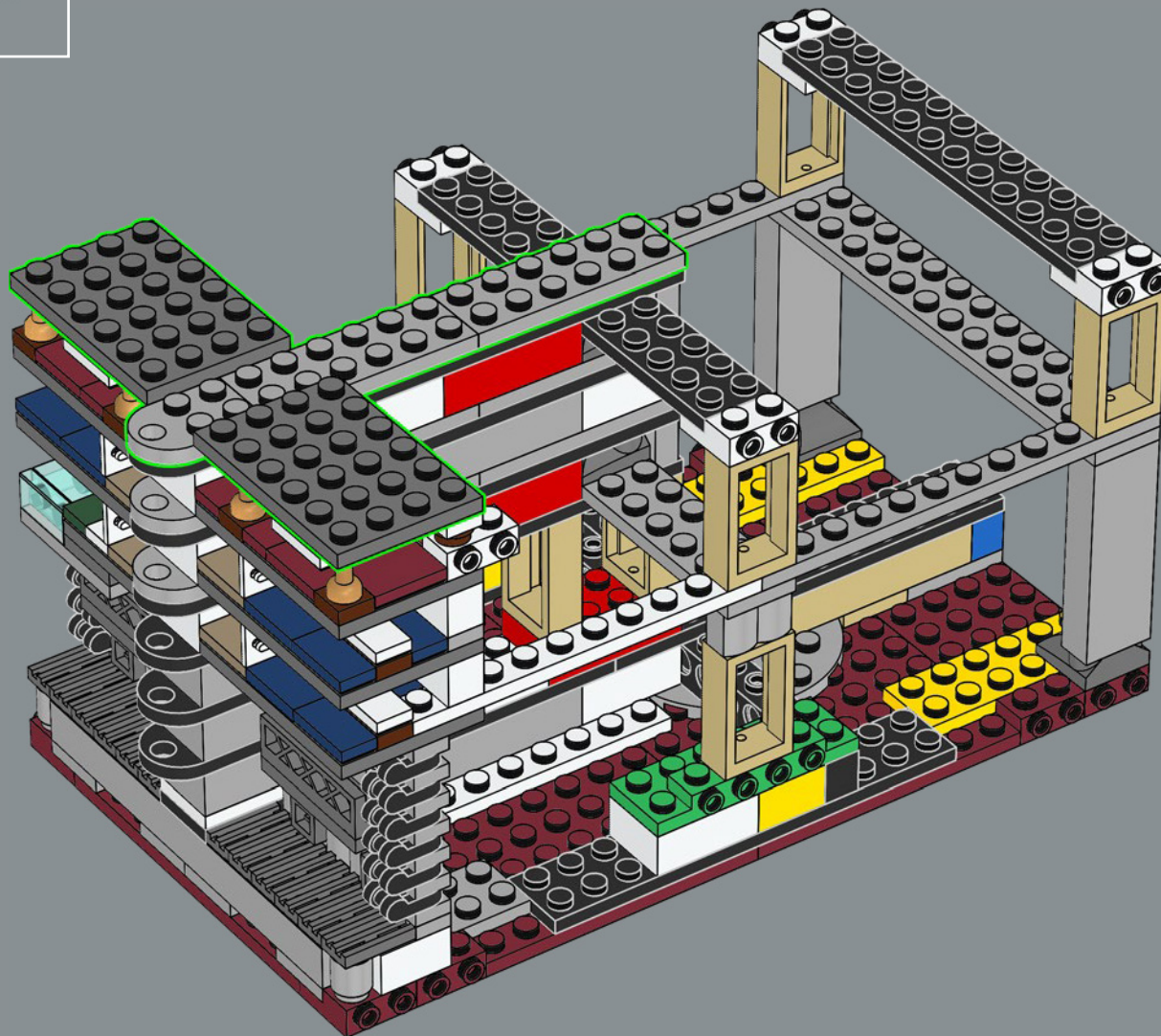



49

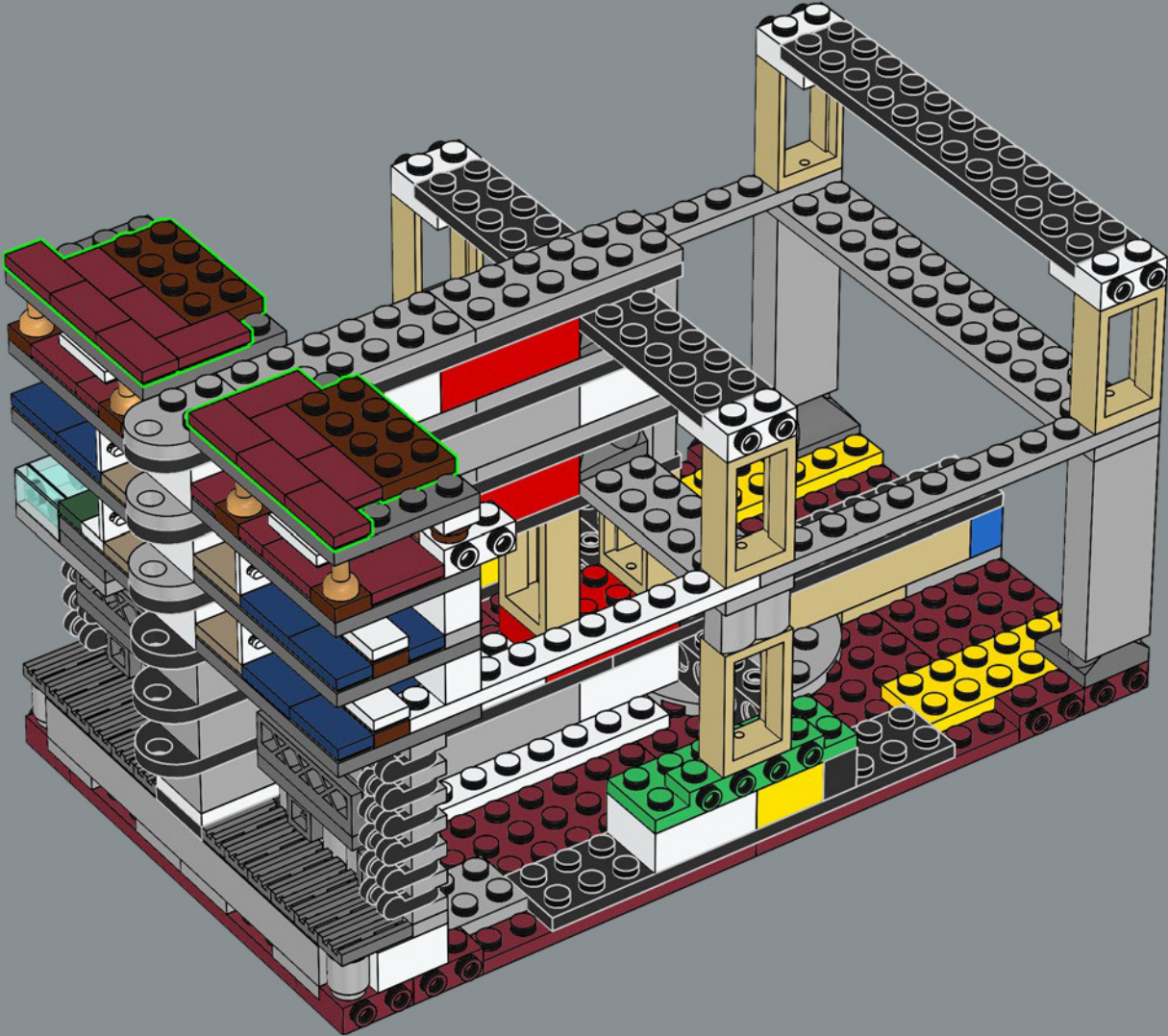

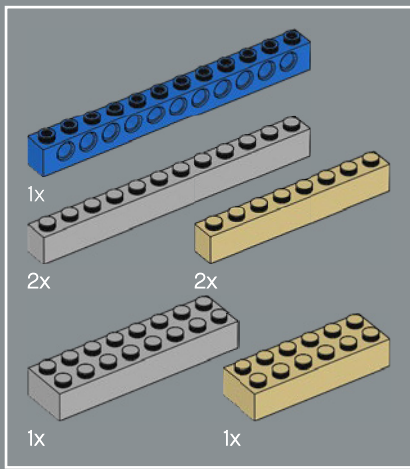

50

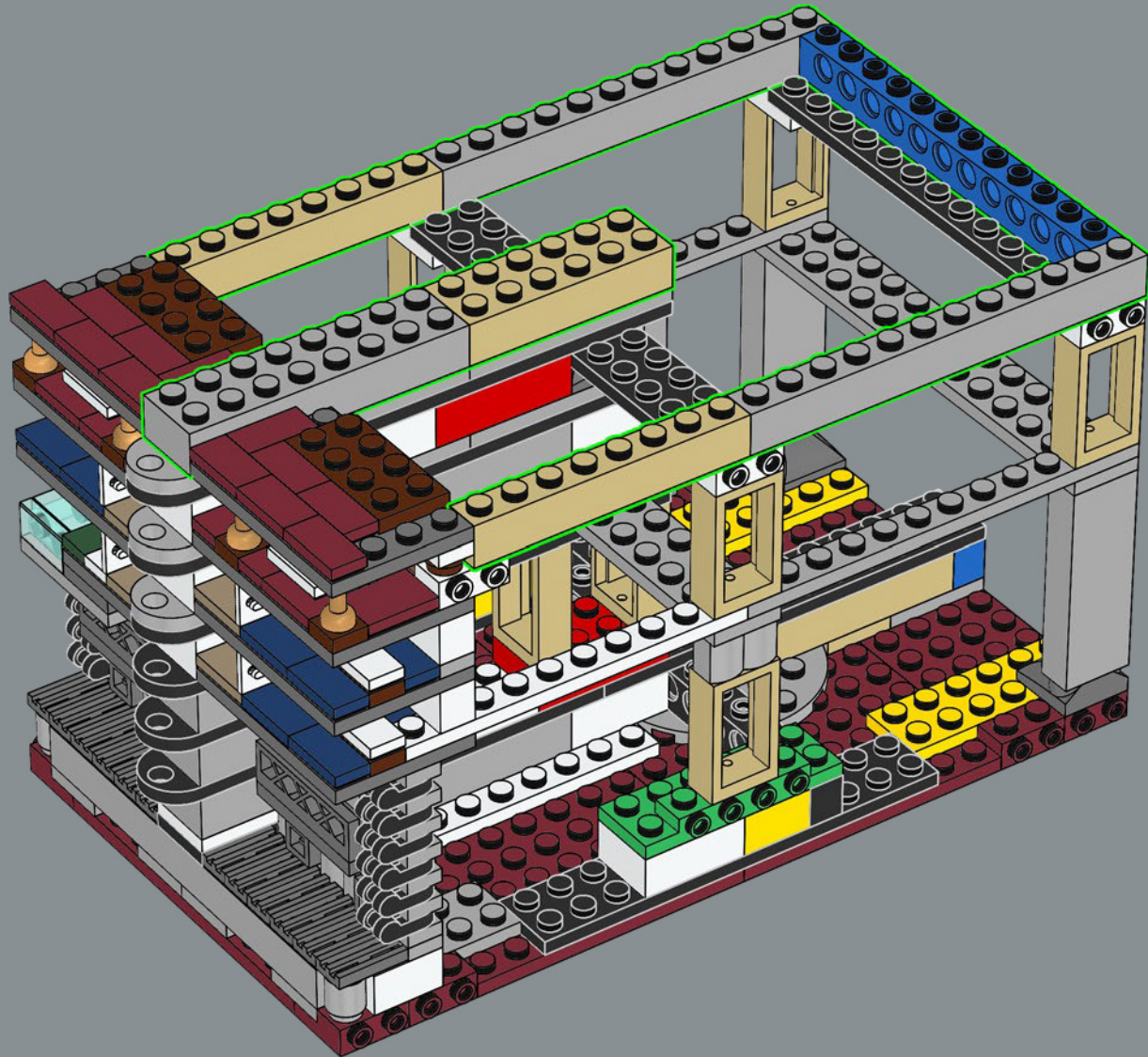

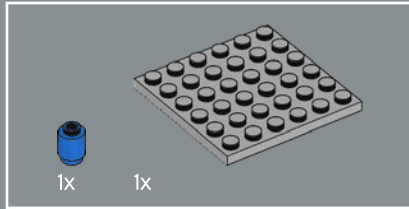
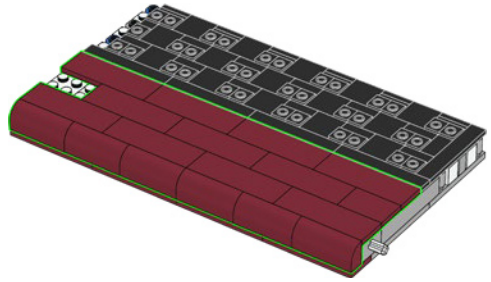
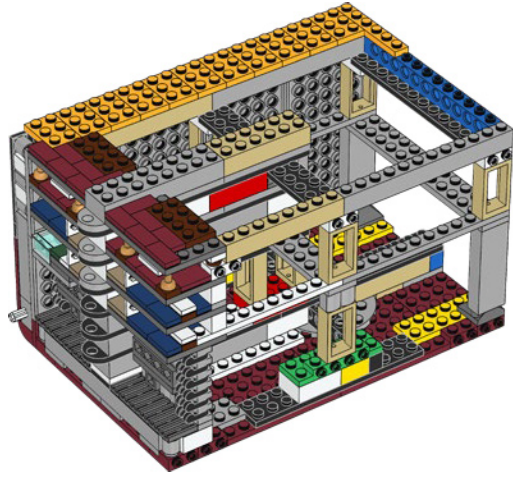
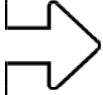

51

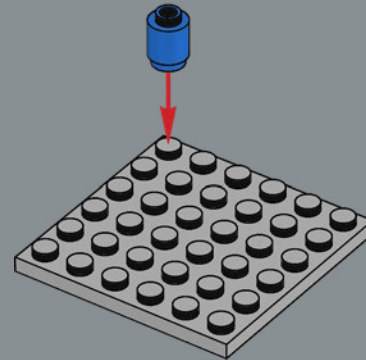

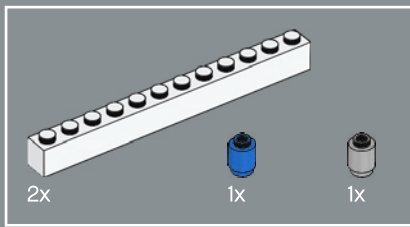

52

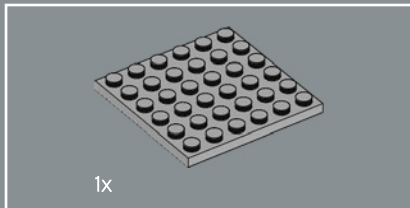
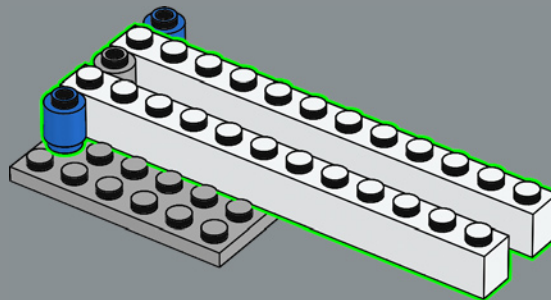

53

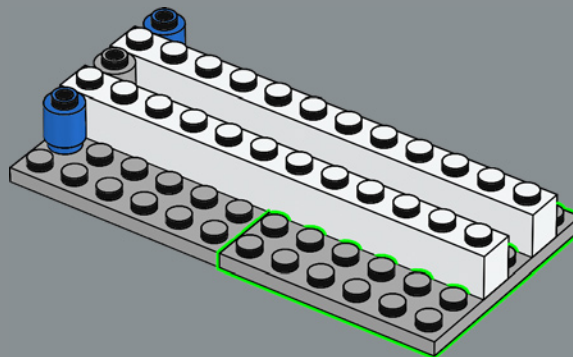

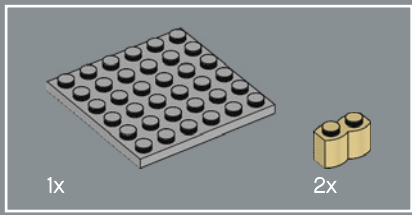

54

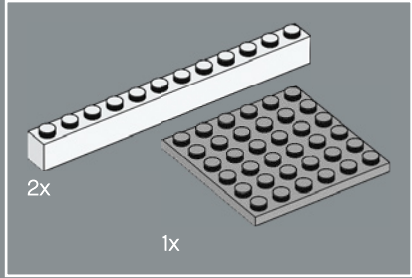
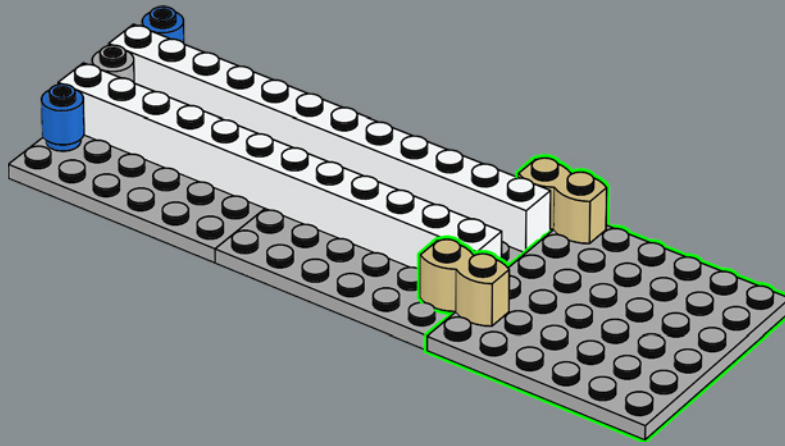

55

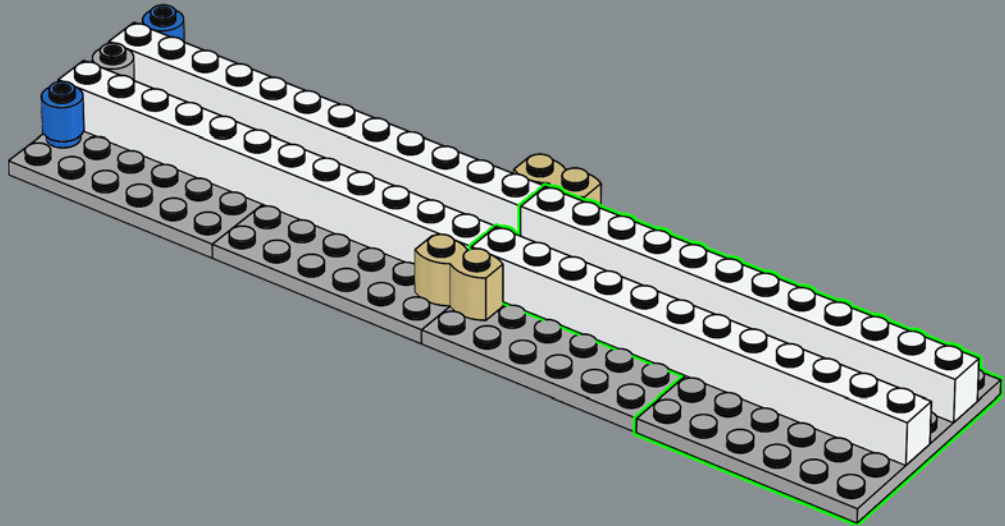

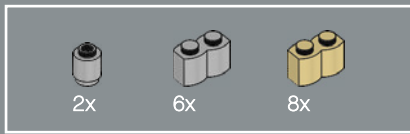

56

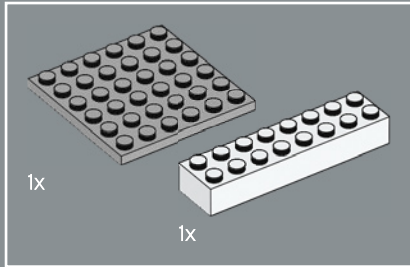
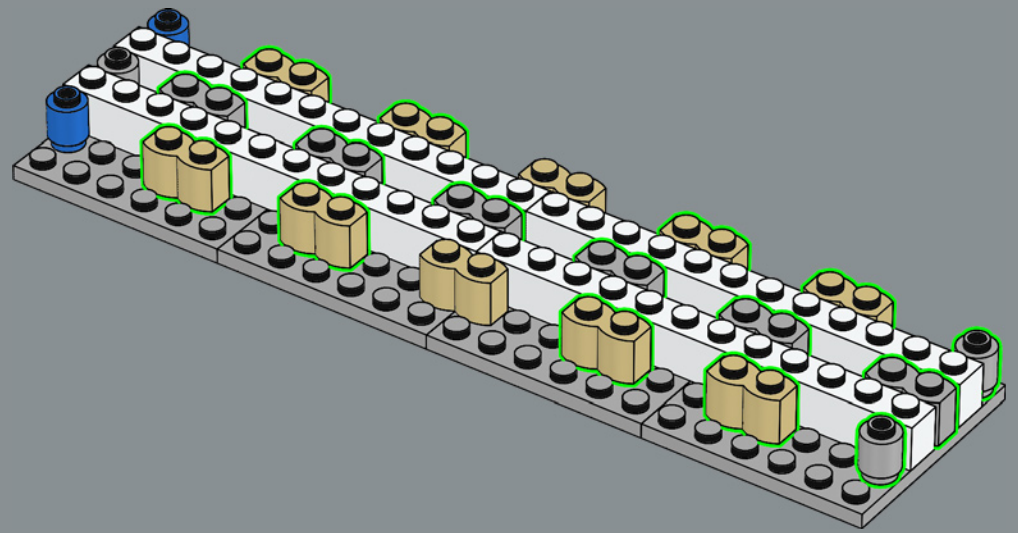

57

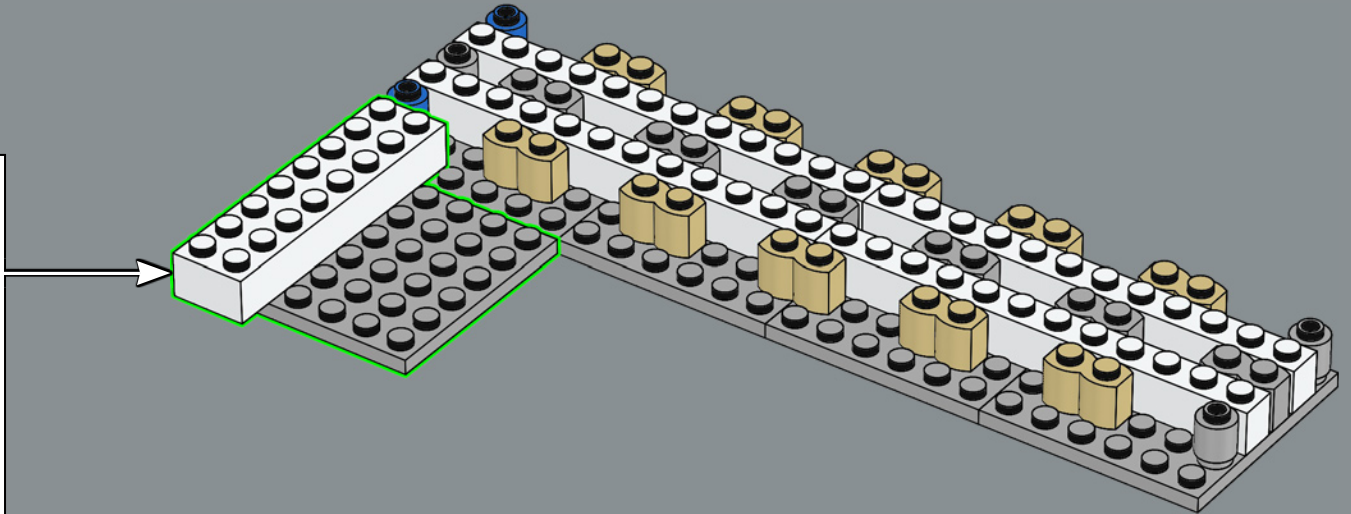
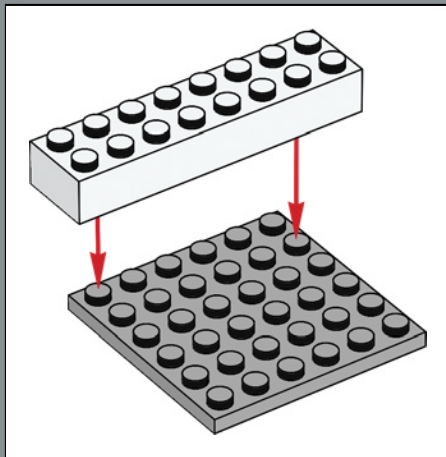

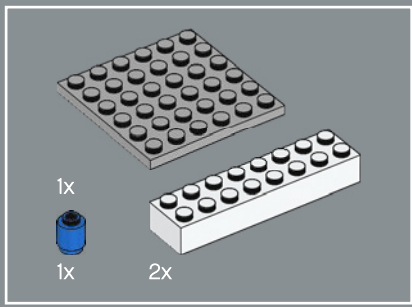

58

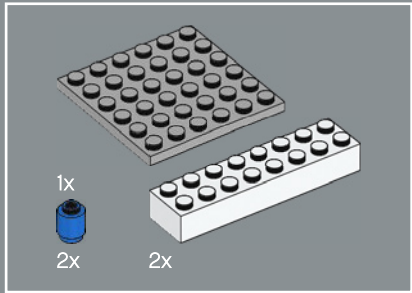
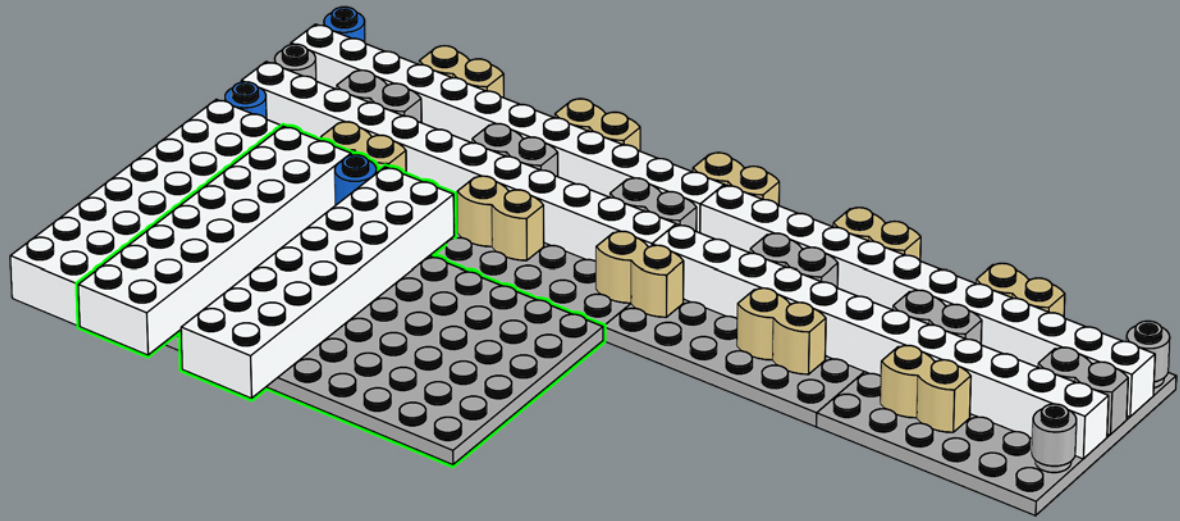

59

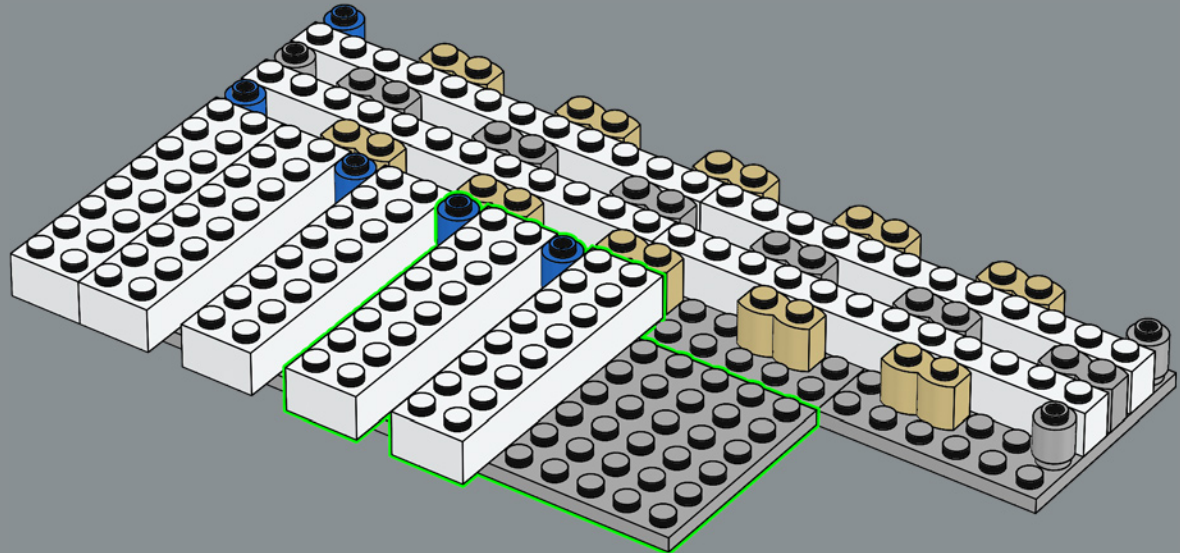

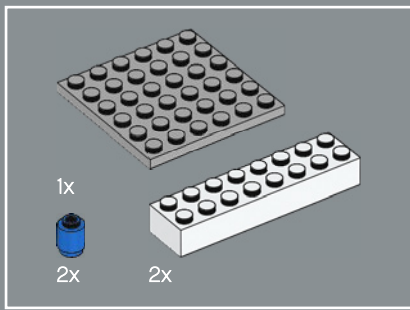

60

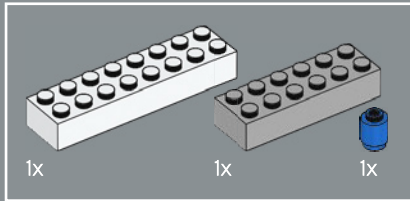
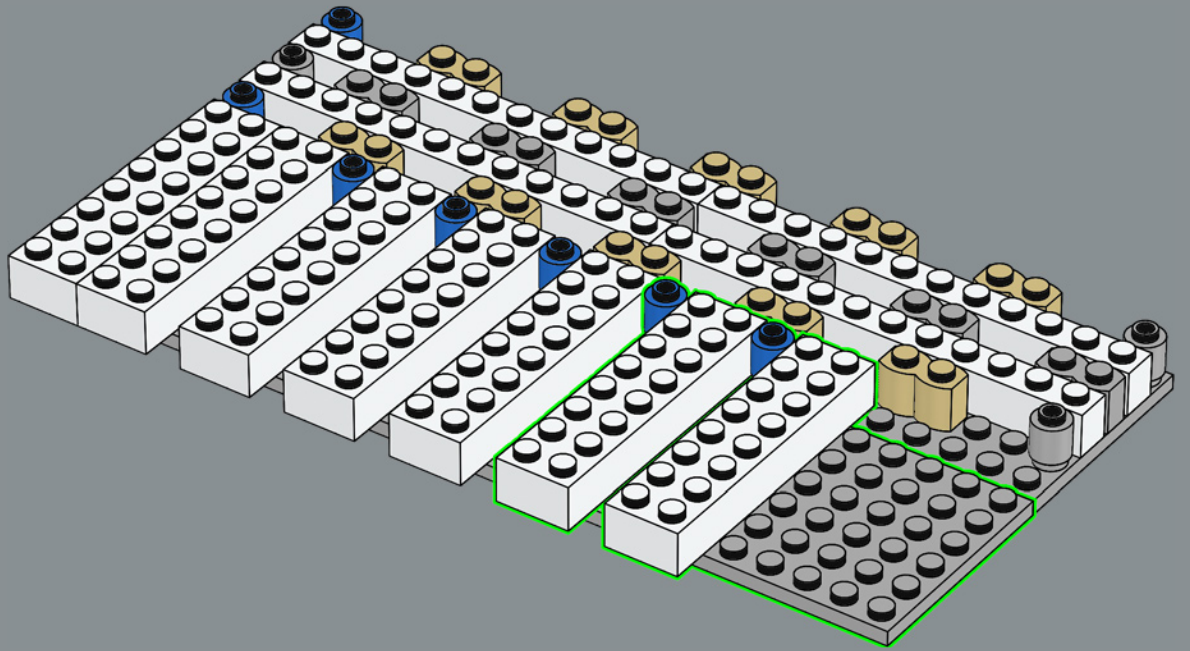

61

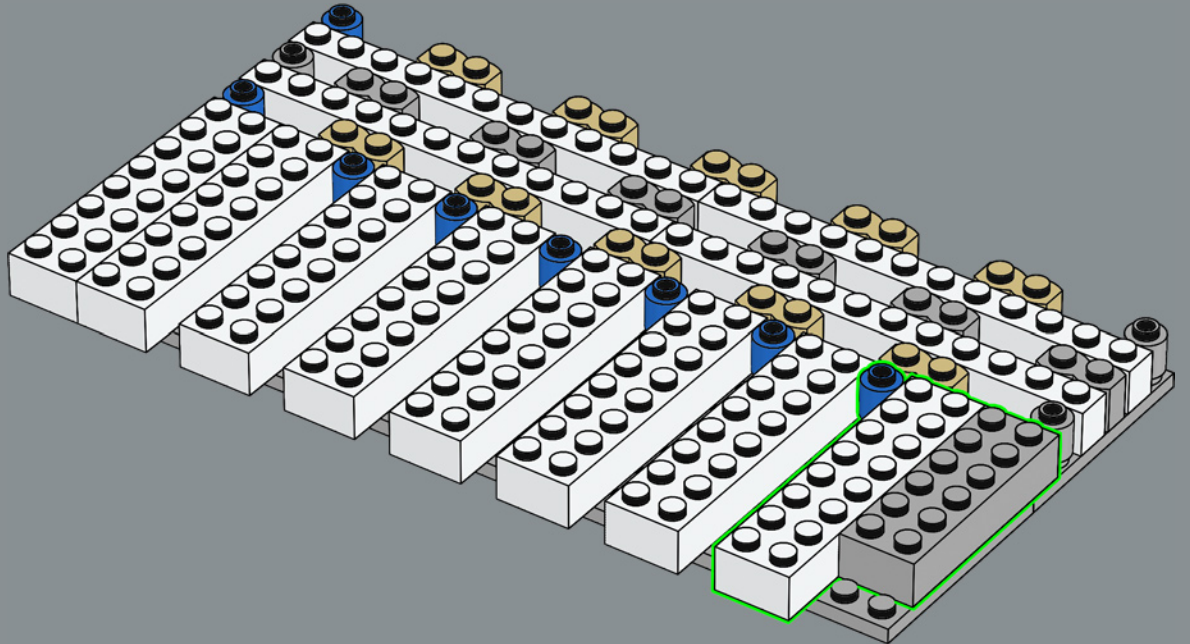

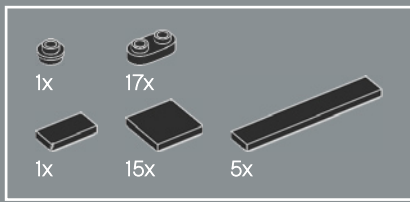

62

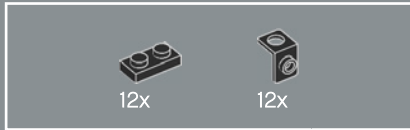
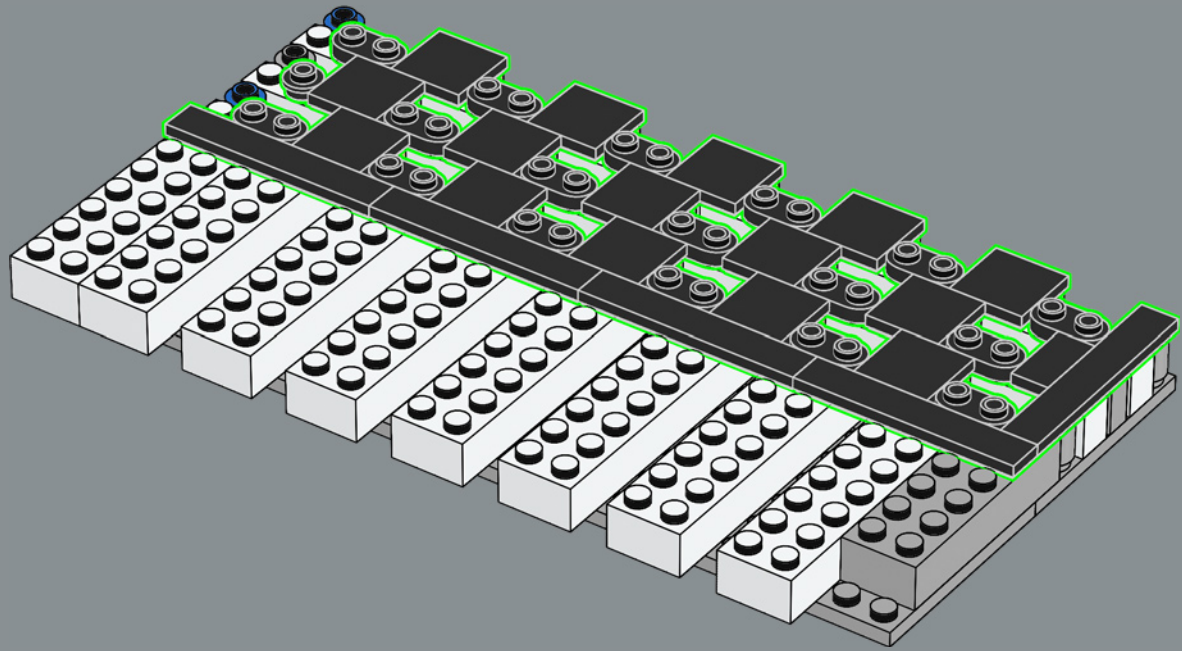

63

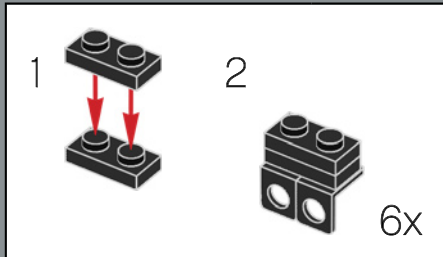
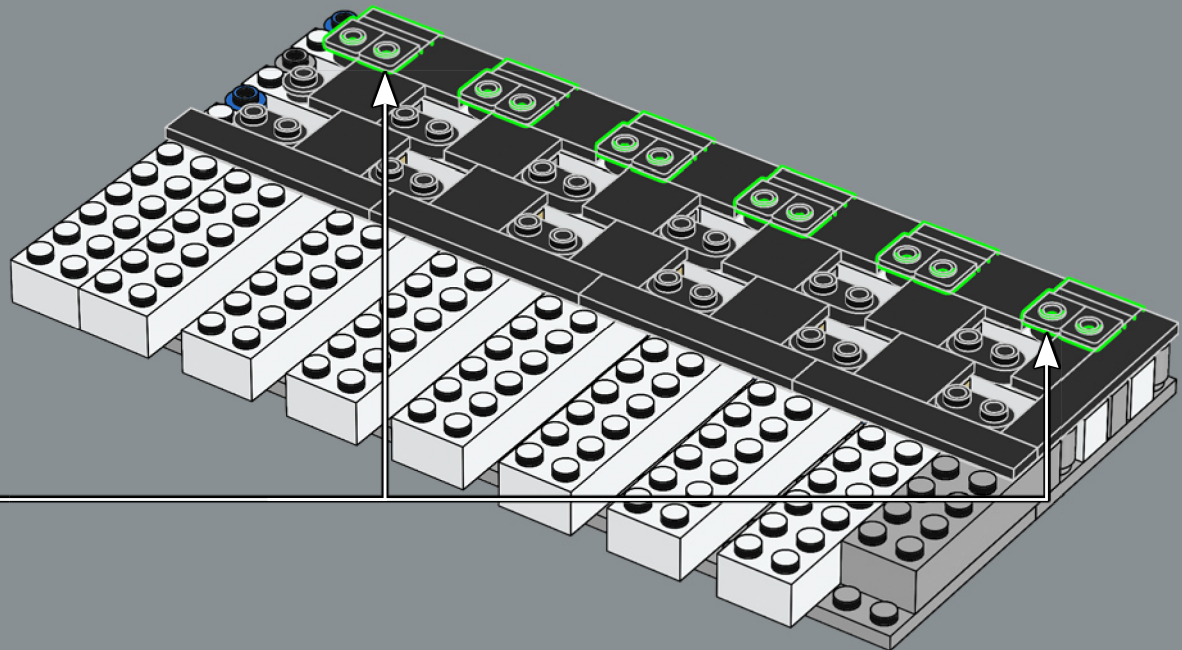

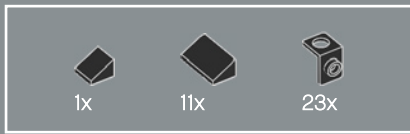

64

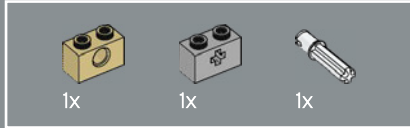
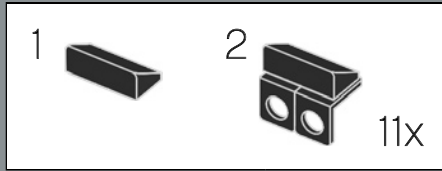
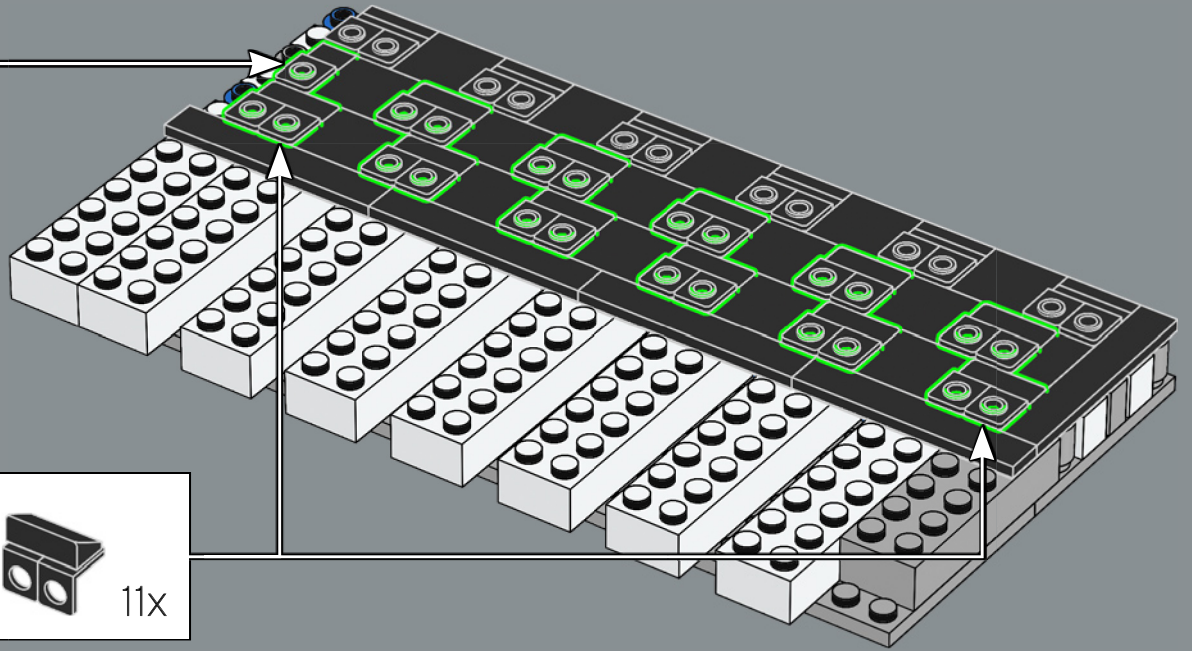
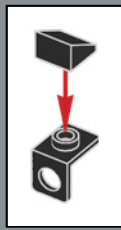

65

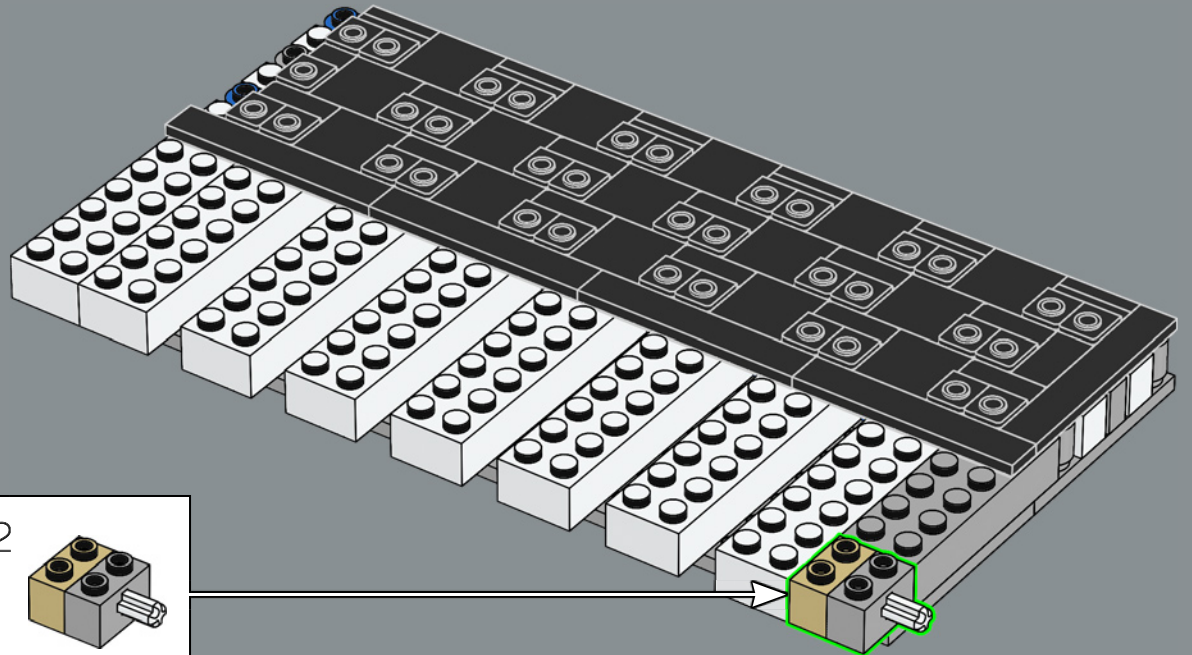
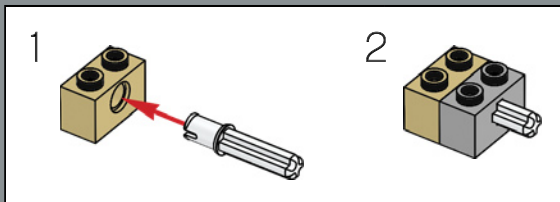

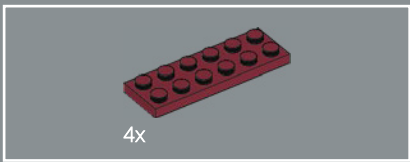

66

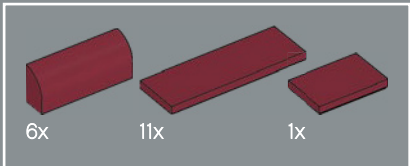
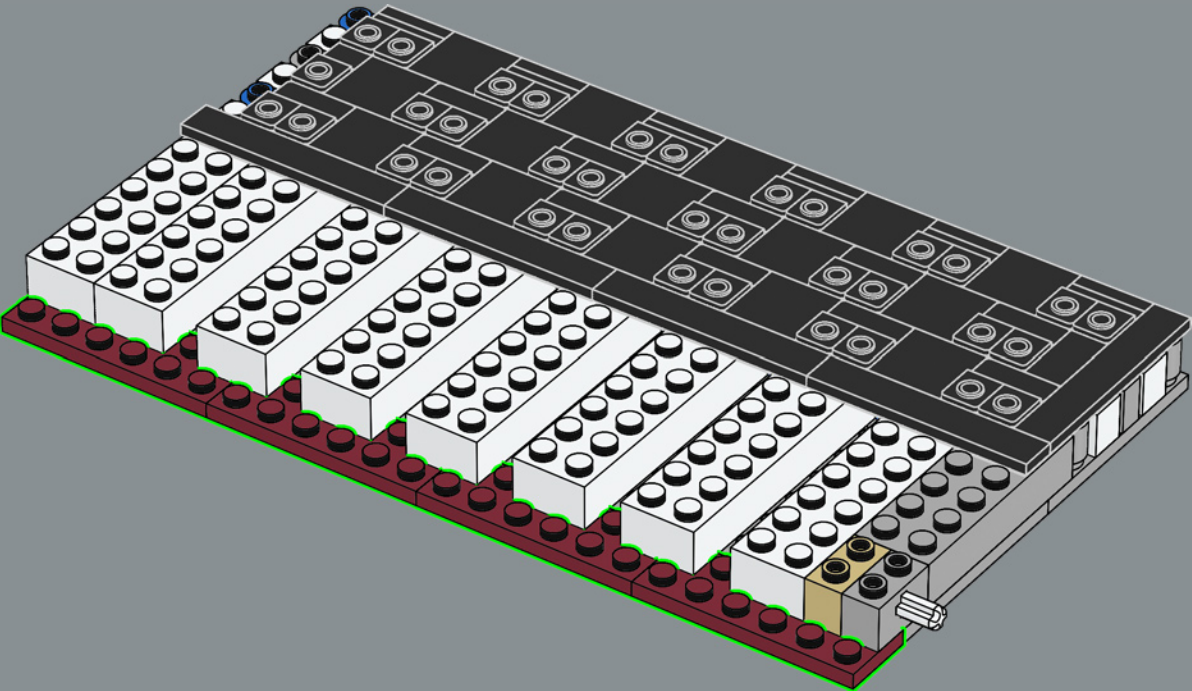

67

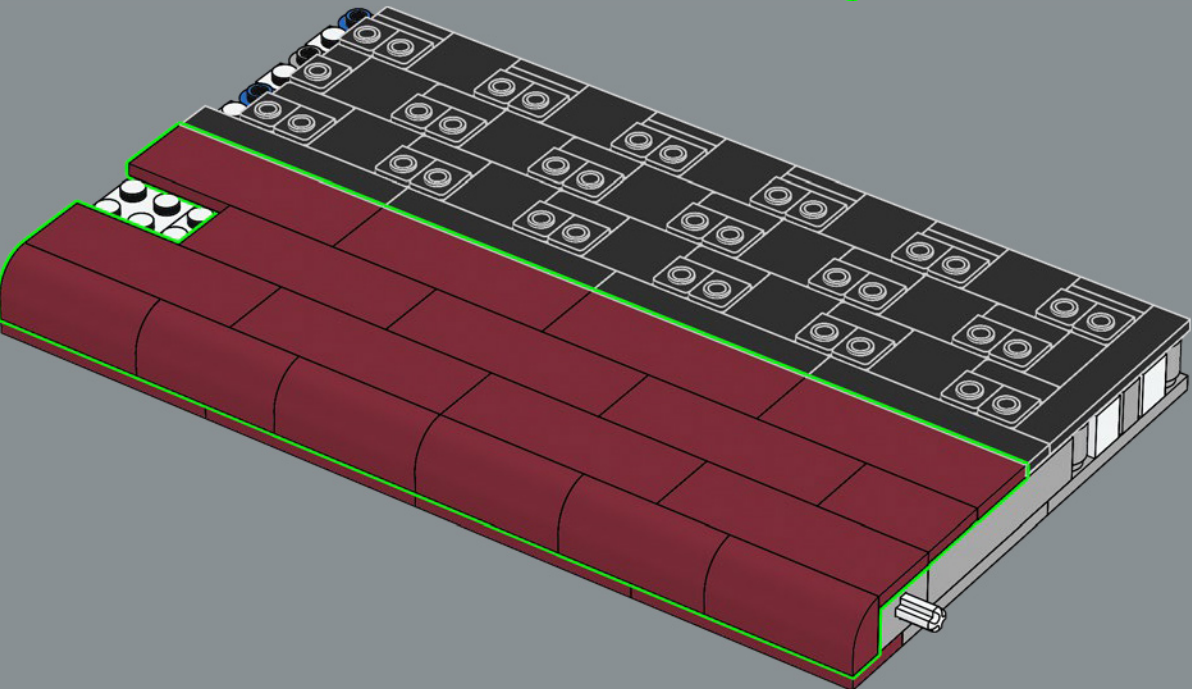

68

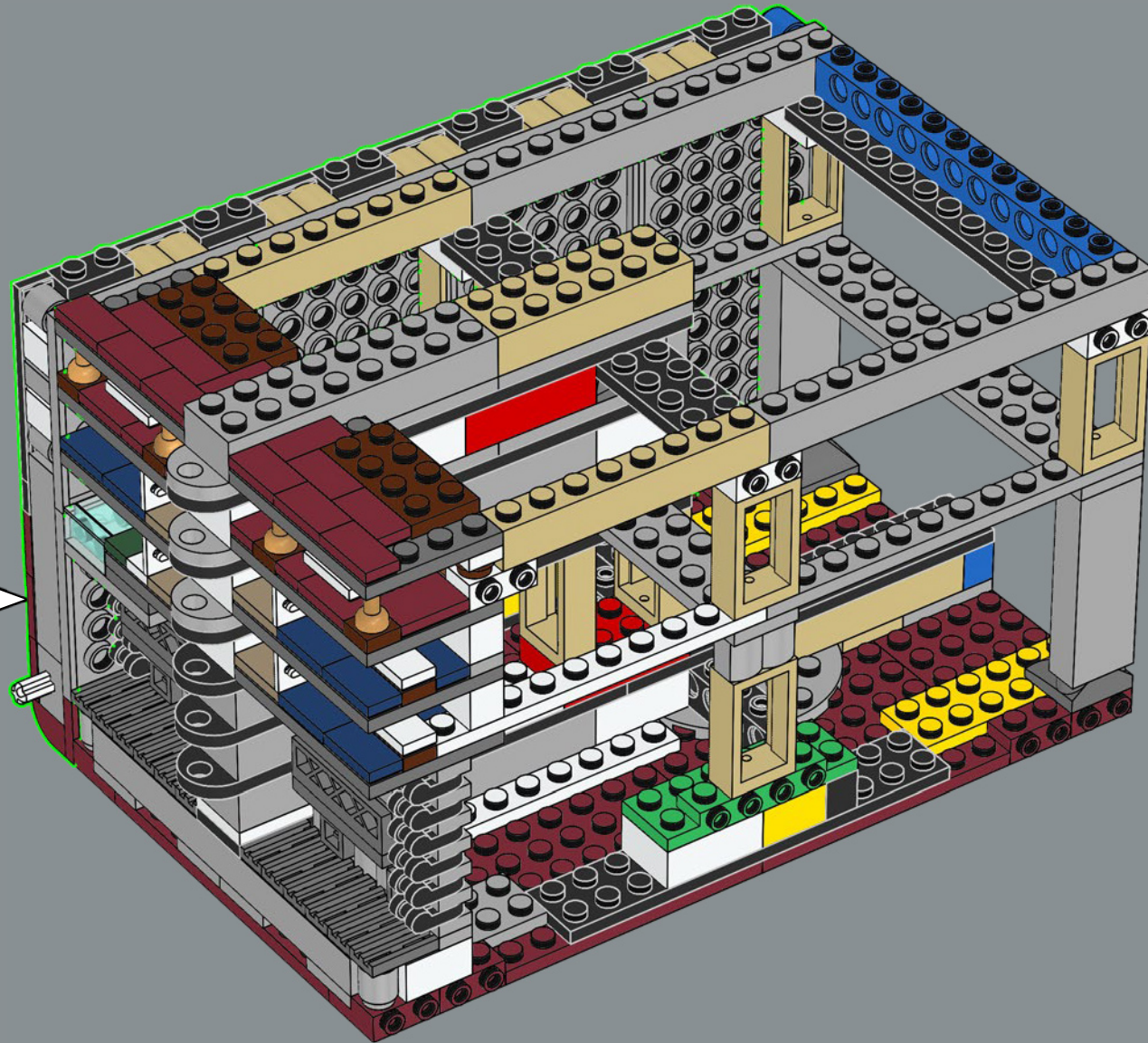

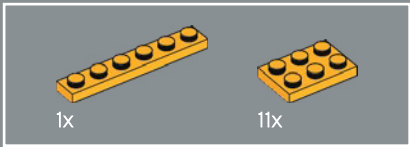

69

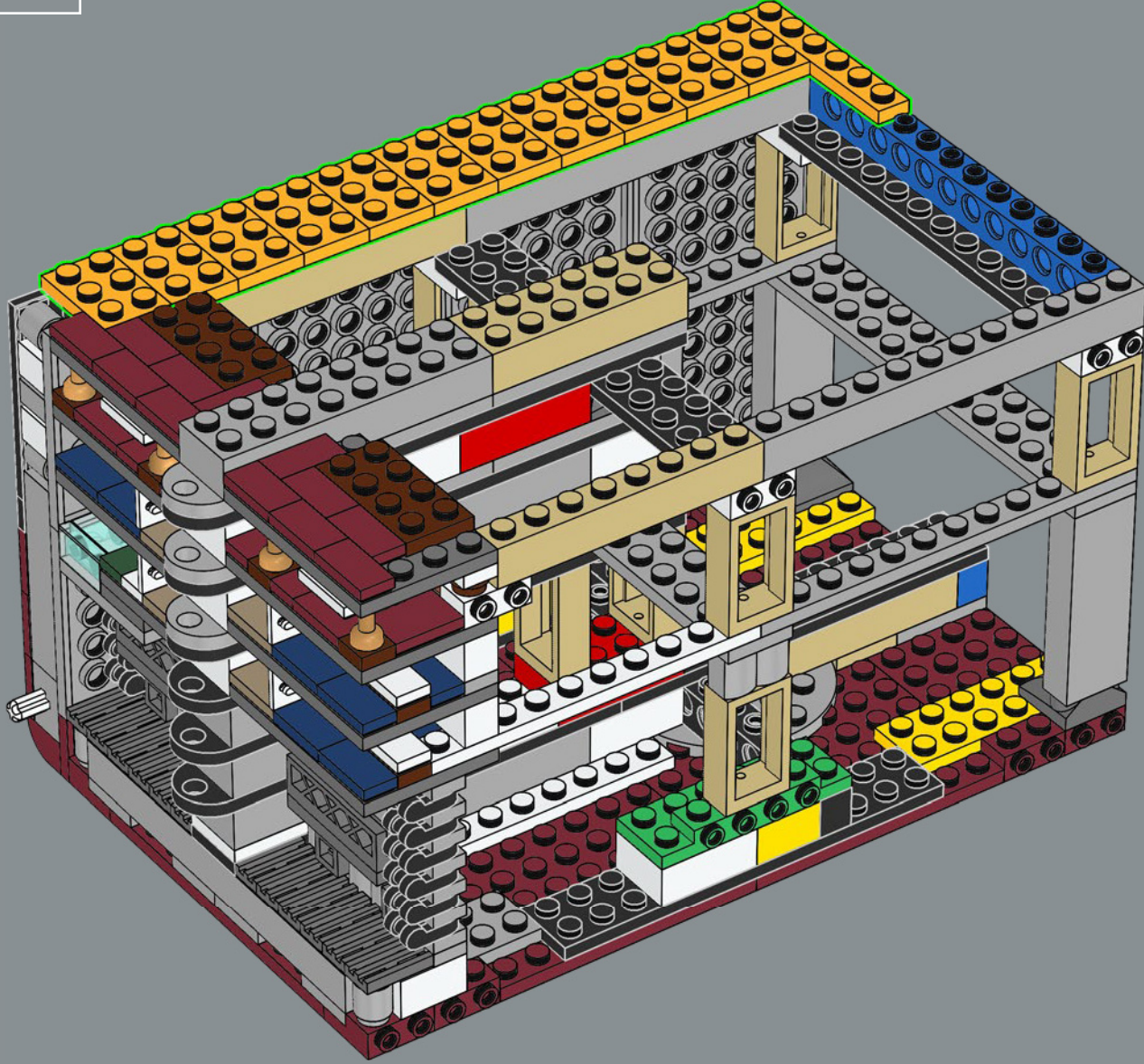

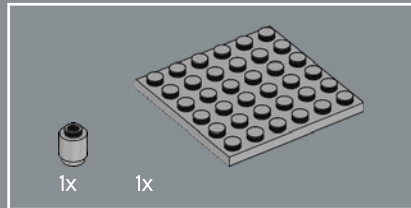
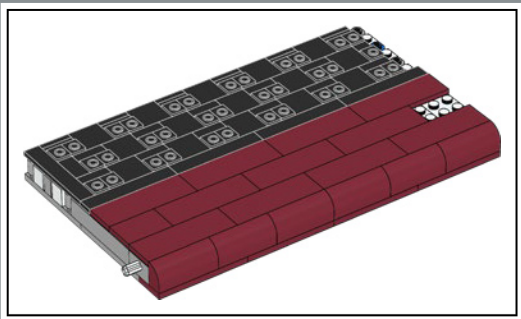
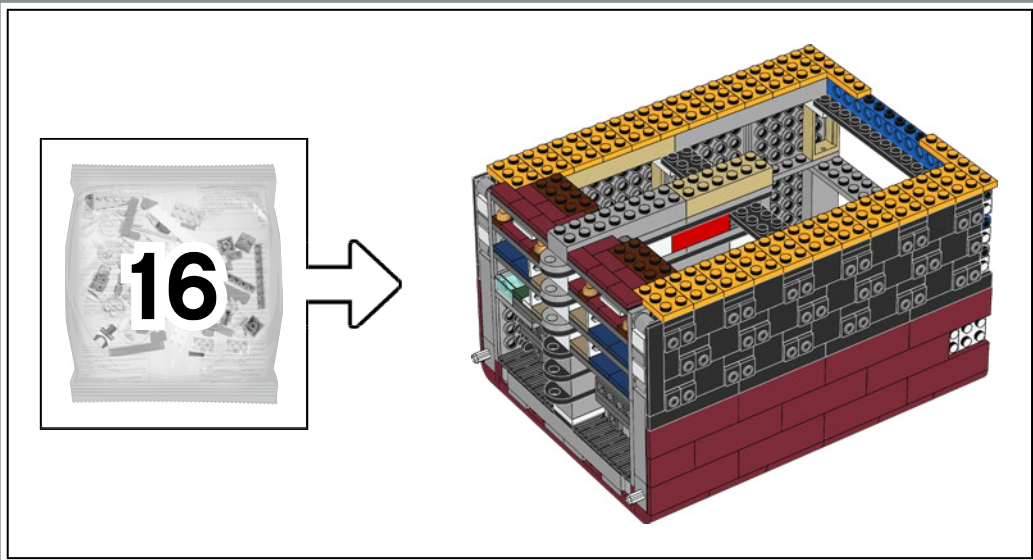

70

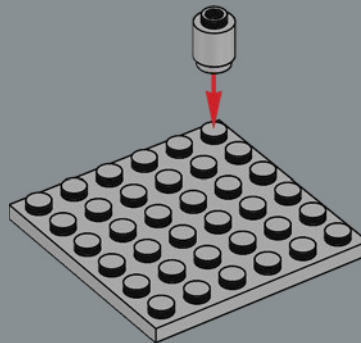

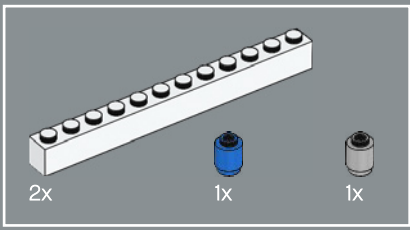

71

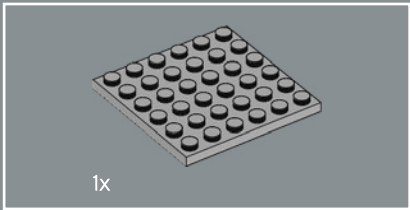
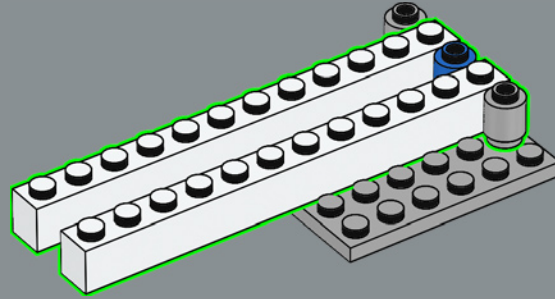

72

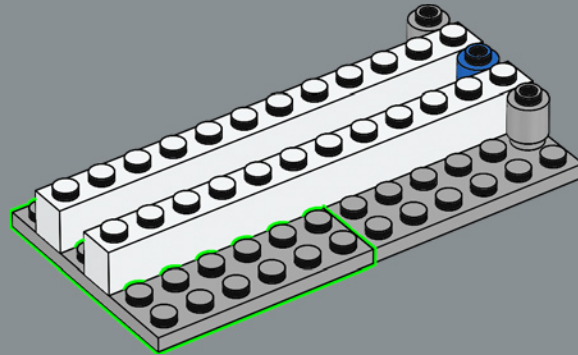

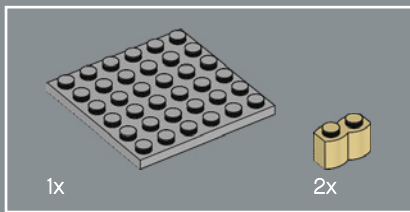

73

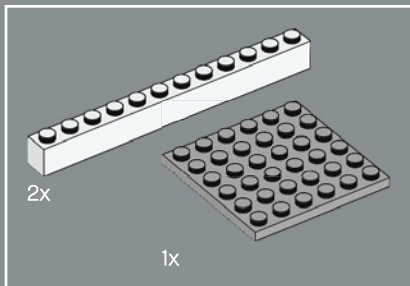
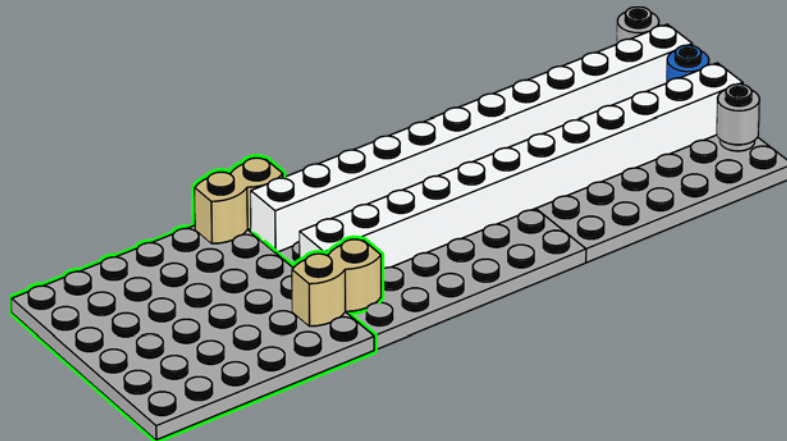

74

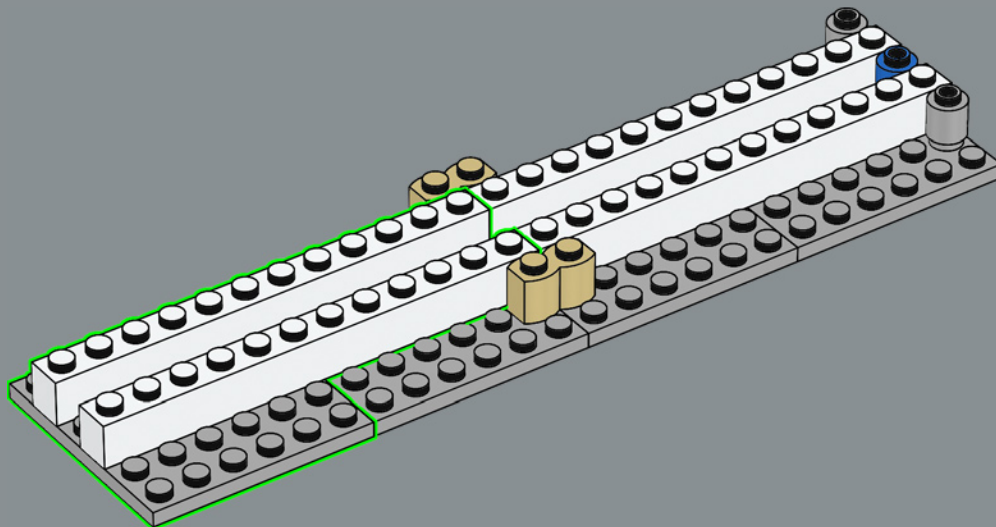

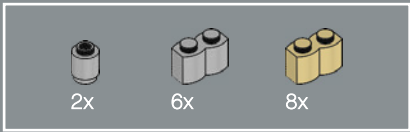

75

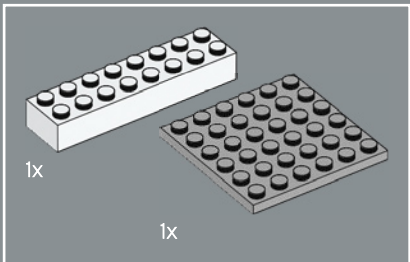
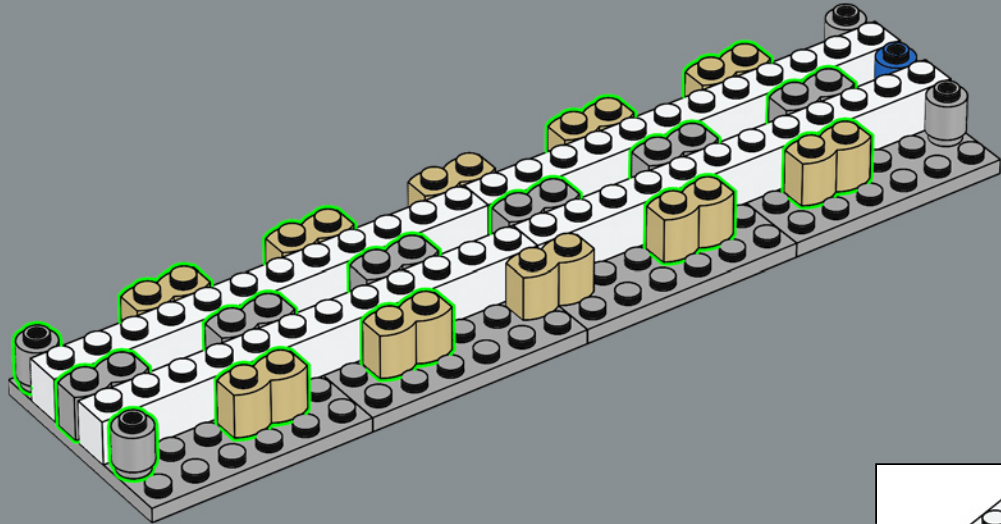

76

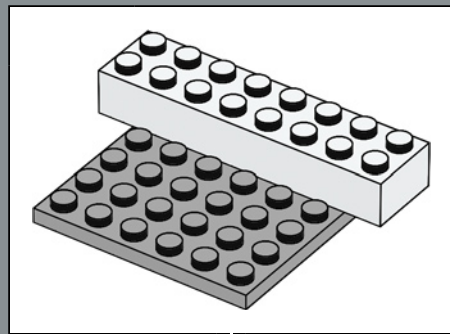
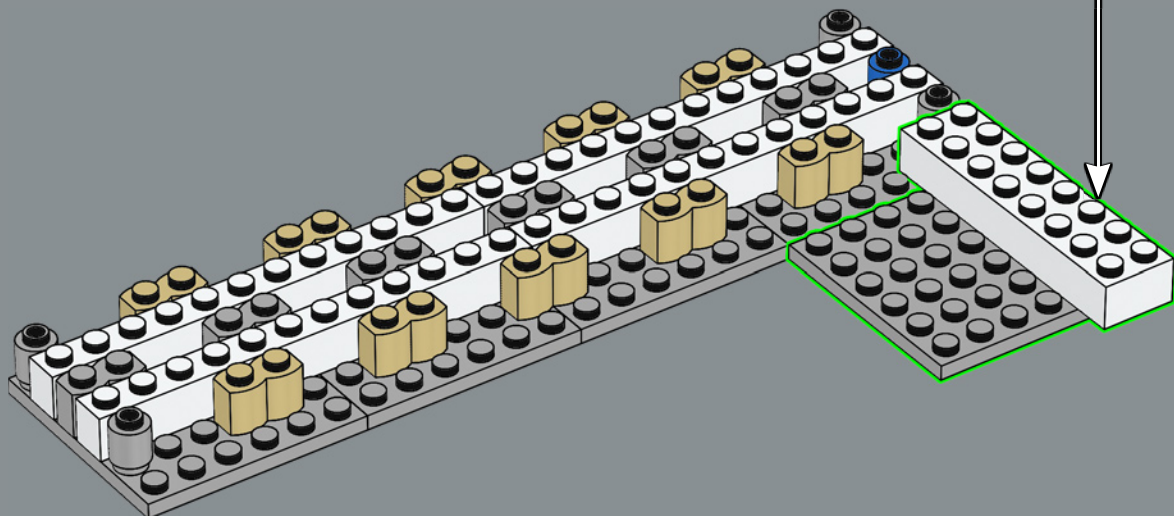

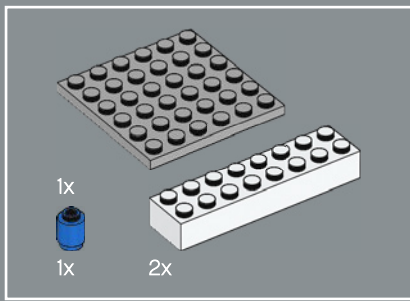

77

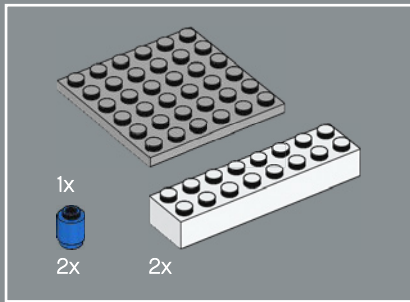
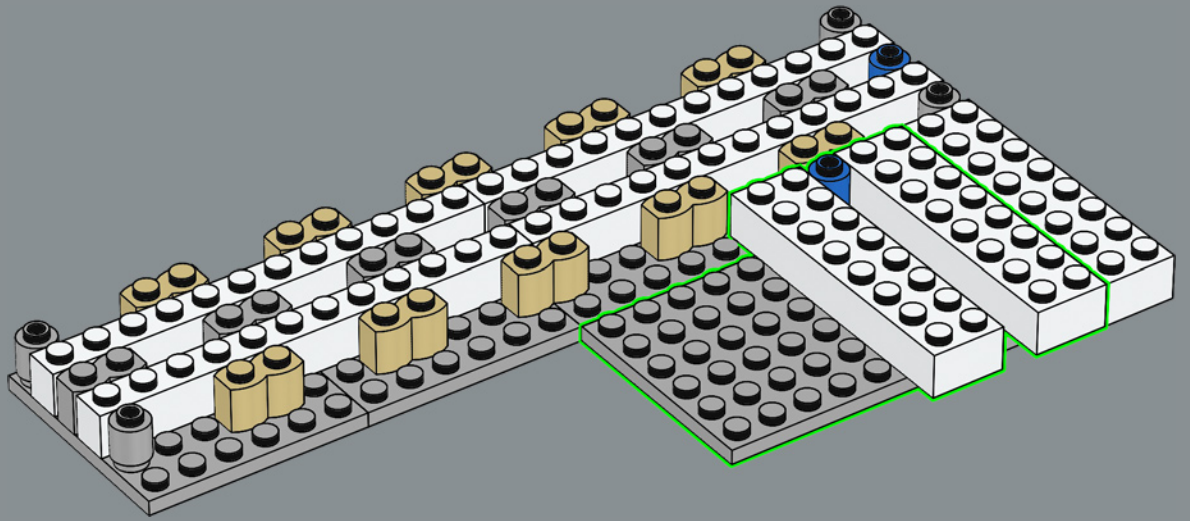

78

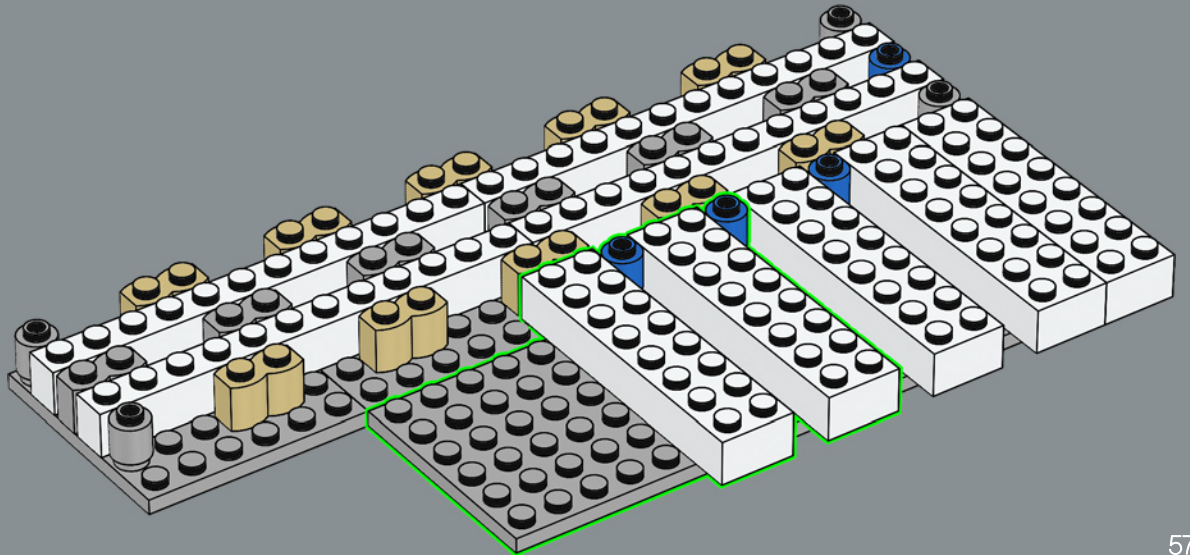

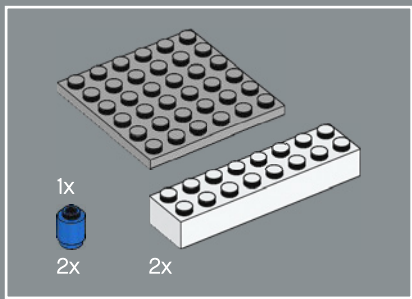

79

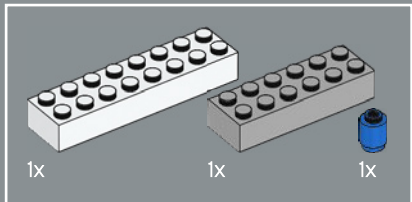
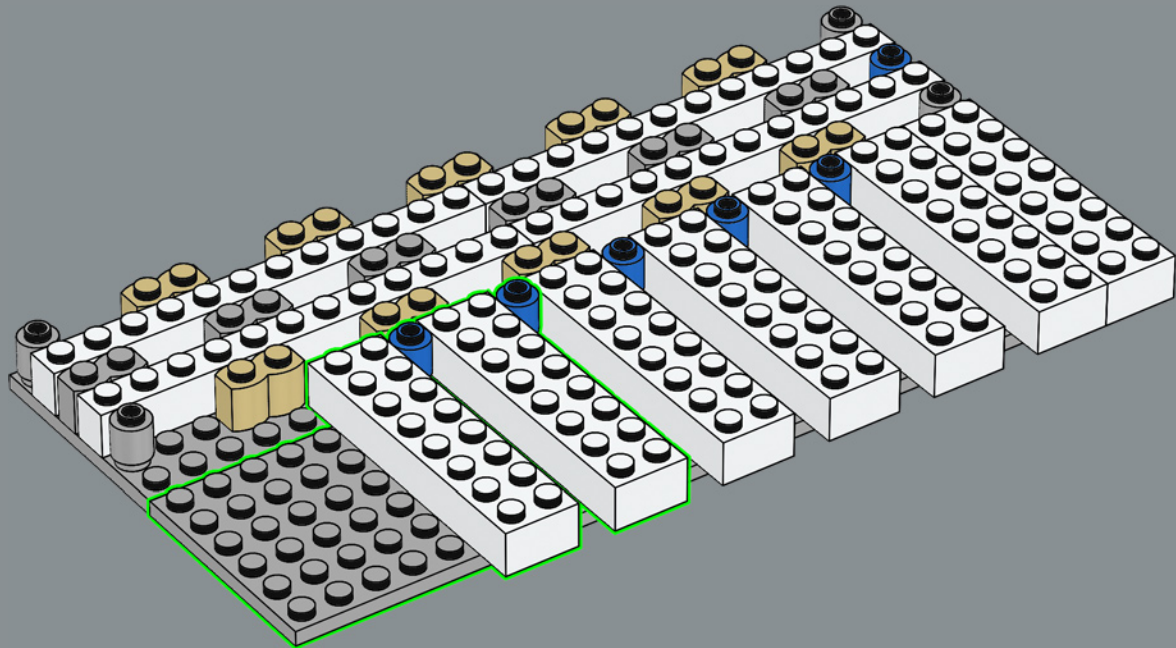

80

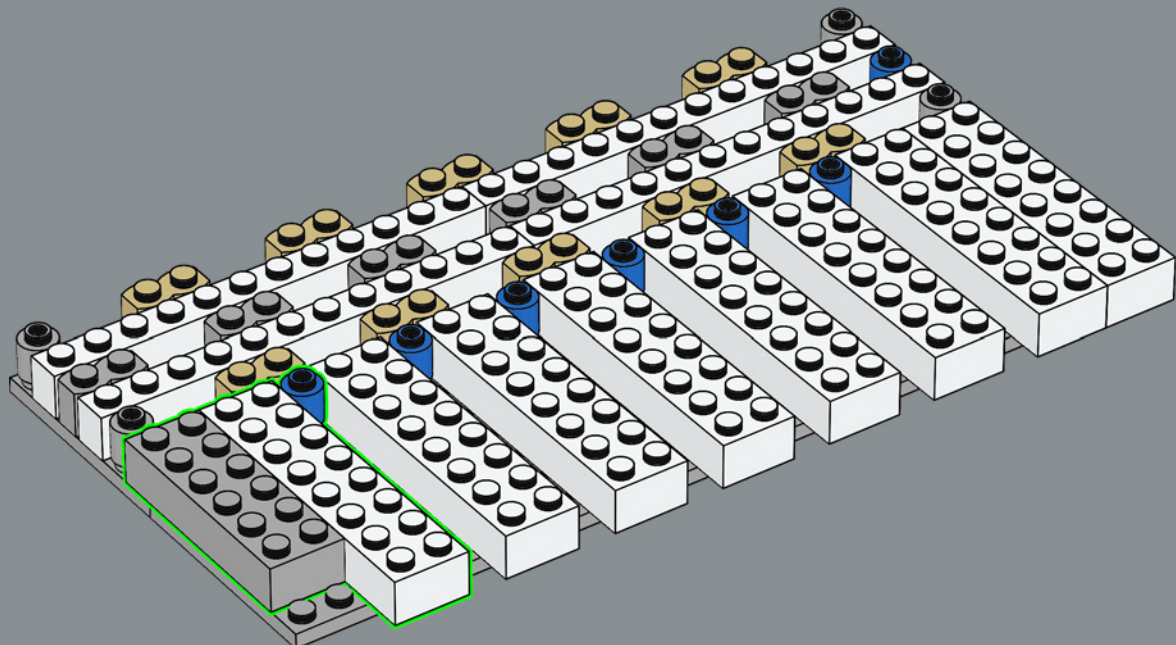

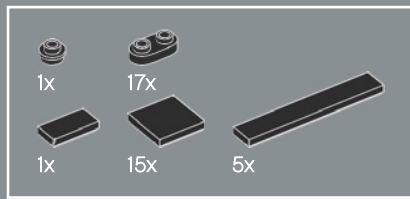

81

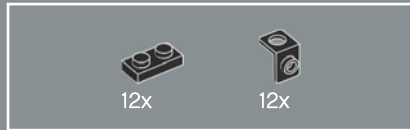
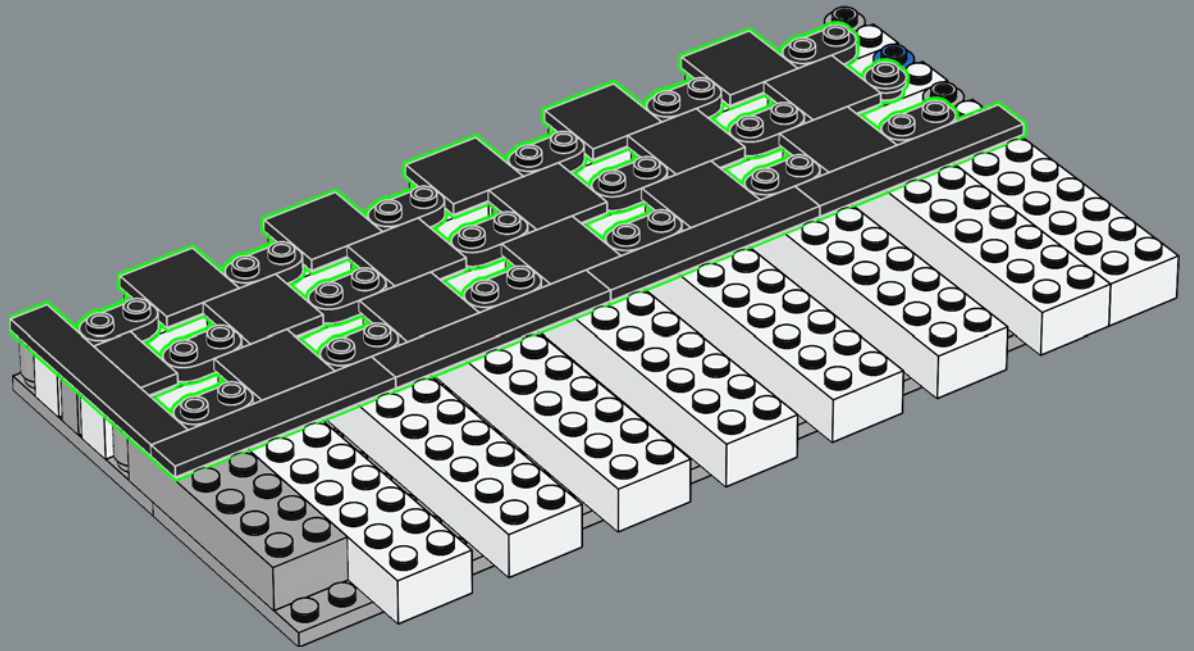

82

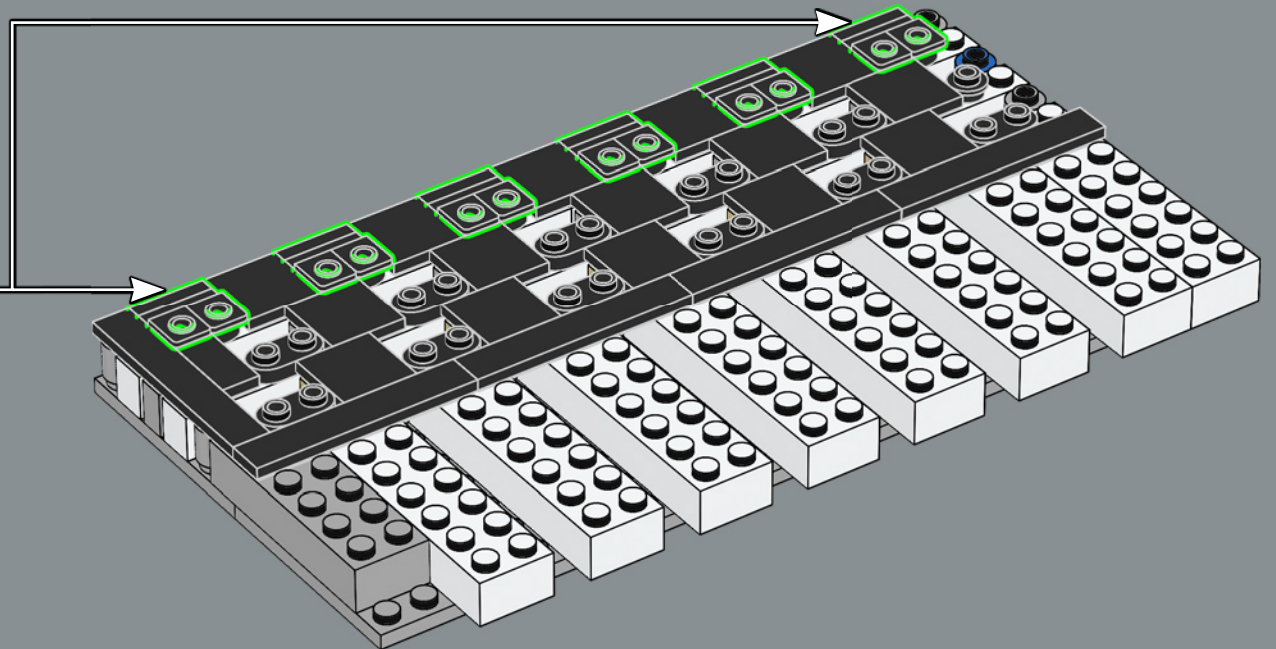
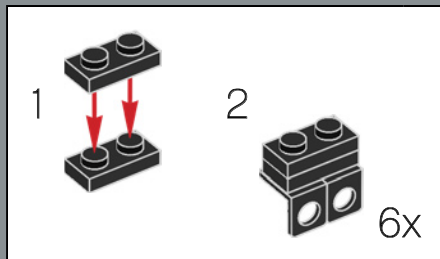



83

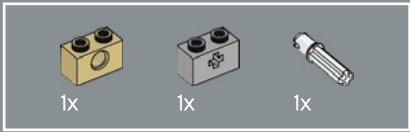
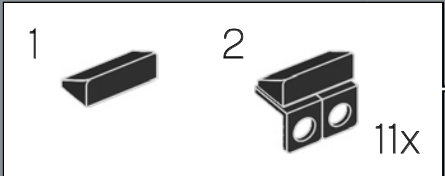
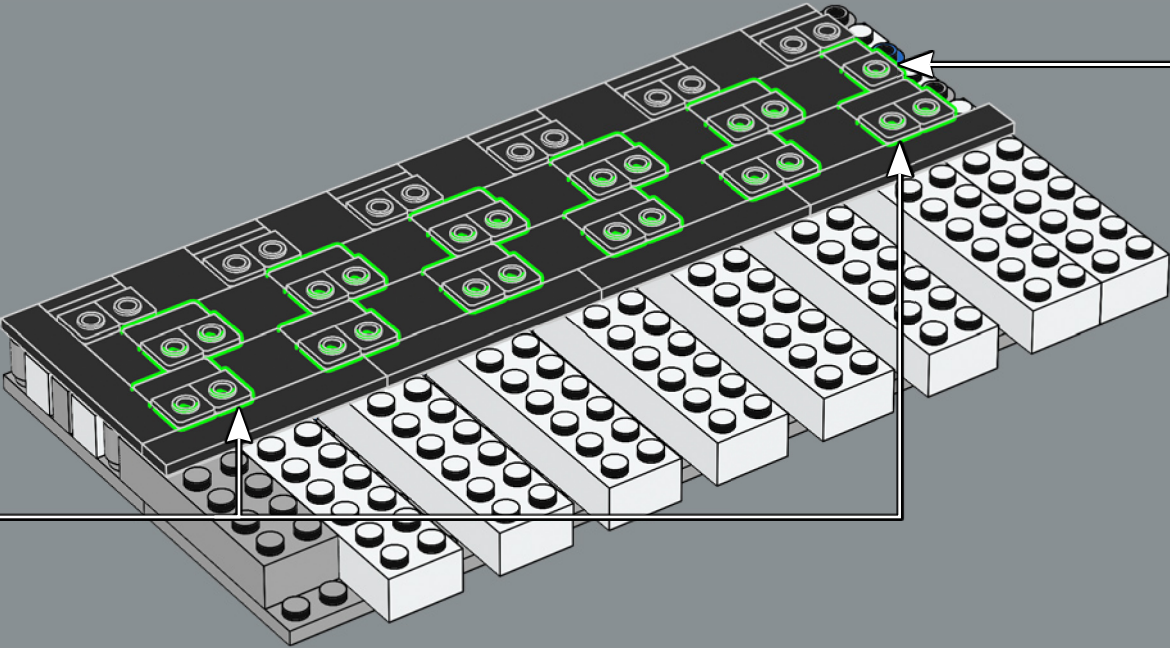
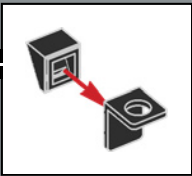

84

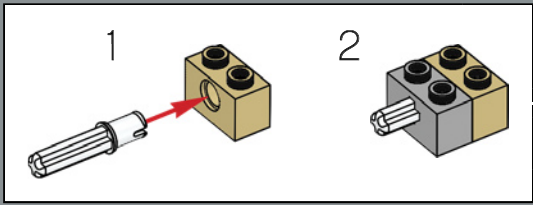
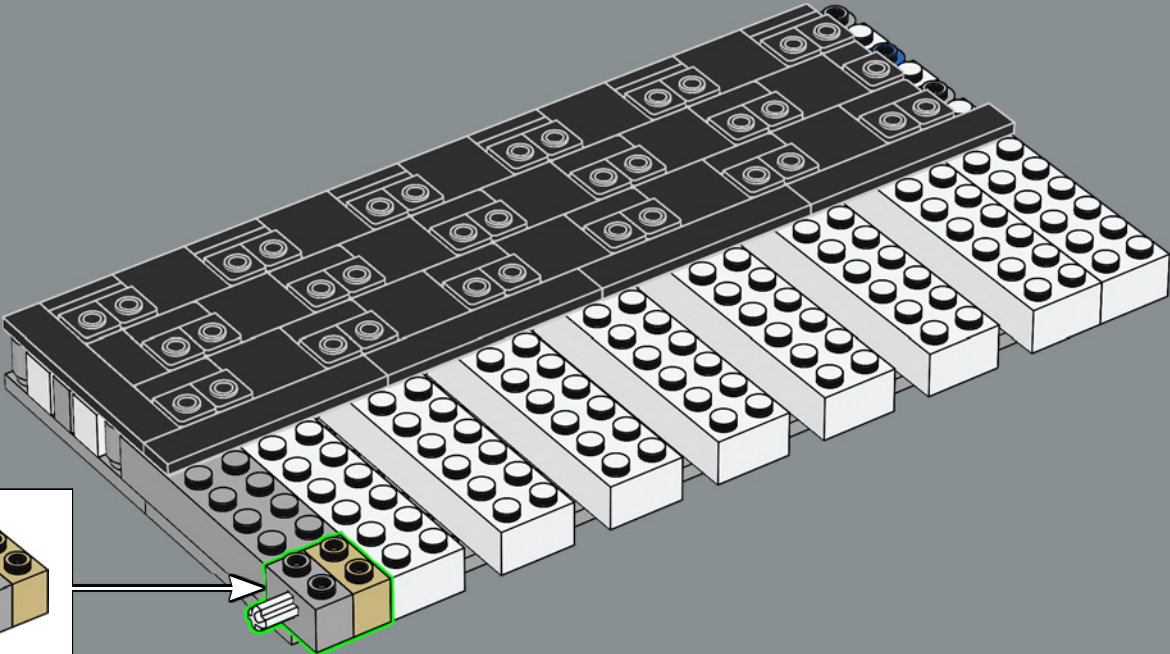

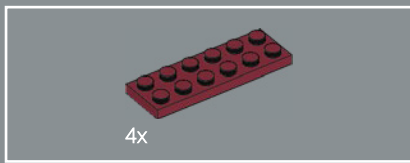

85

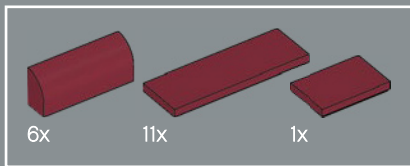
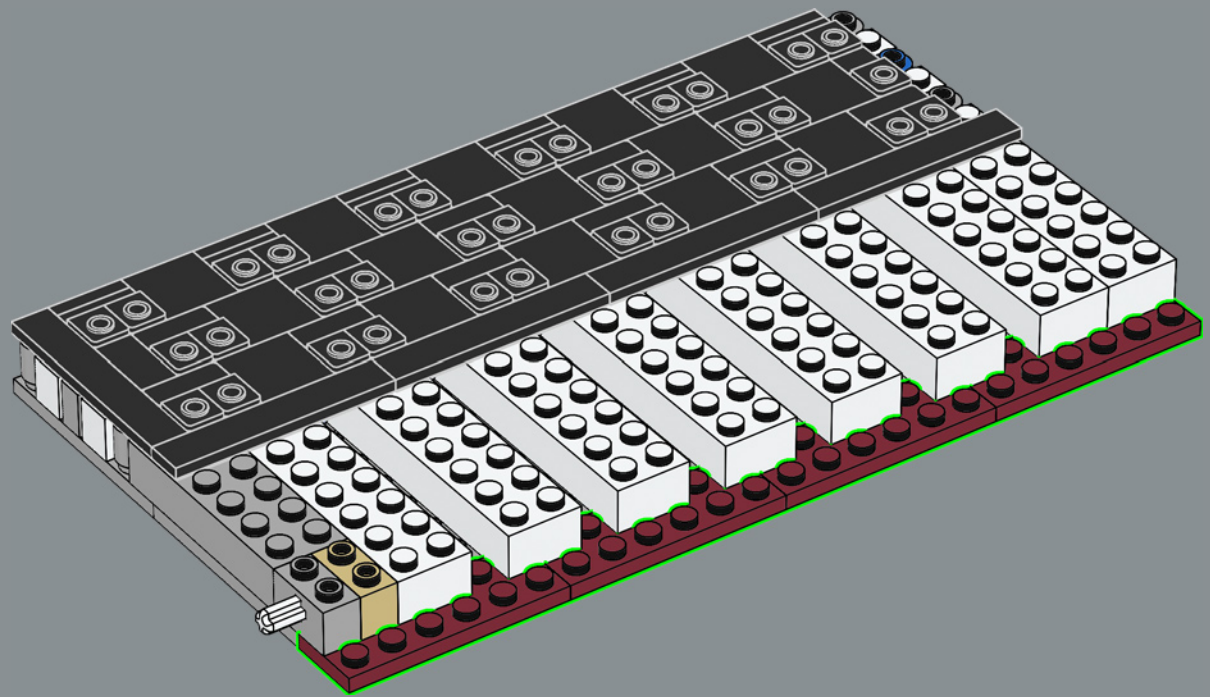

86

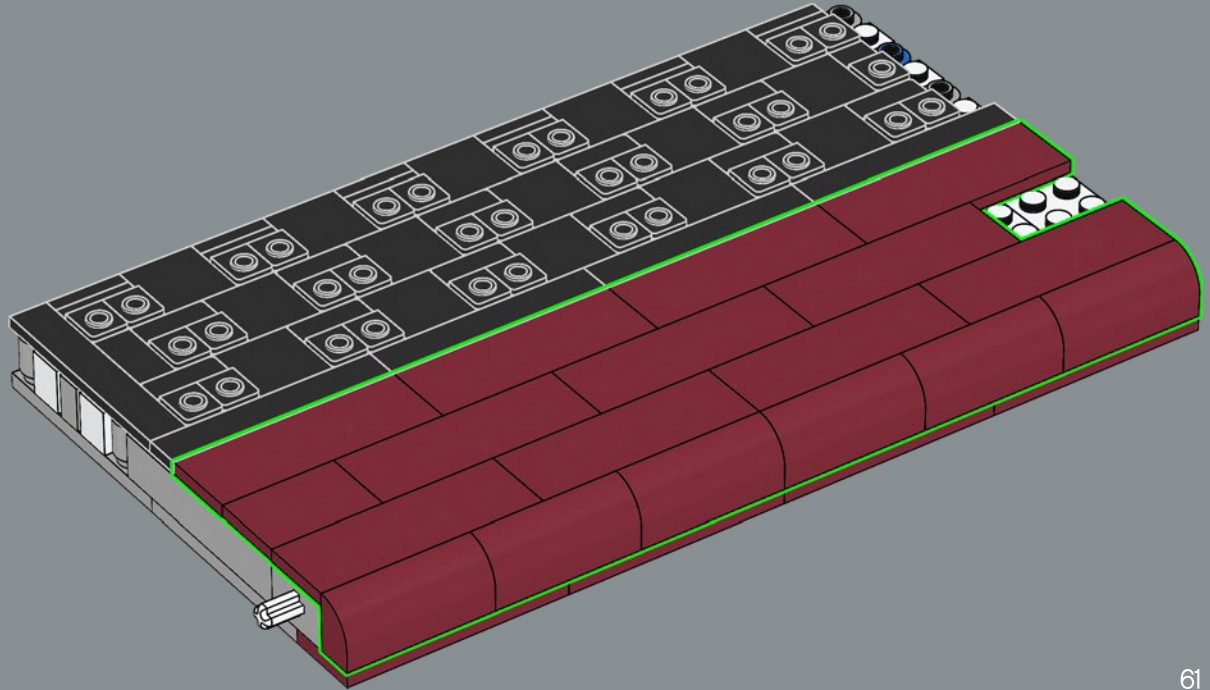

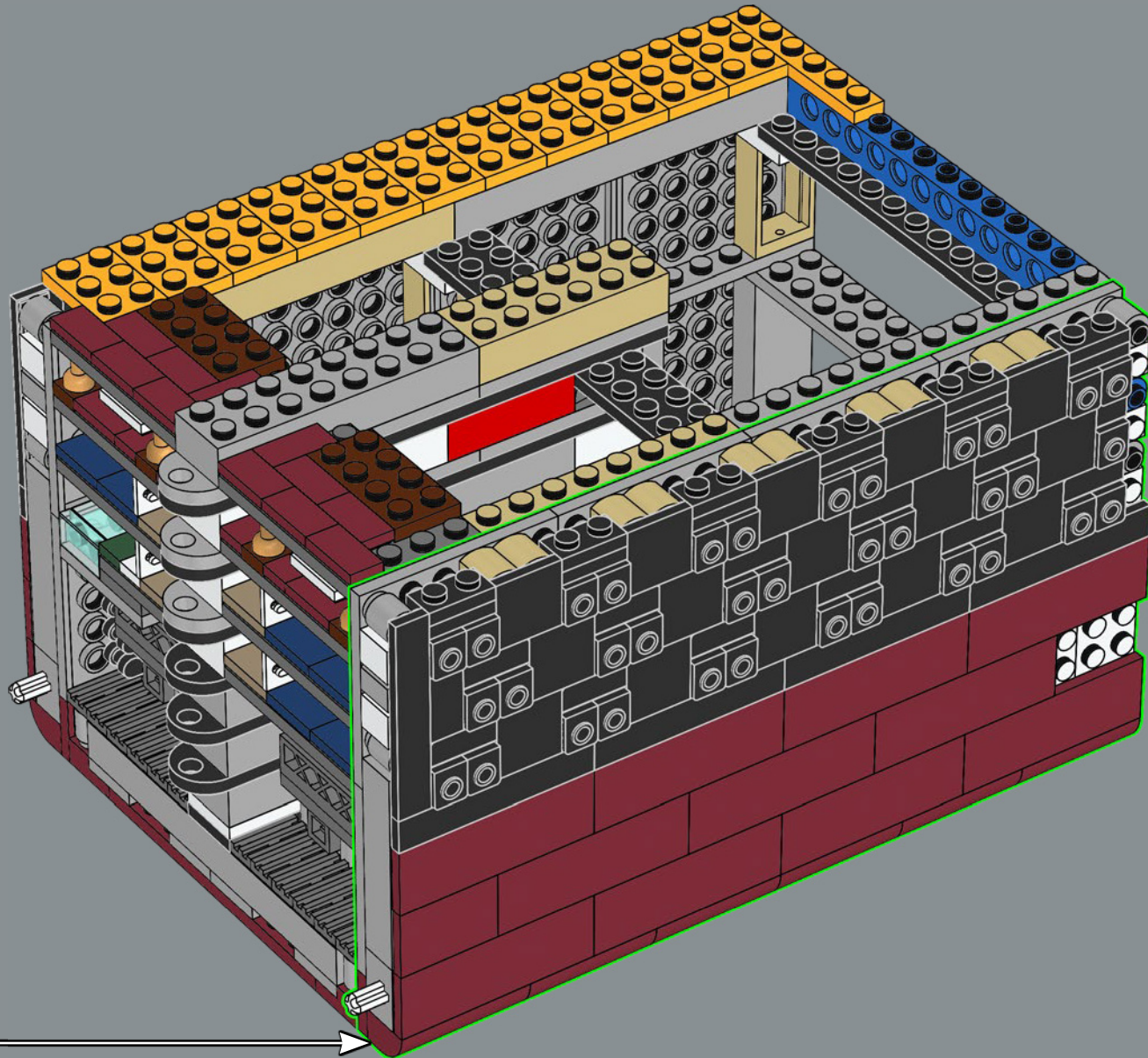

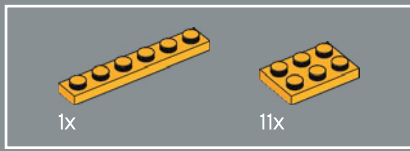

88

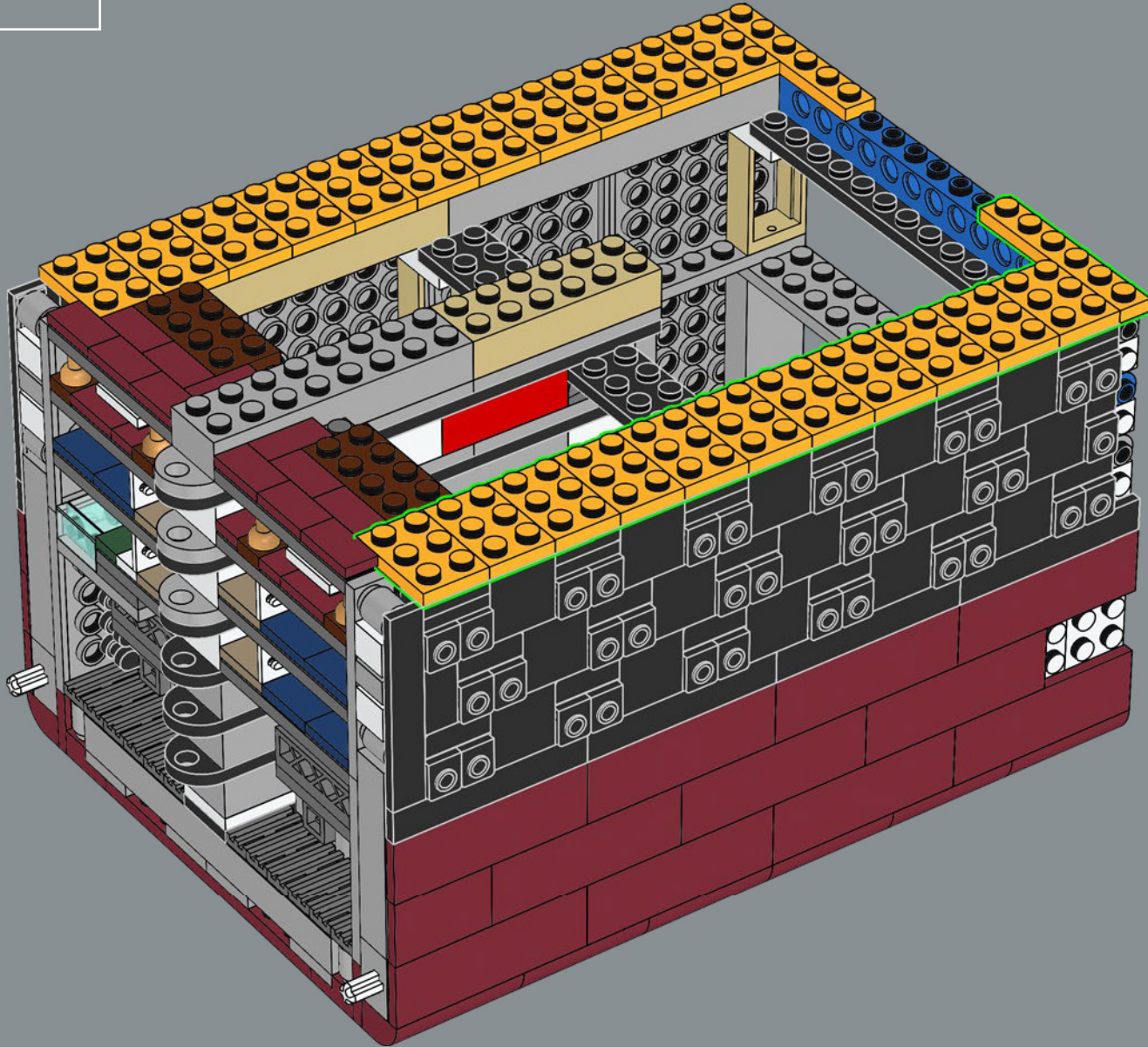

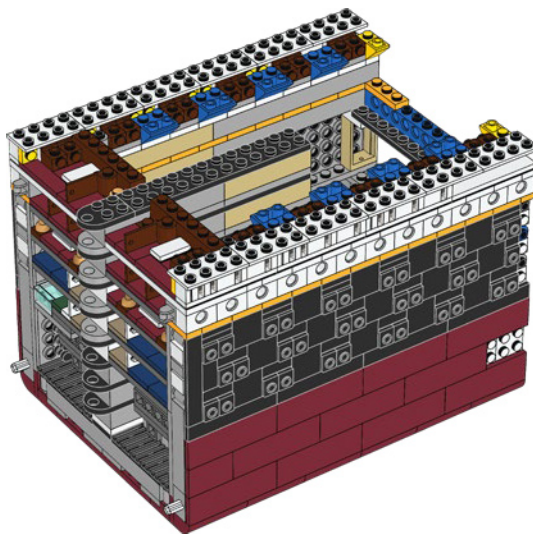
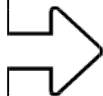

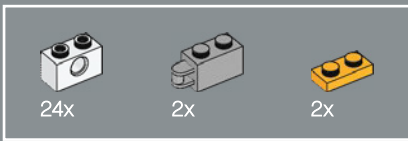

89

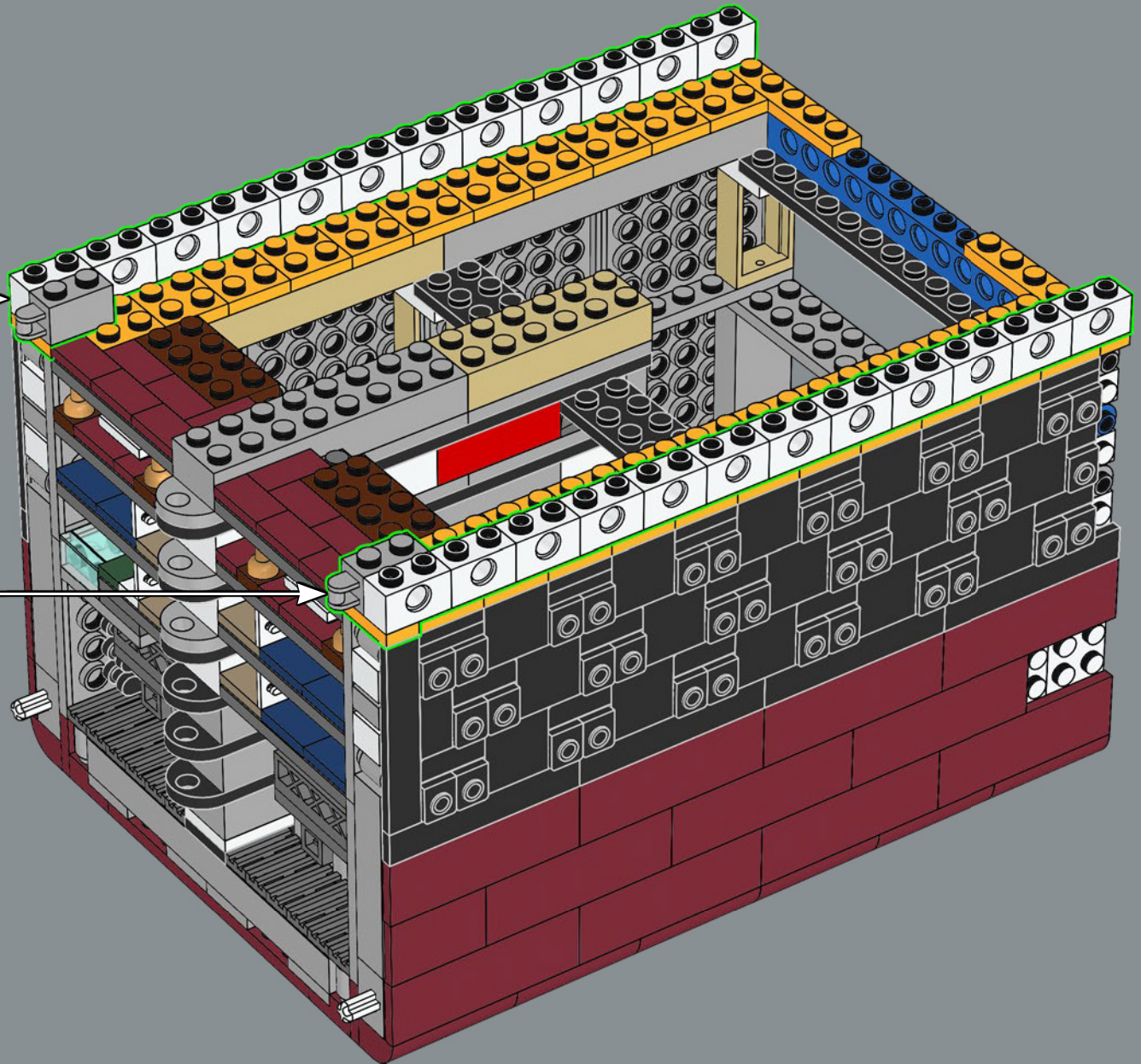
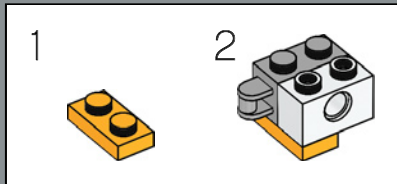
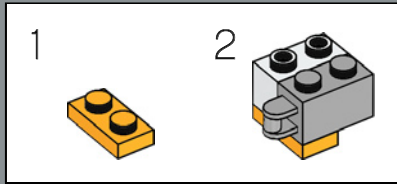

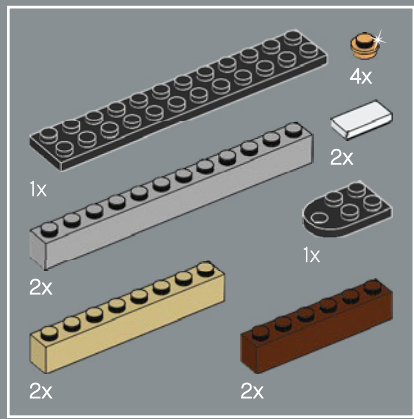

90

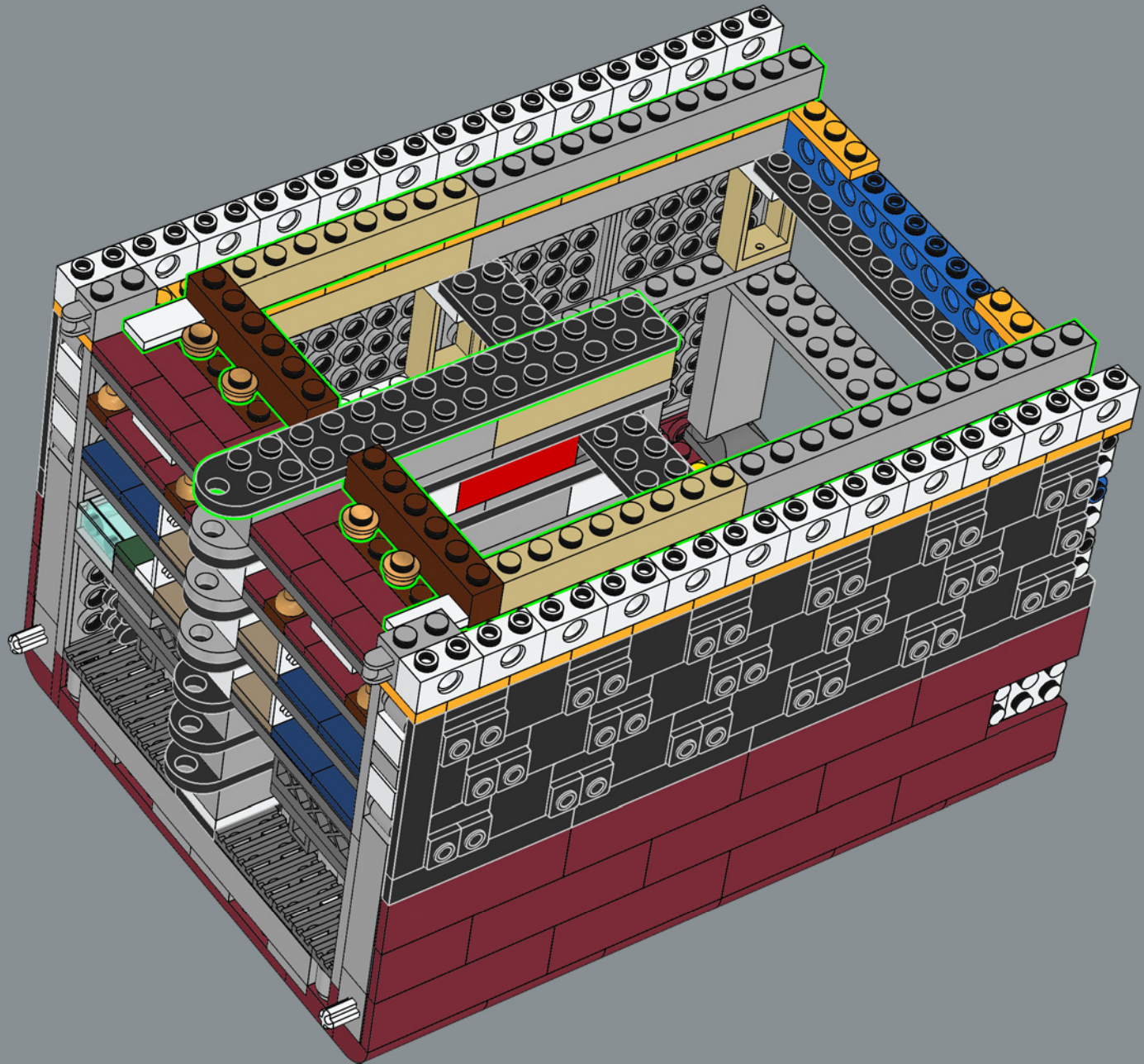

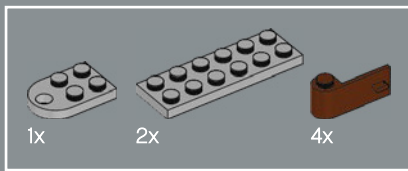

91

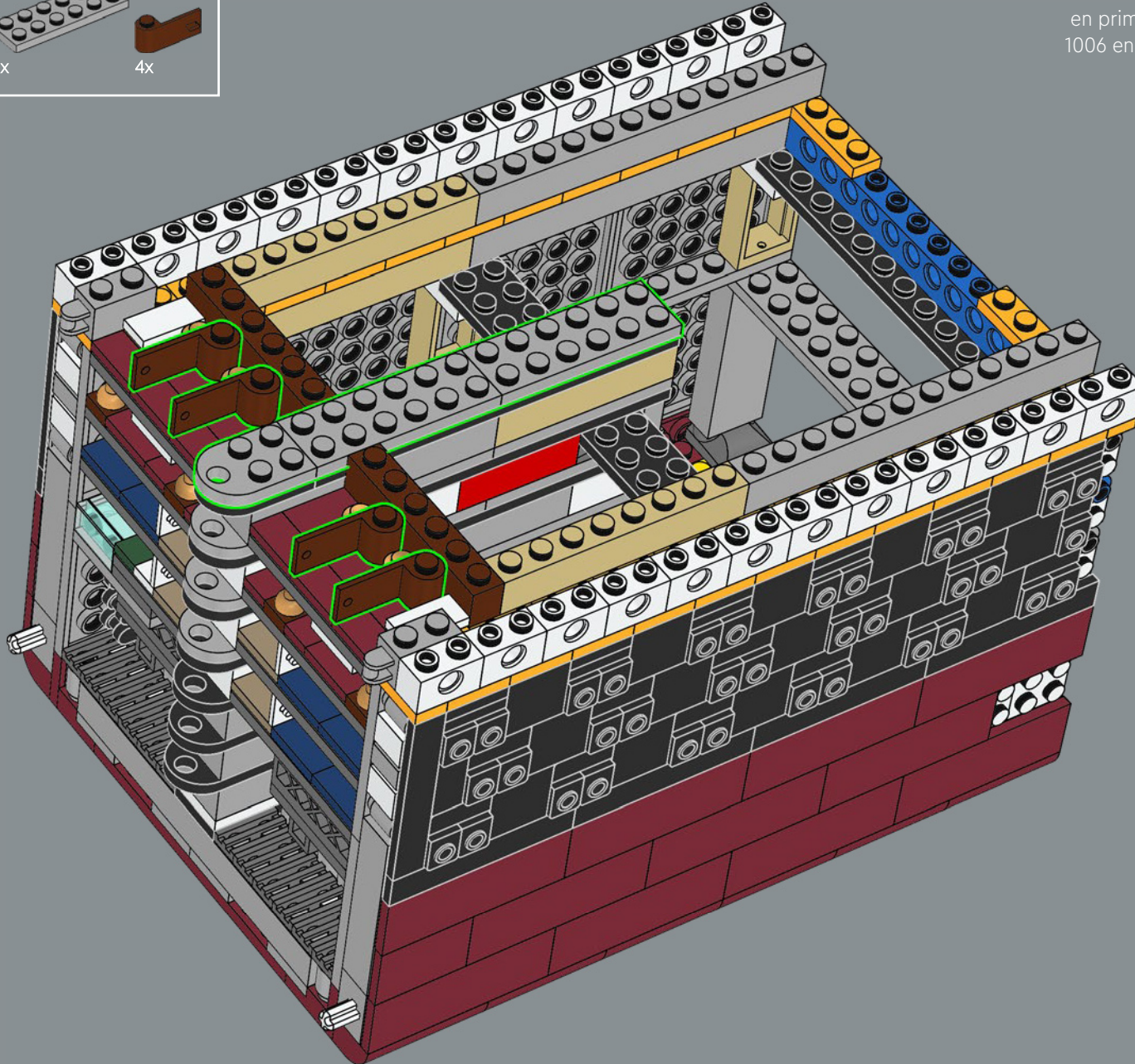

El *Titanic* podía alojar a 833 pasajeros en primera clase, 614 en segunda clase y 1006 en tercera clase, con una capacidad total de 2453 pasajeros.

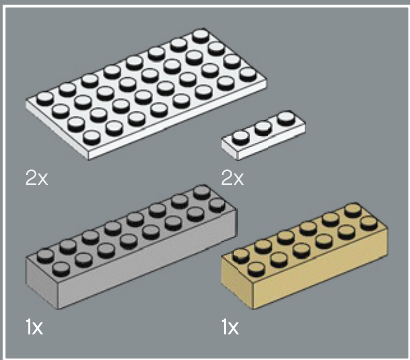

92

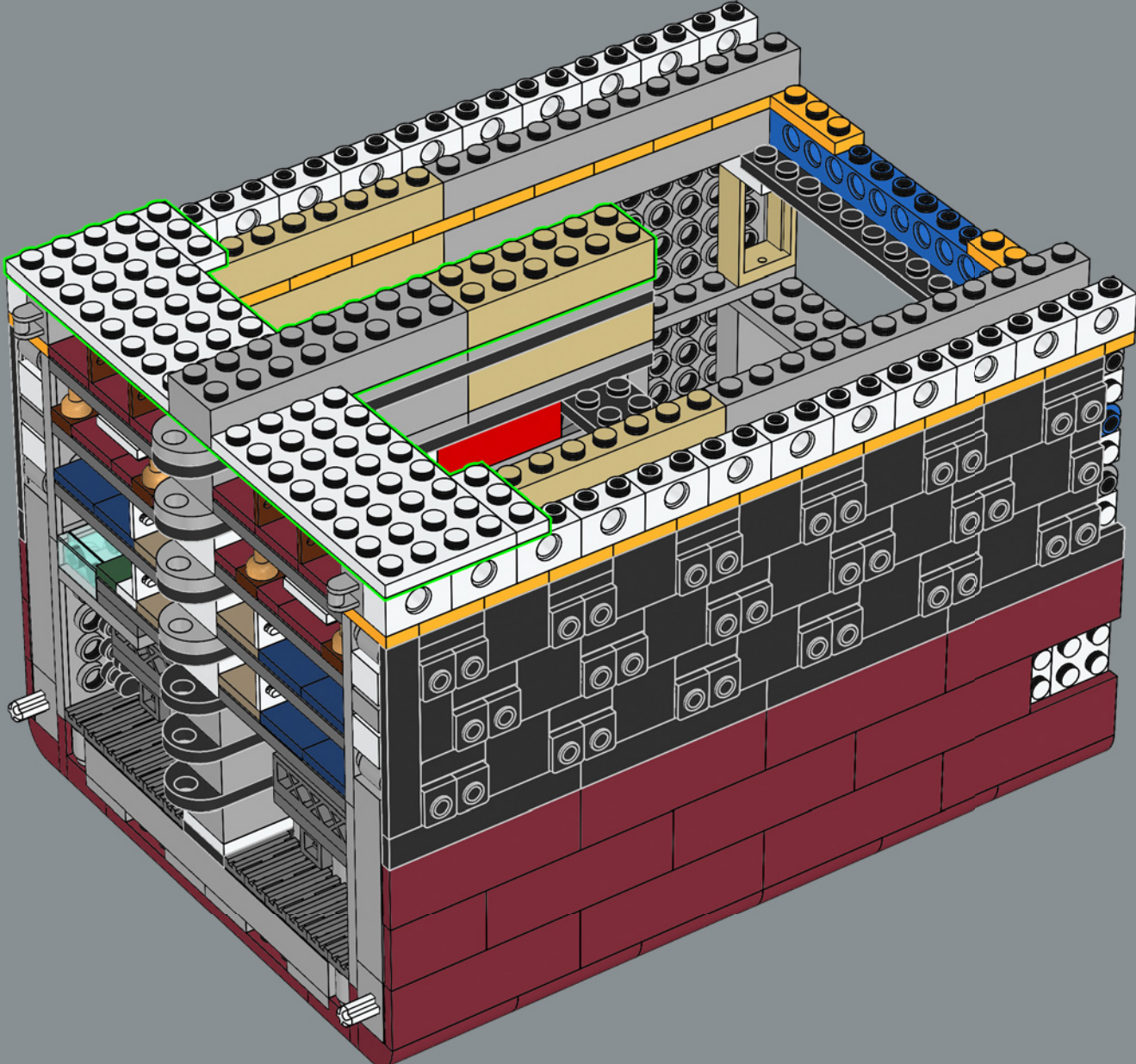

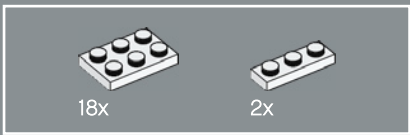

93

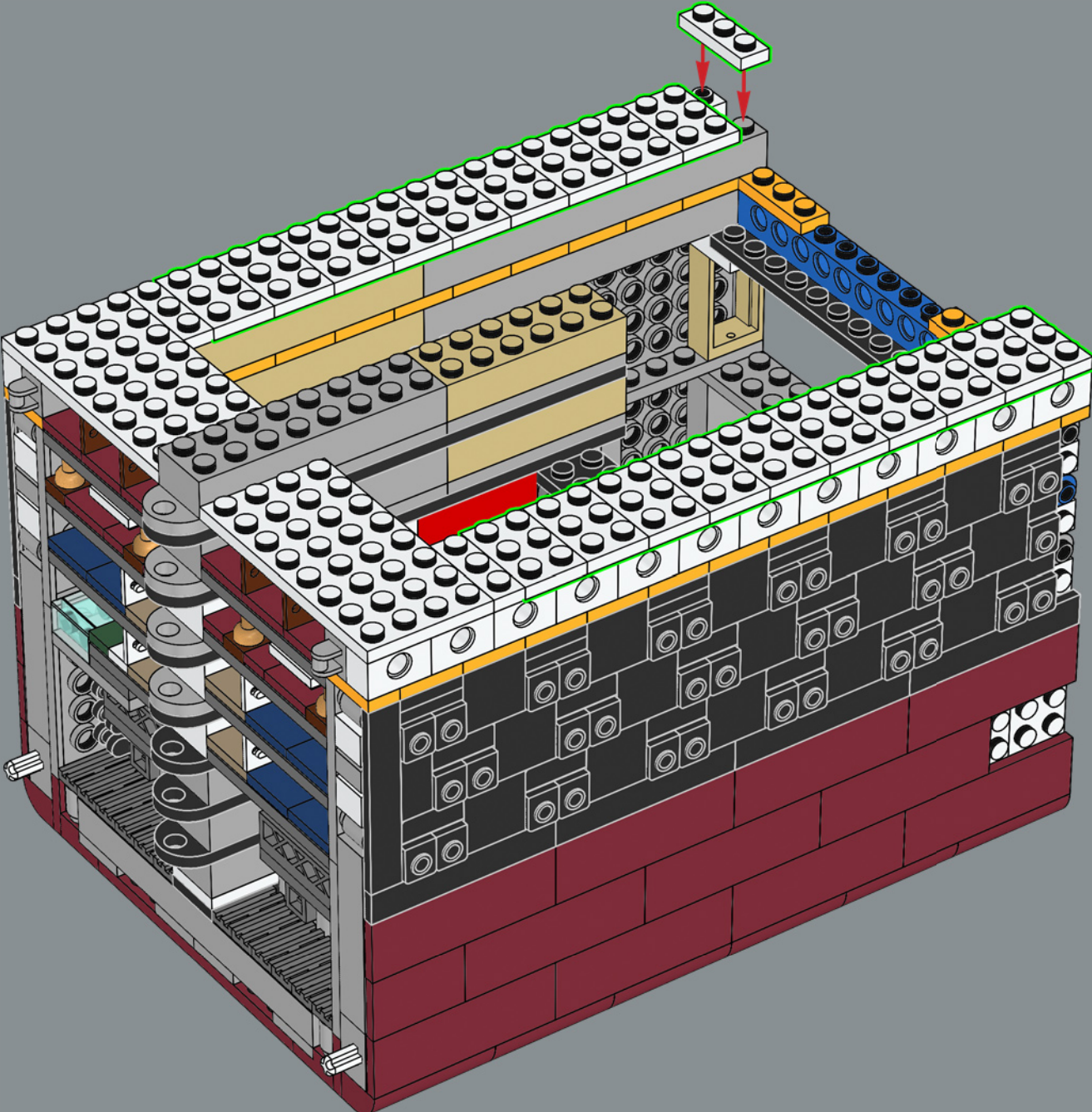

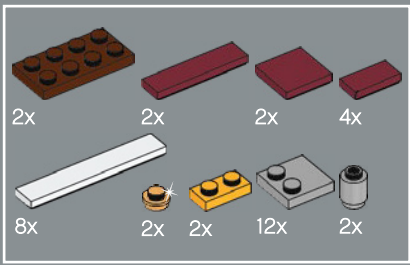

94

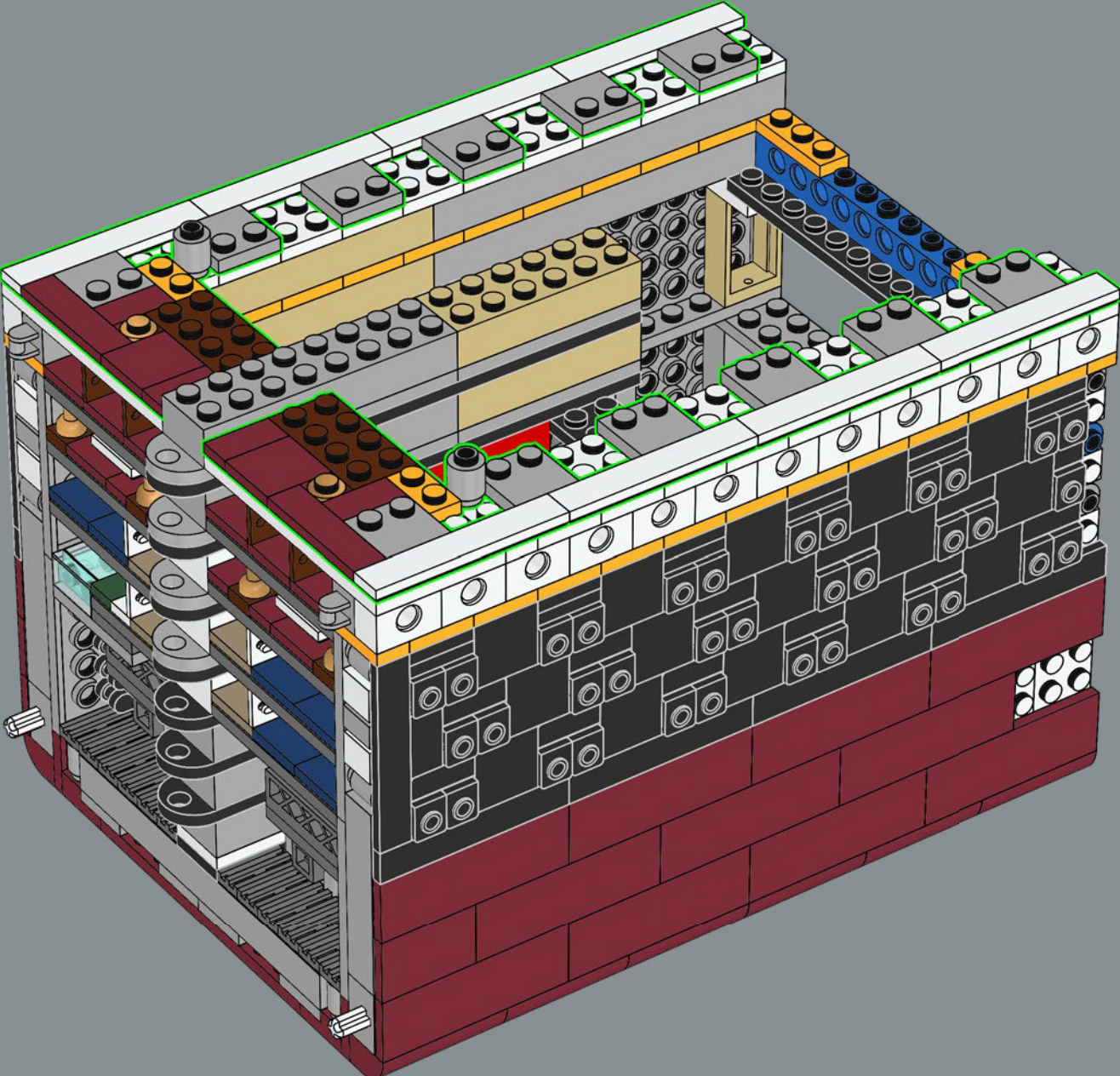

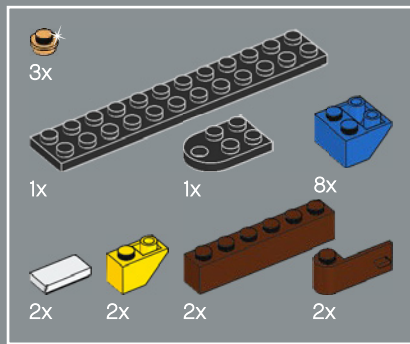

95

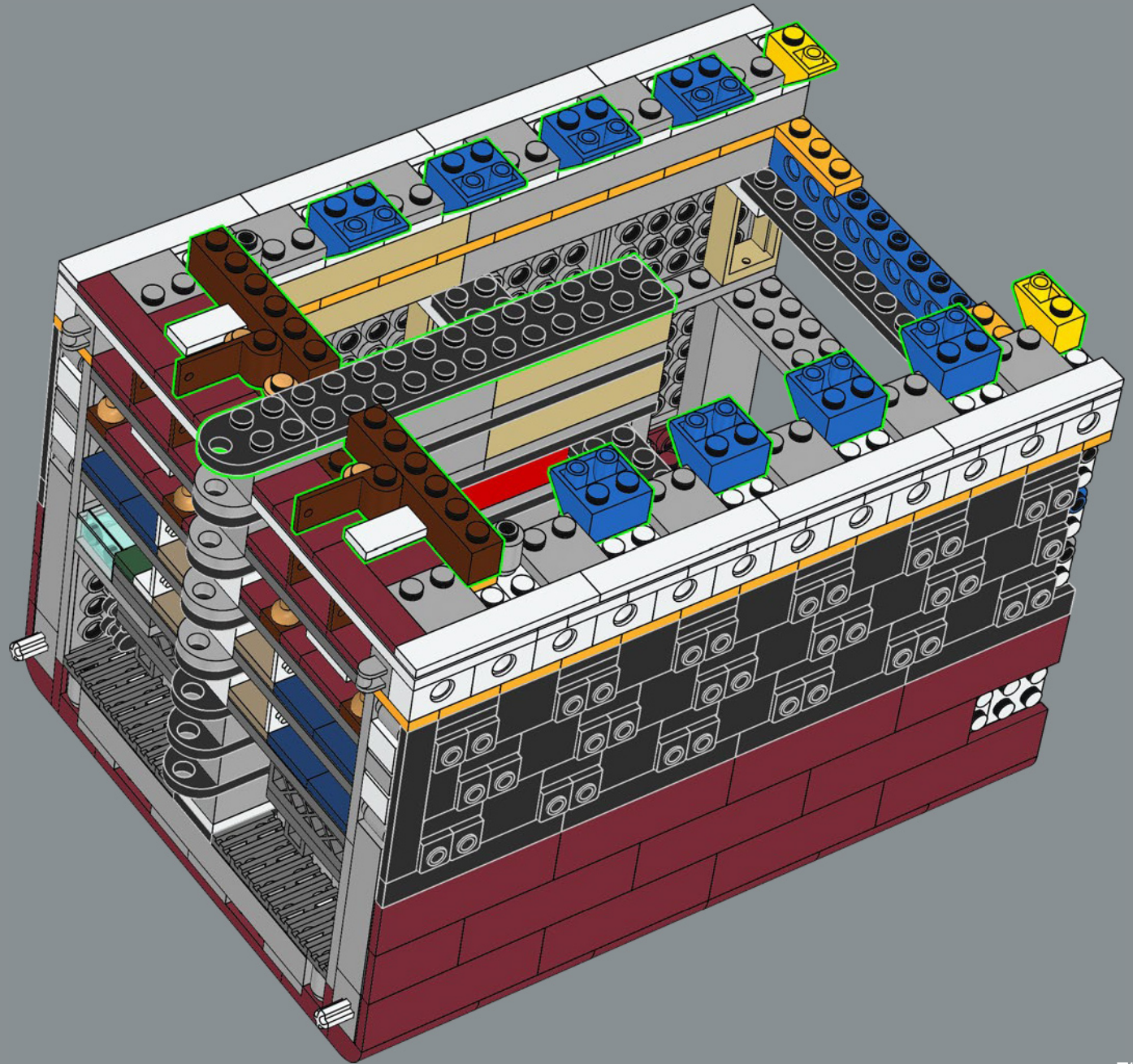

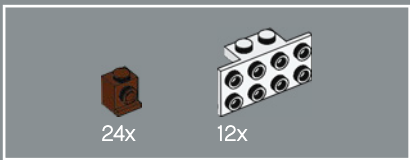

96

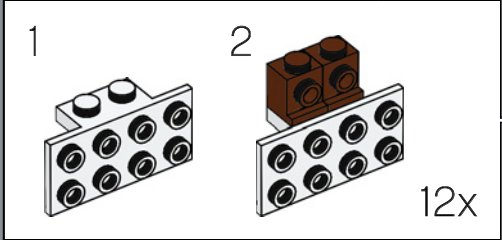
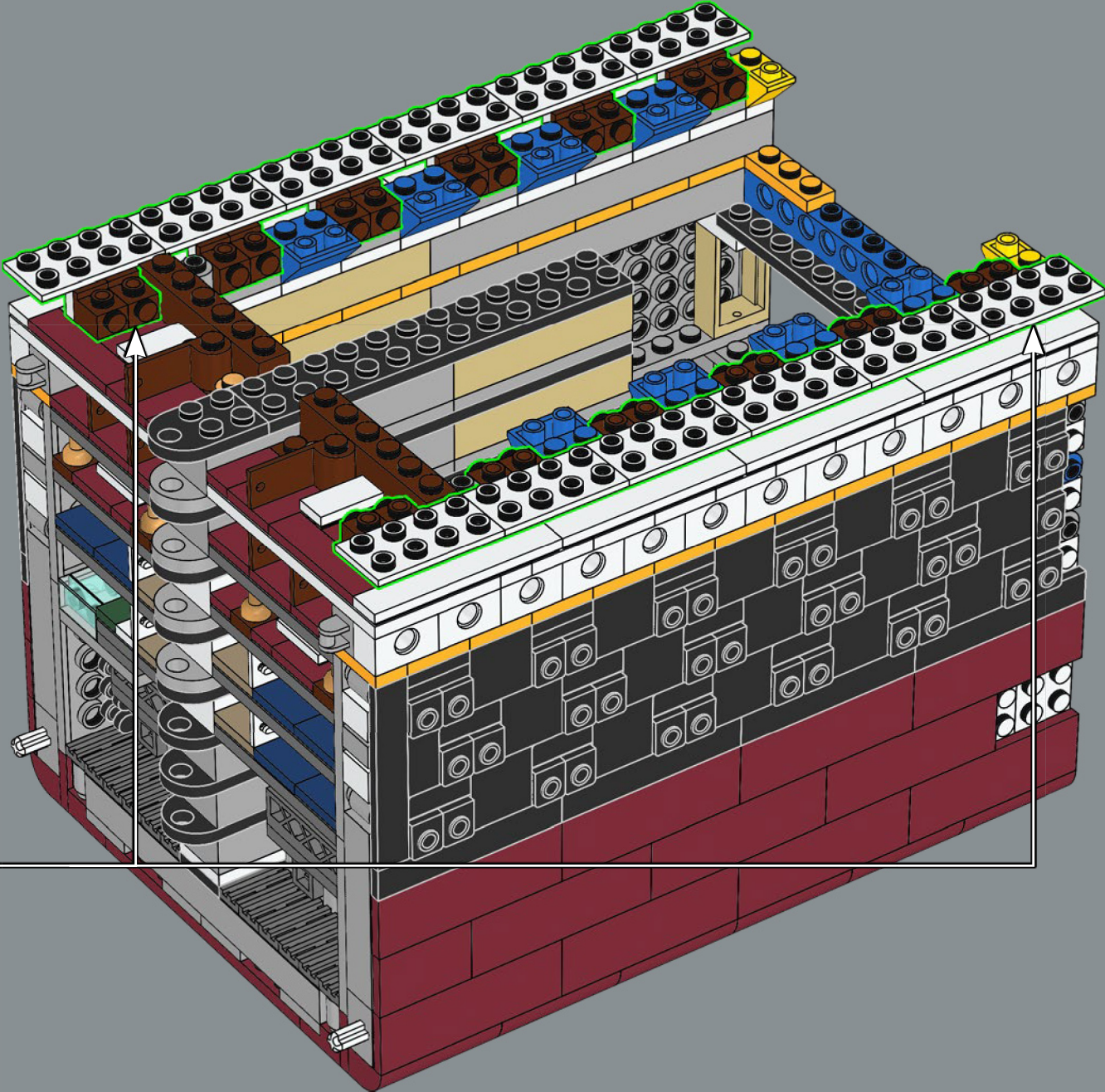

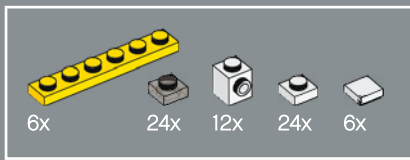

97

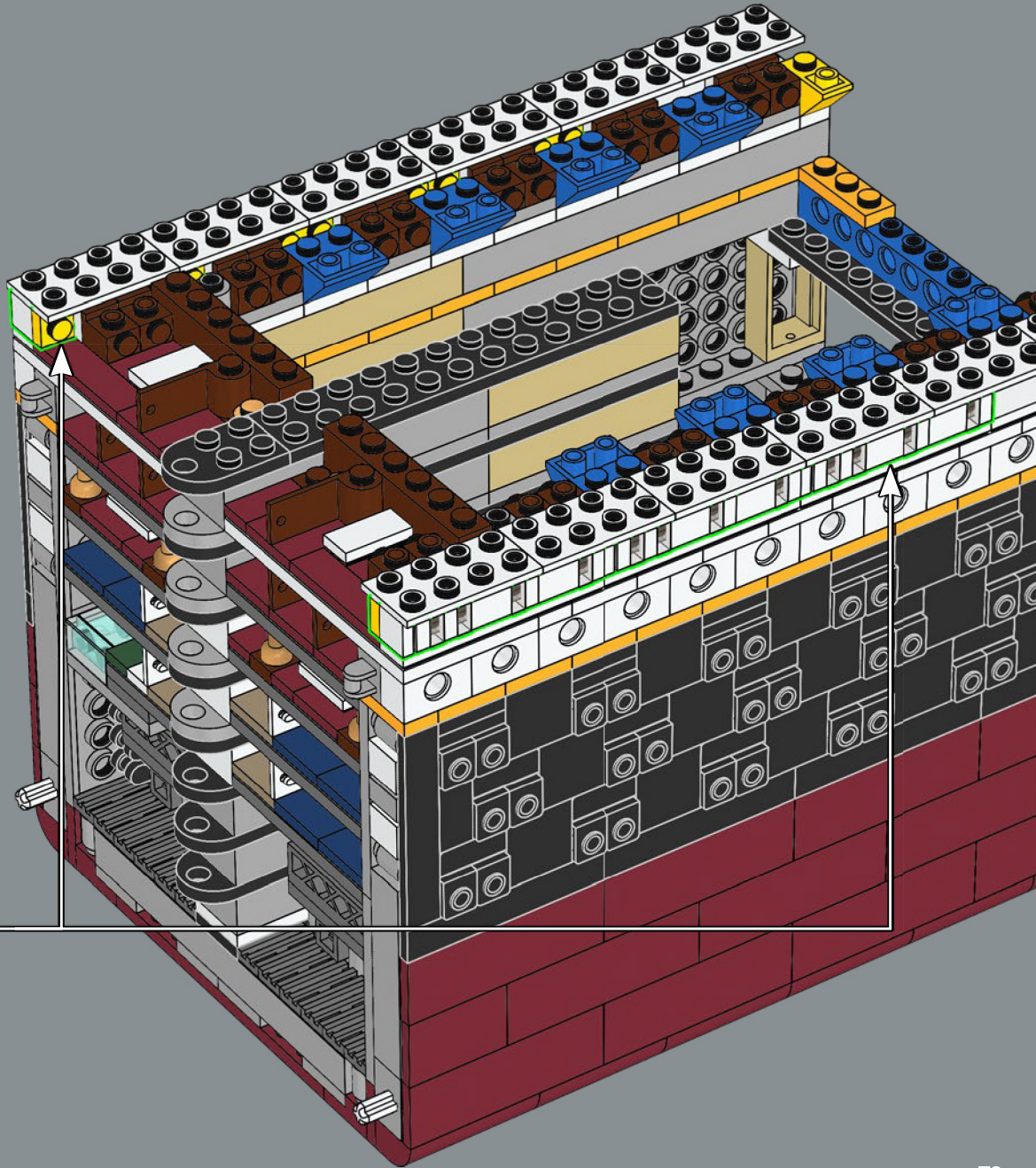
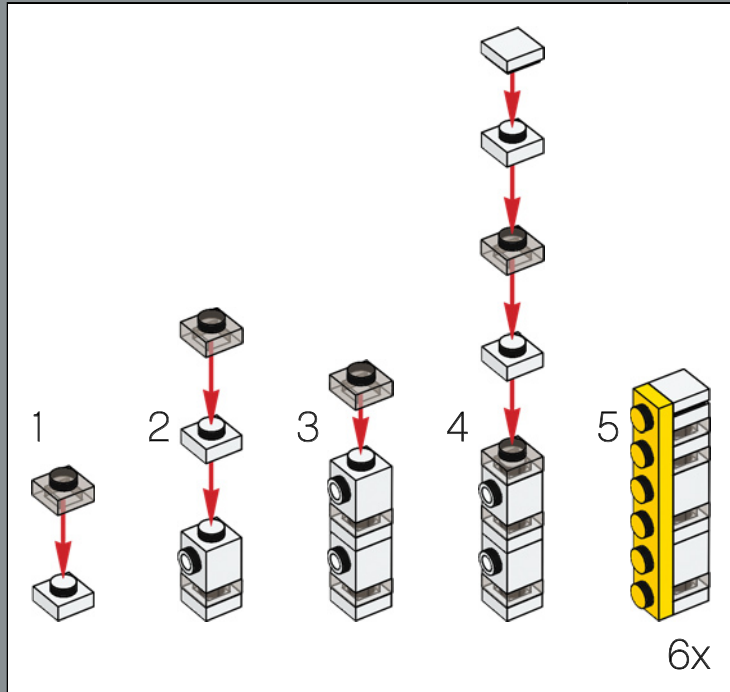

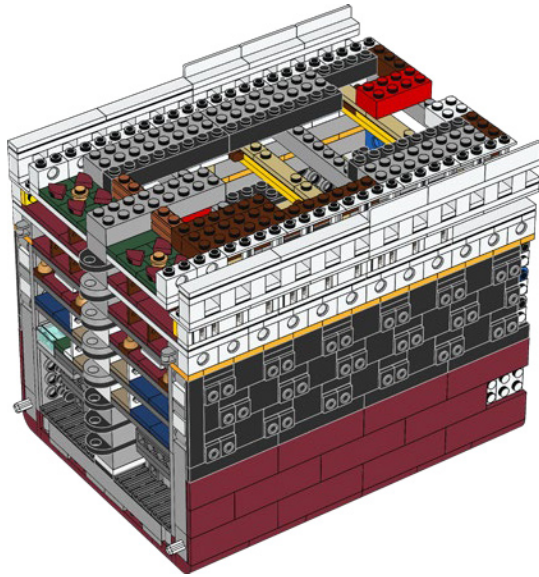
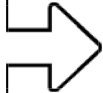

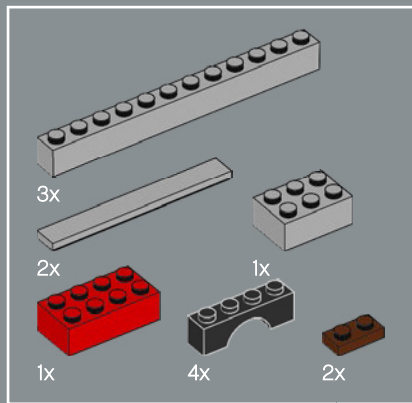

98

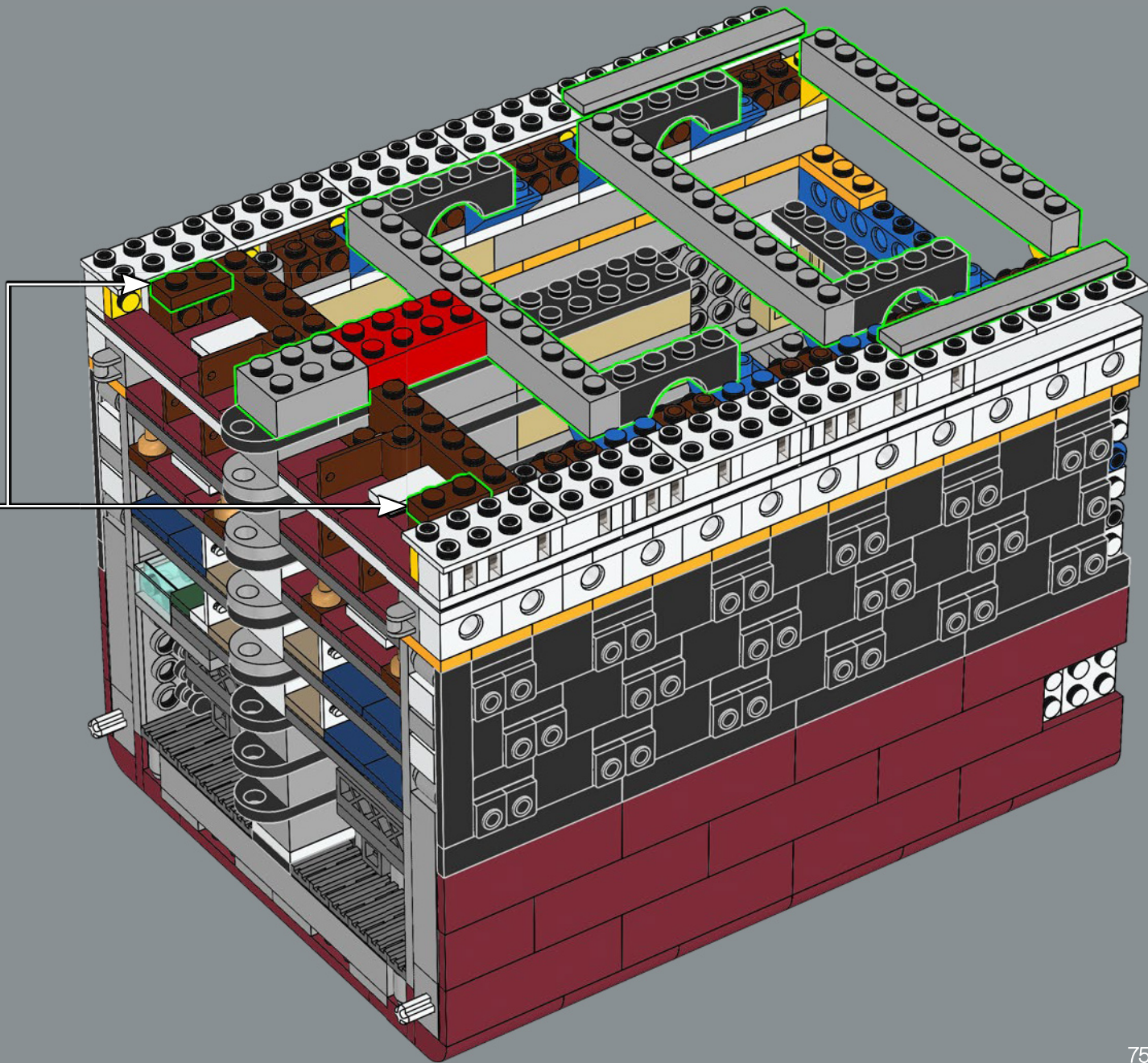
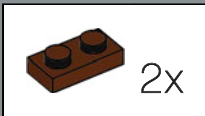

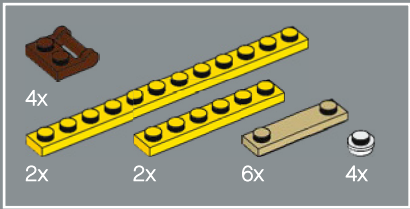

99

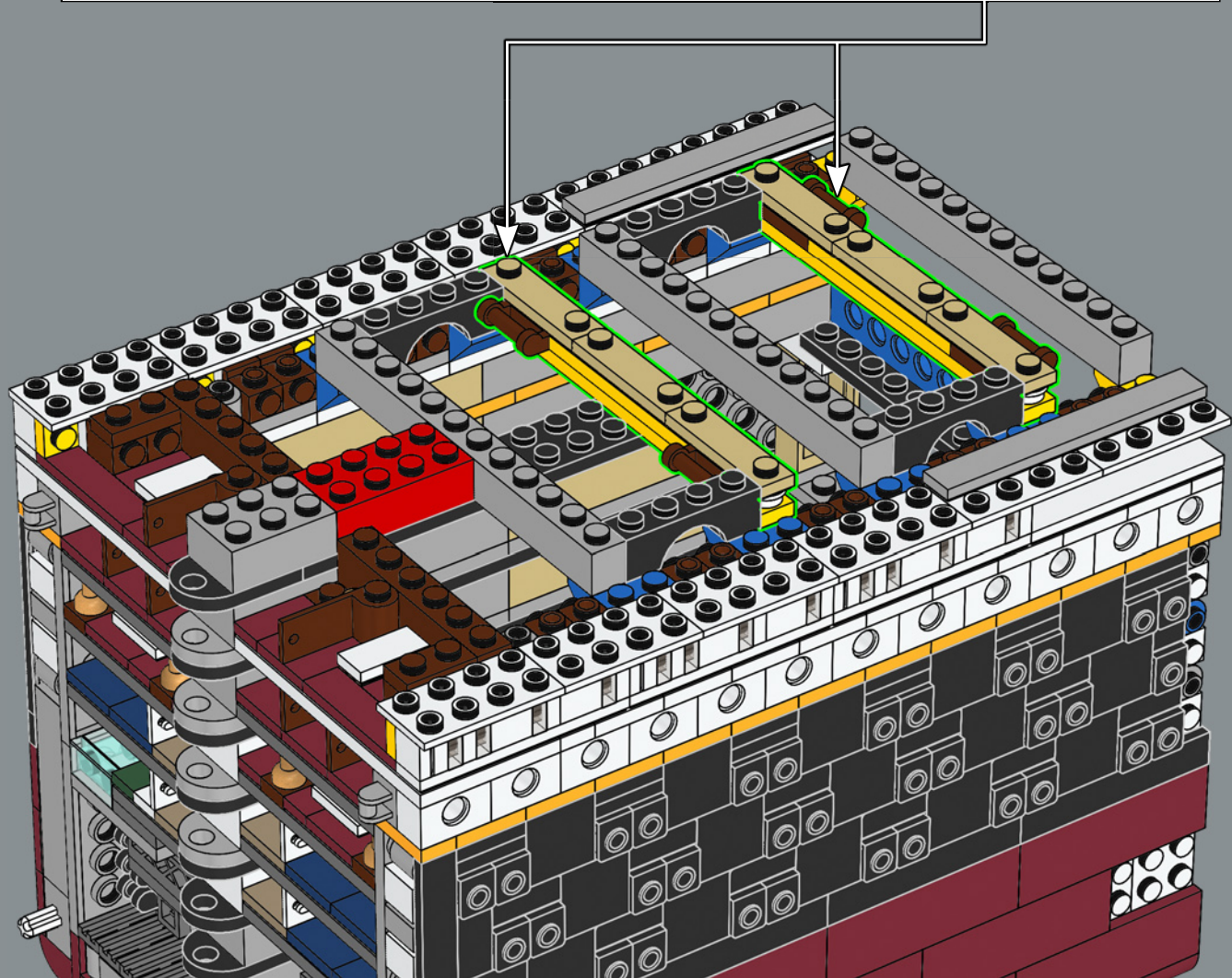
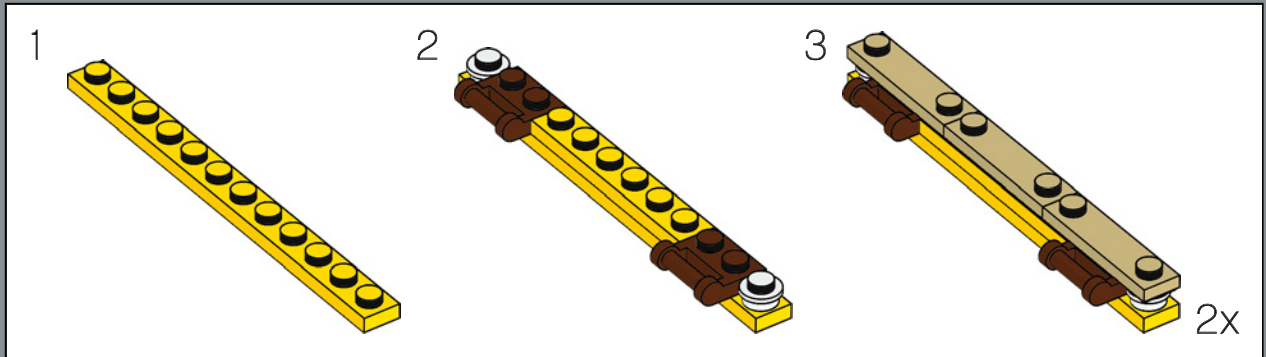

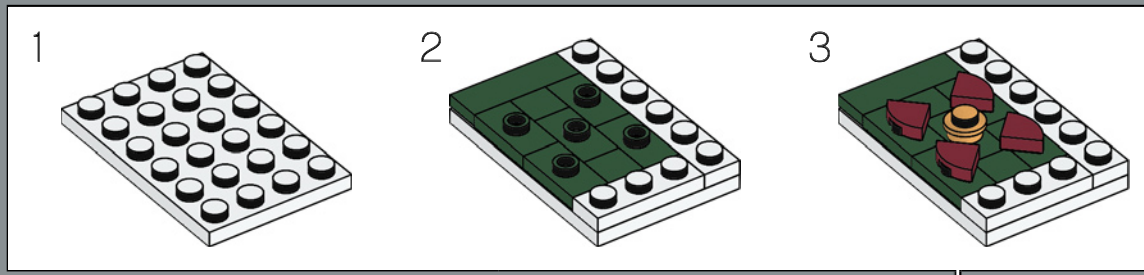
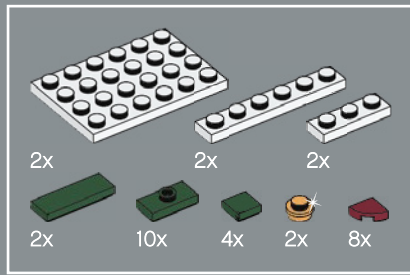

100

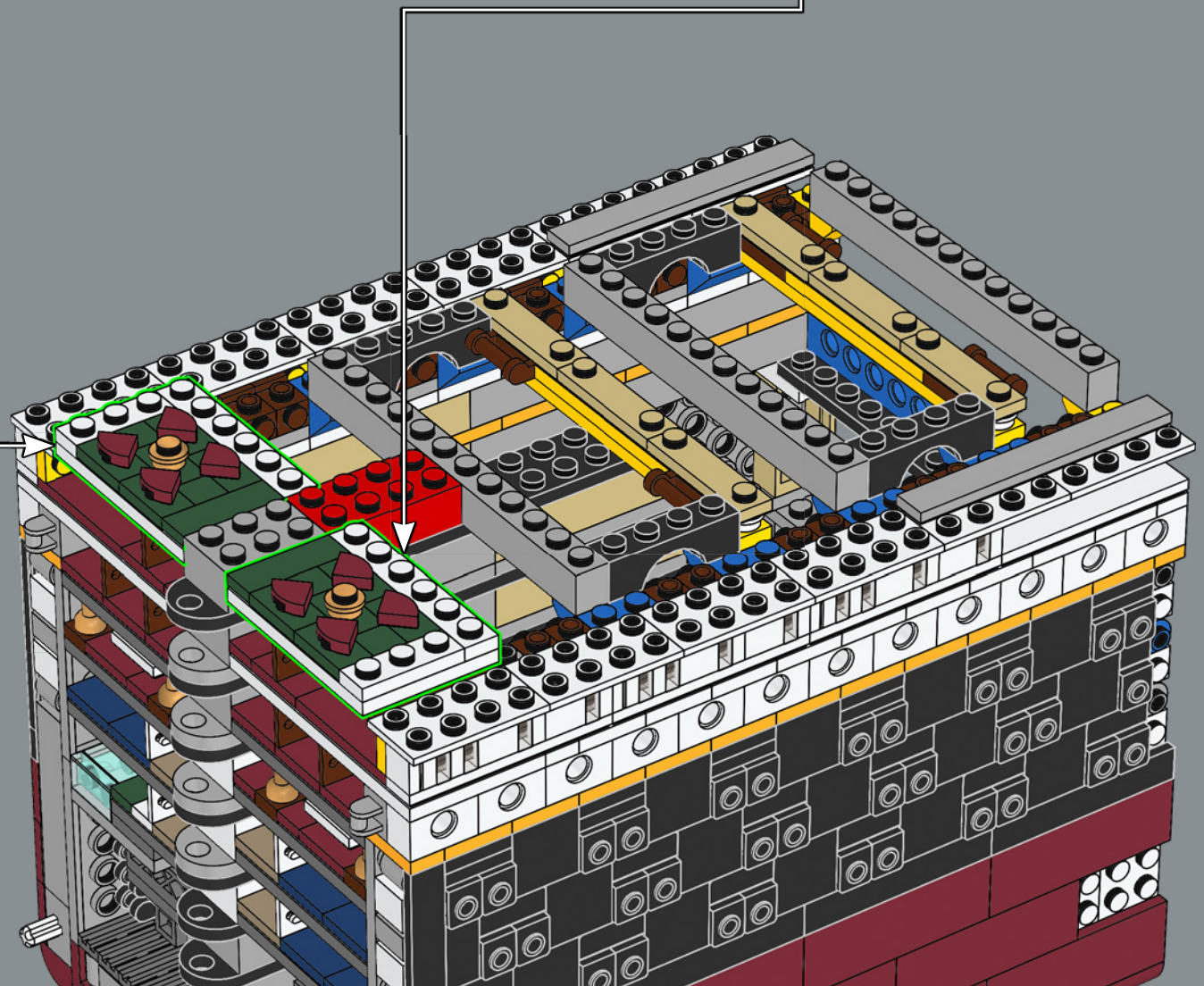
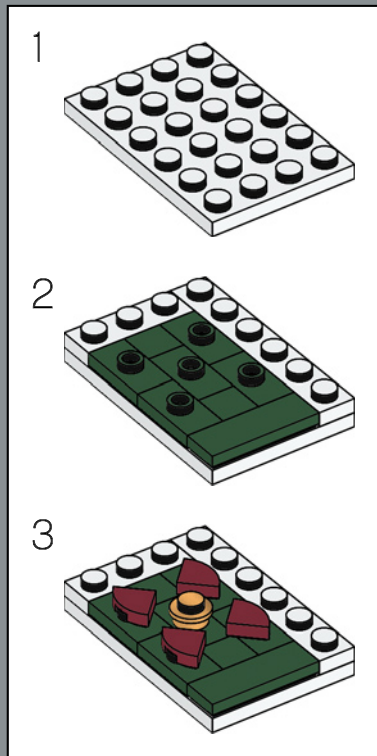

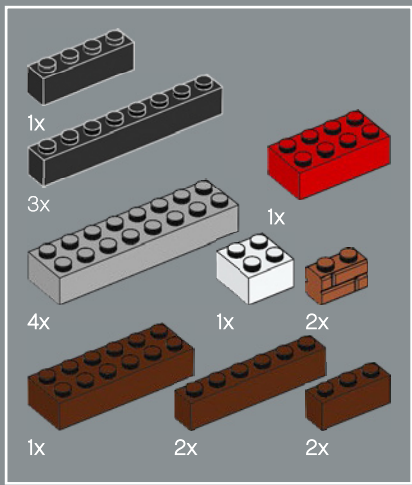

101

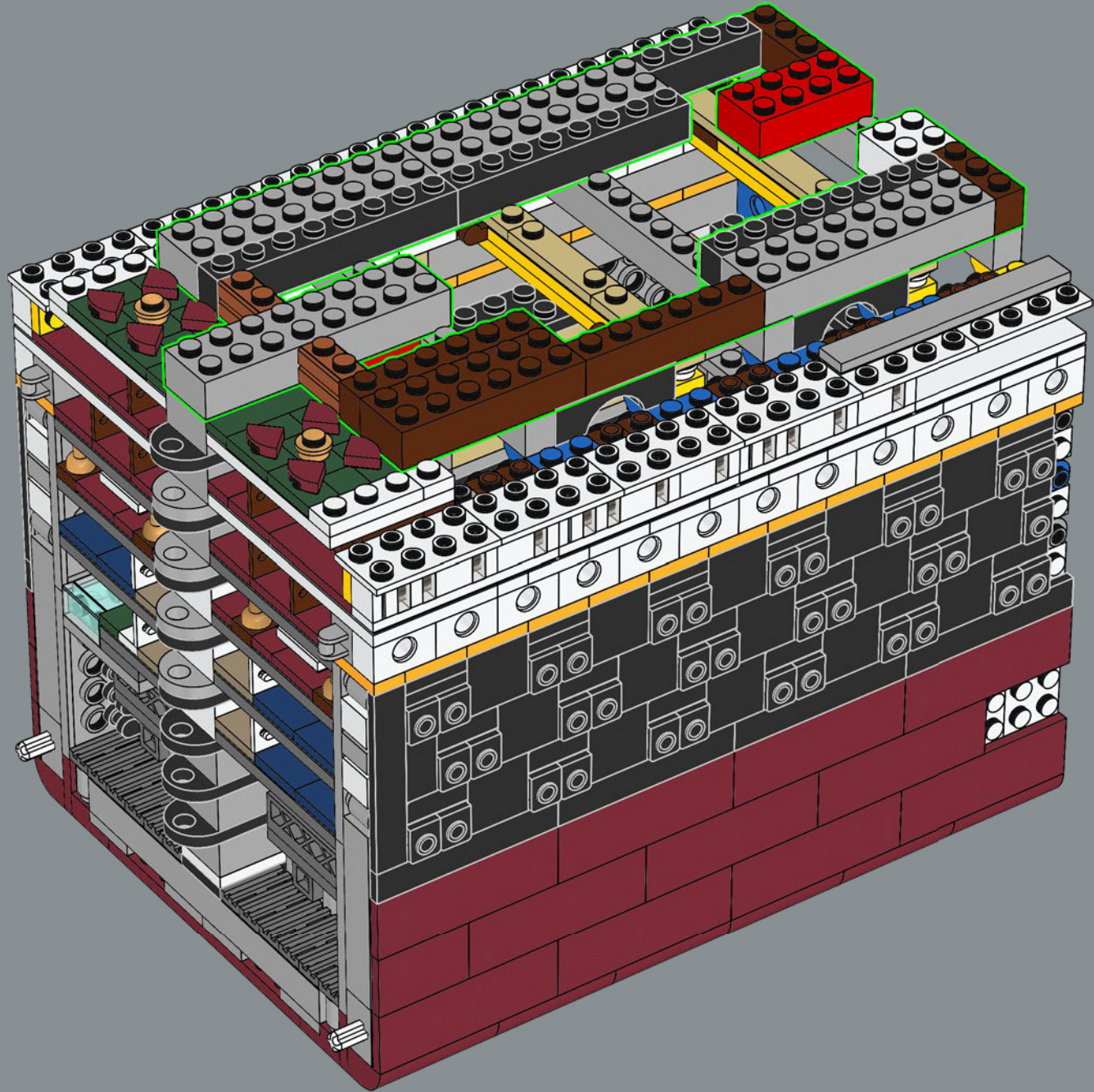

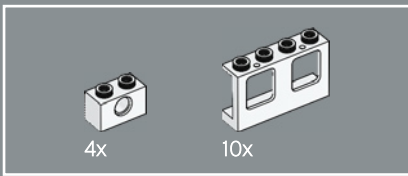

102

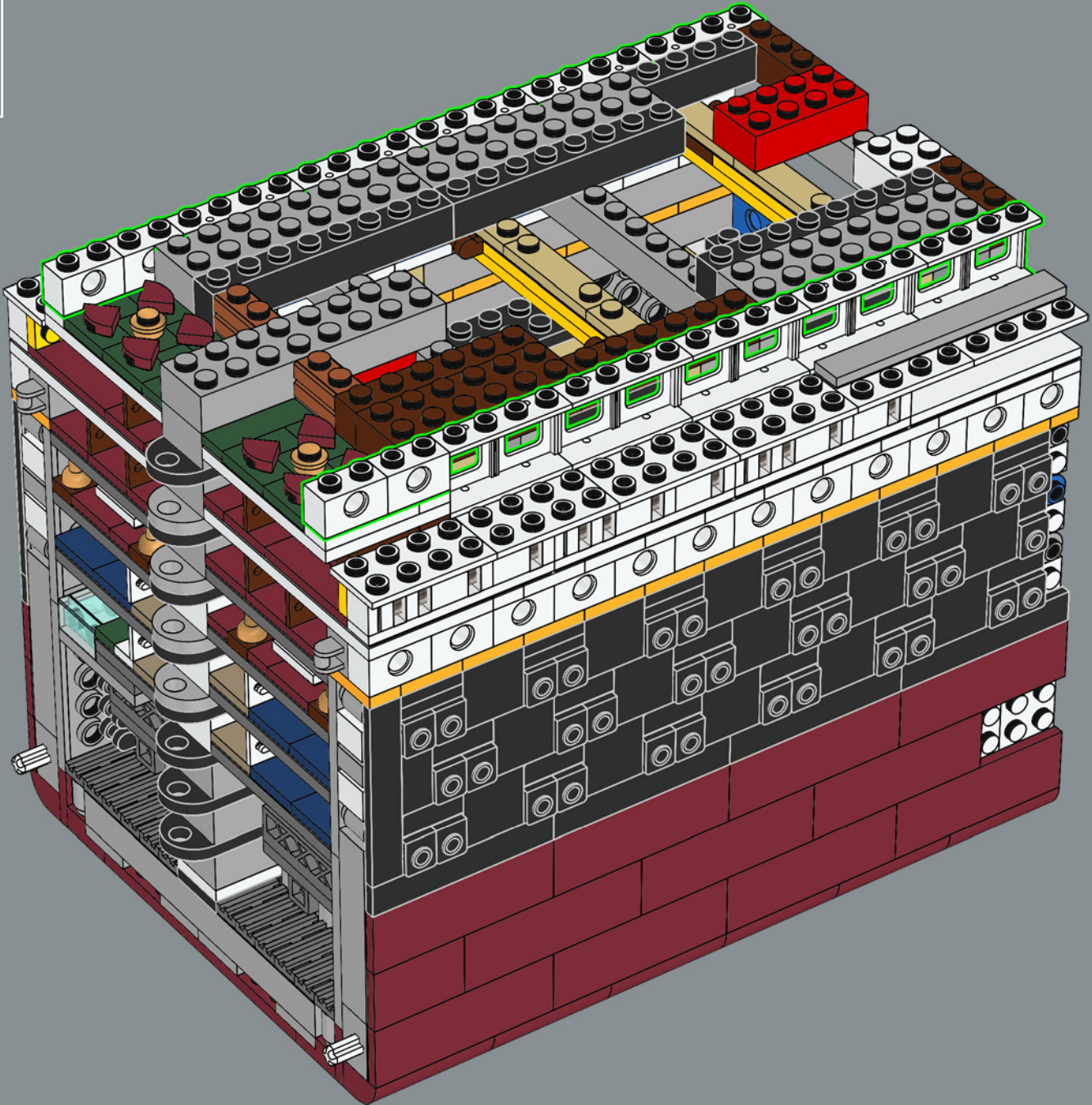

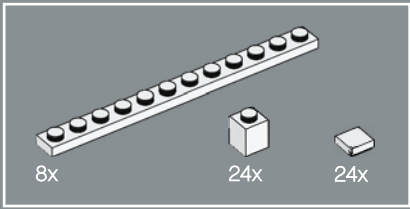

103

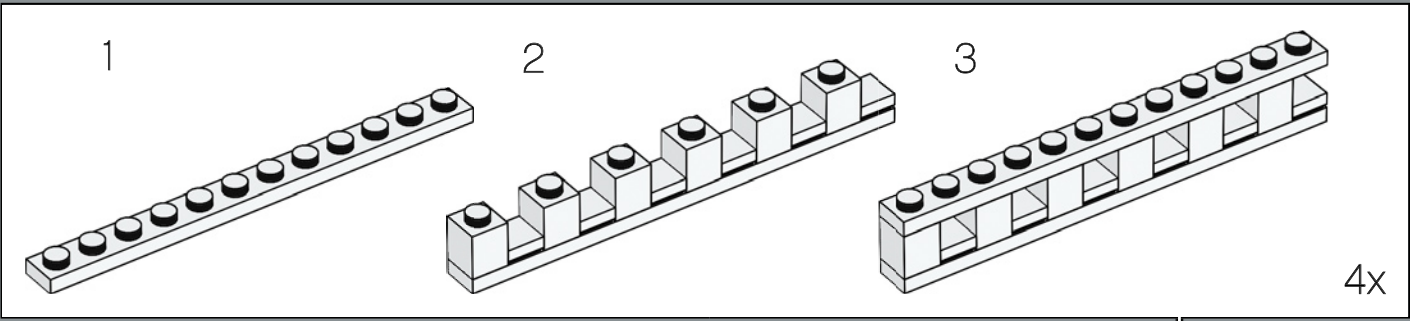

4x

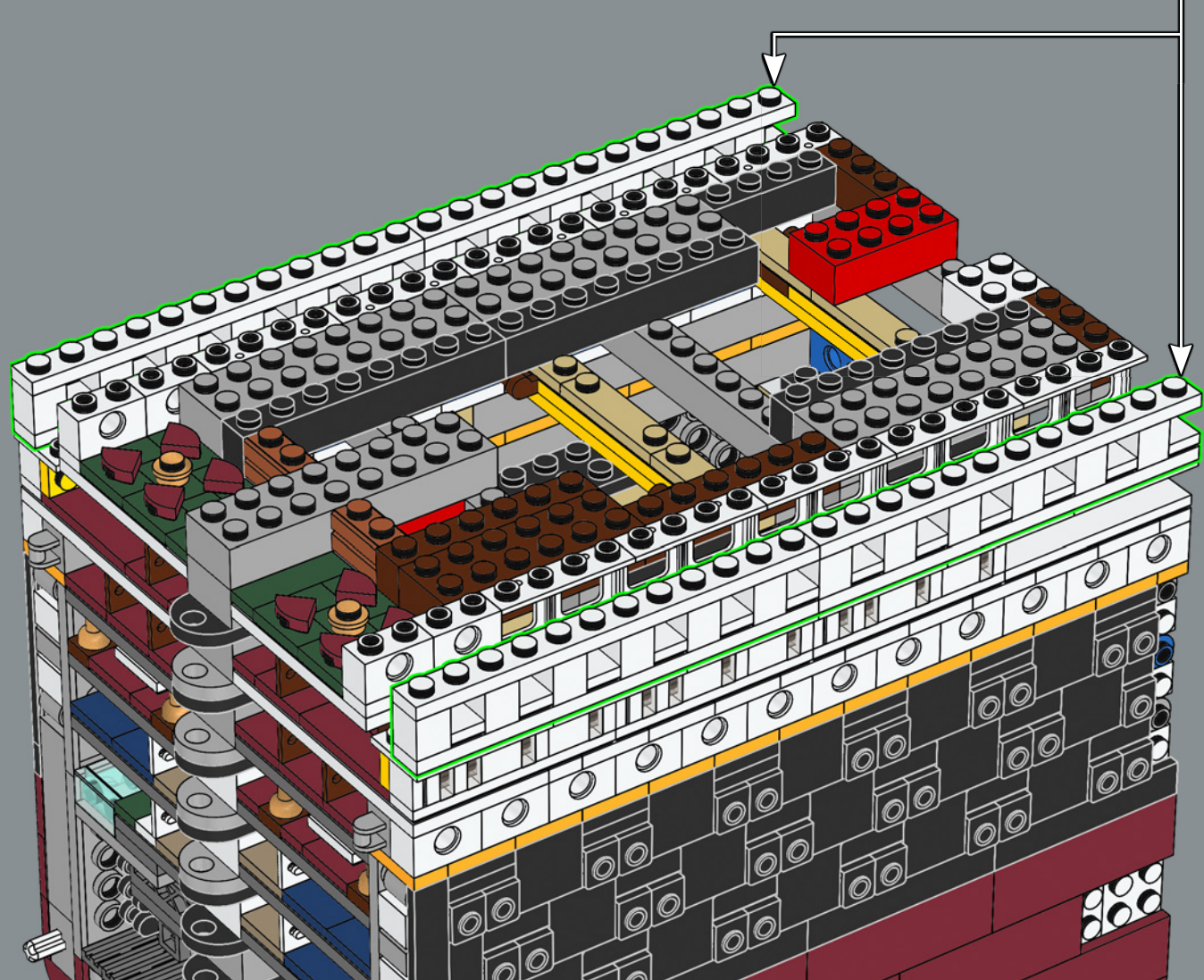

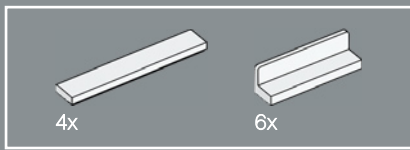

104

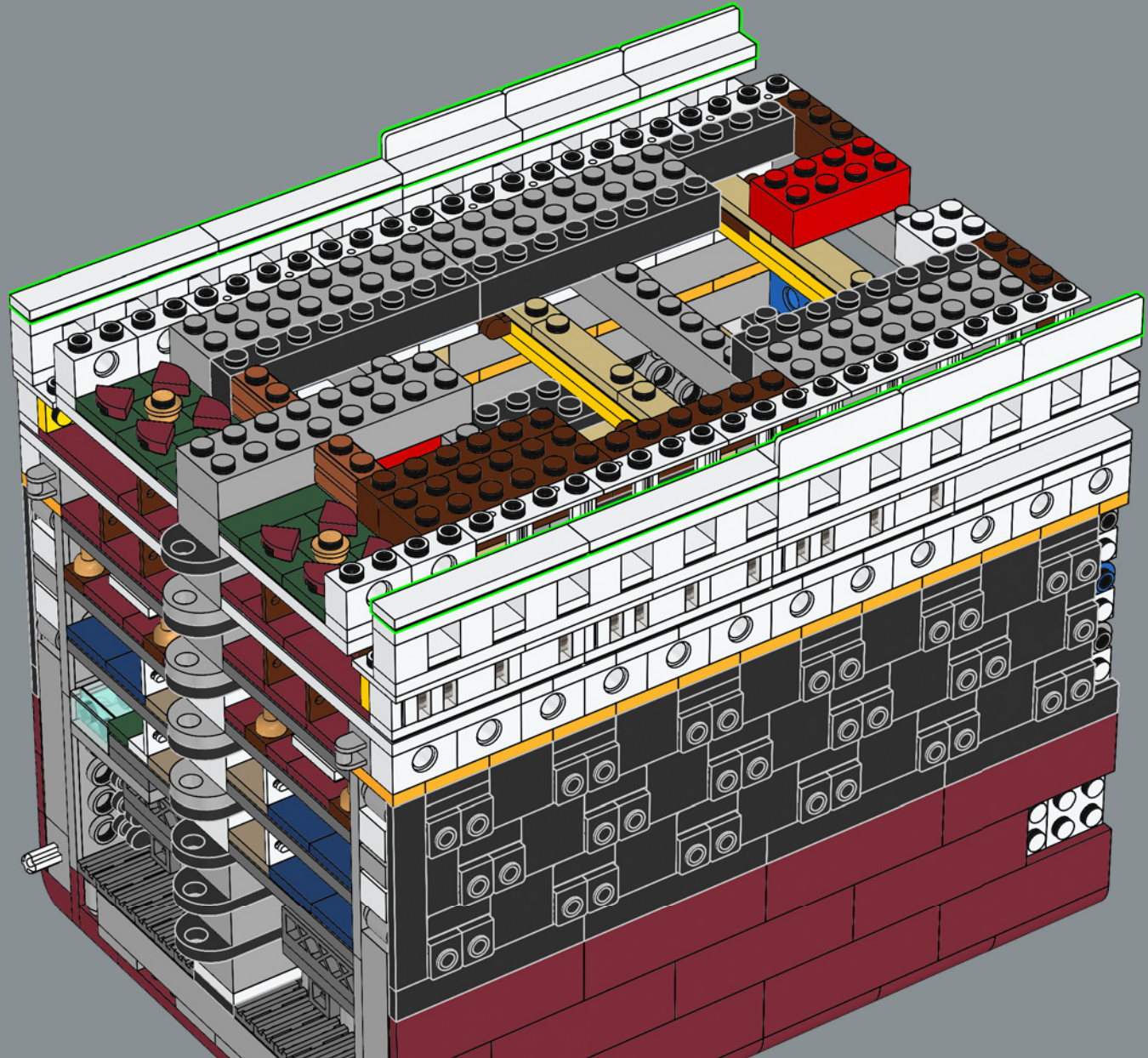

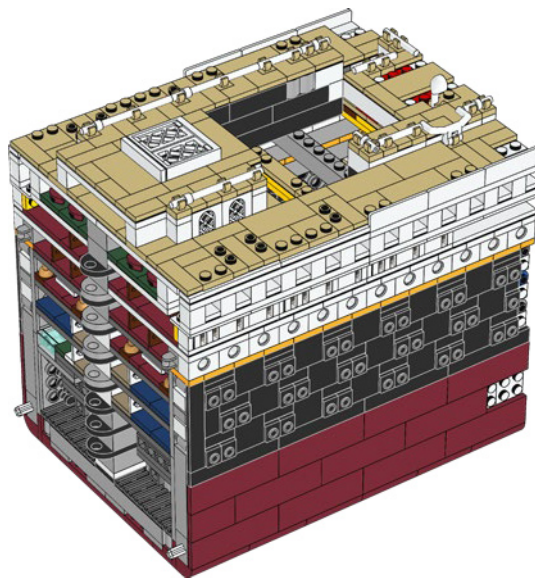
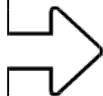

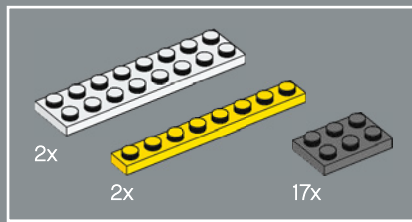

105

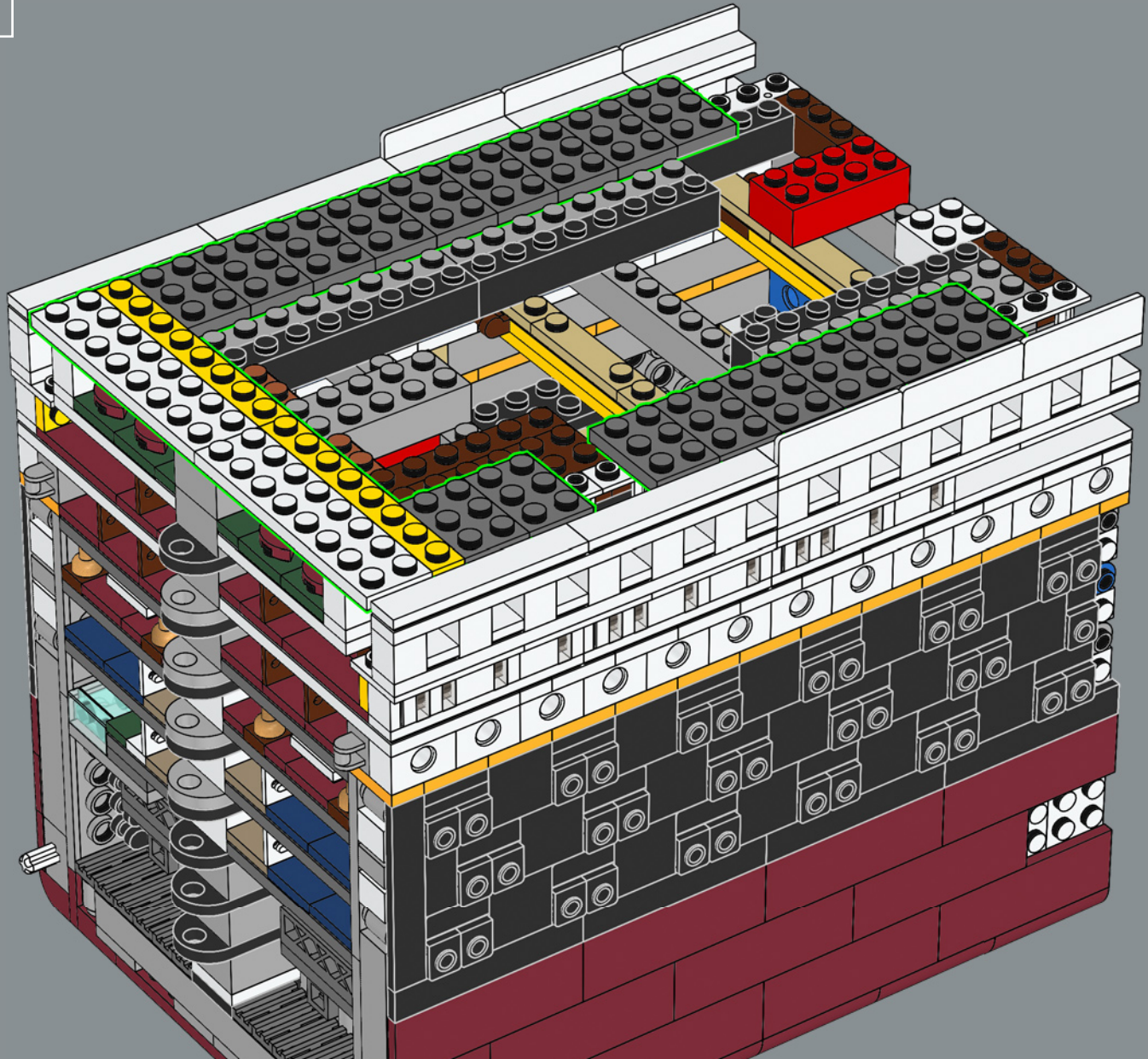

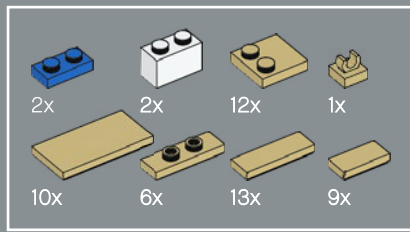

107

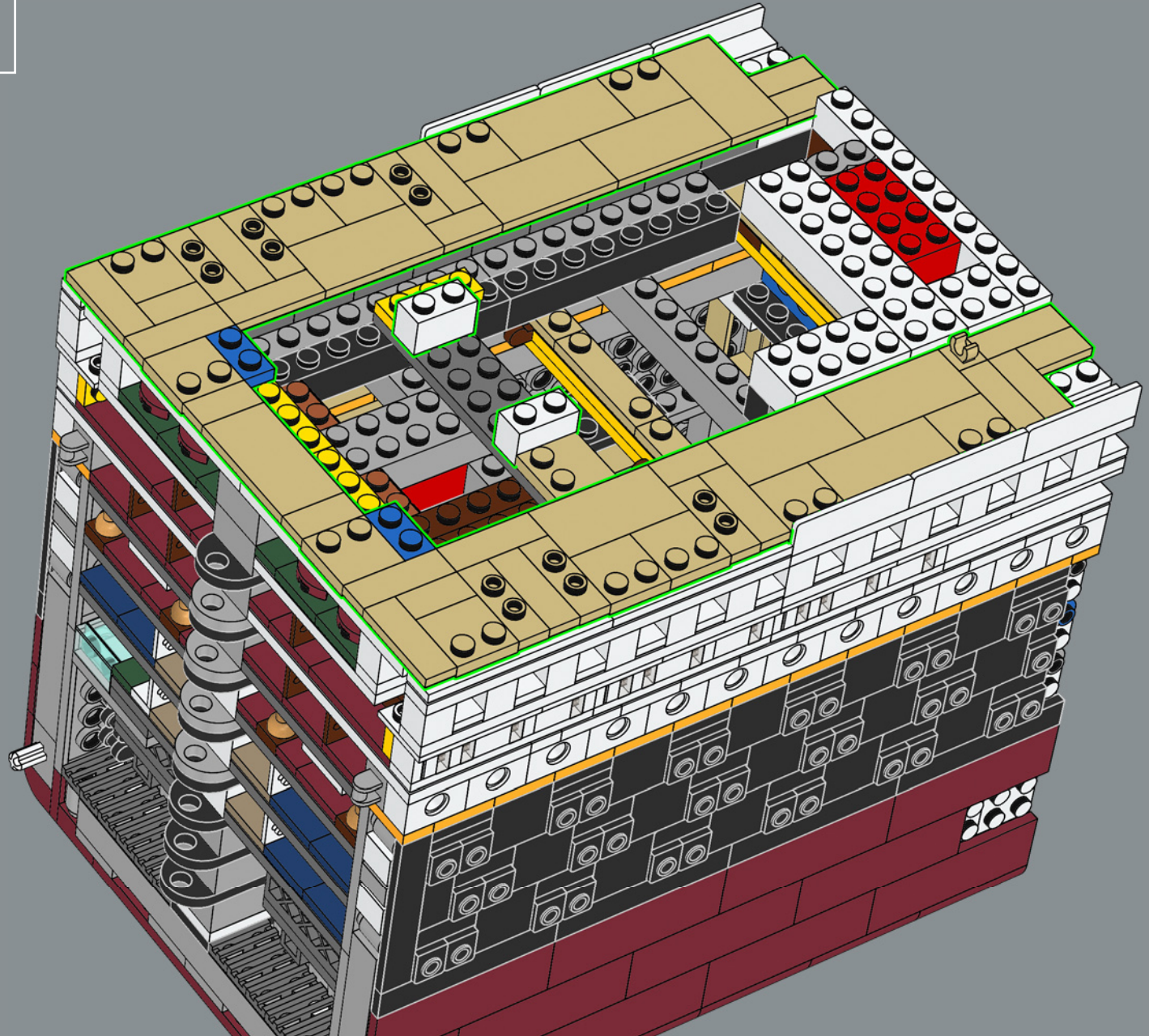

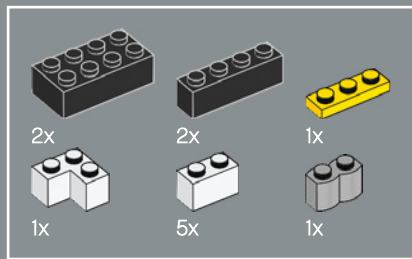

108

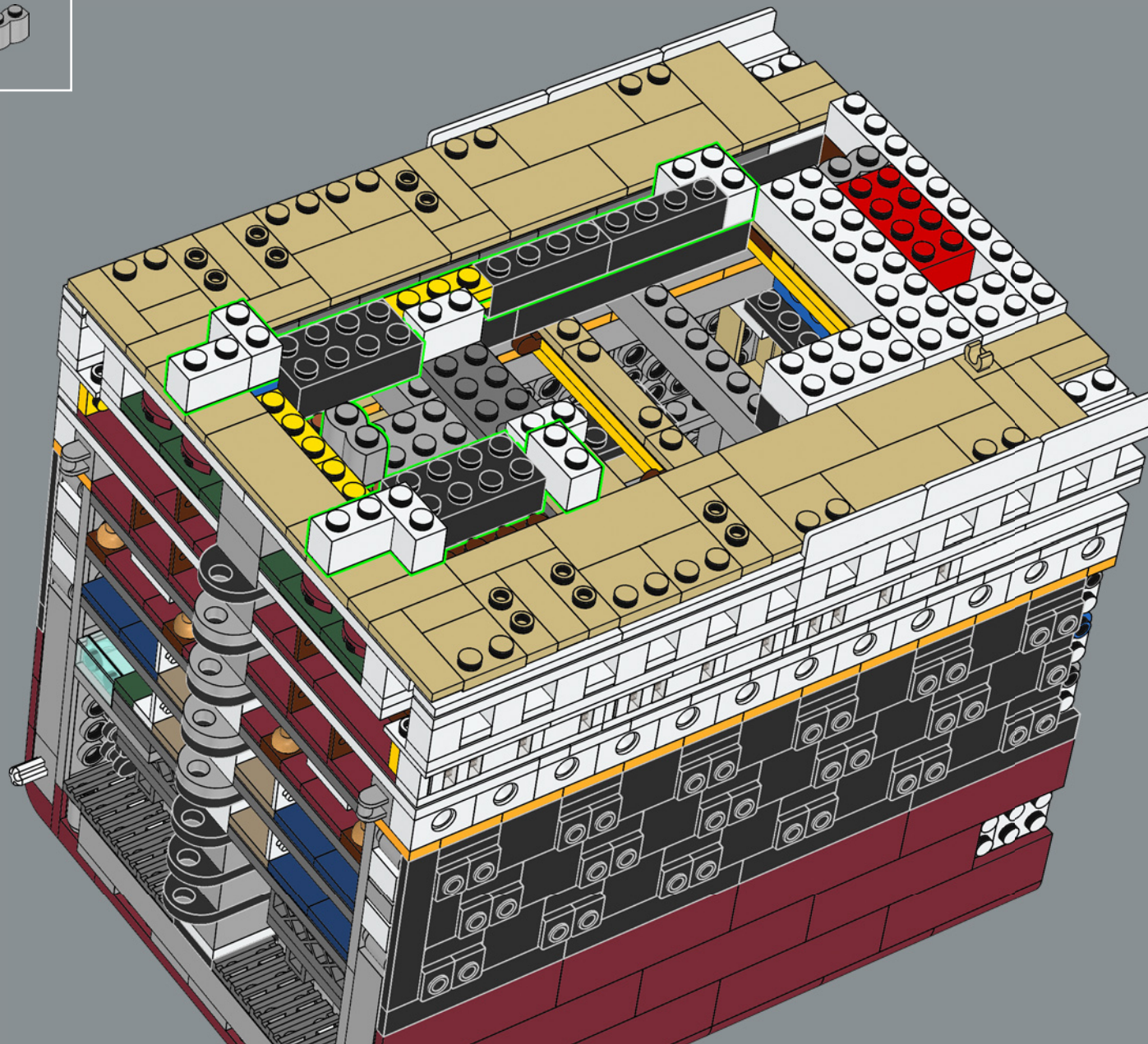

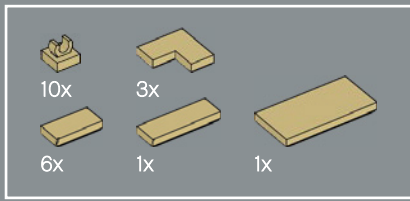

109

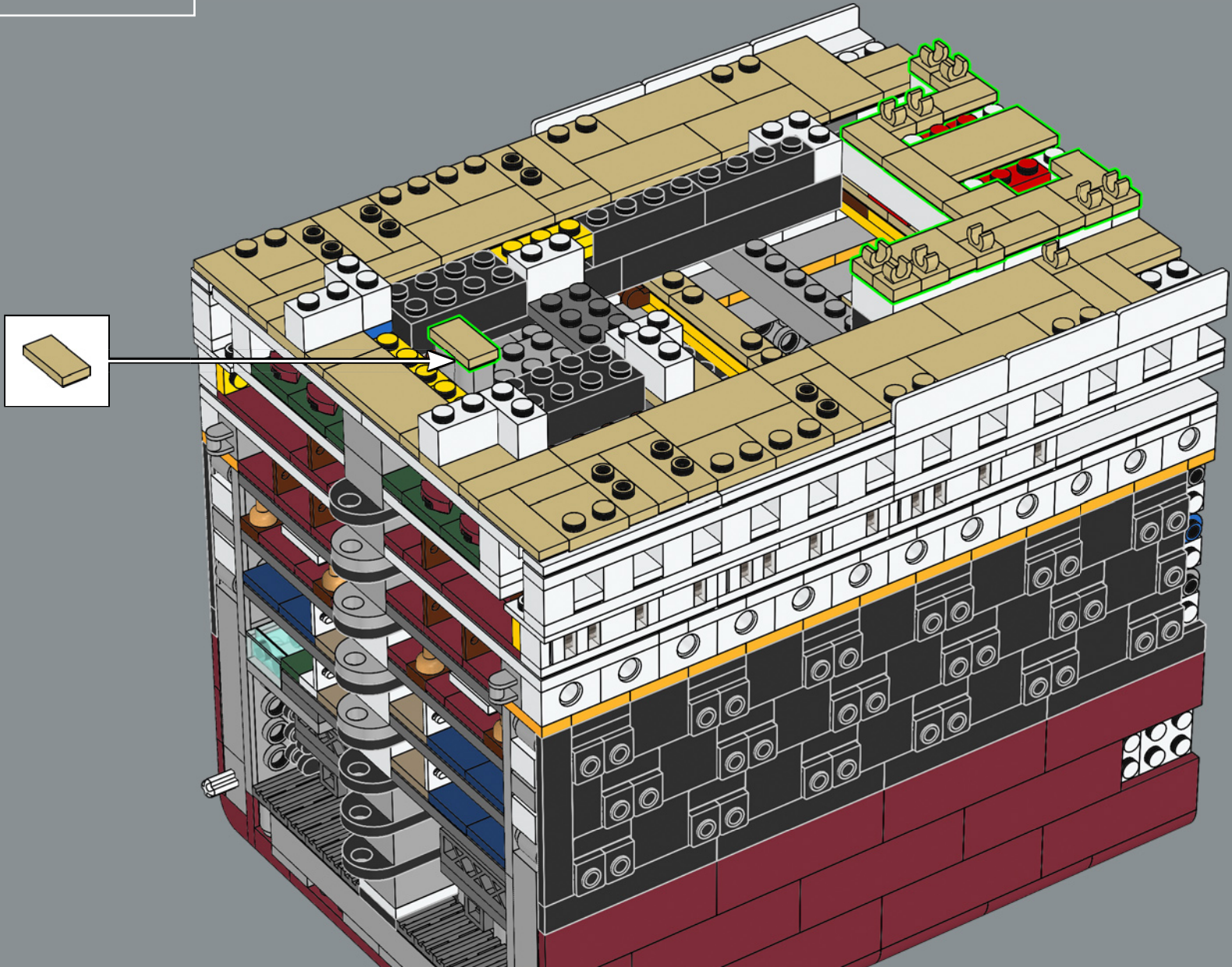

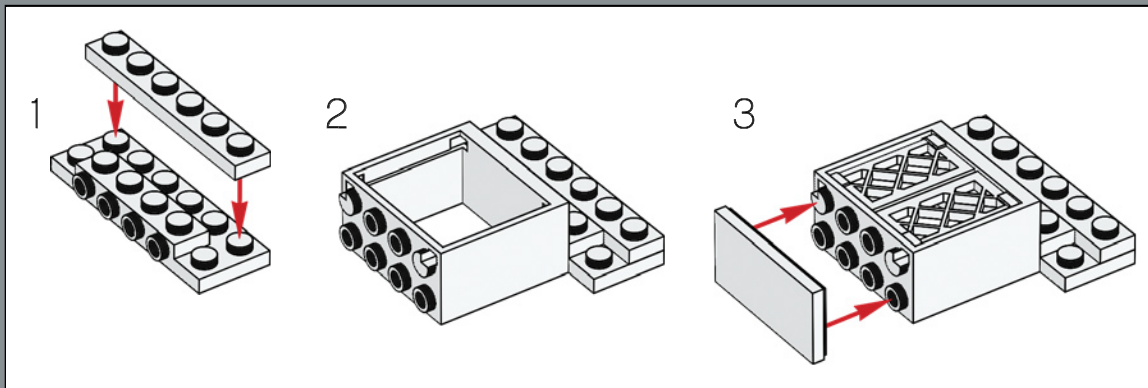
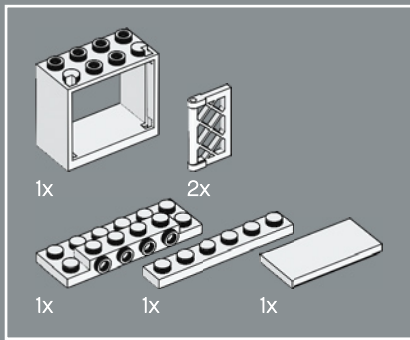

111

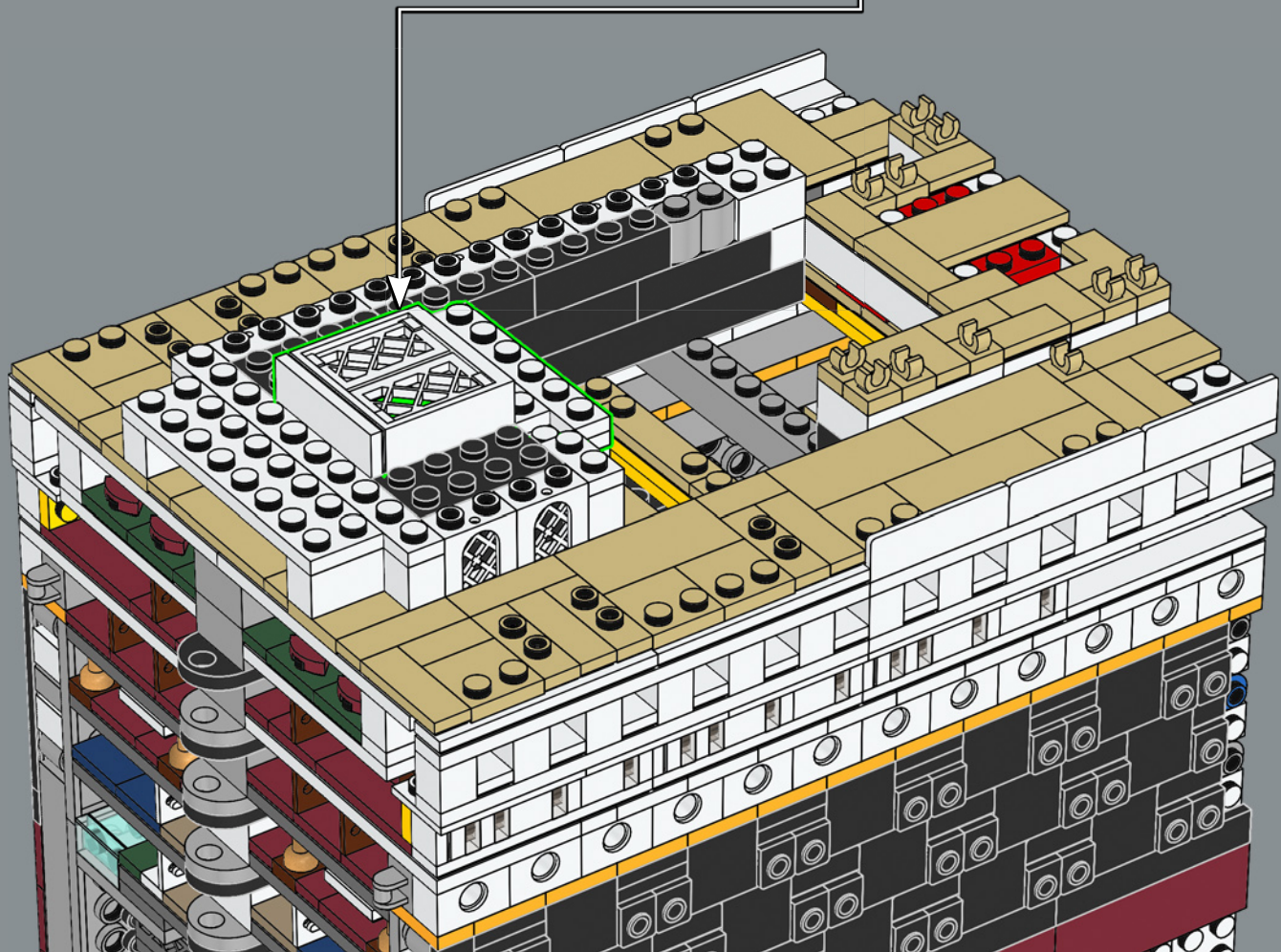

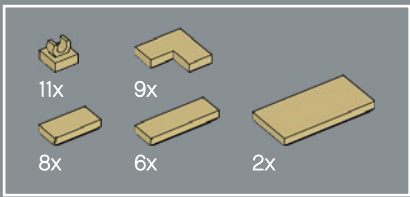

112

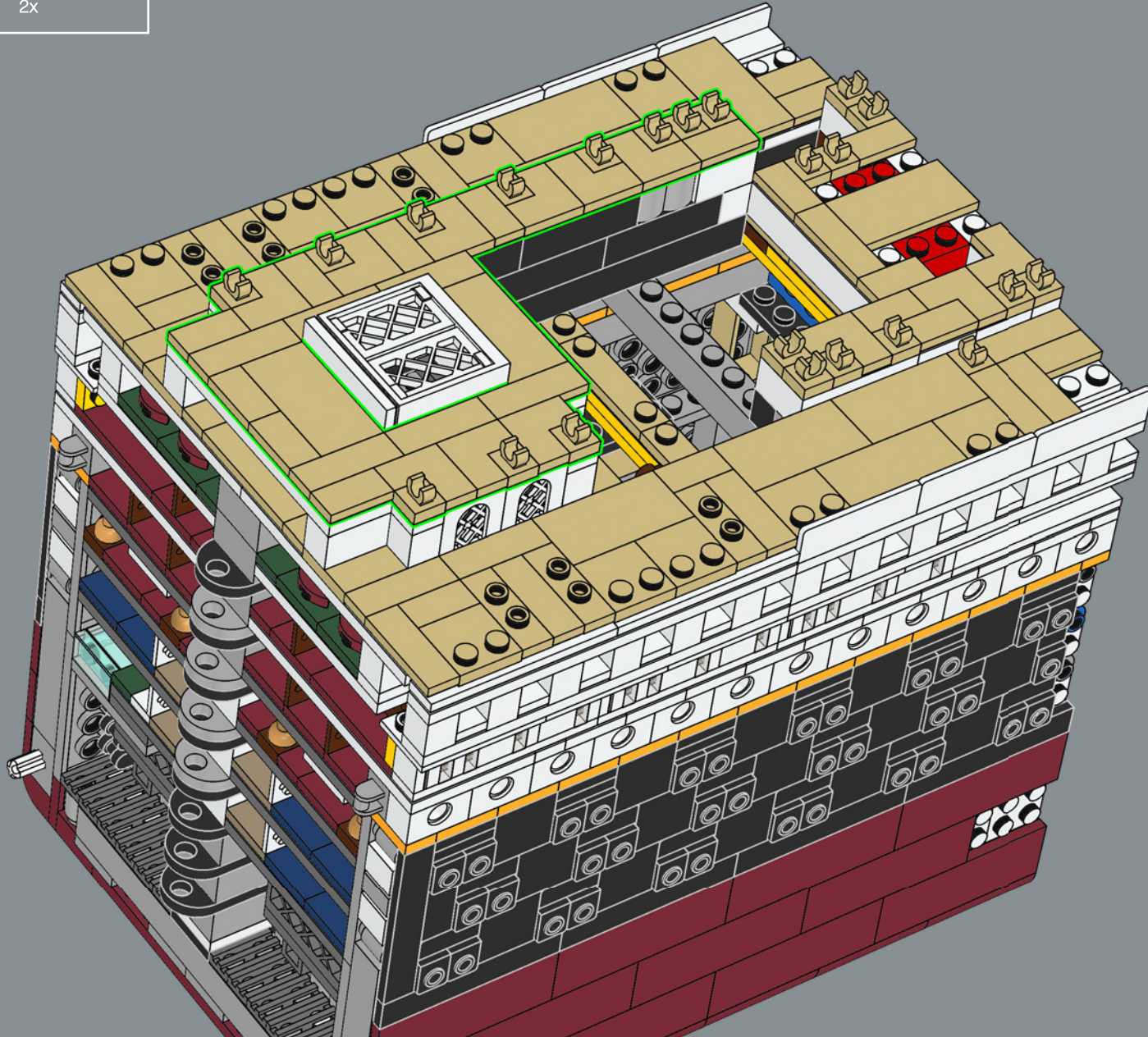

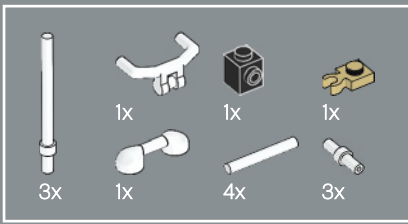

113

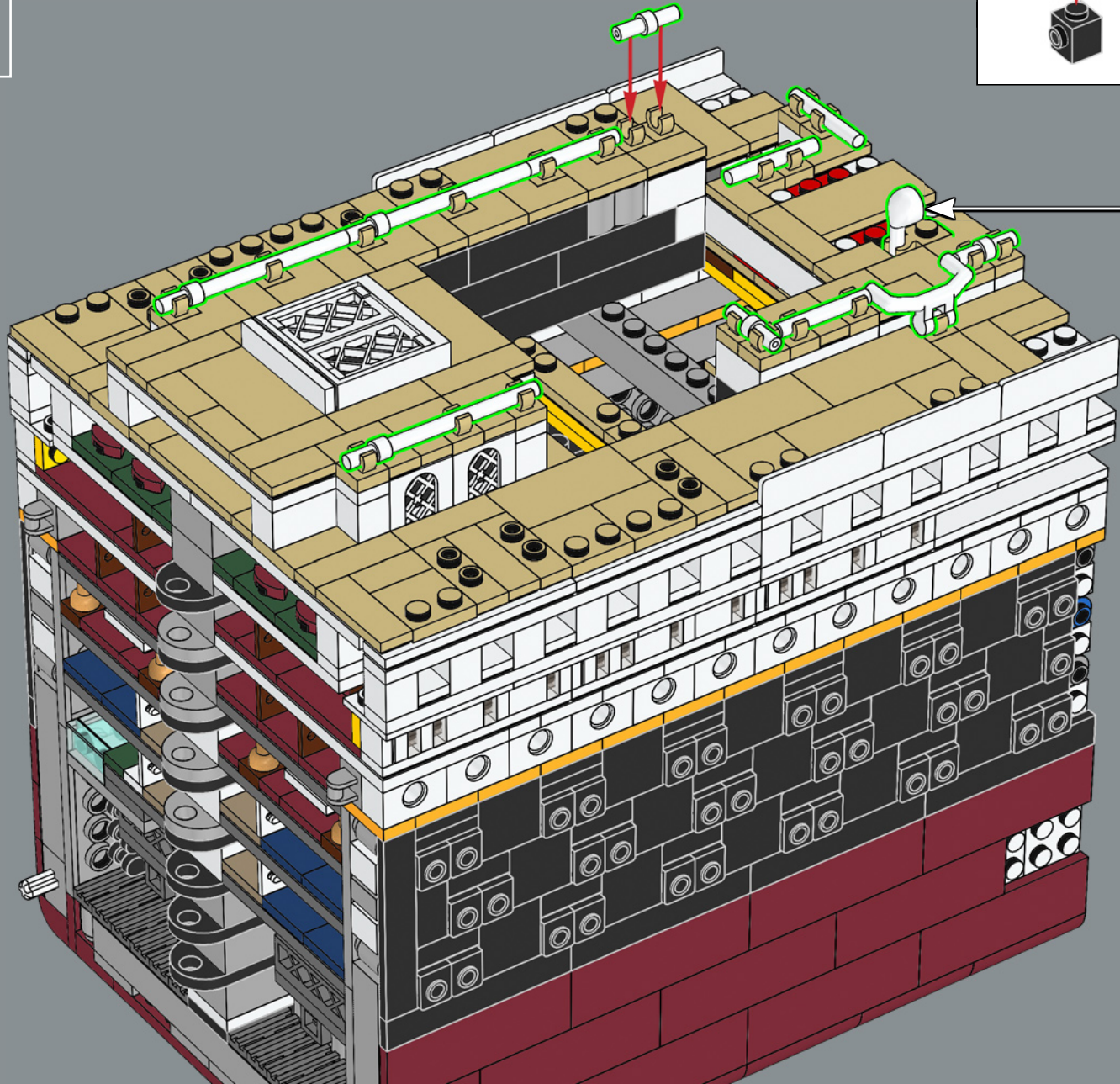
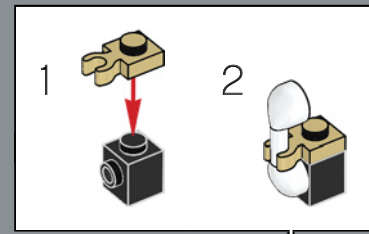

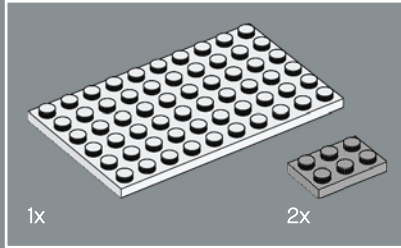
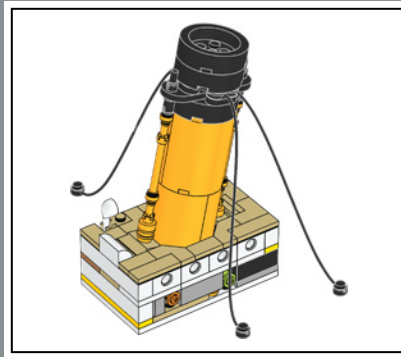
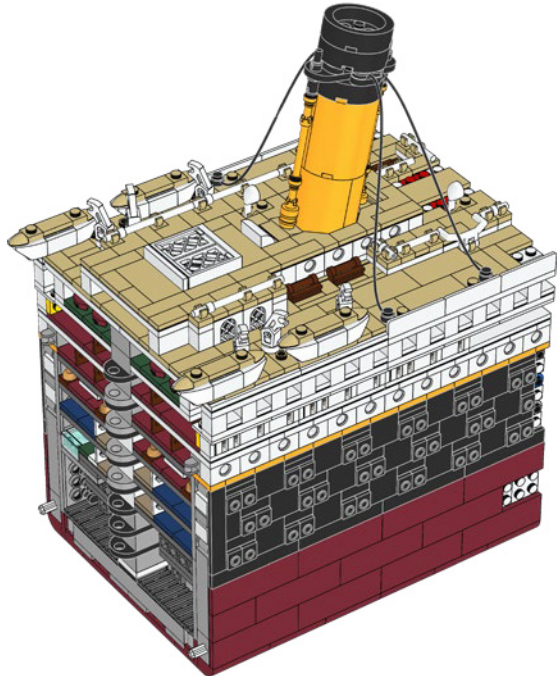
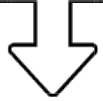

114

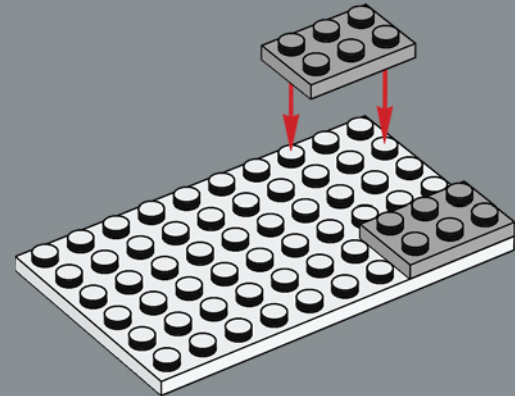

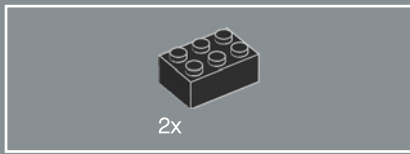

115

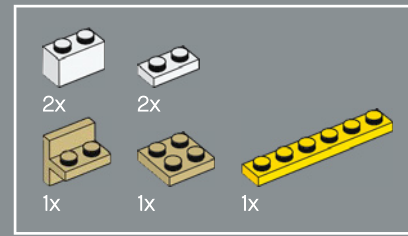
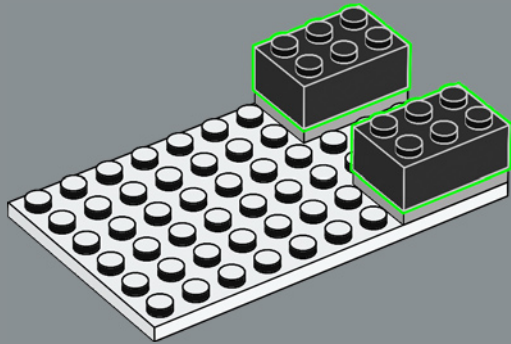

116

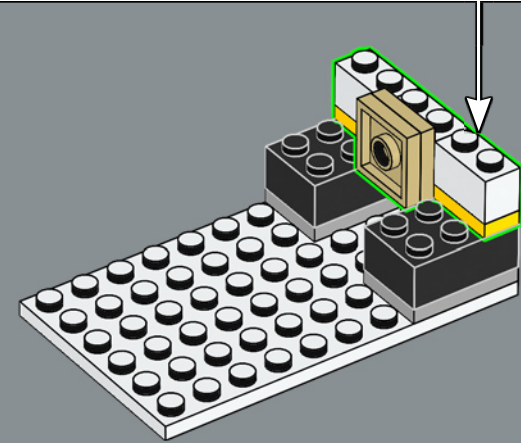
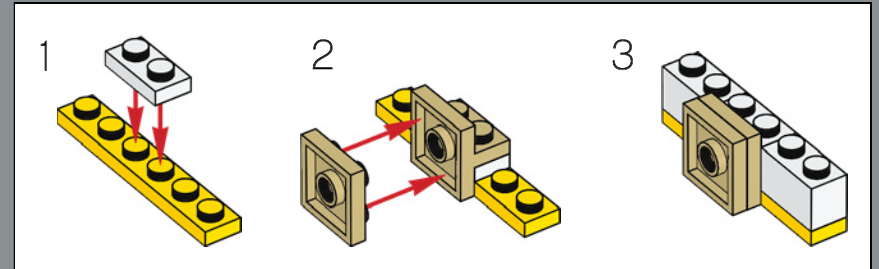

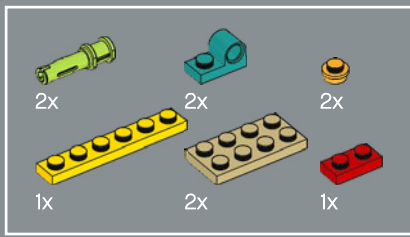

117

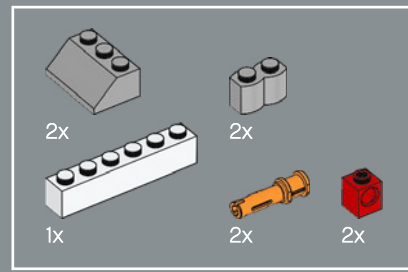
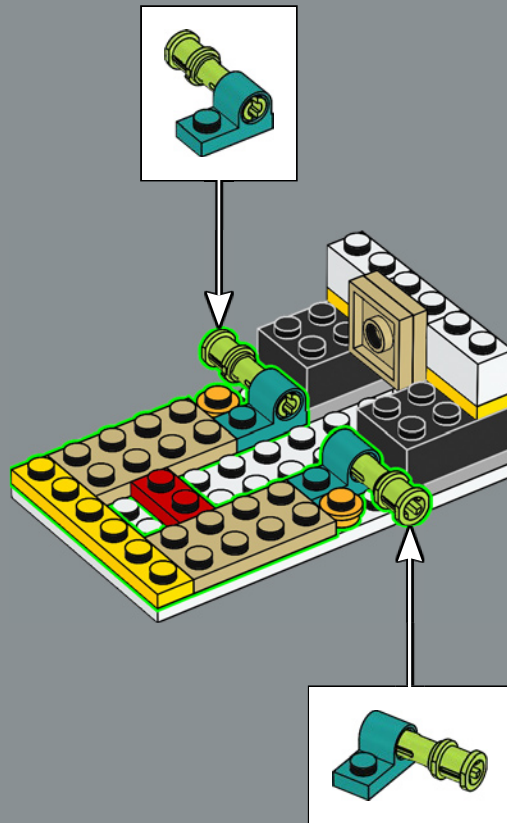

118

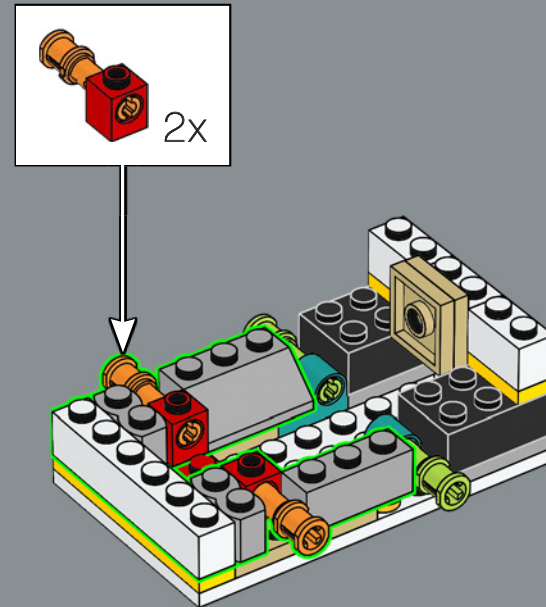

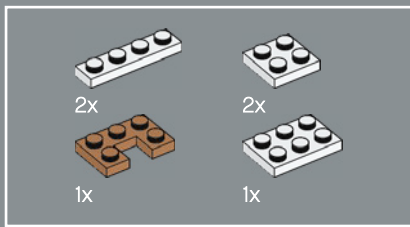

119

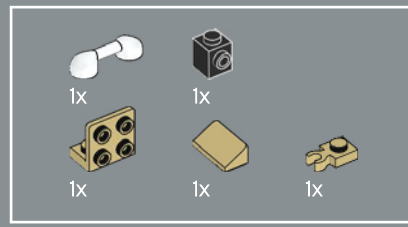
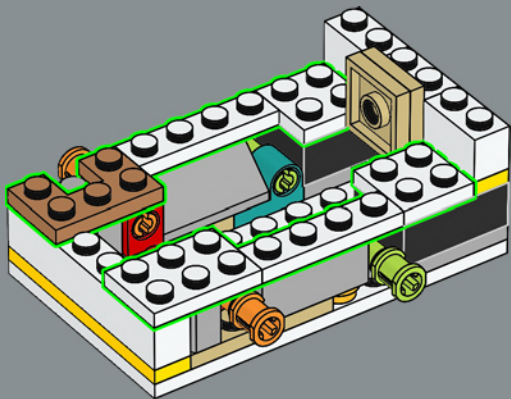

120

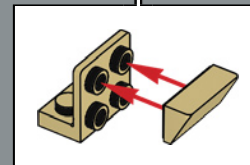
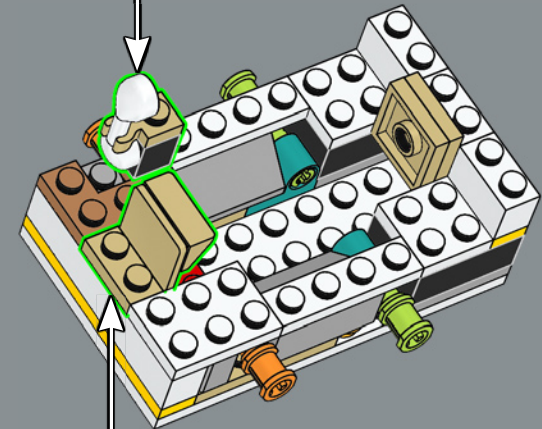
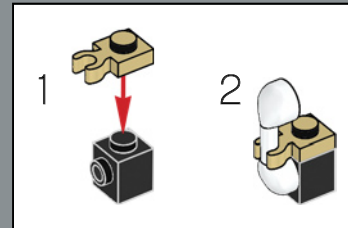

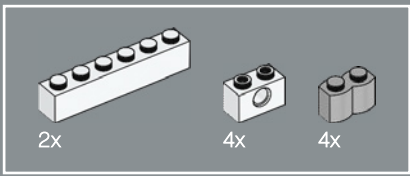

121

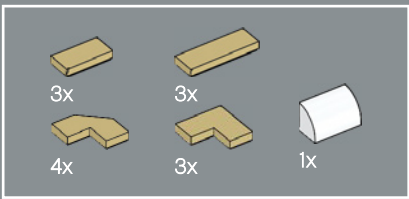
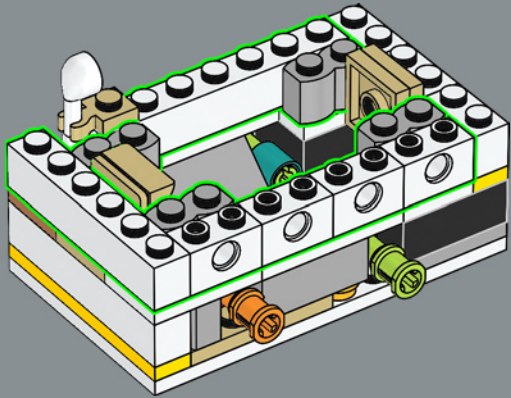

122

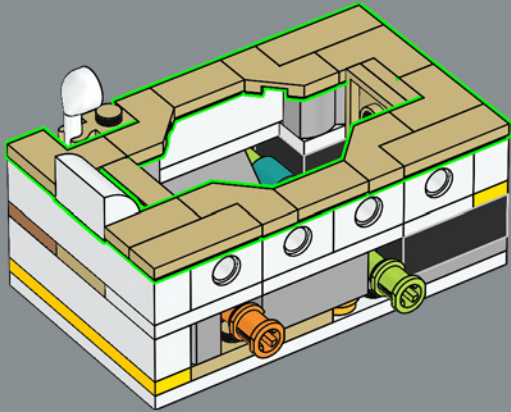

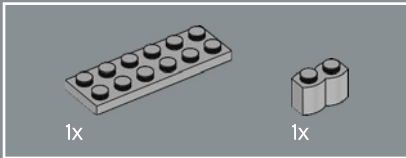
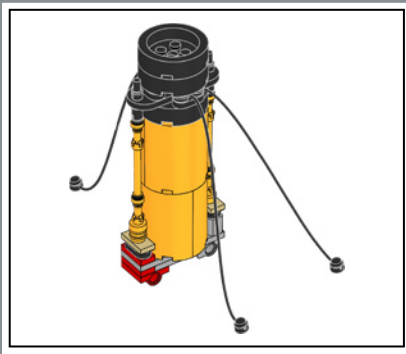

123

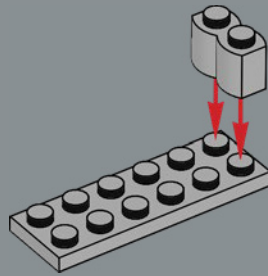

124

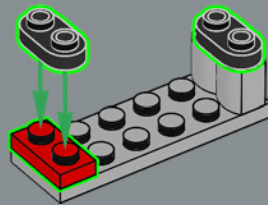

125

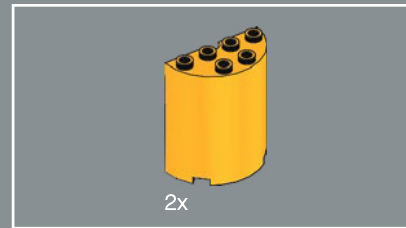
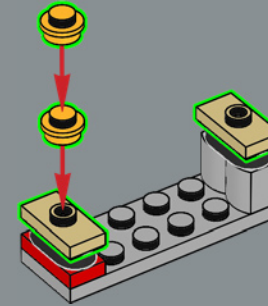

126

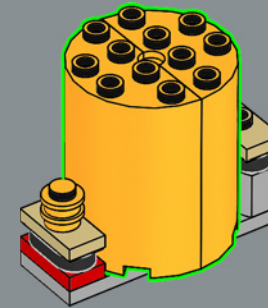

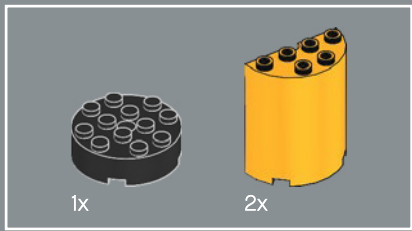

127

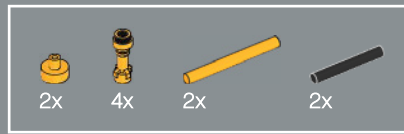
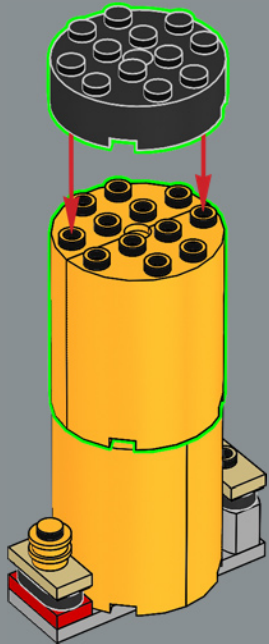

128

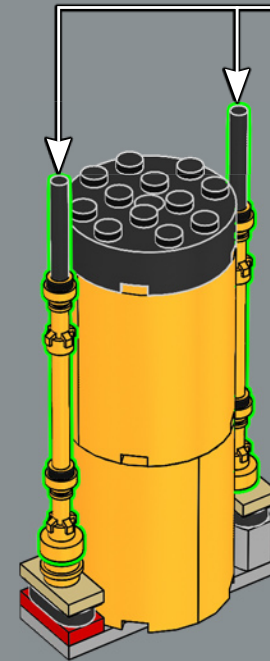
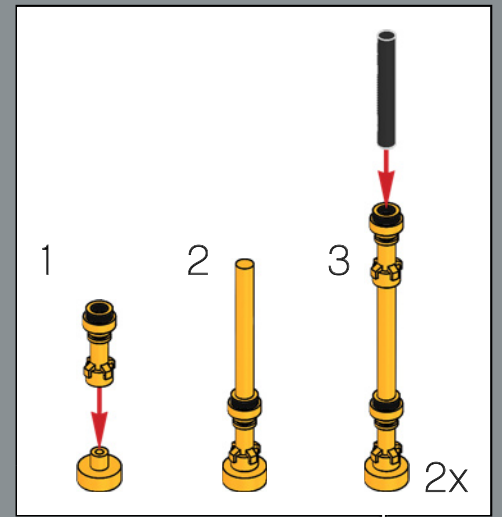

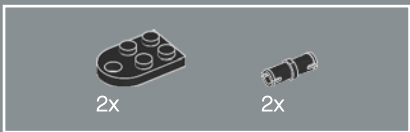

129

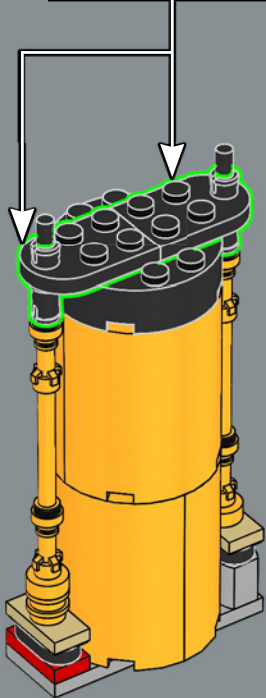
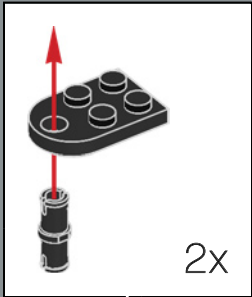

130

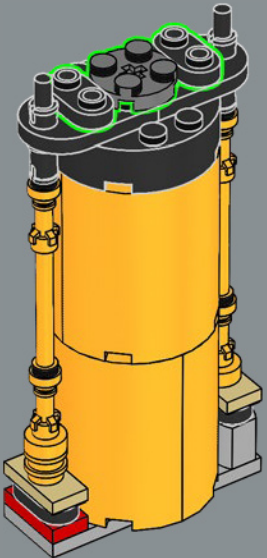



131

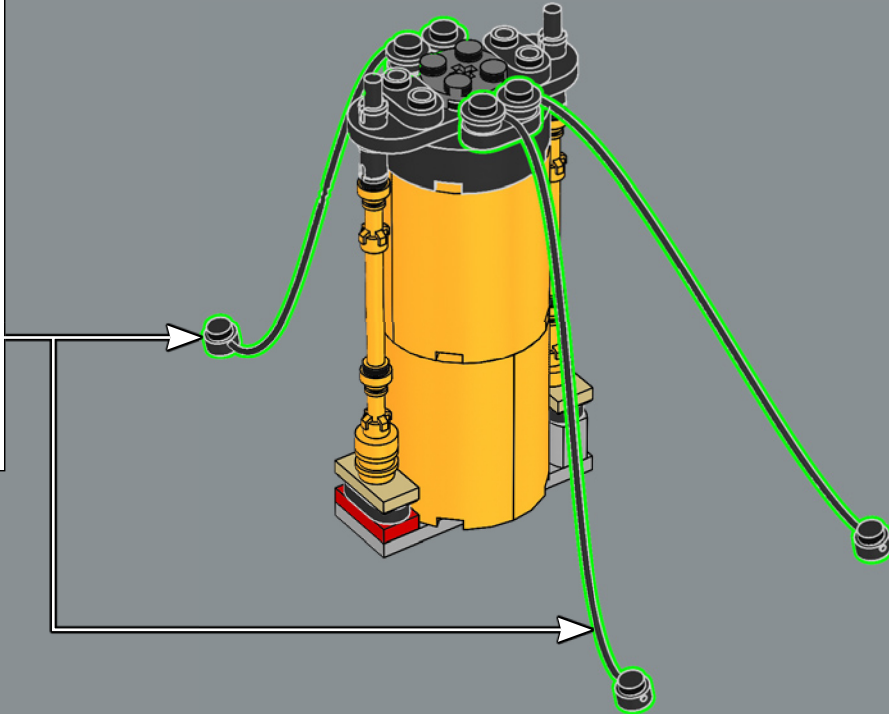
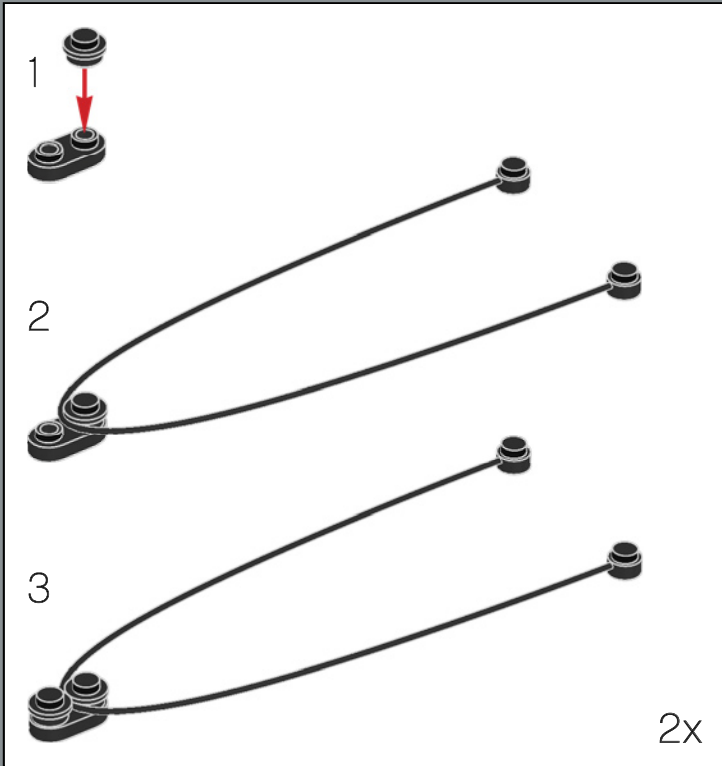

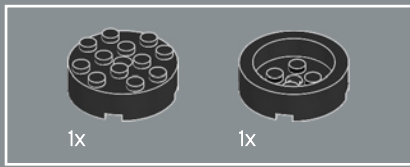

132

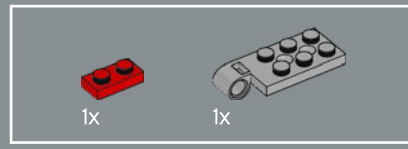
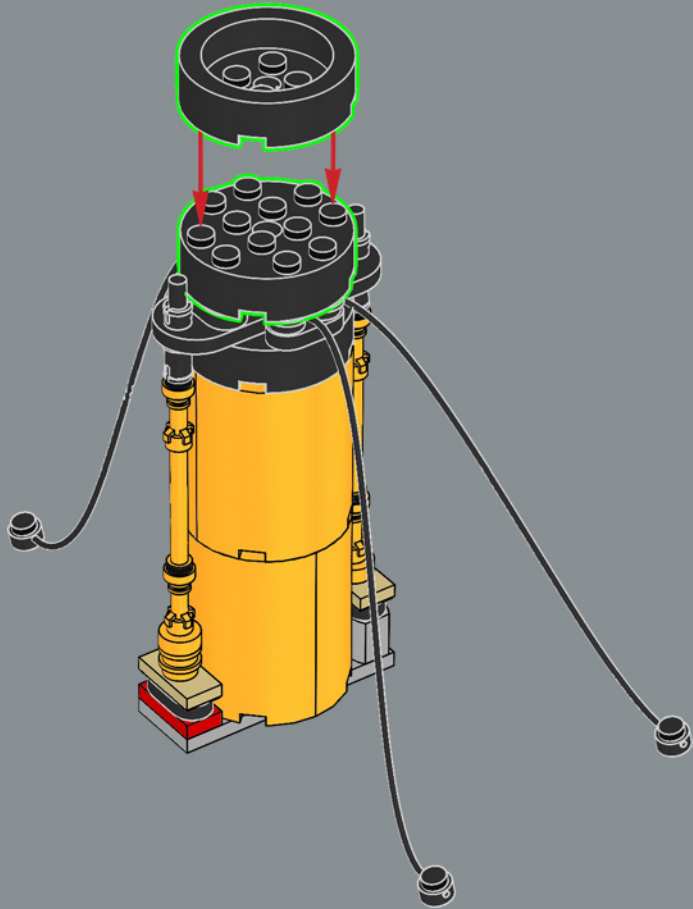

133

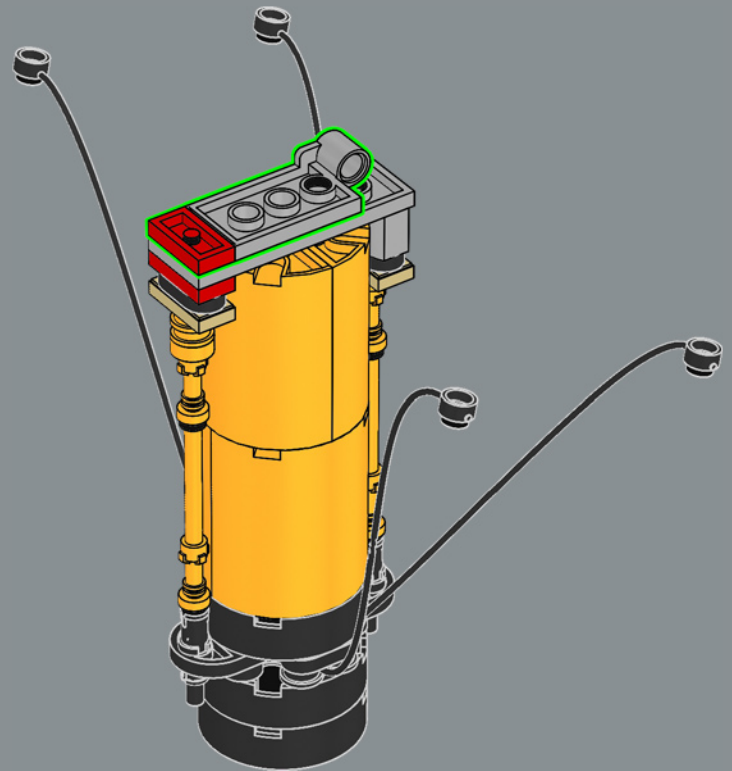

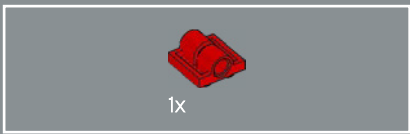

134

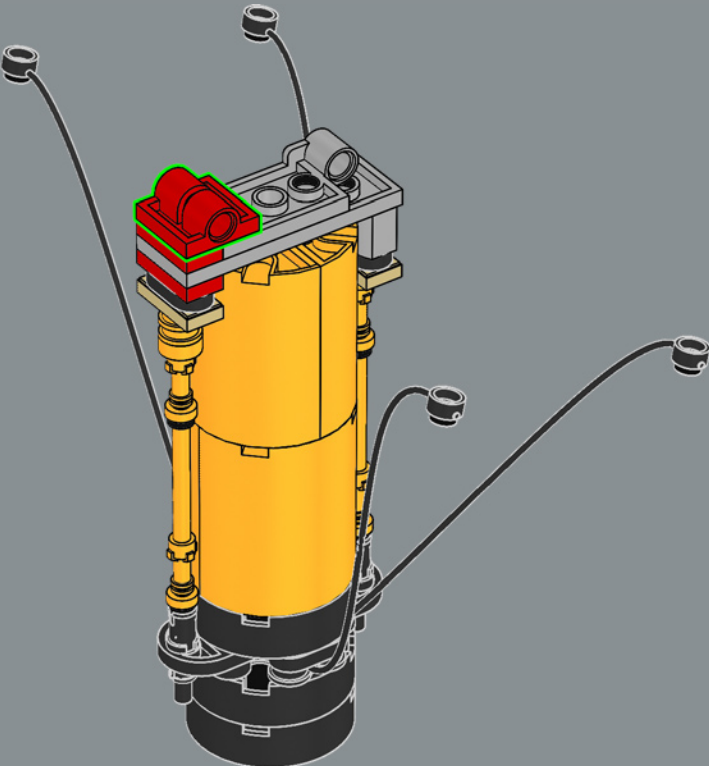

135

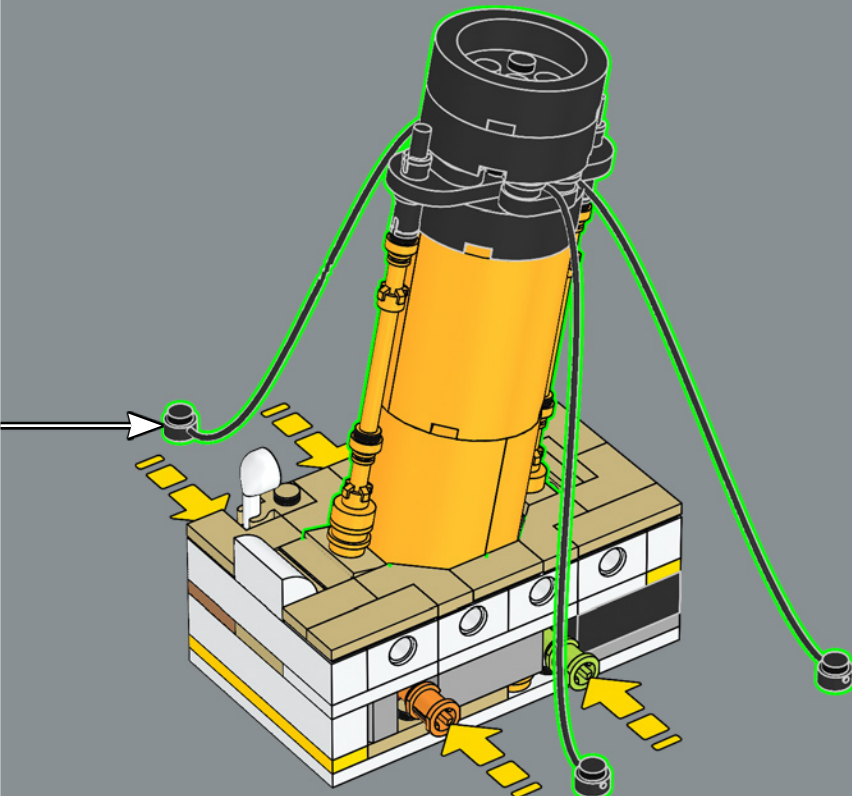

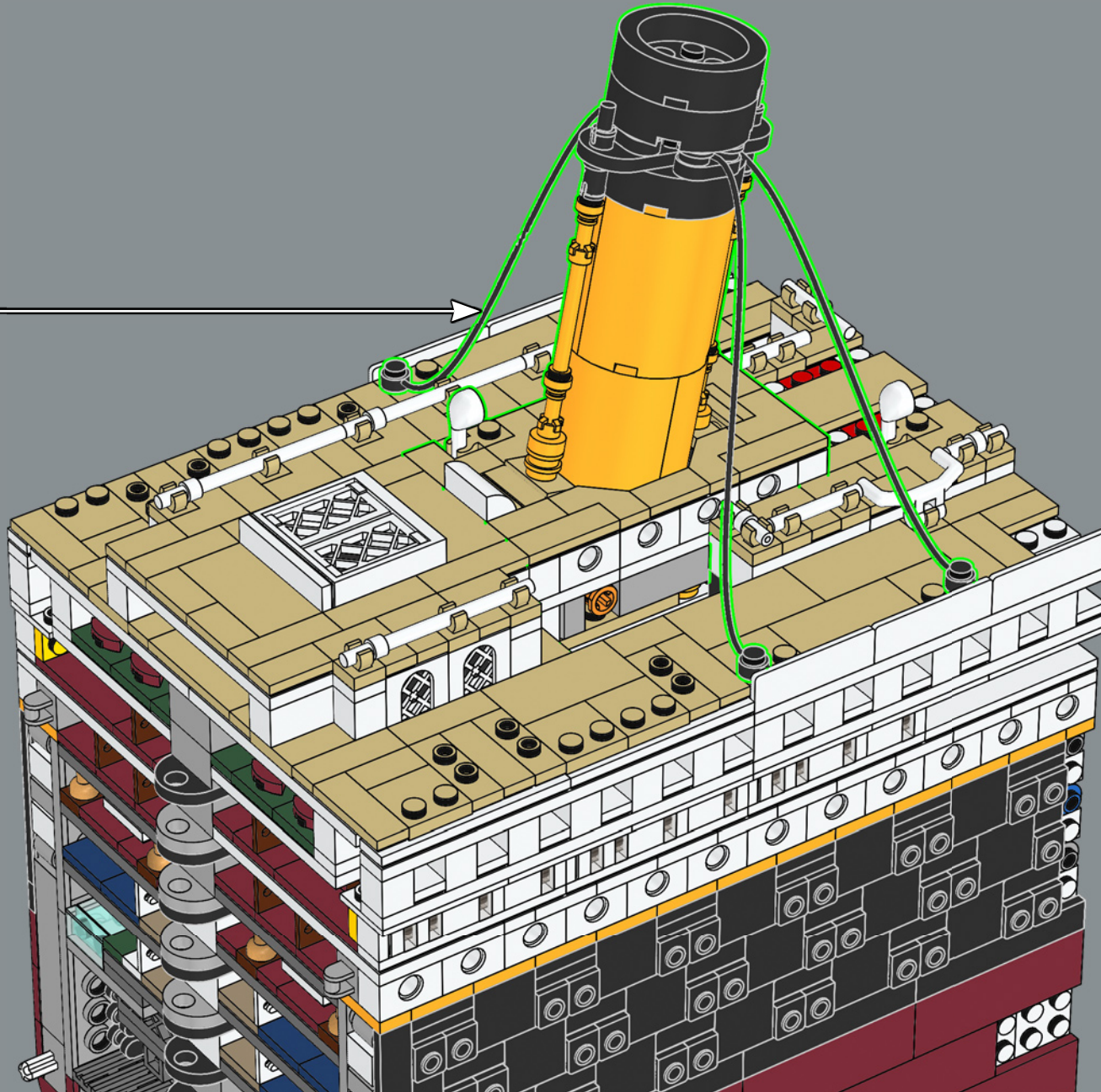

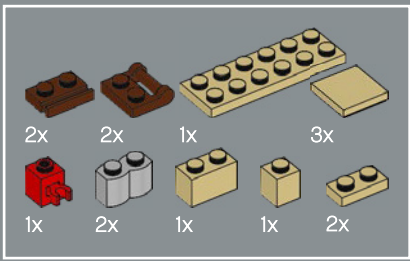

137

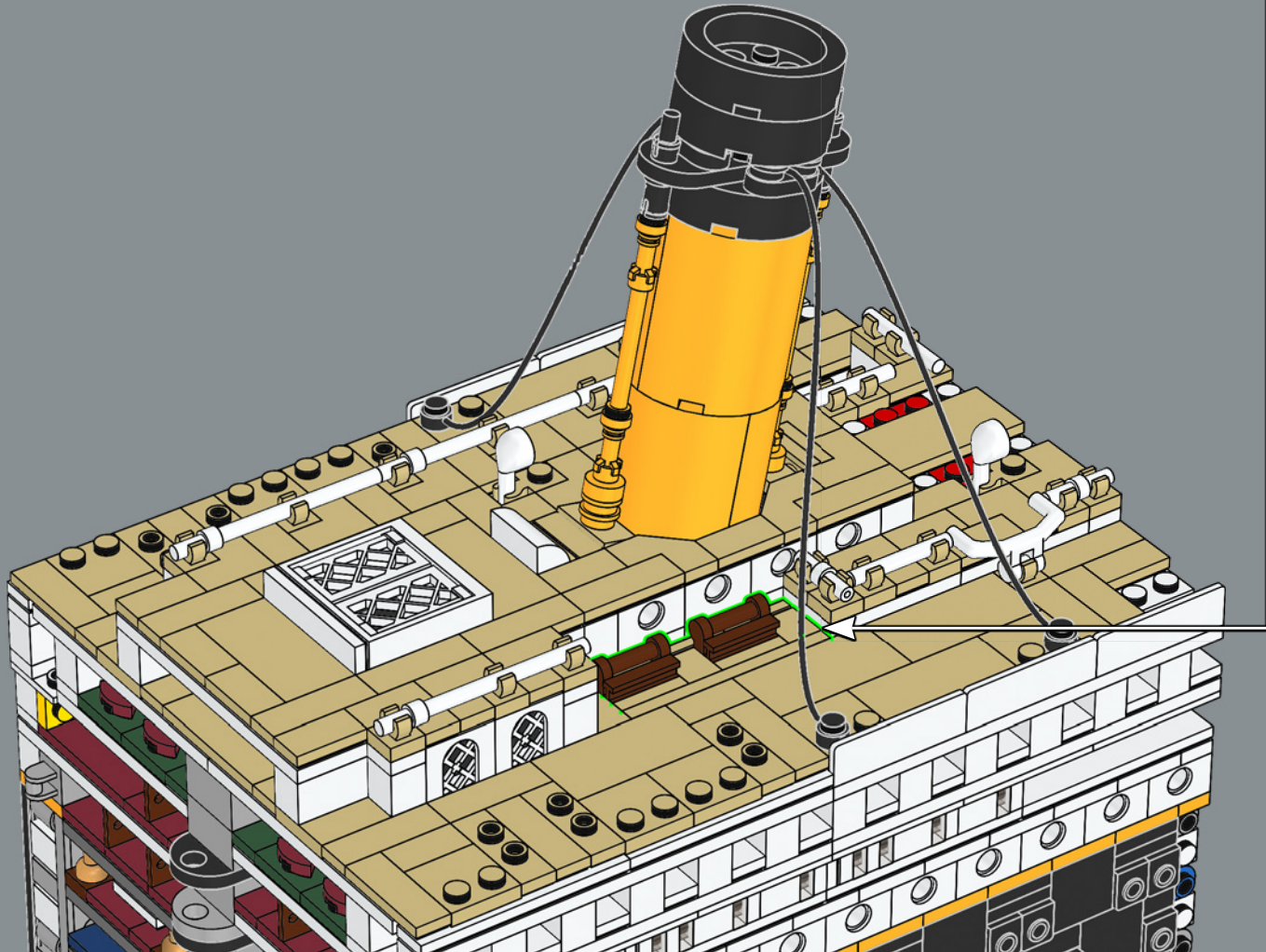
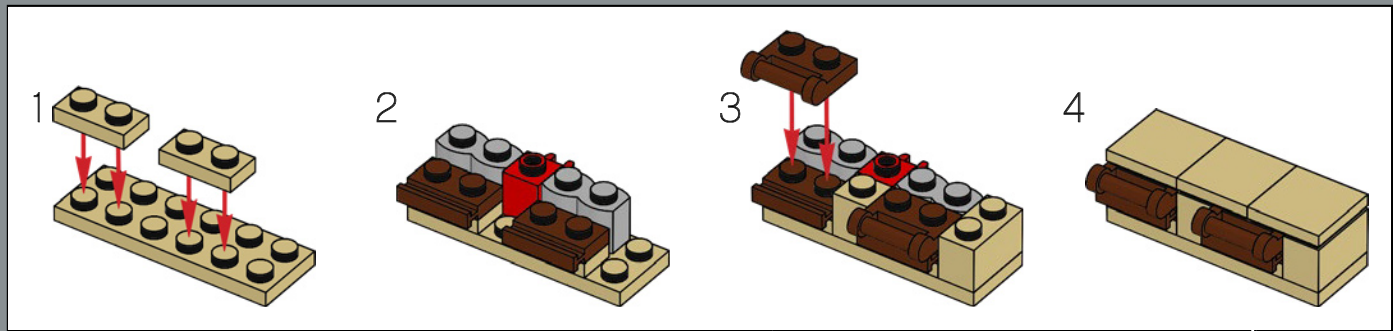

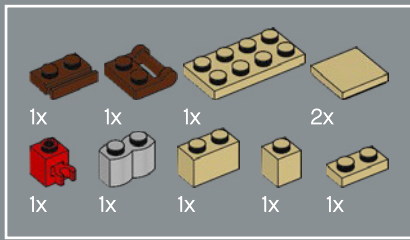

138

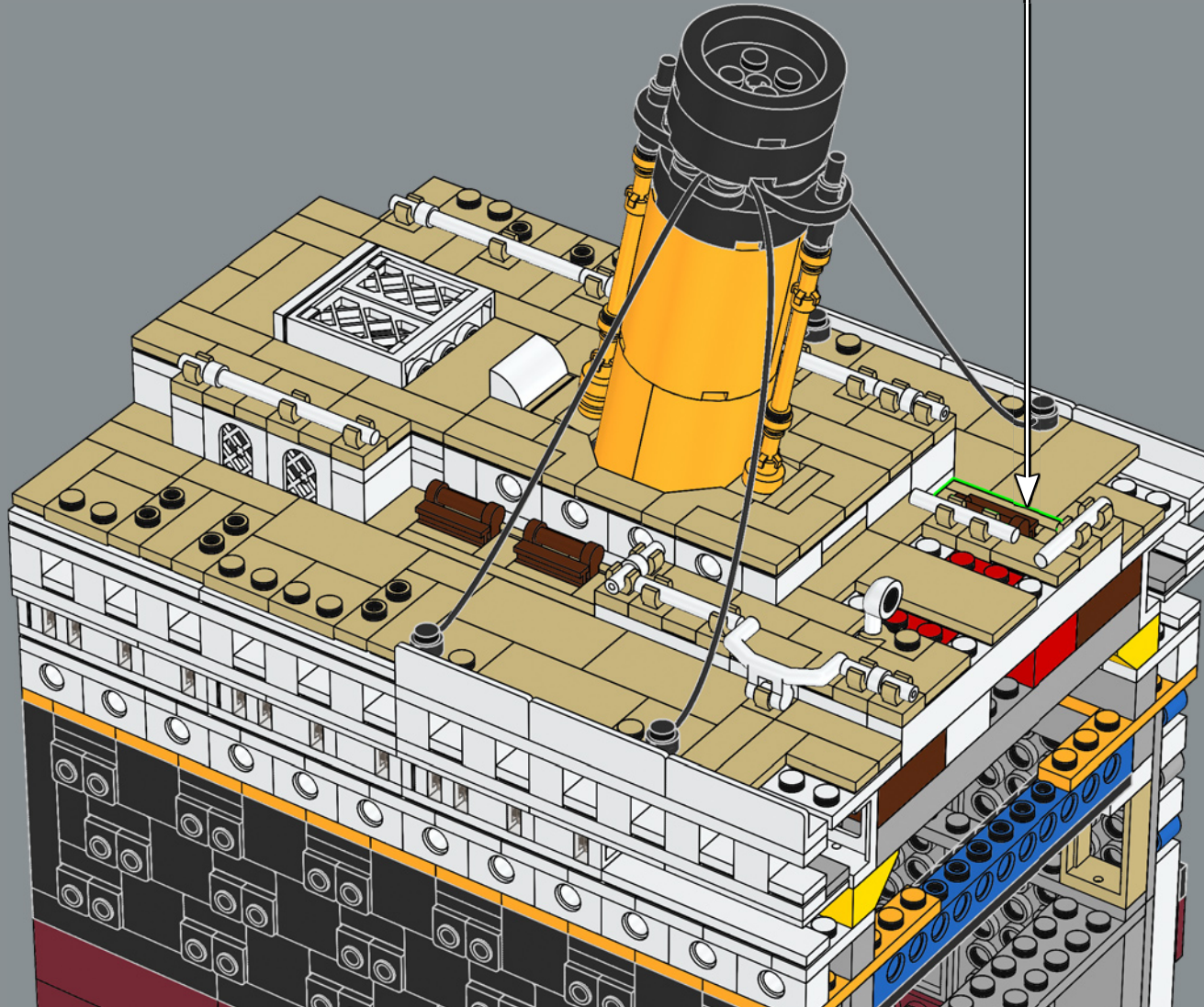
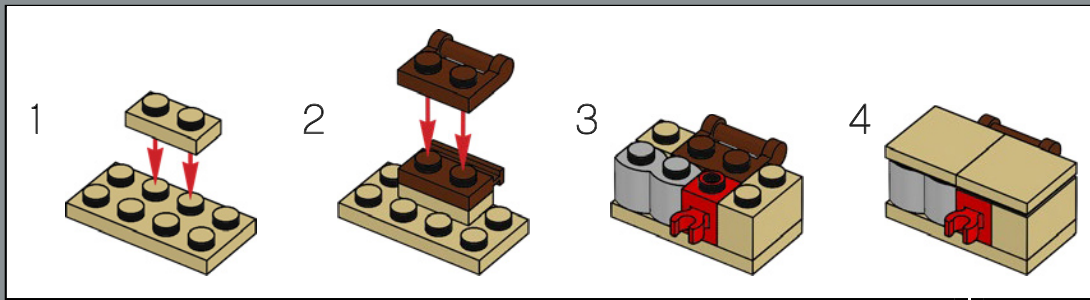

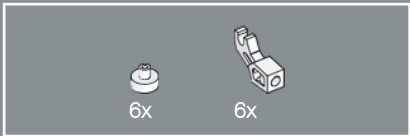

139

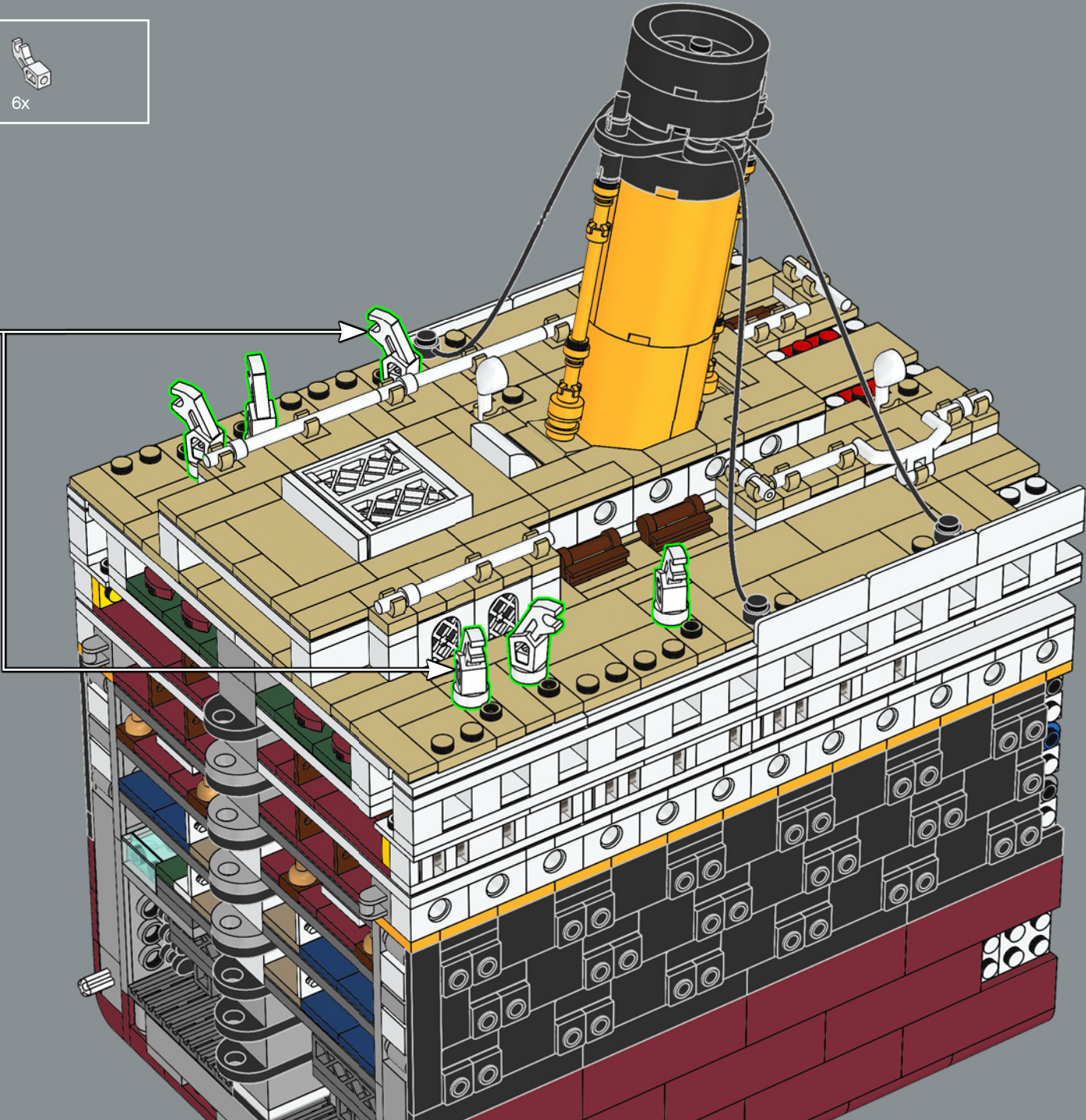
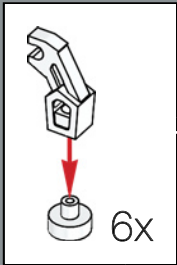

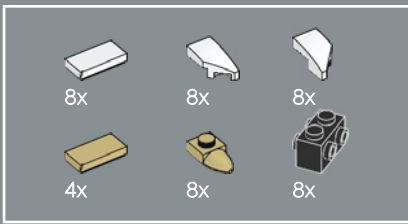

140

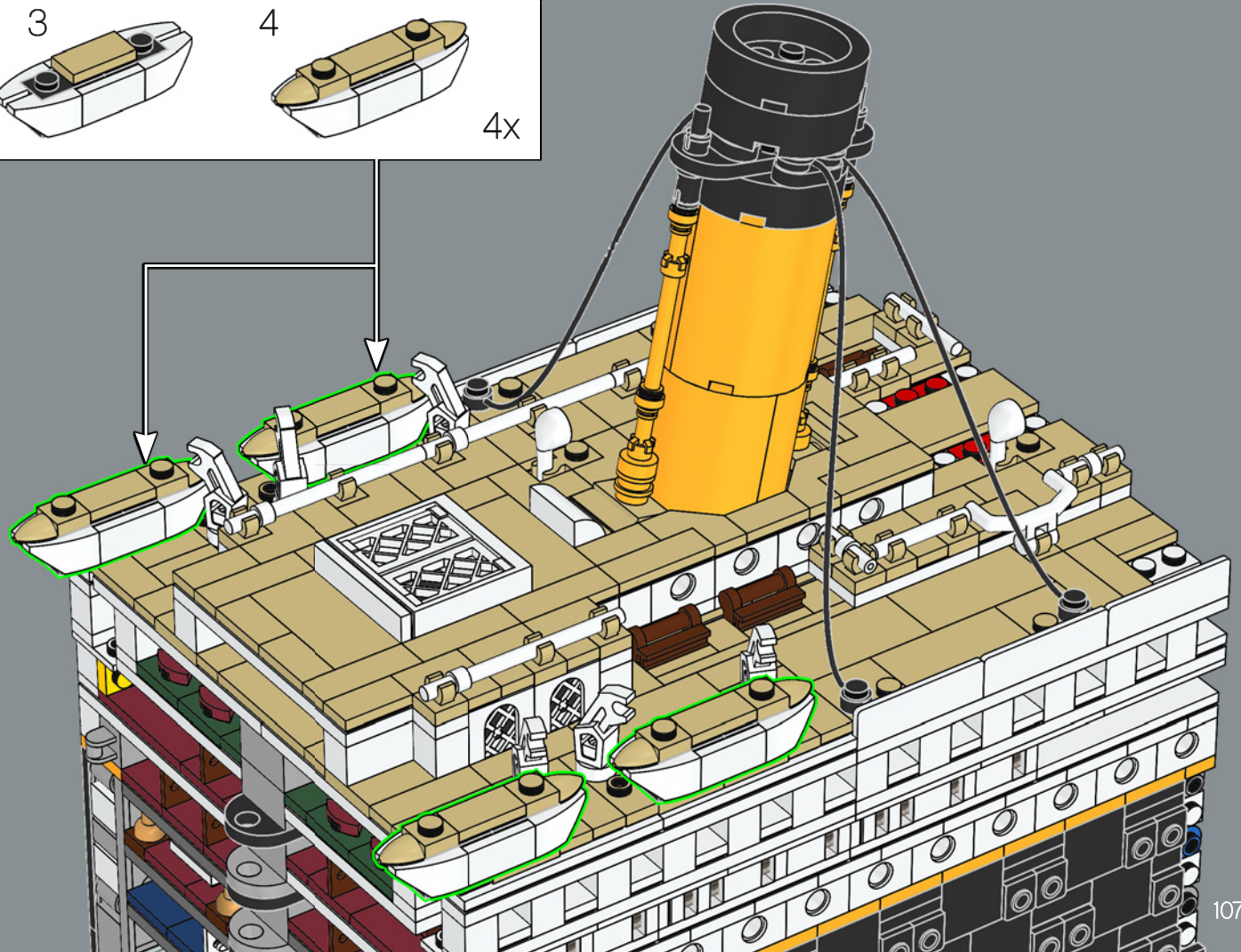
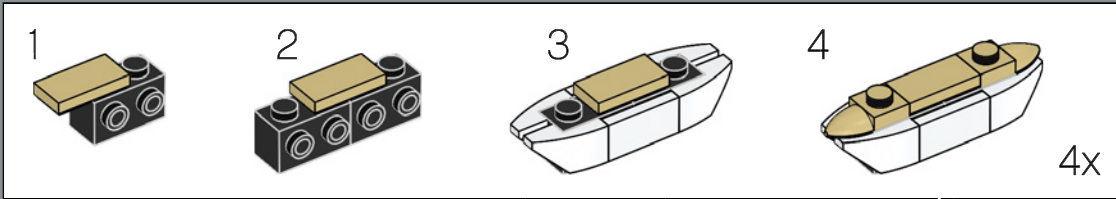

De los 20 botes salvavidas a bordo, 14 eran embarcaciones de madera convencionales, con capacidad para 65 personas cada una, y cuatro eran plegables, con capacidad para 47 personas.

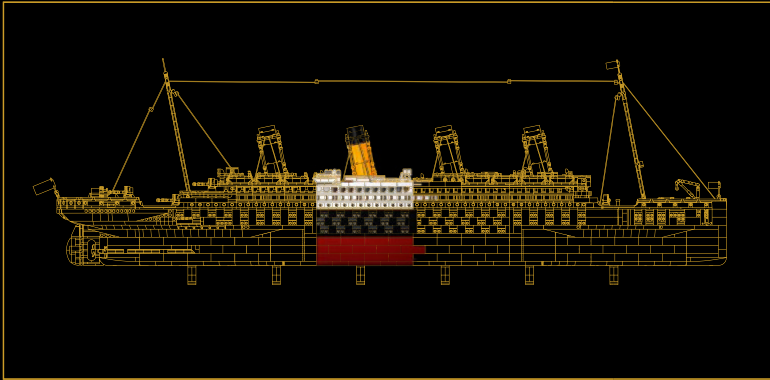

SECCIÓN 4:

CHIMENEA Y BRÚJULA

Esta sección incluye una porción de las enormes salas de máquinas del *Titanic* y la estructura elevada central donde se encontraba la brújula principal. Se instaló en altura a fin de garantizar su buen funcionamiento con el mínimo de interferencias de la cantidad descomunal de hierro del casco del buque. Contiene también un pequeño modelo secundario que representa un banco usado por los pasajeros que disfrutaban de acceso a las cubiertas superiores del barco.



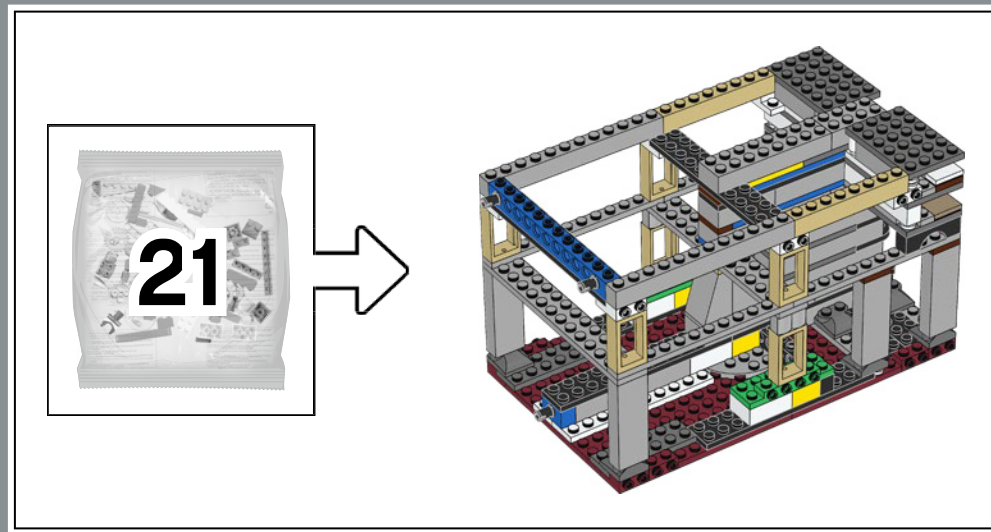

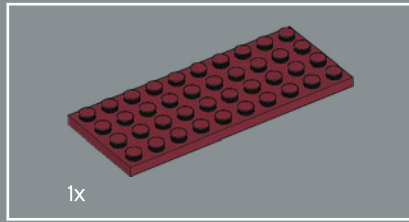
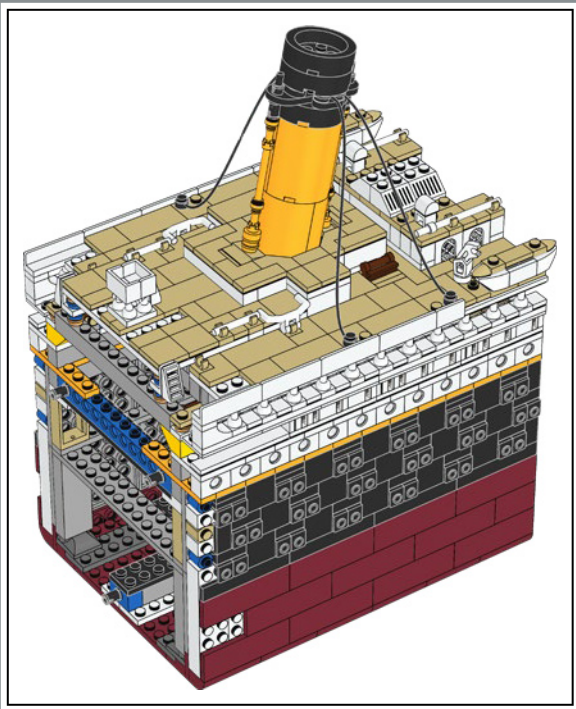

141

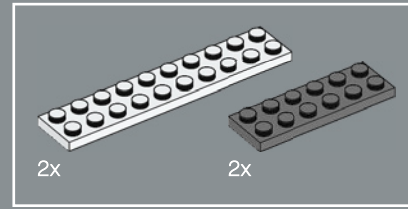
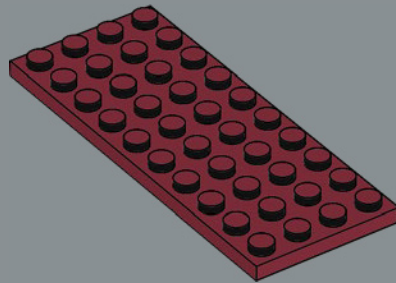

142

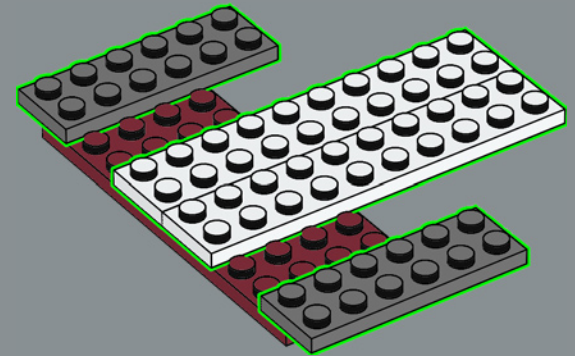

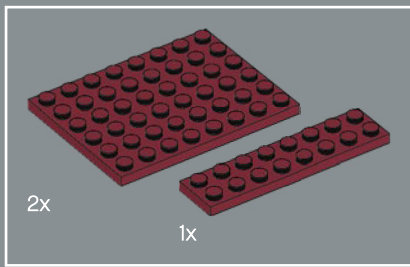

143

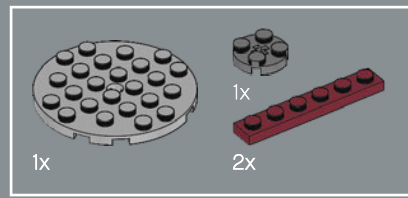
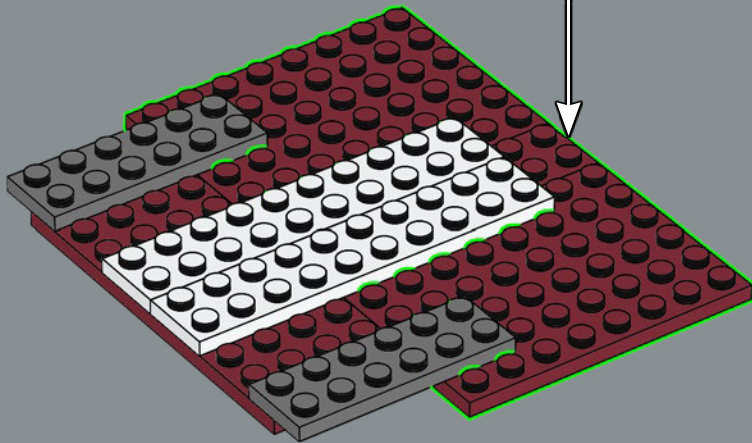
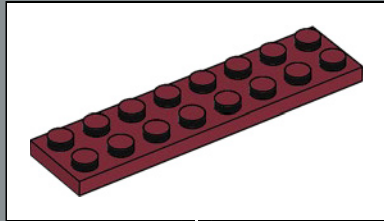

144

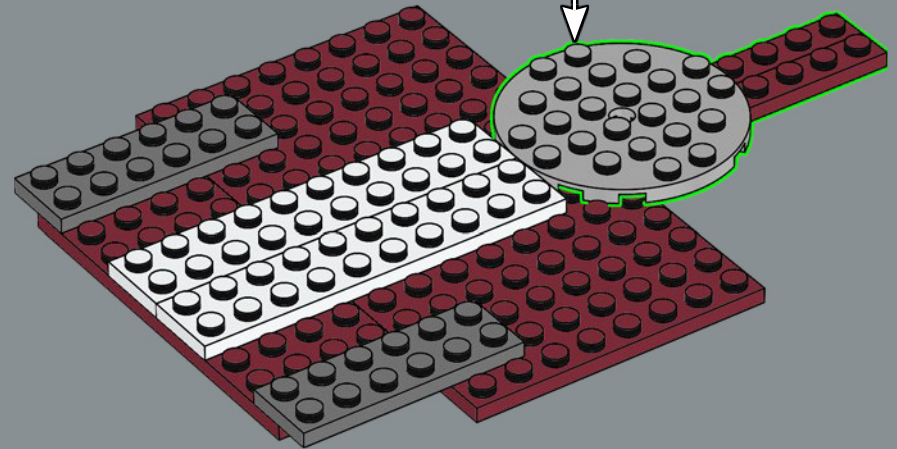
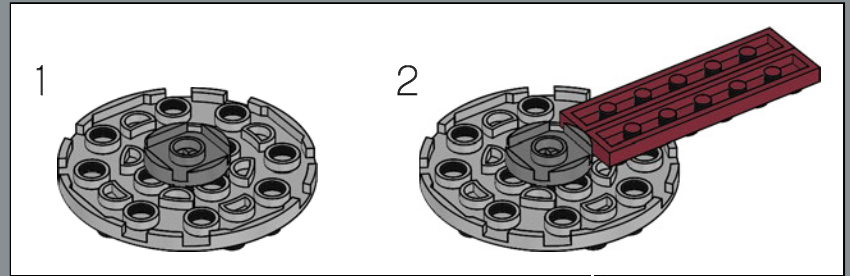

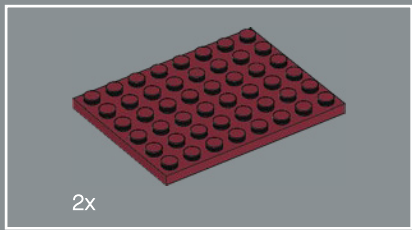

2x

145

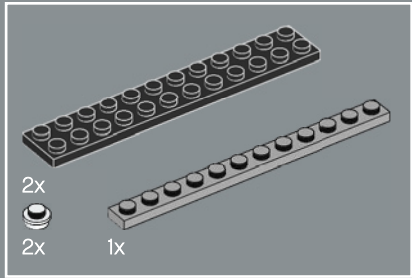
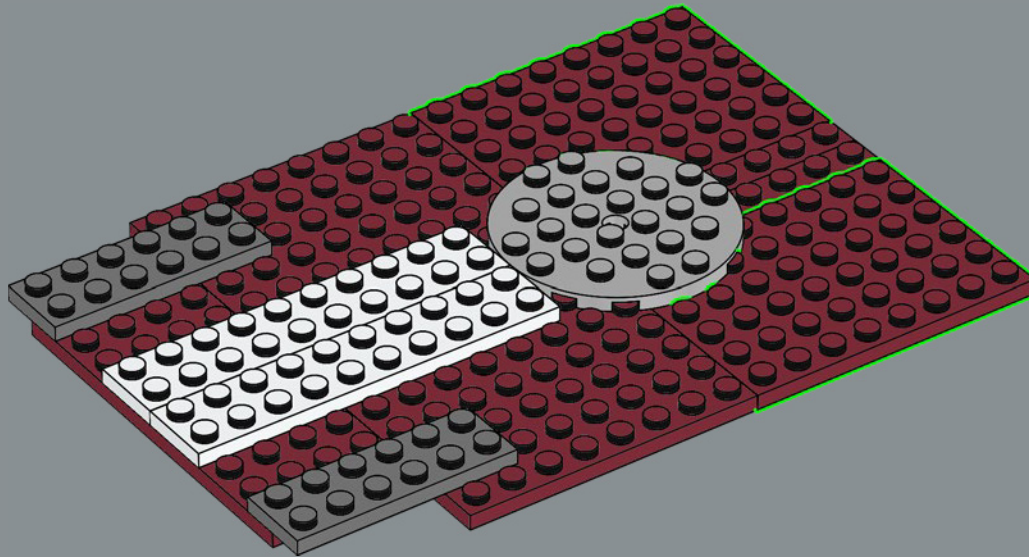

2x



2x

1x

146

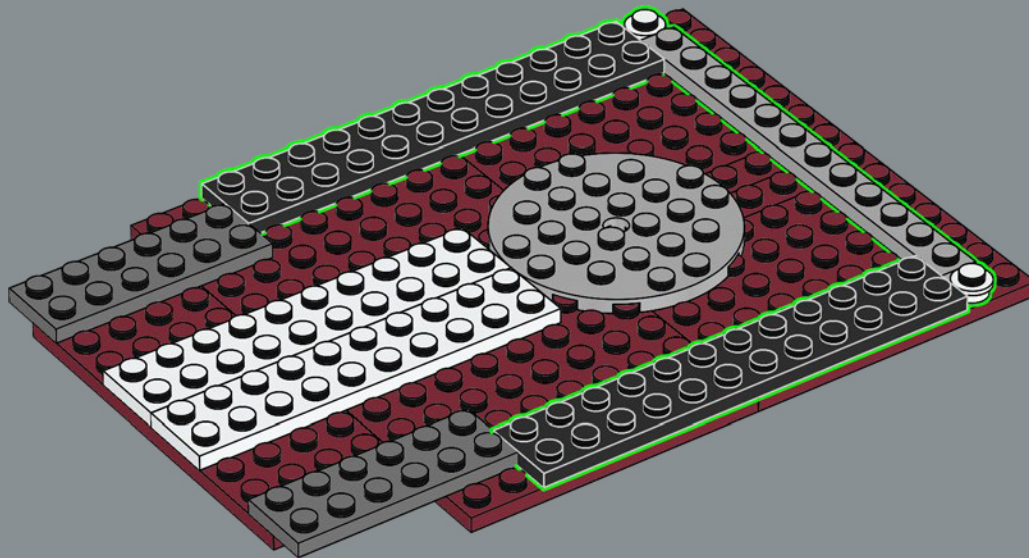

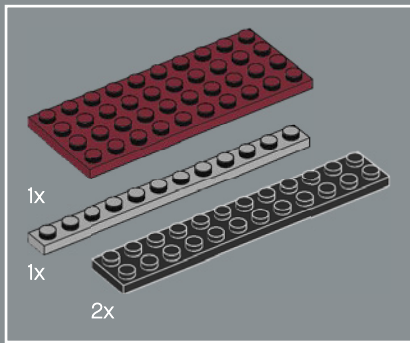

147

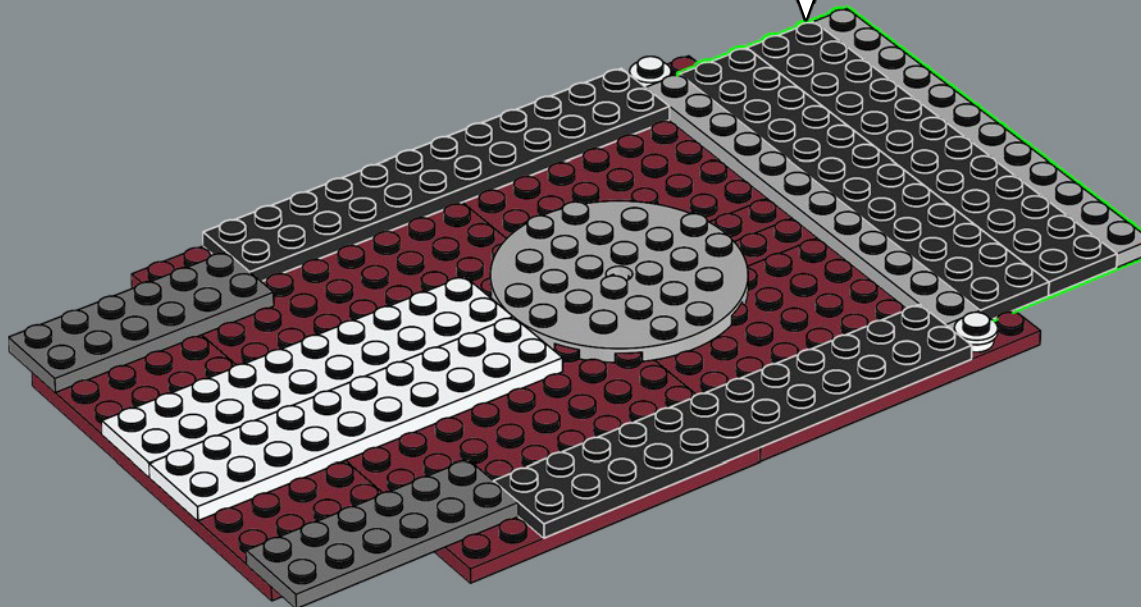
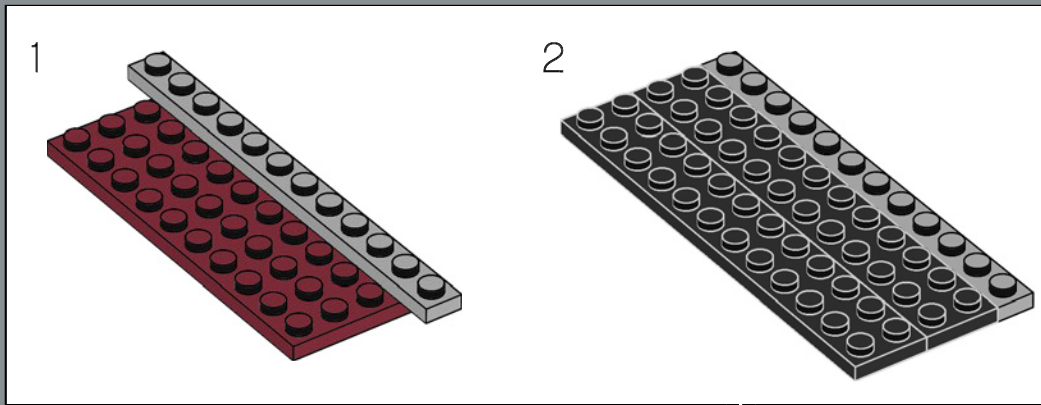



148

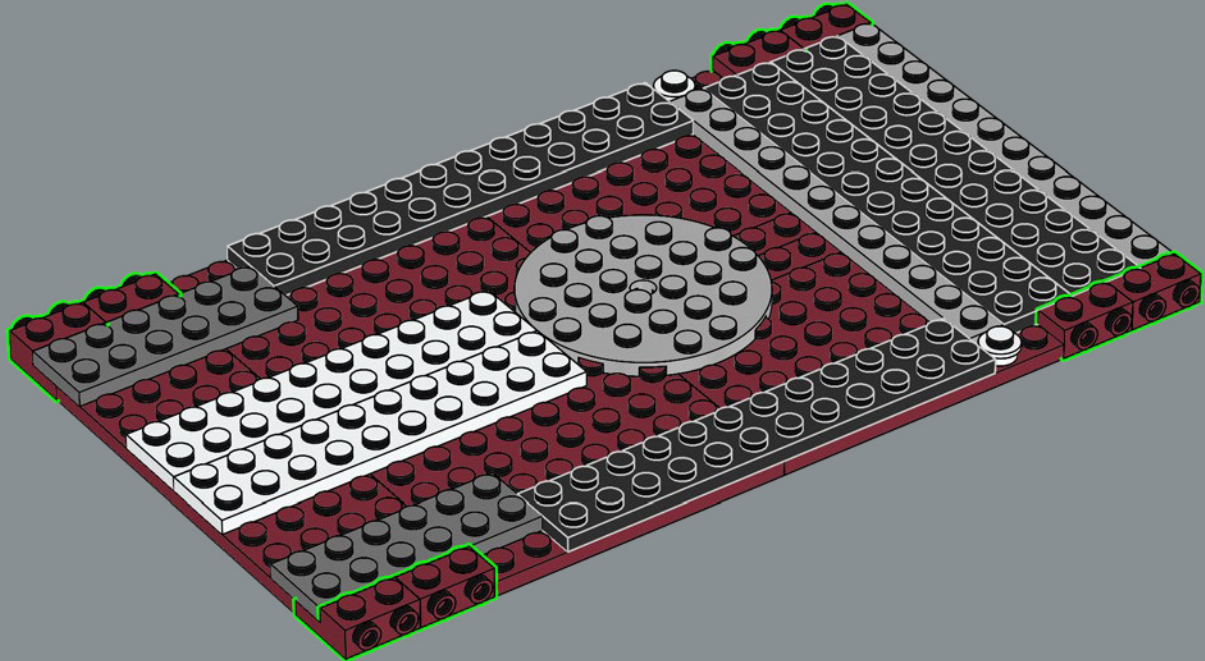

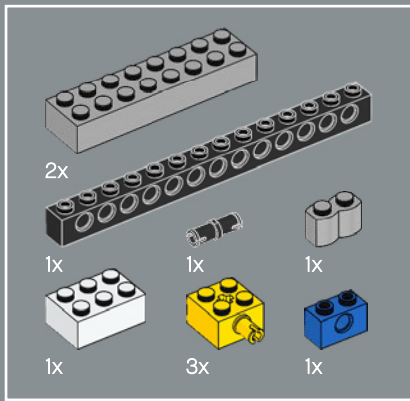

149

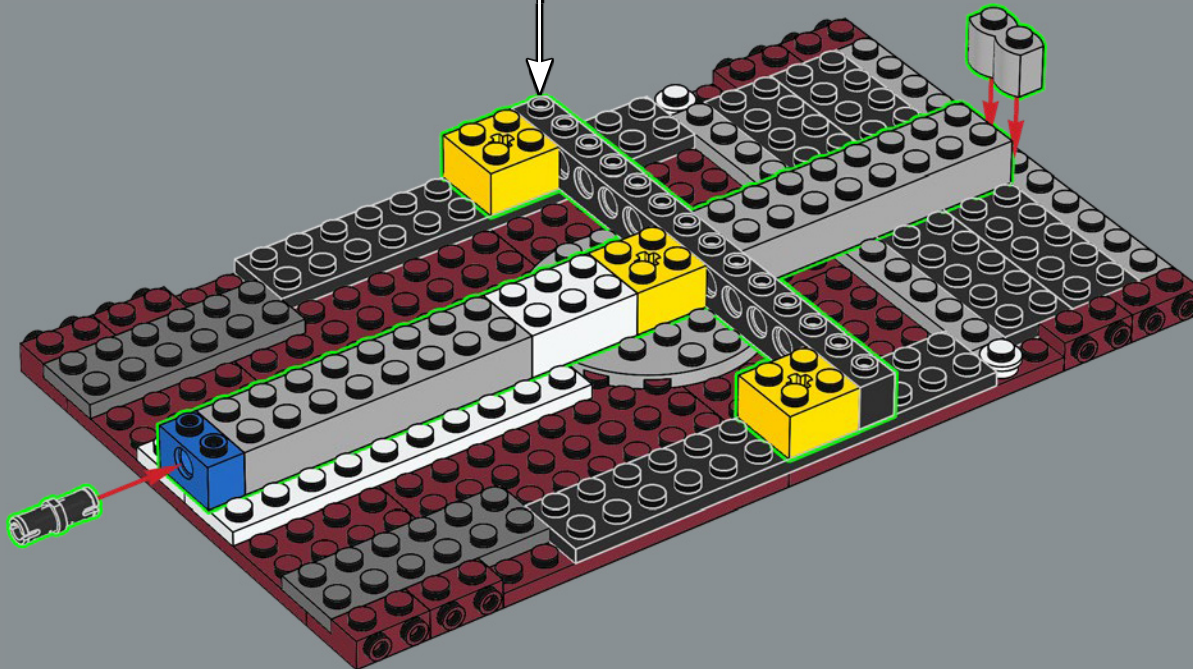
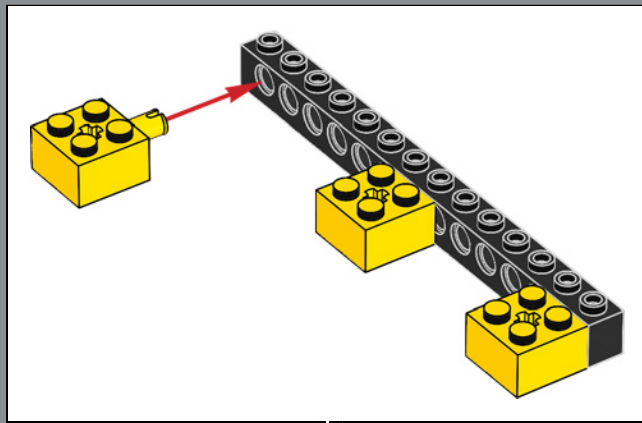

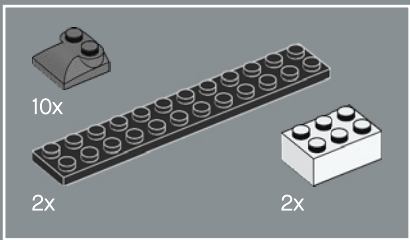

150

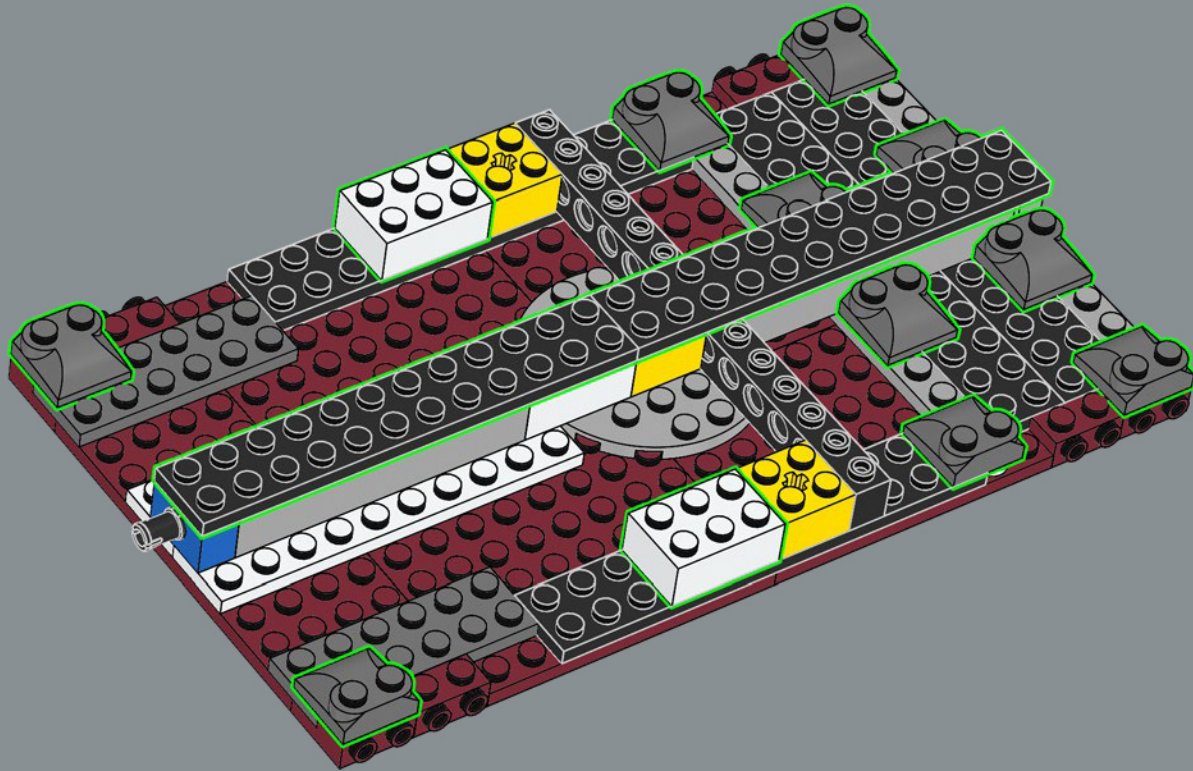

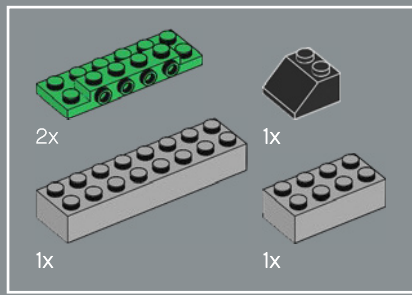

151

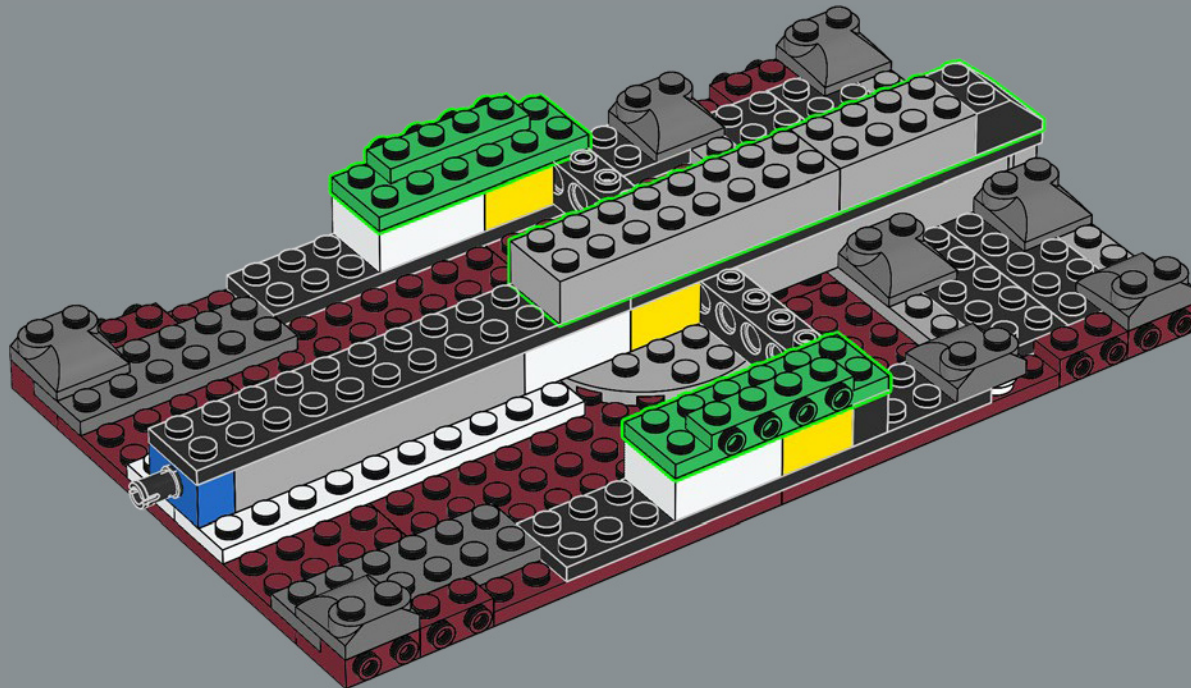

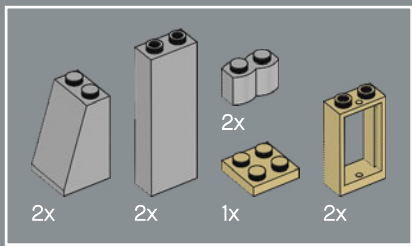

152

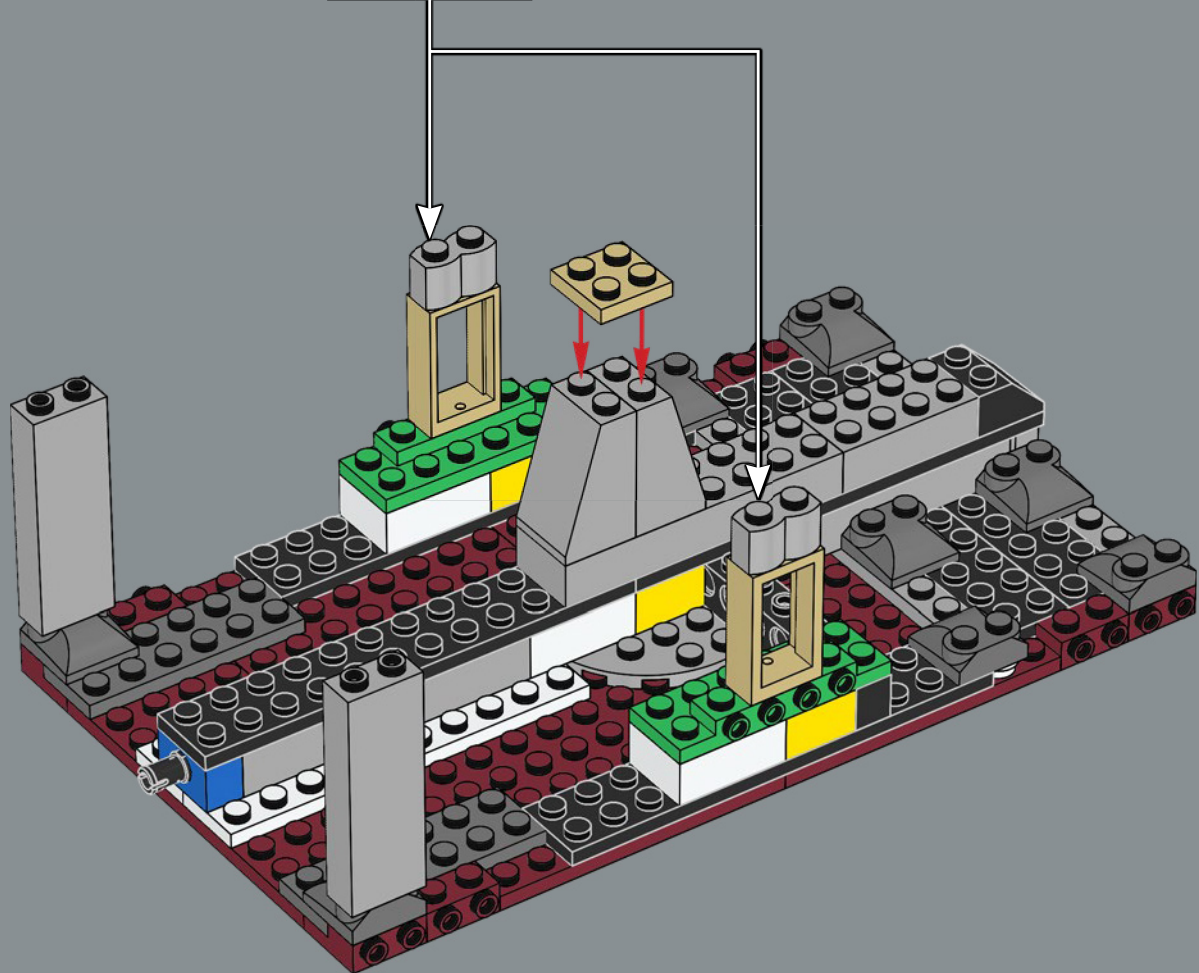
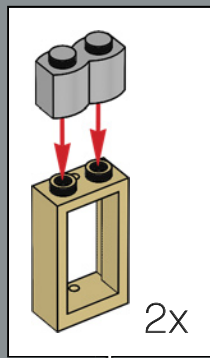

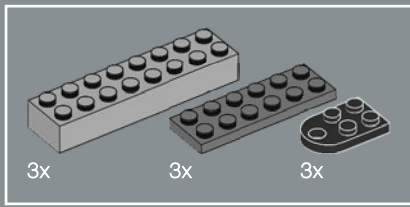

153

1

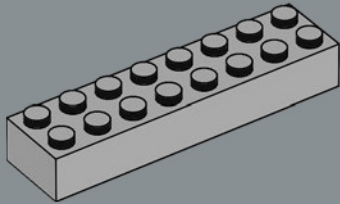

2

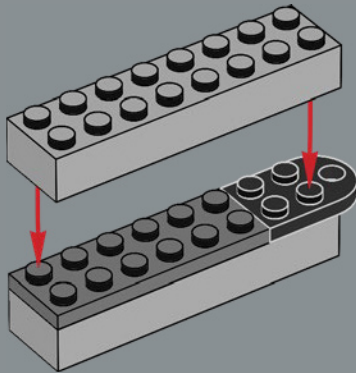

3

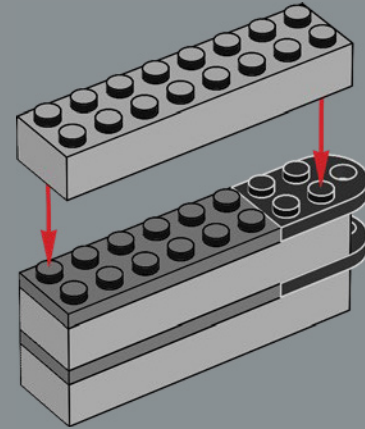

4

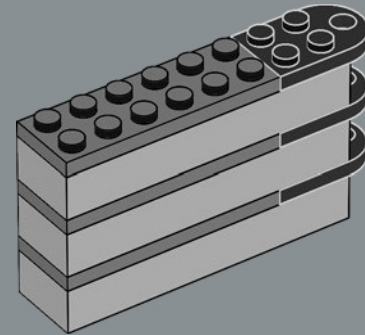

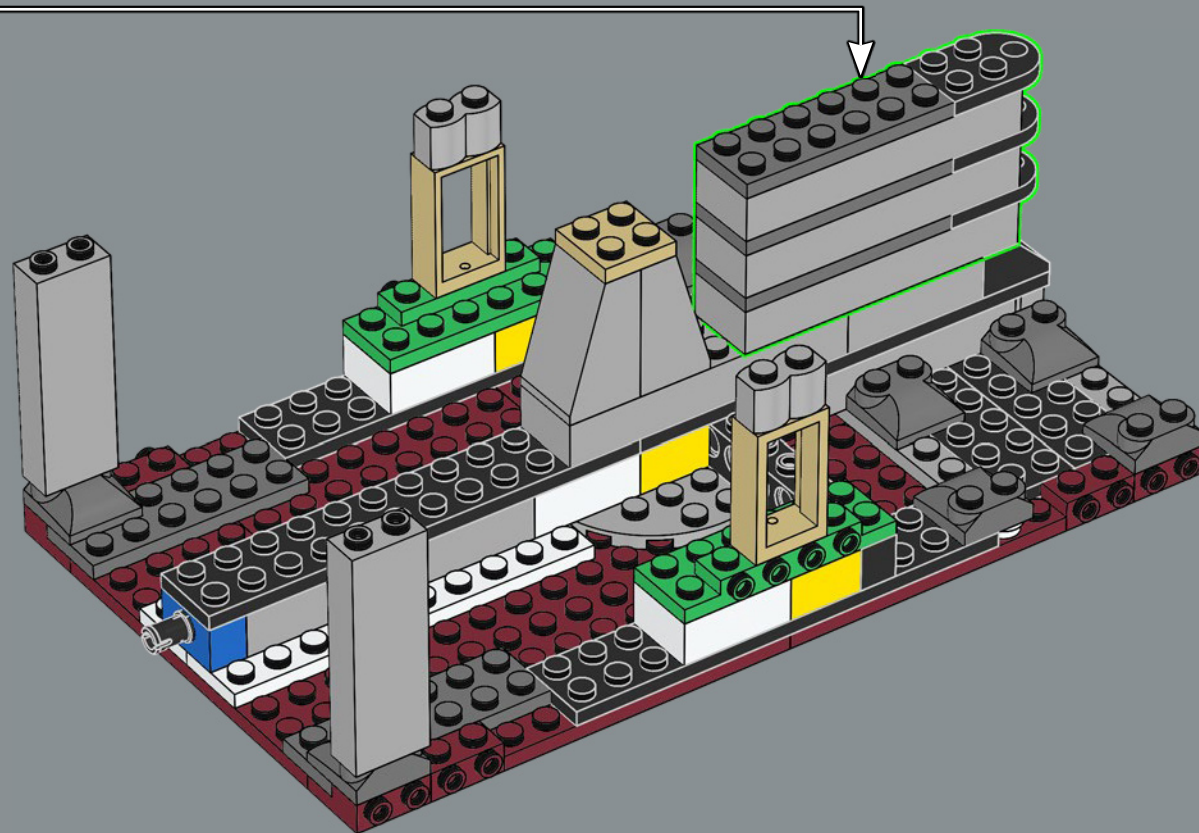

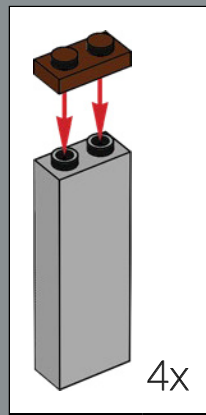
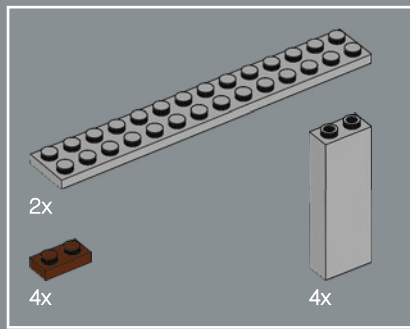

154

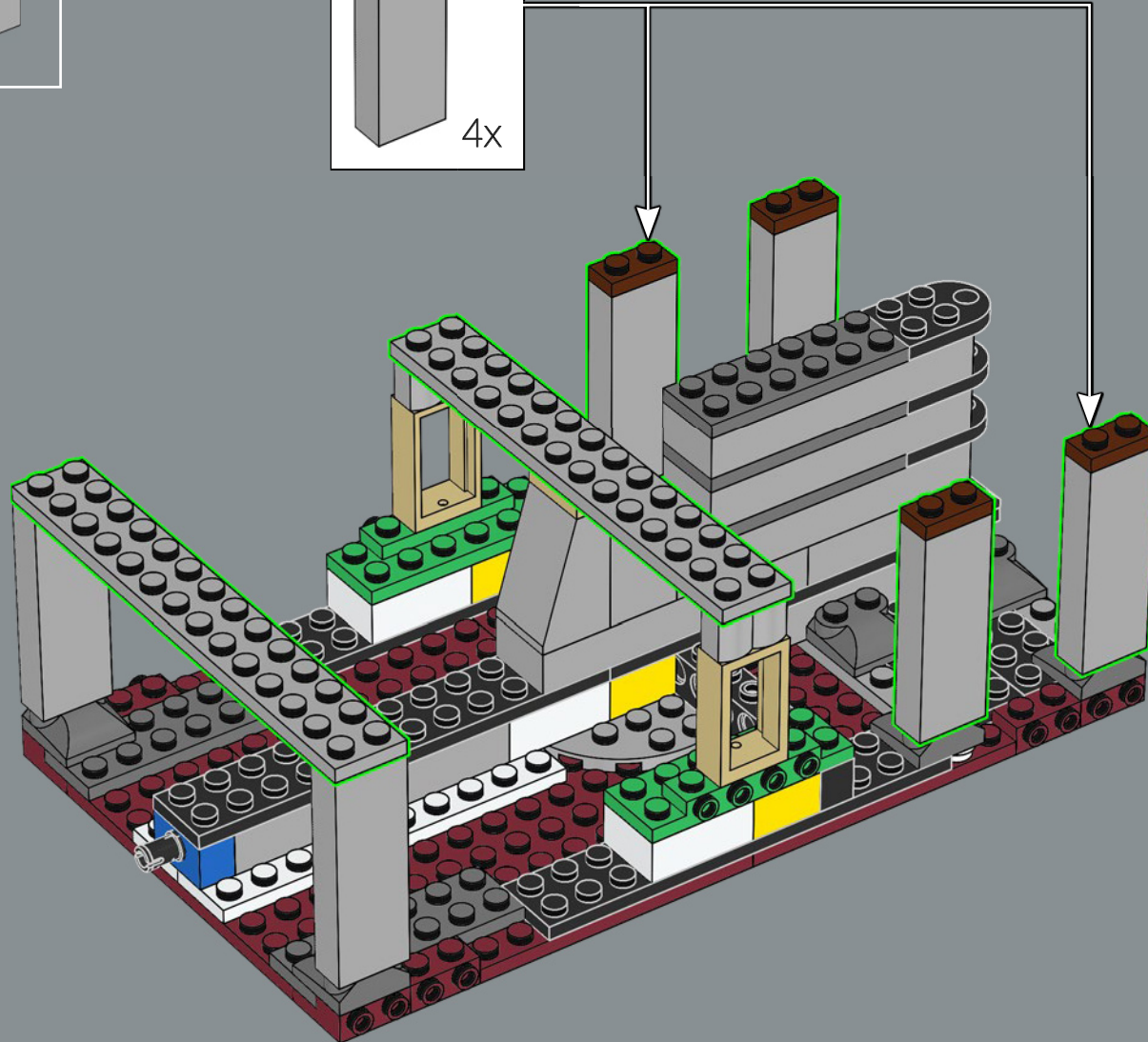

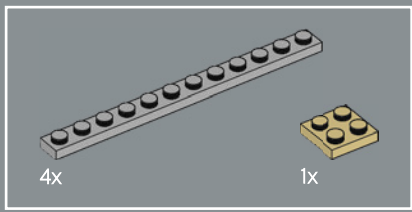

155

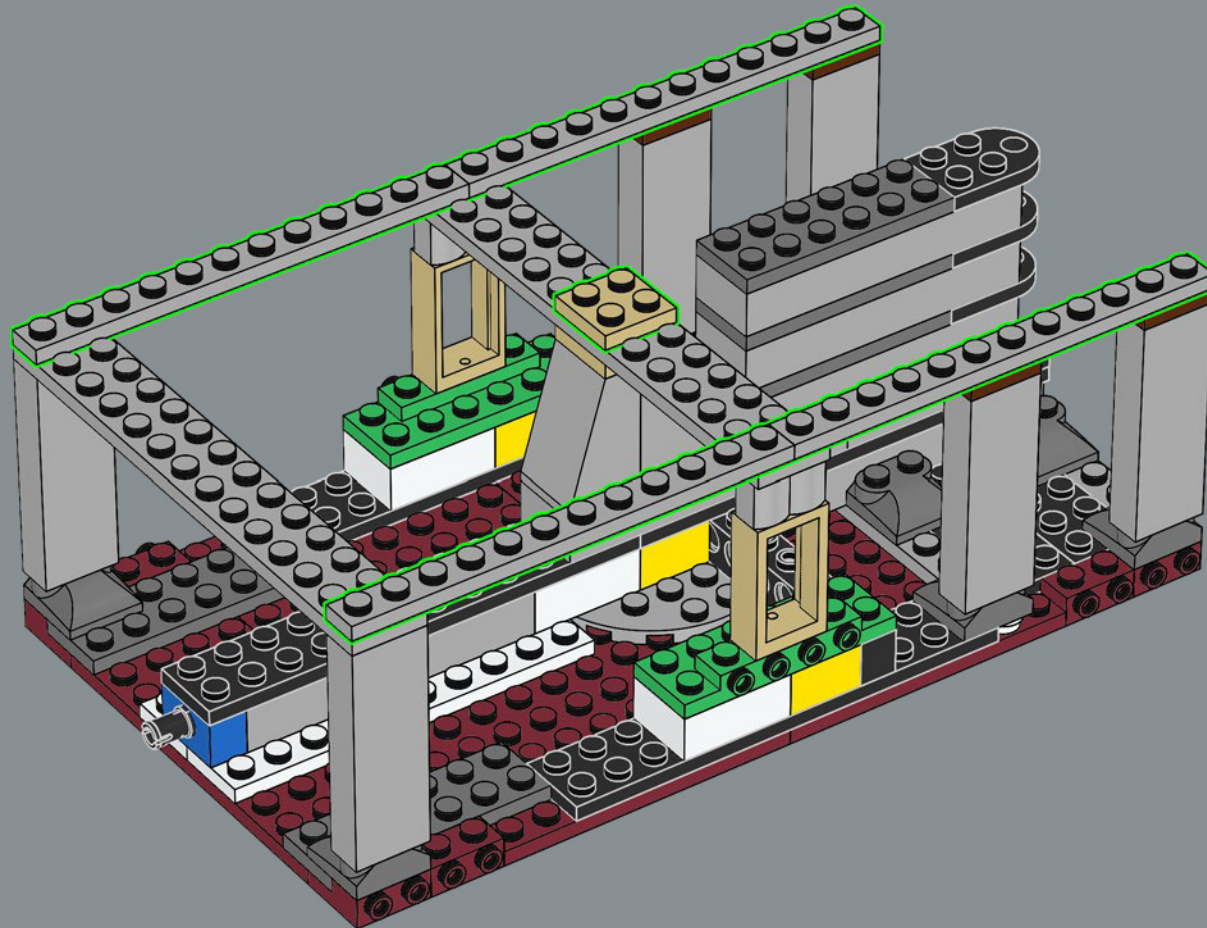

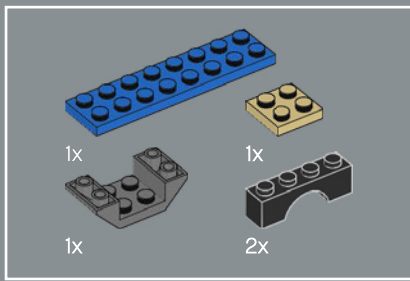

156

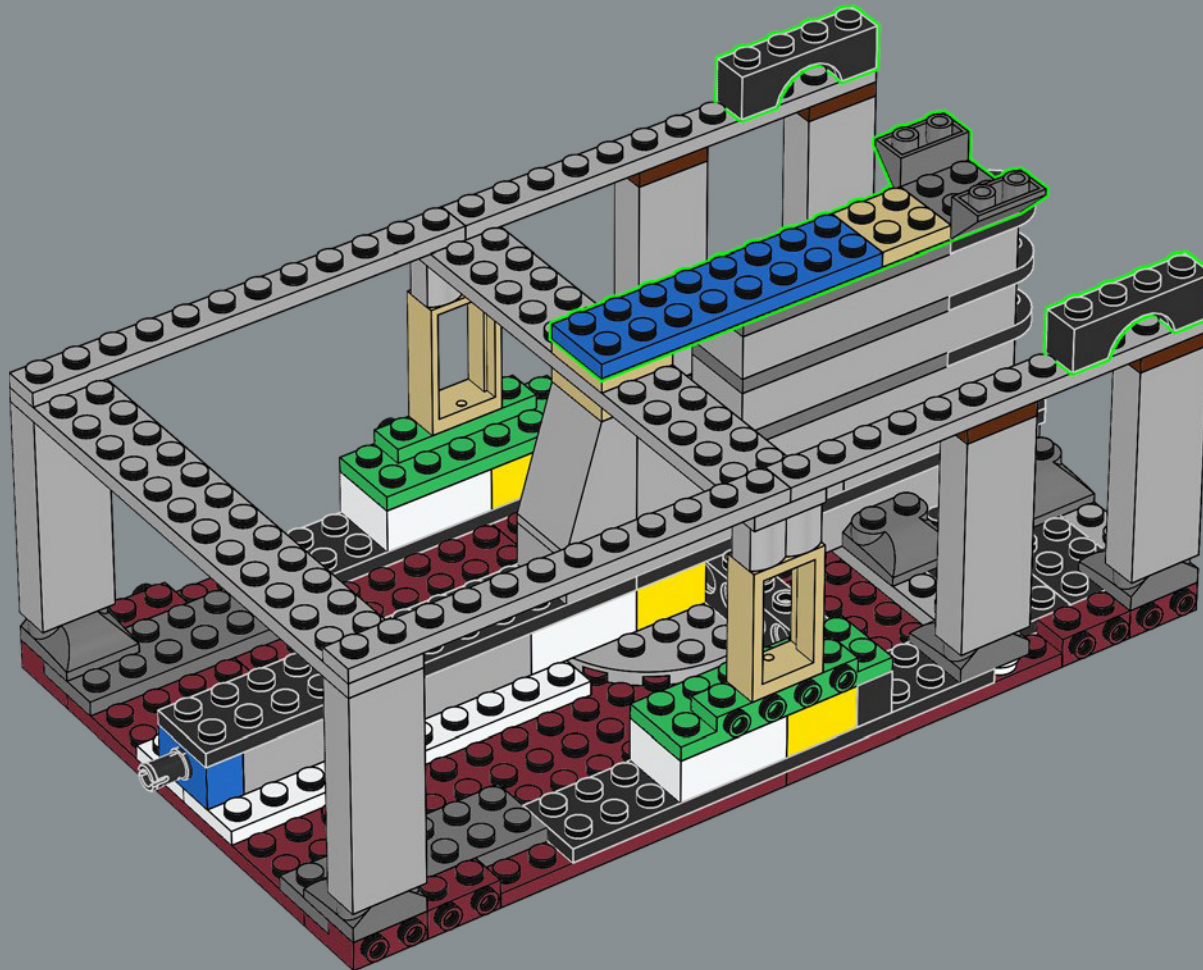

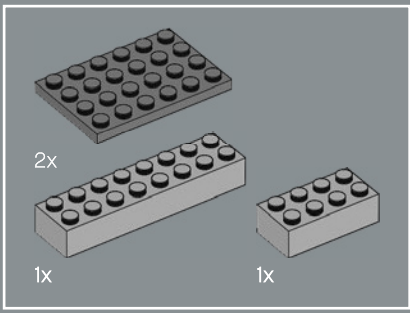

157

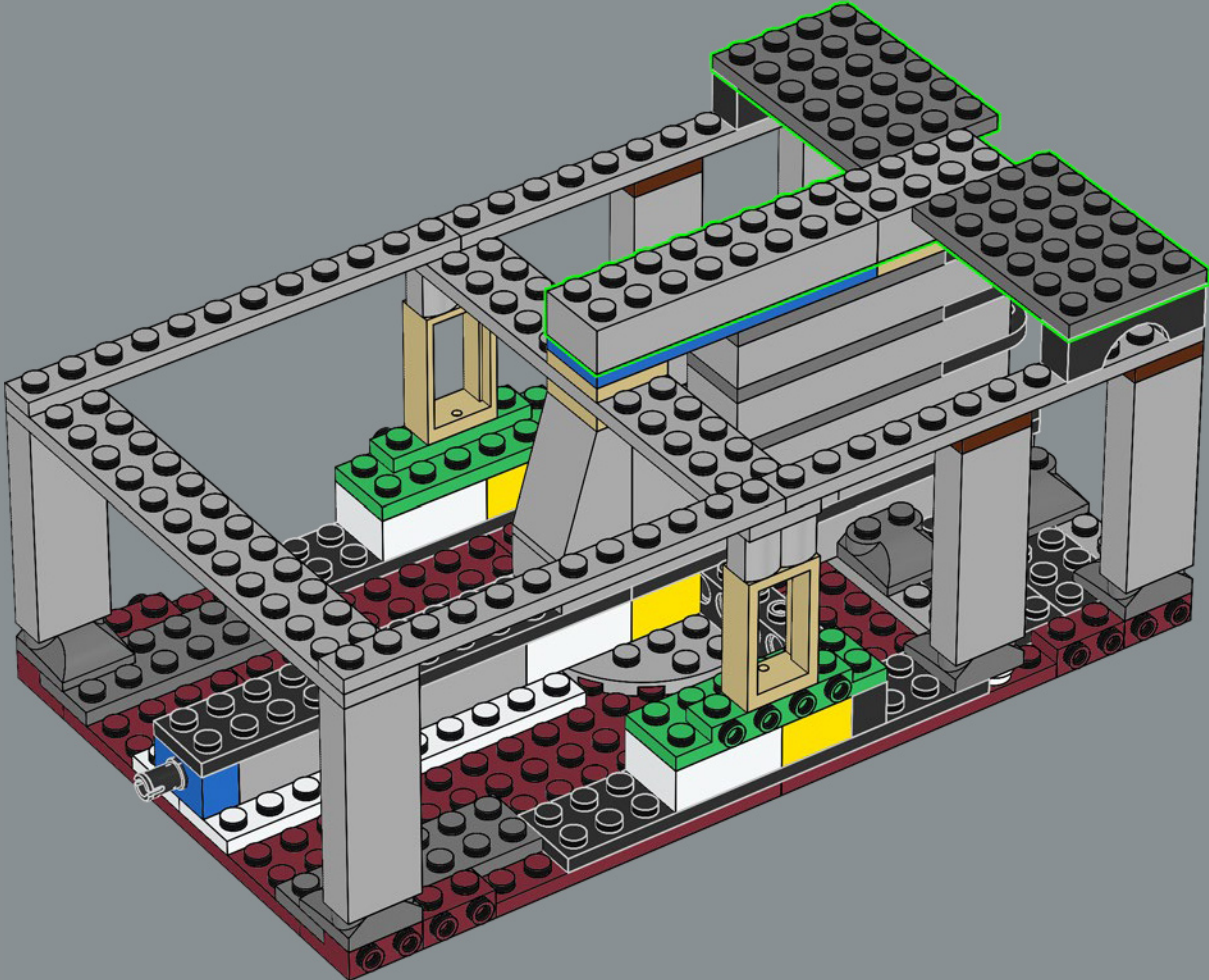

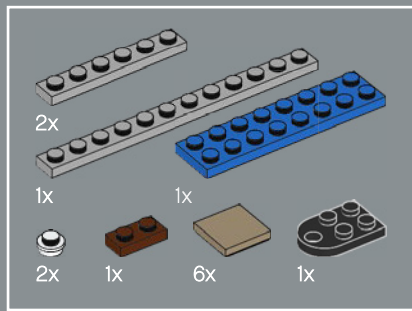

158

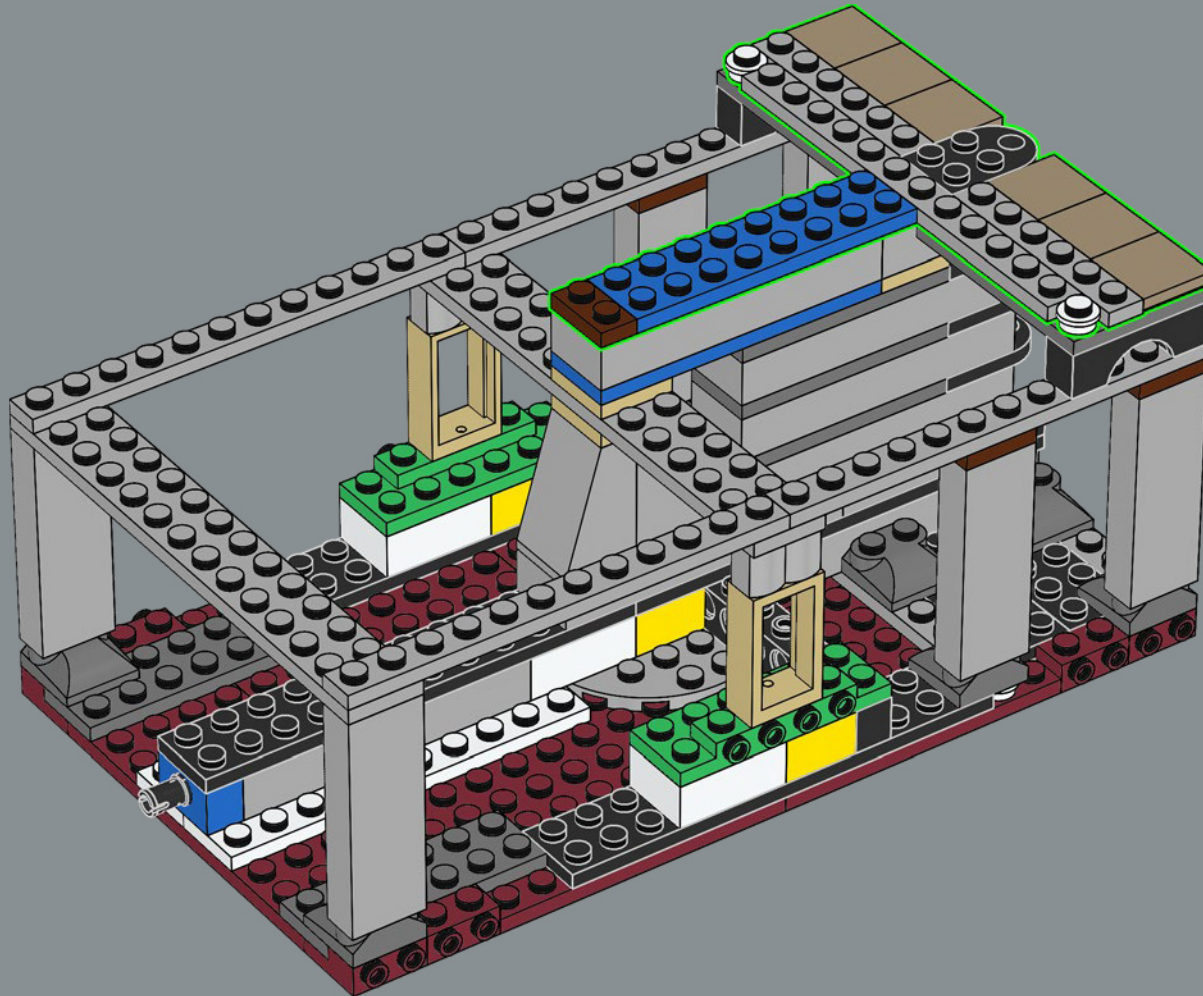

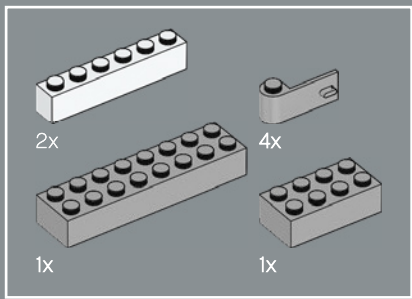

159

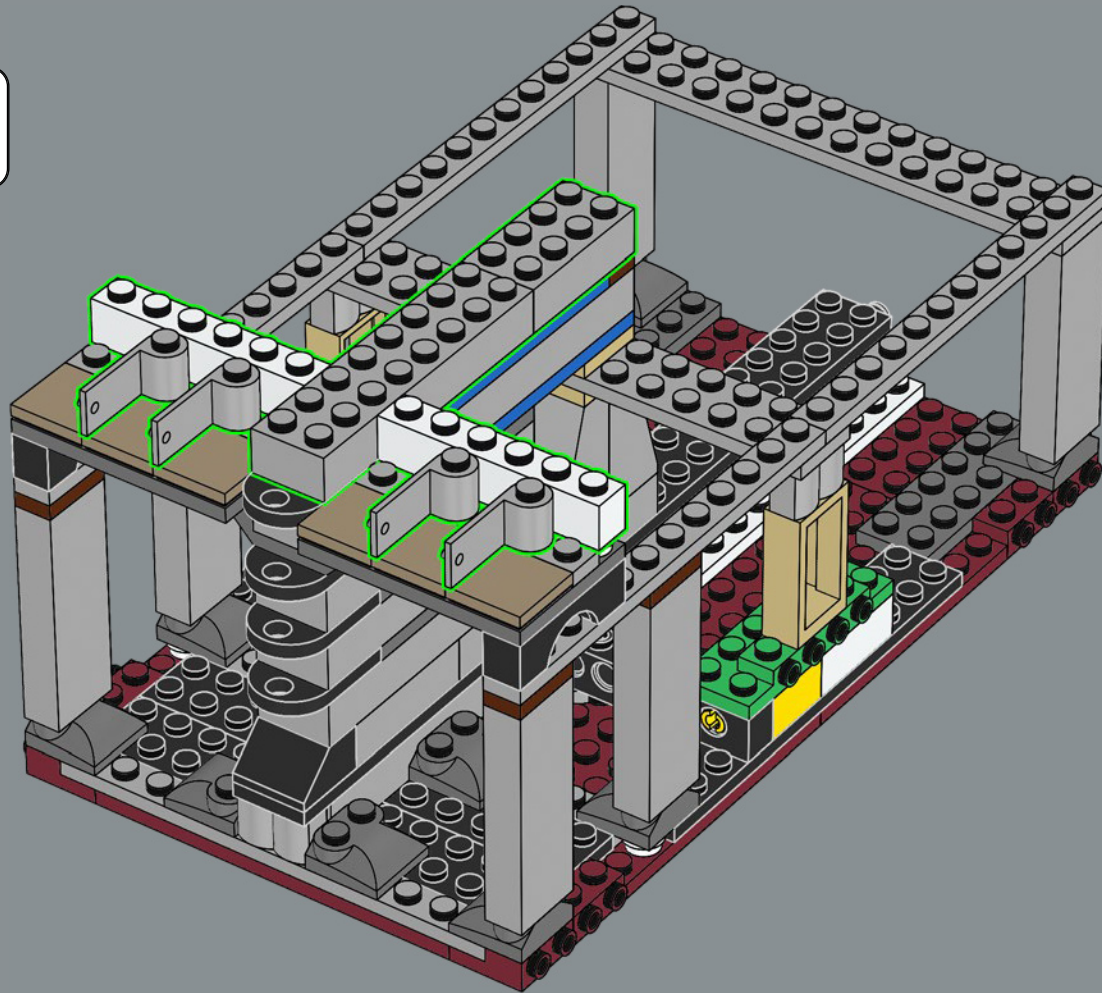

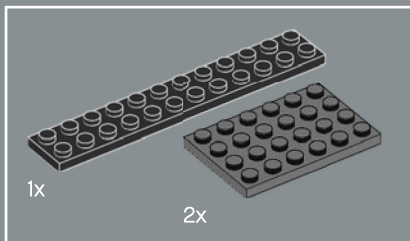

160

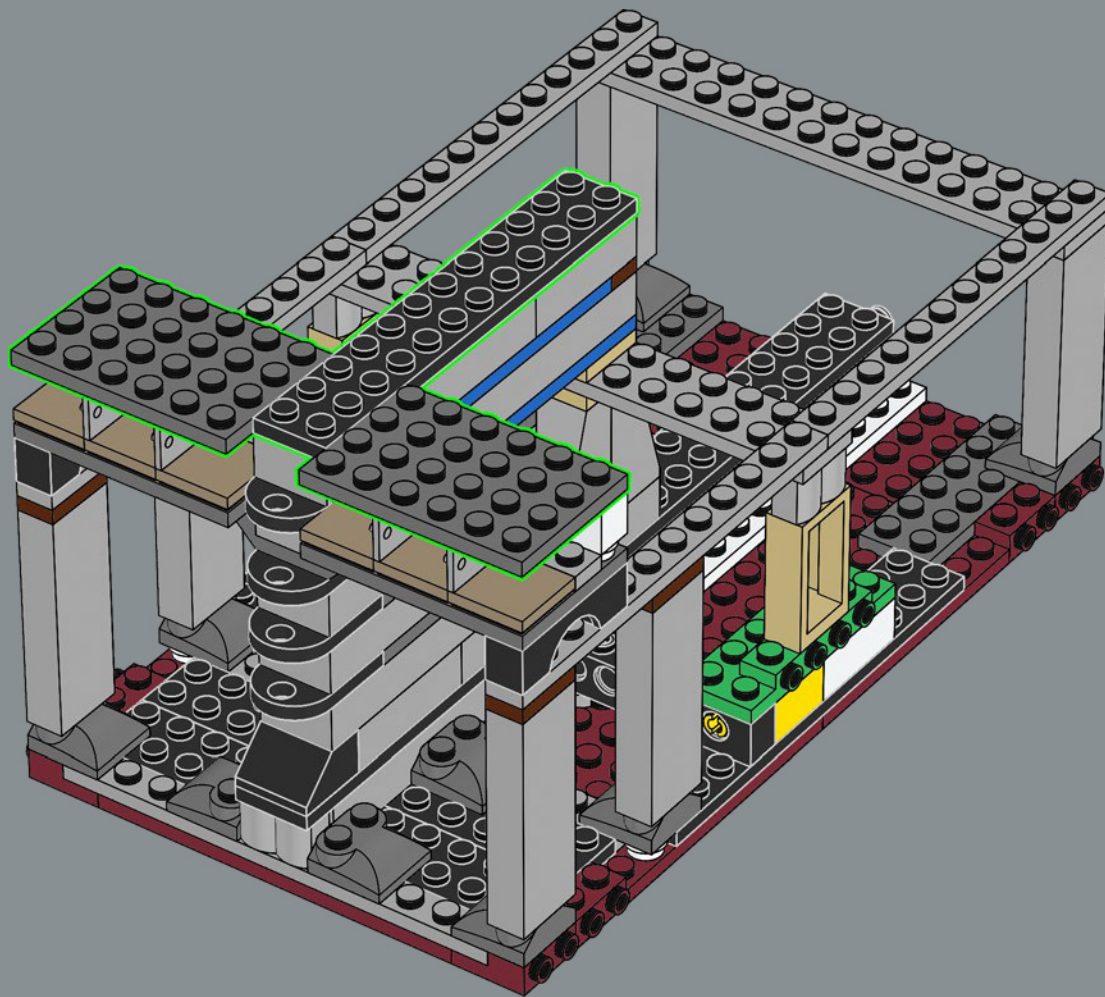

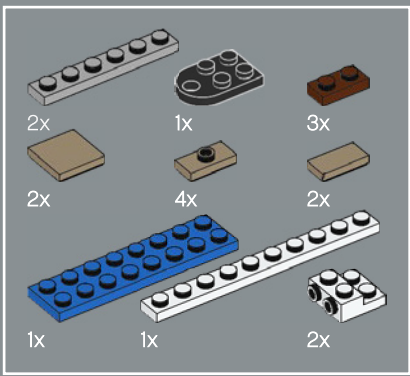

161

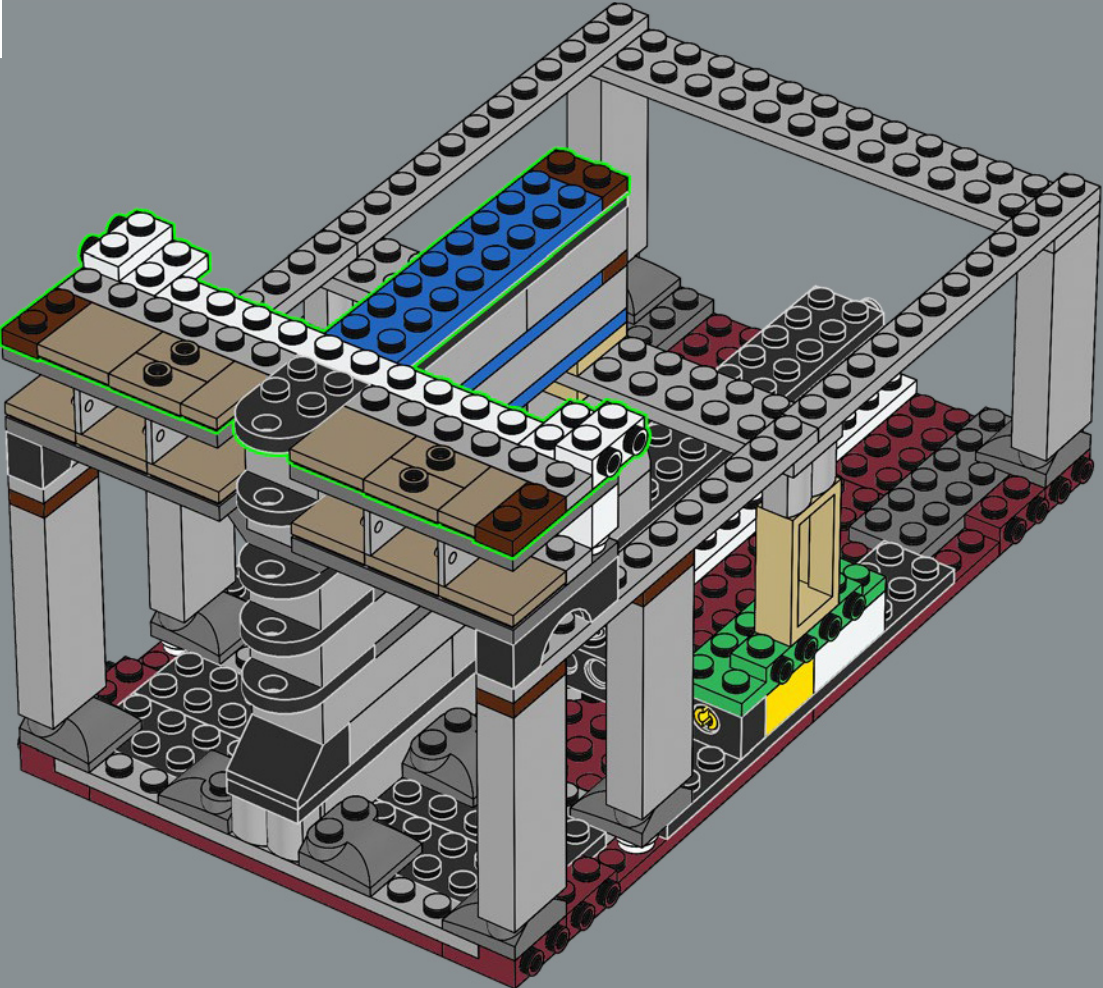

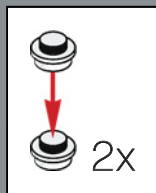
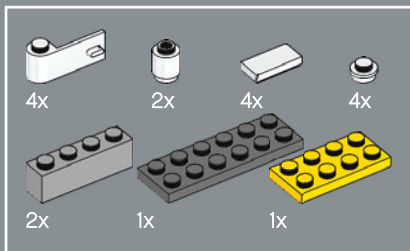

162

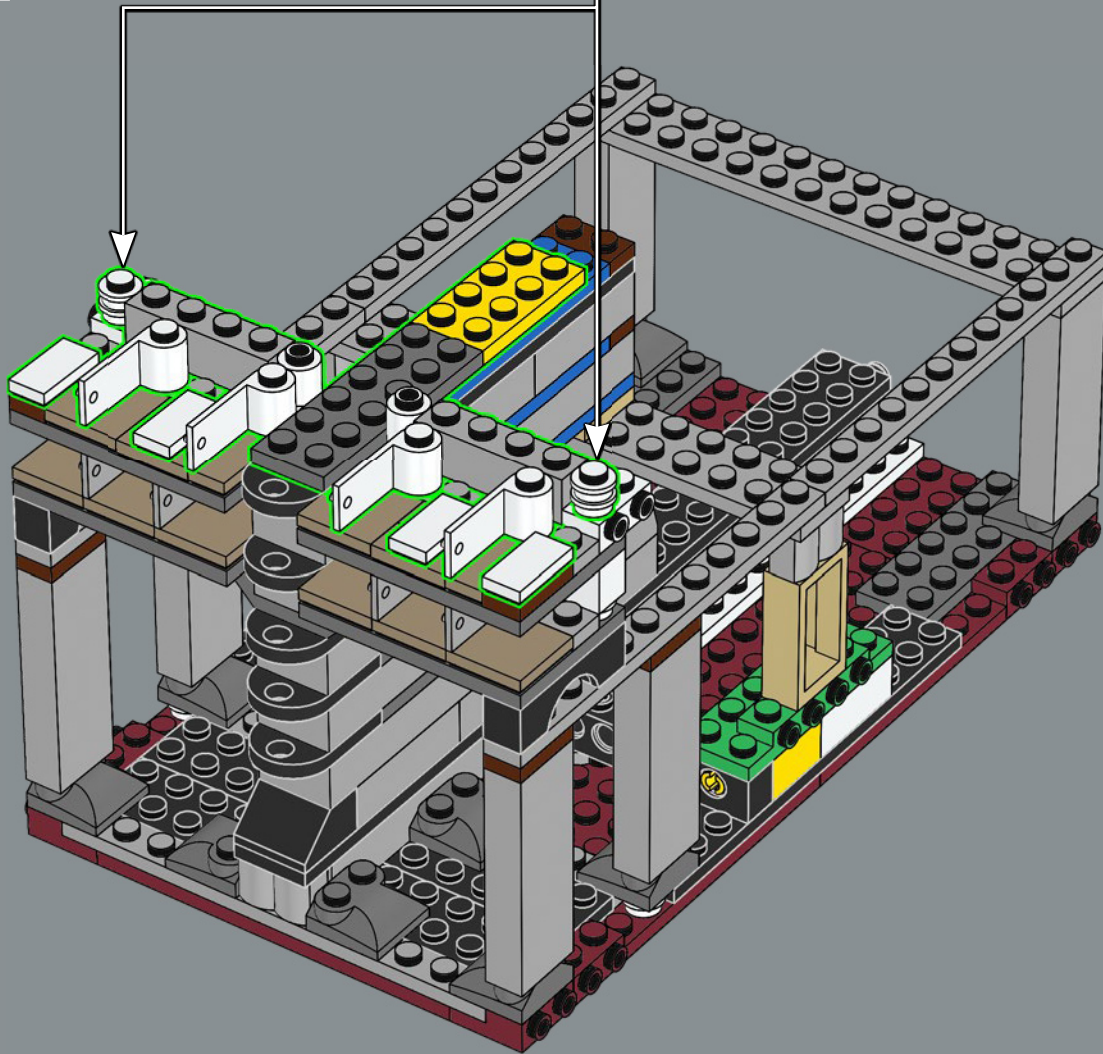

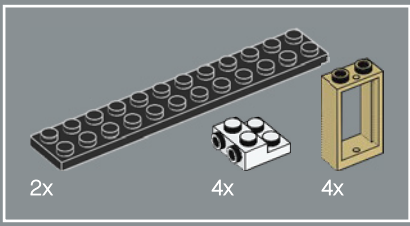

163

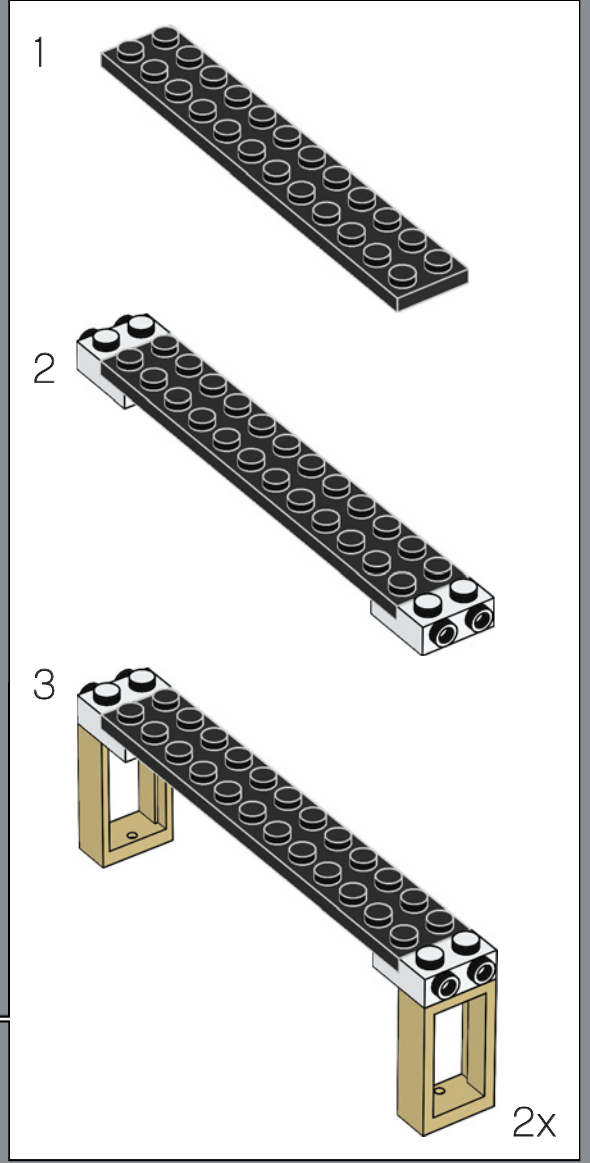
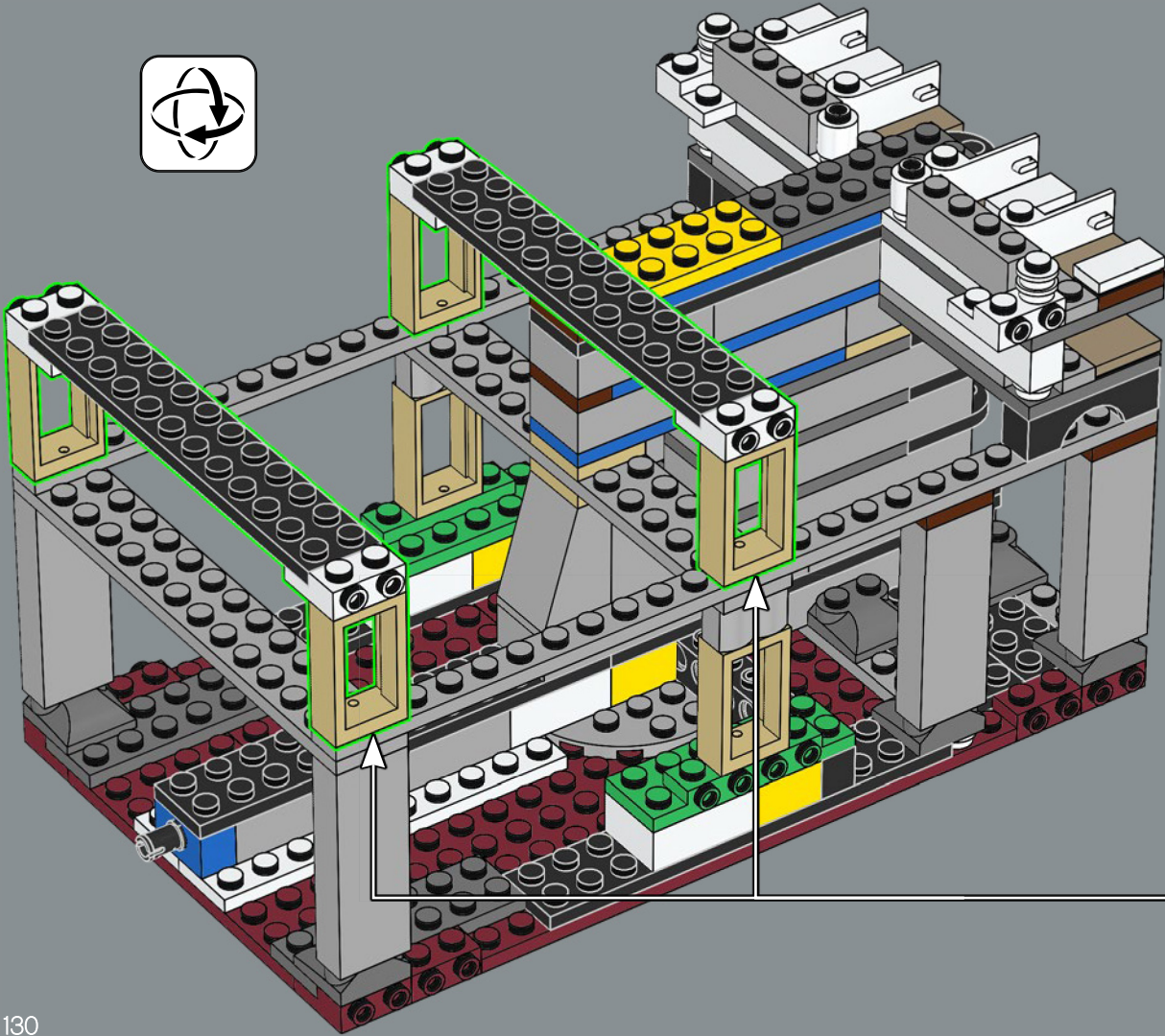

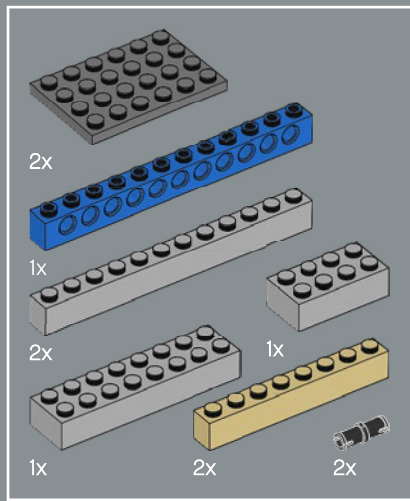

164

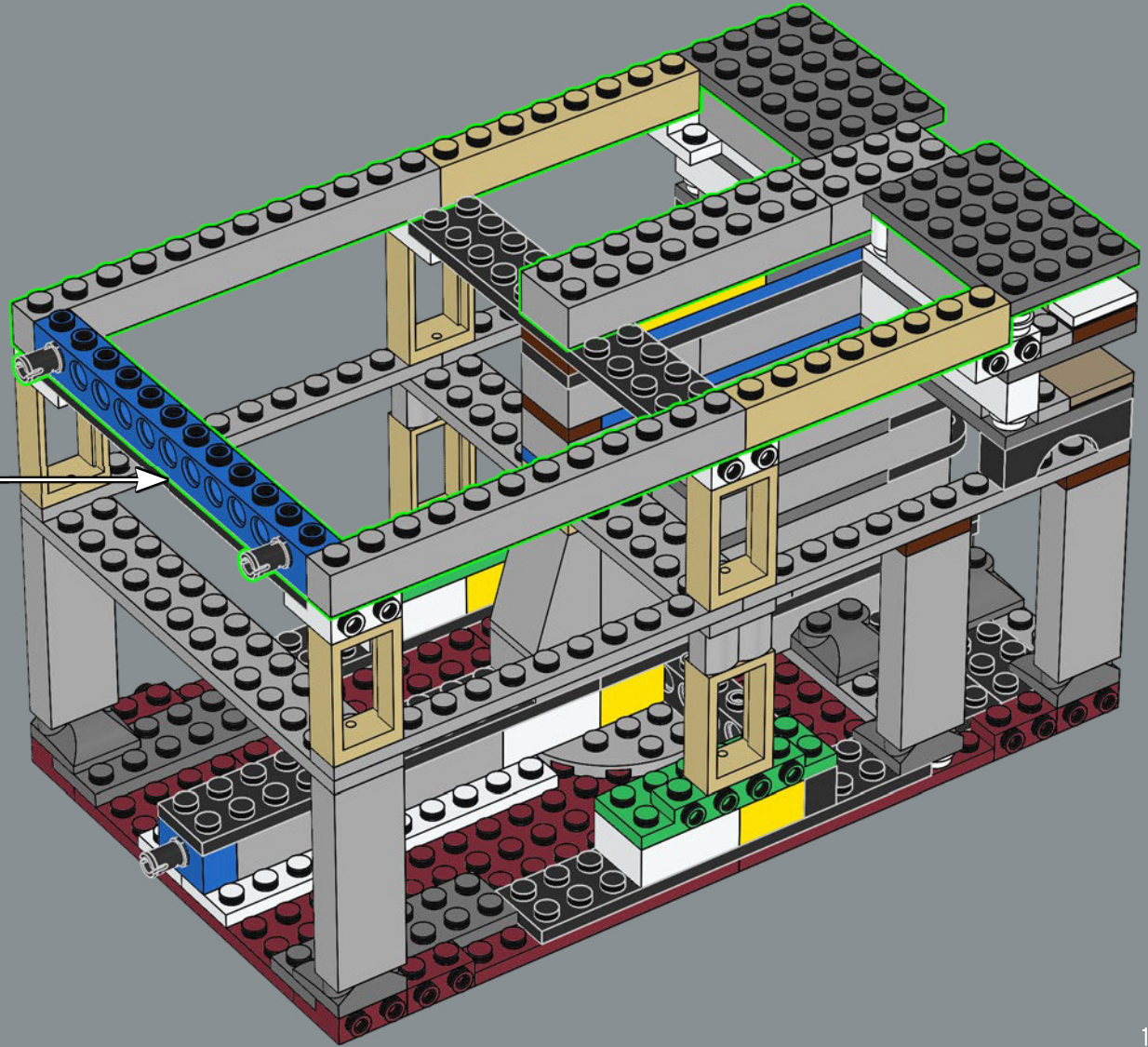
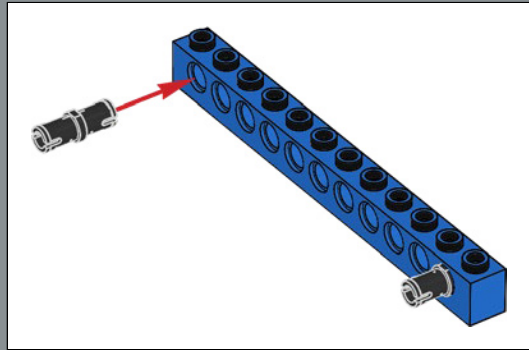

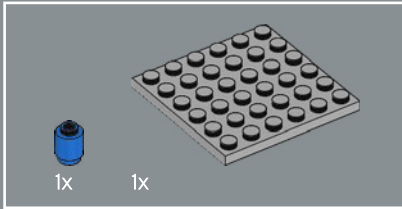
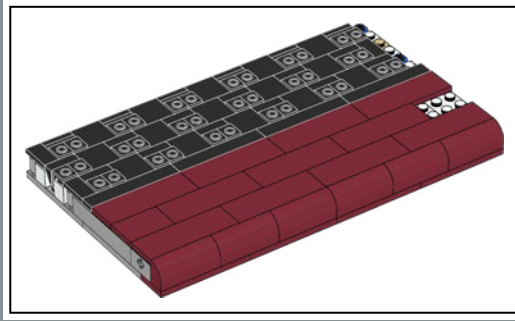
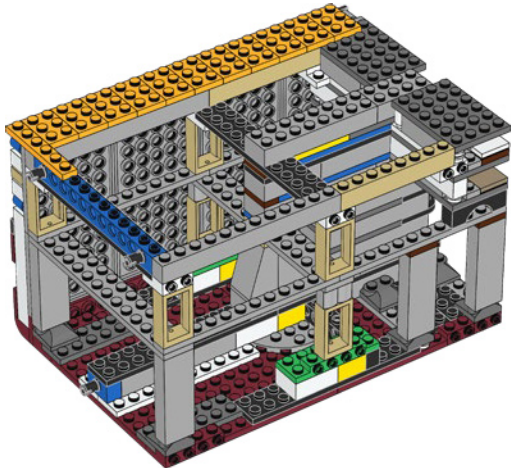
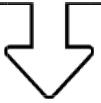

165

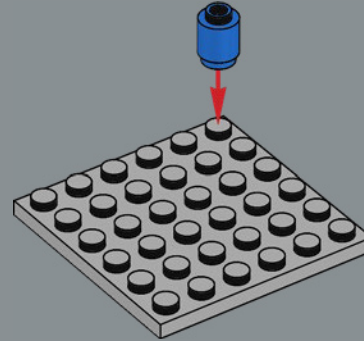

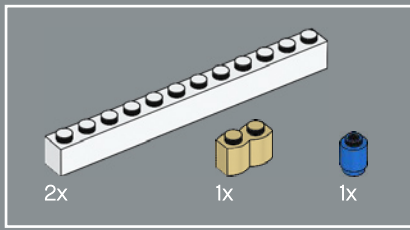

166

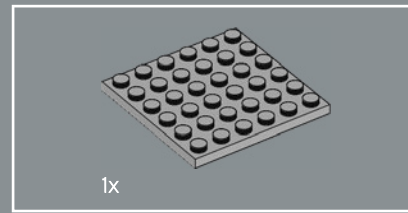
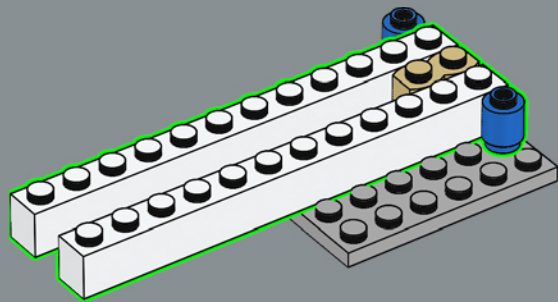

167

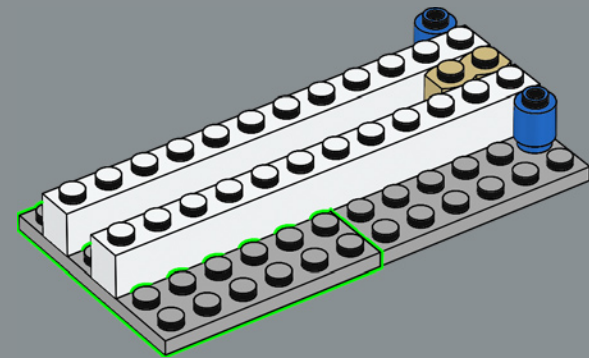

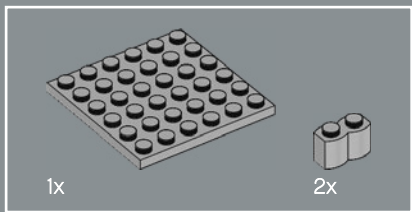

168

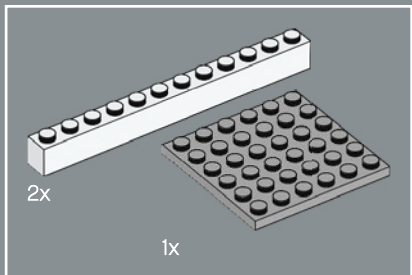
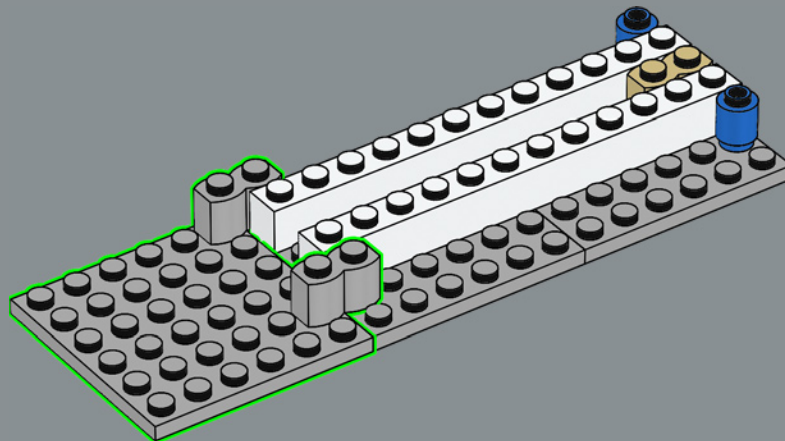

169

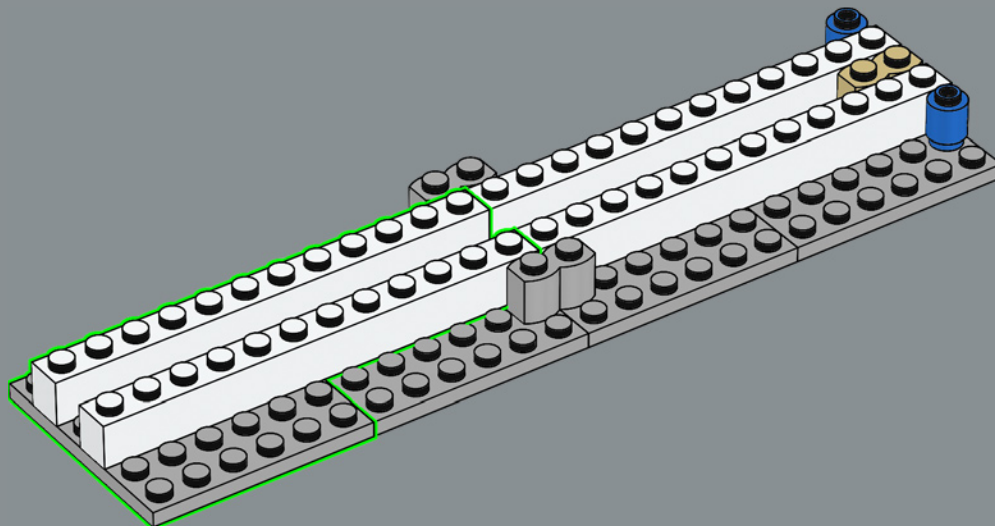

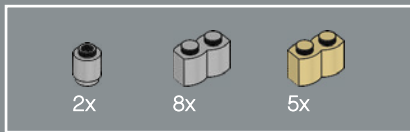

170

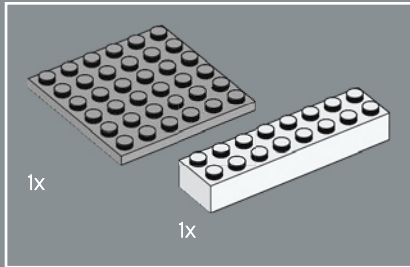
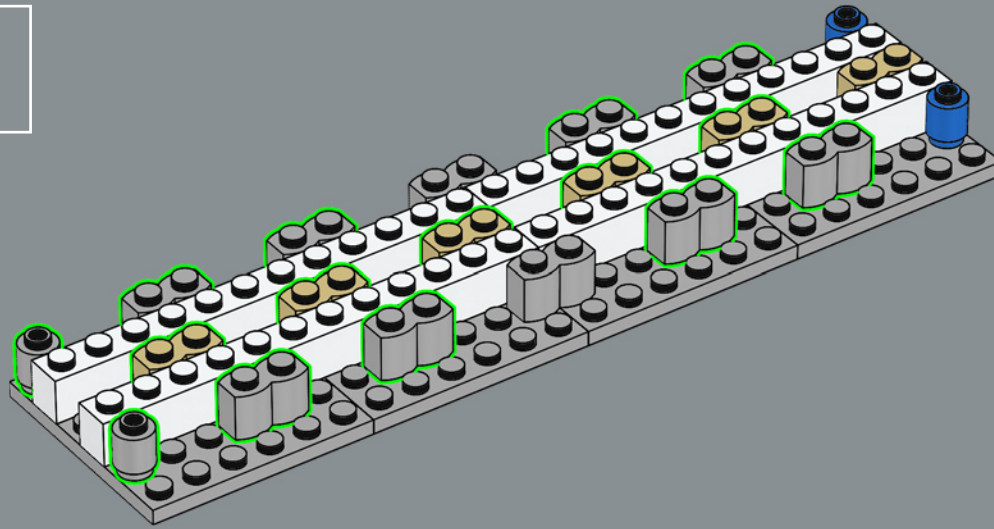

171

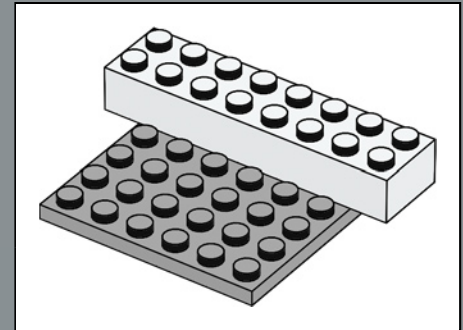
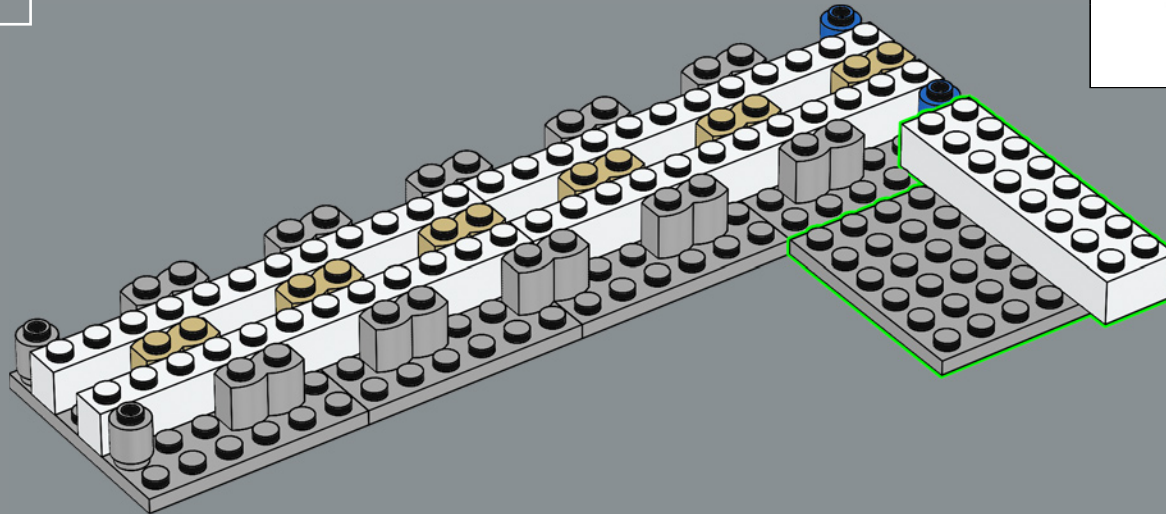

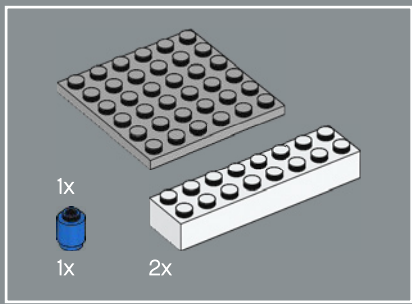

172

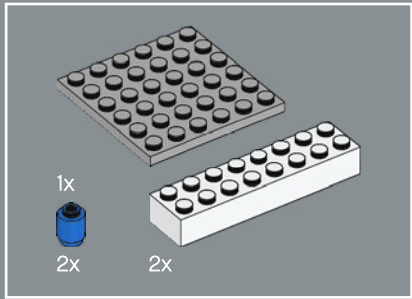
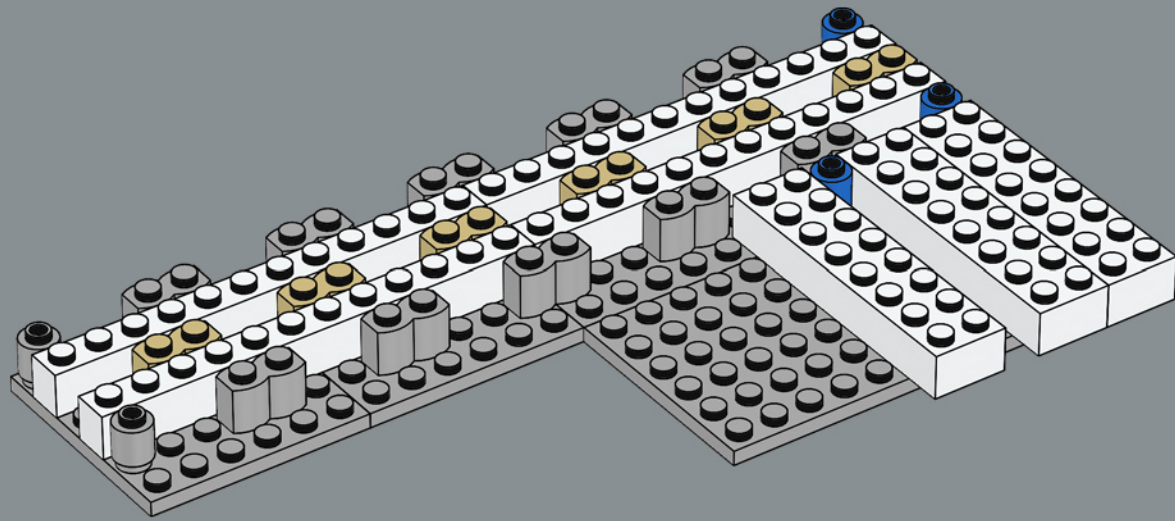

173

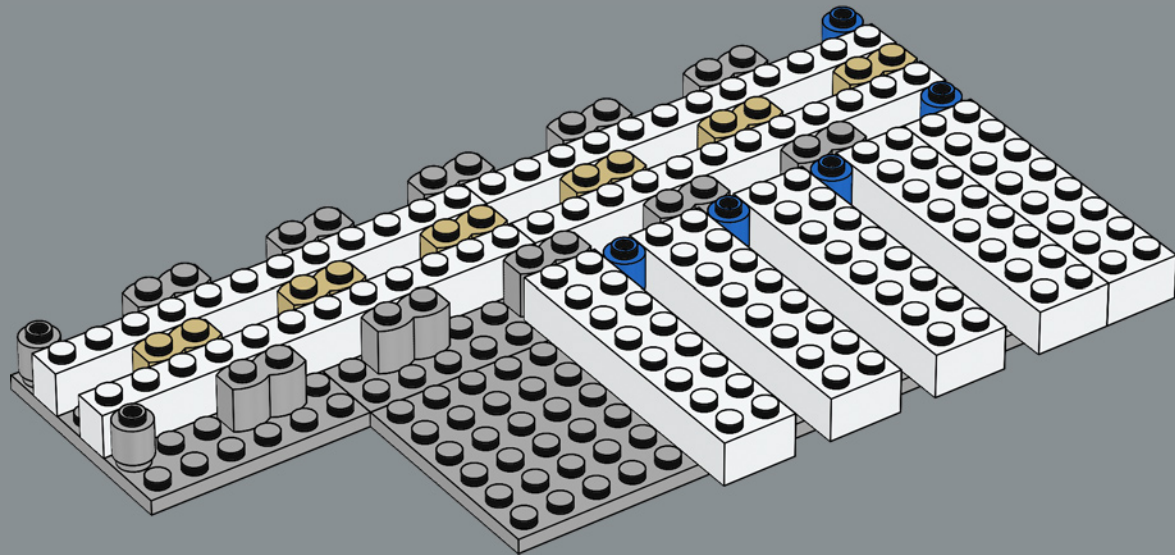

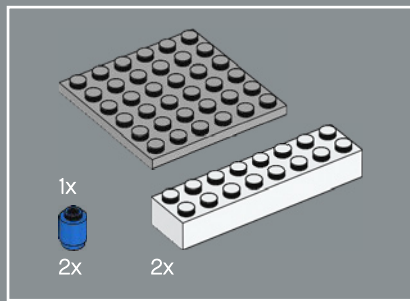

174

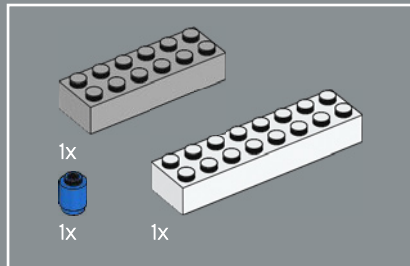
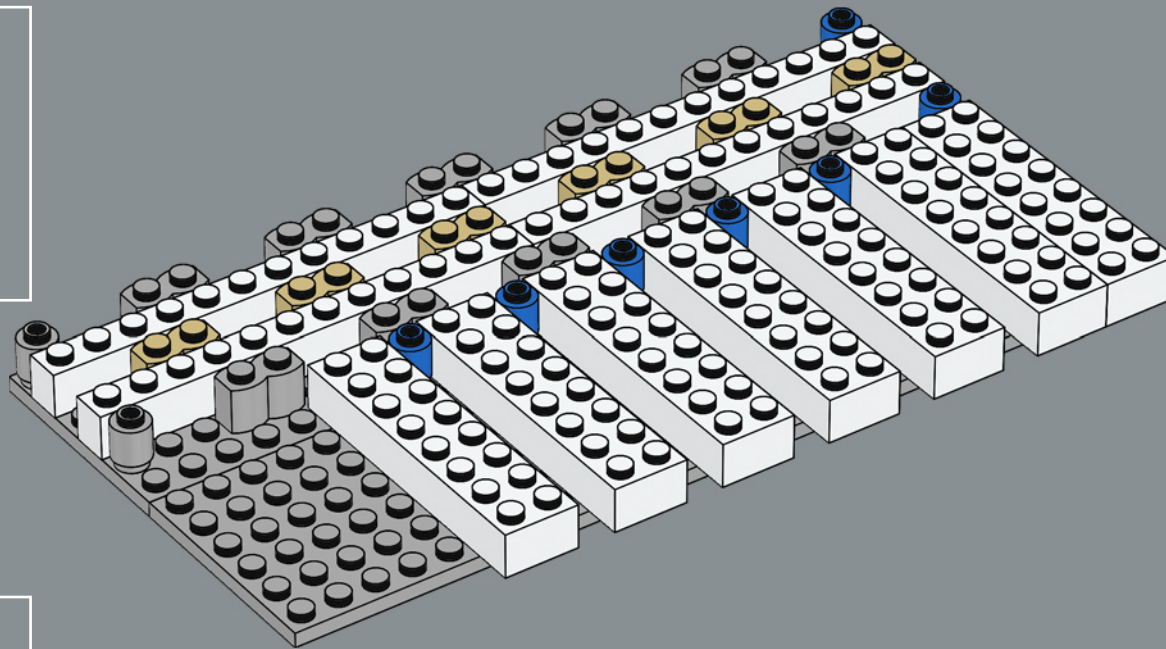

175



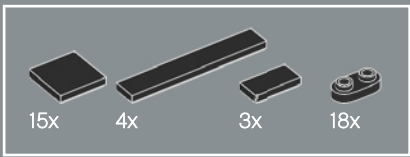

176

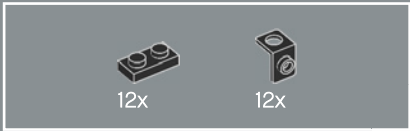
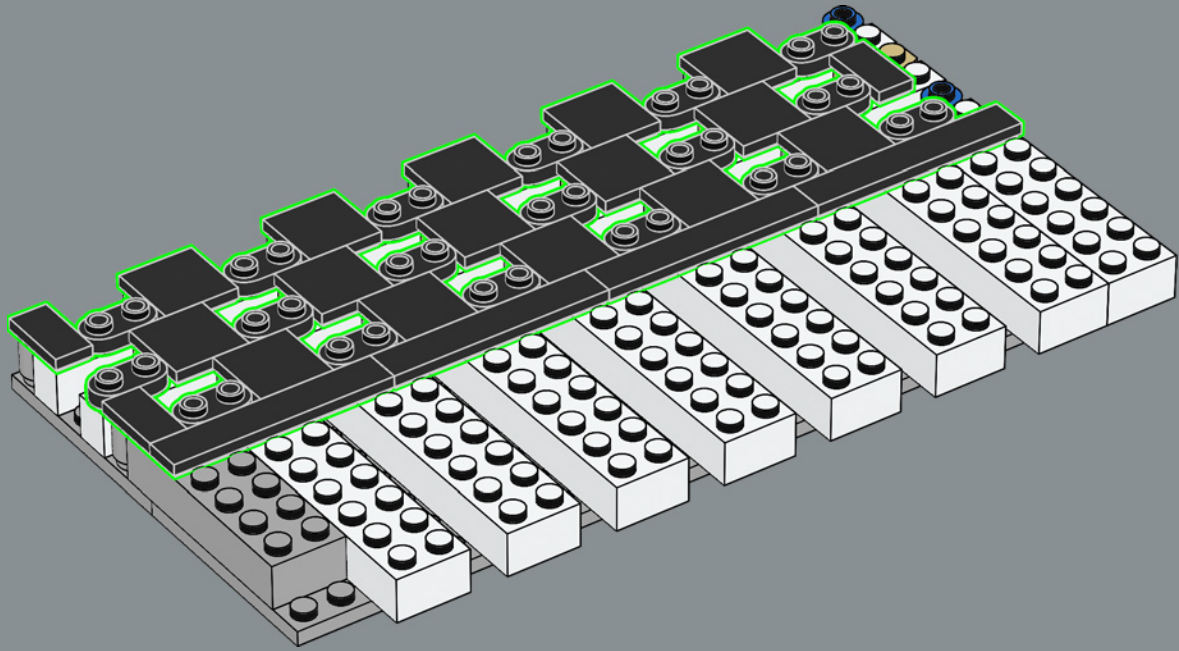

177

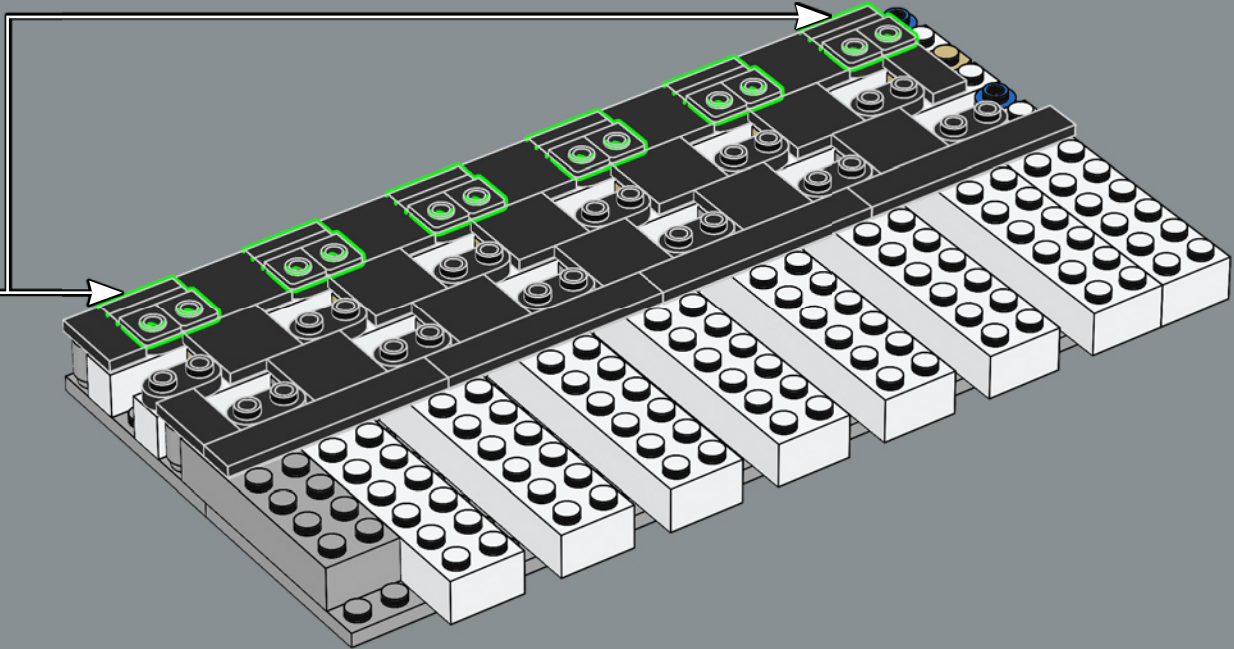
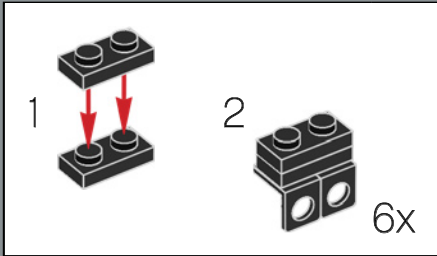



178

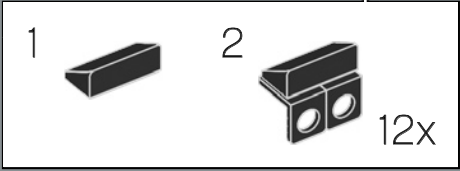
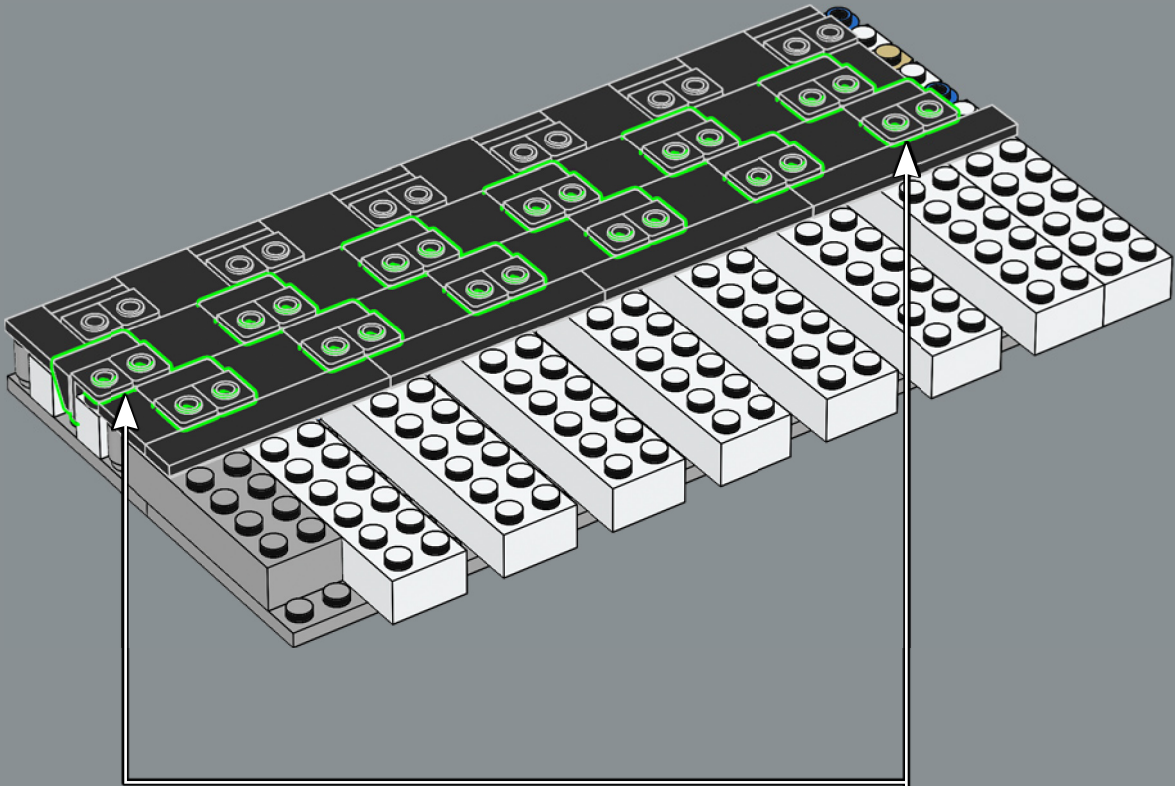

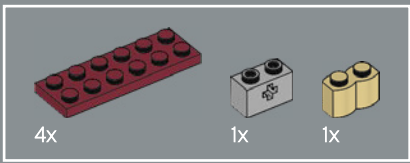

179

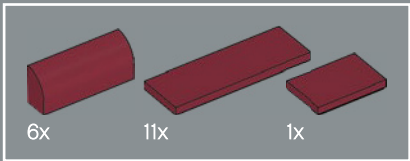
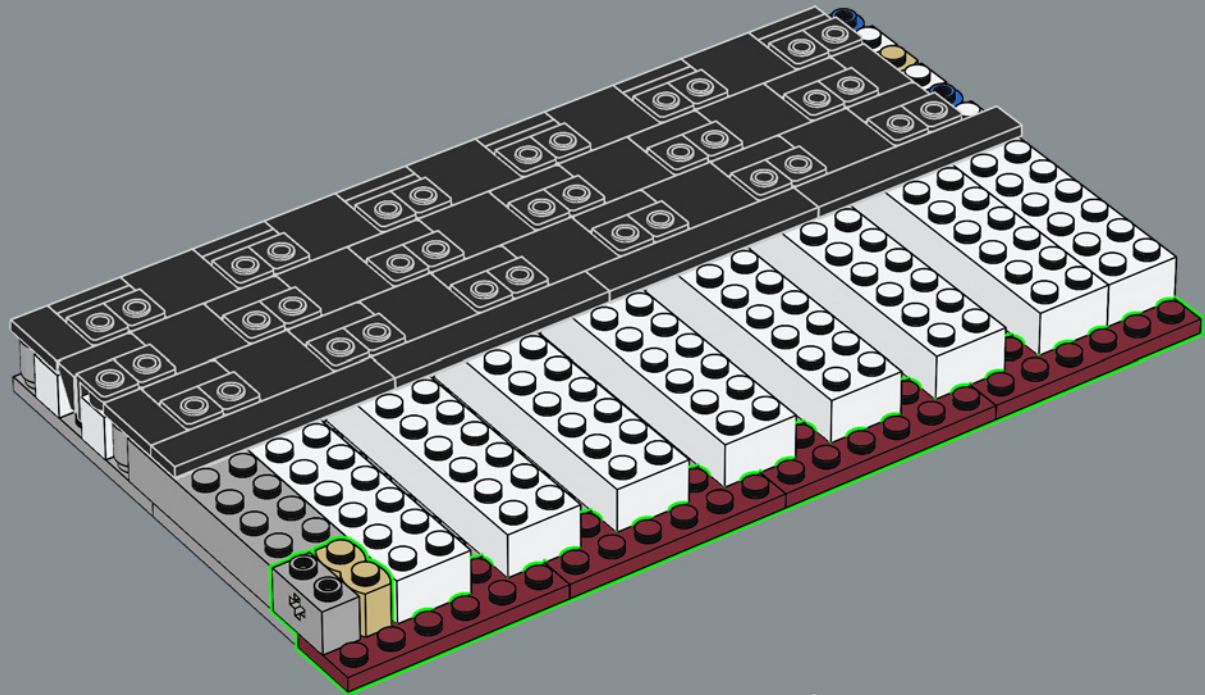

180

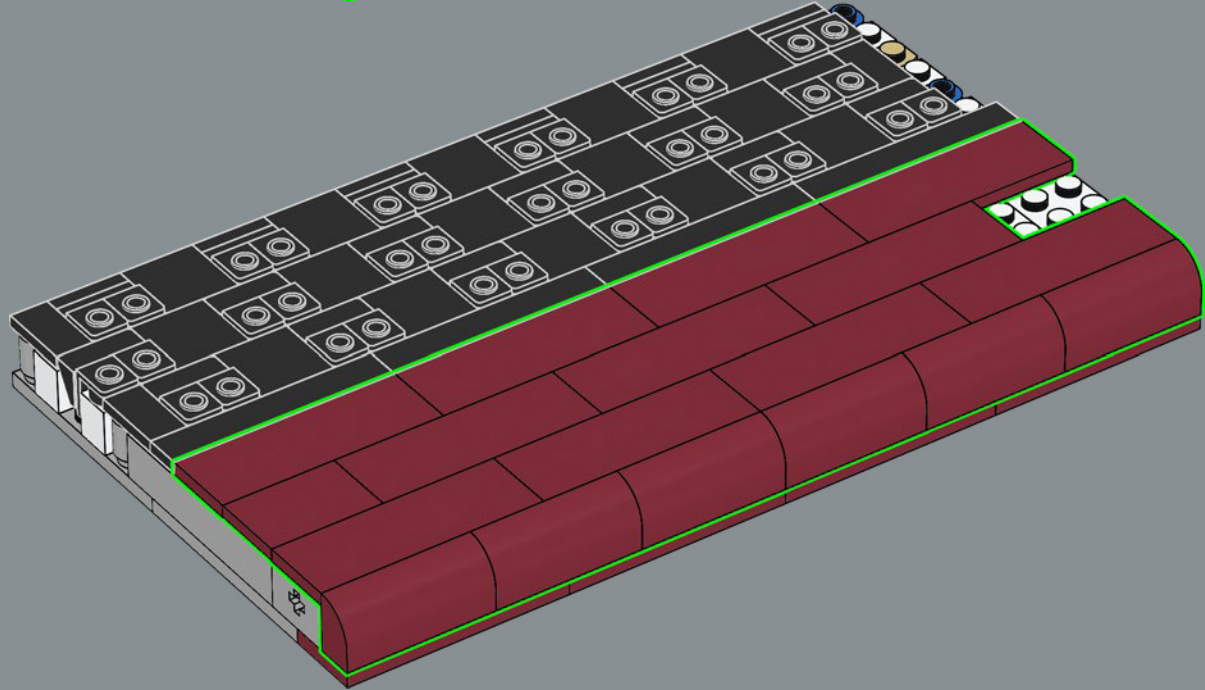

El casco del barco estaba formado por planchas unidas con más de tres millones de remaches de hierro y acero que pesaban 1200 t aproximadamente.

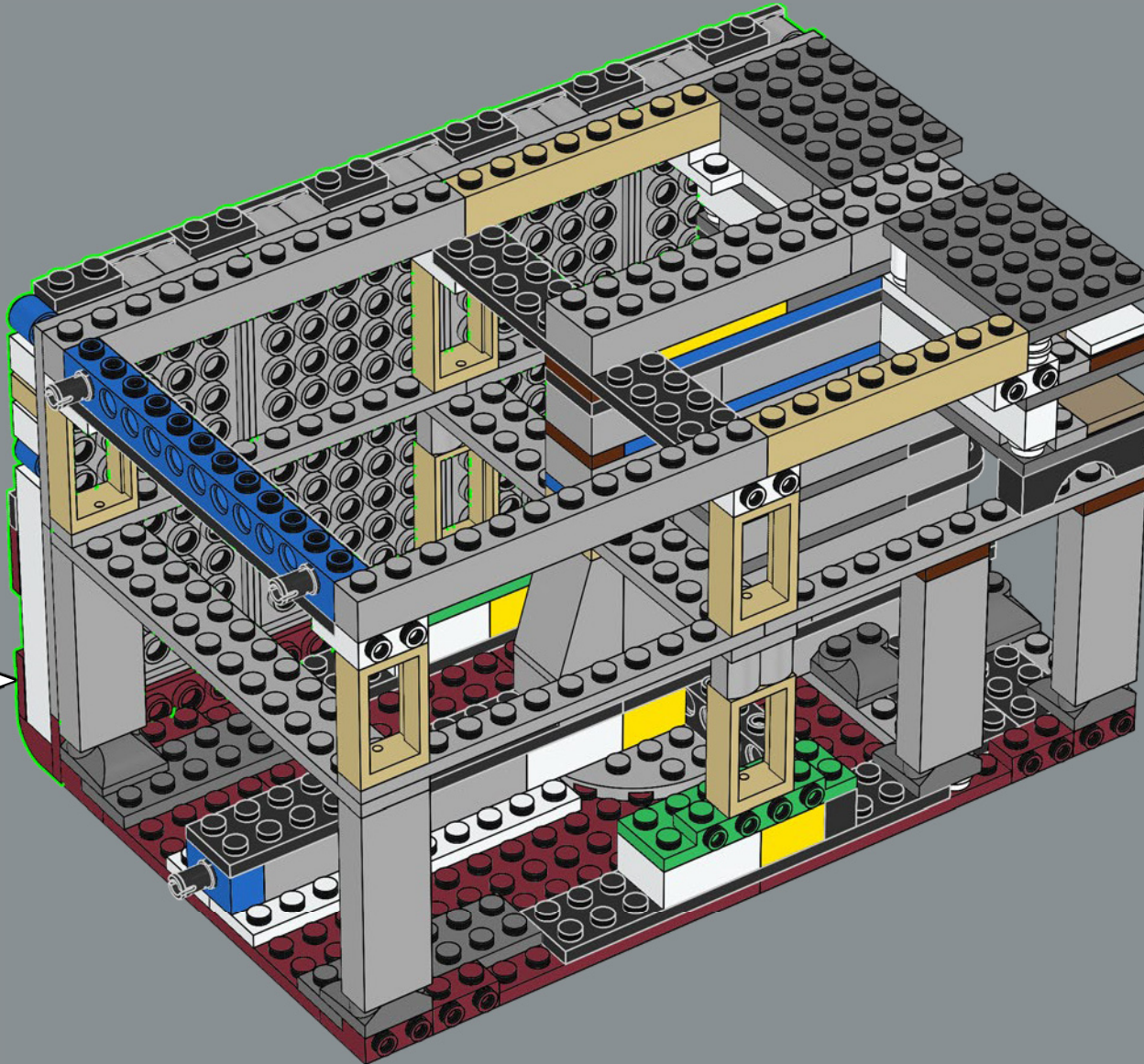

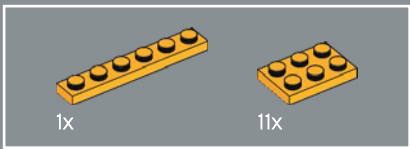

182

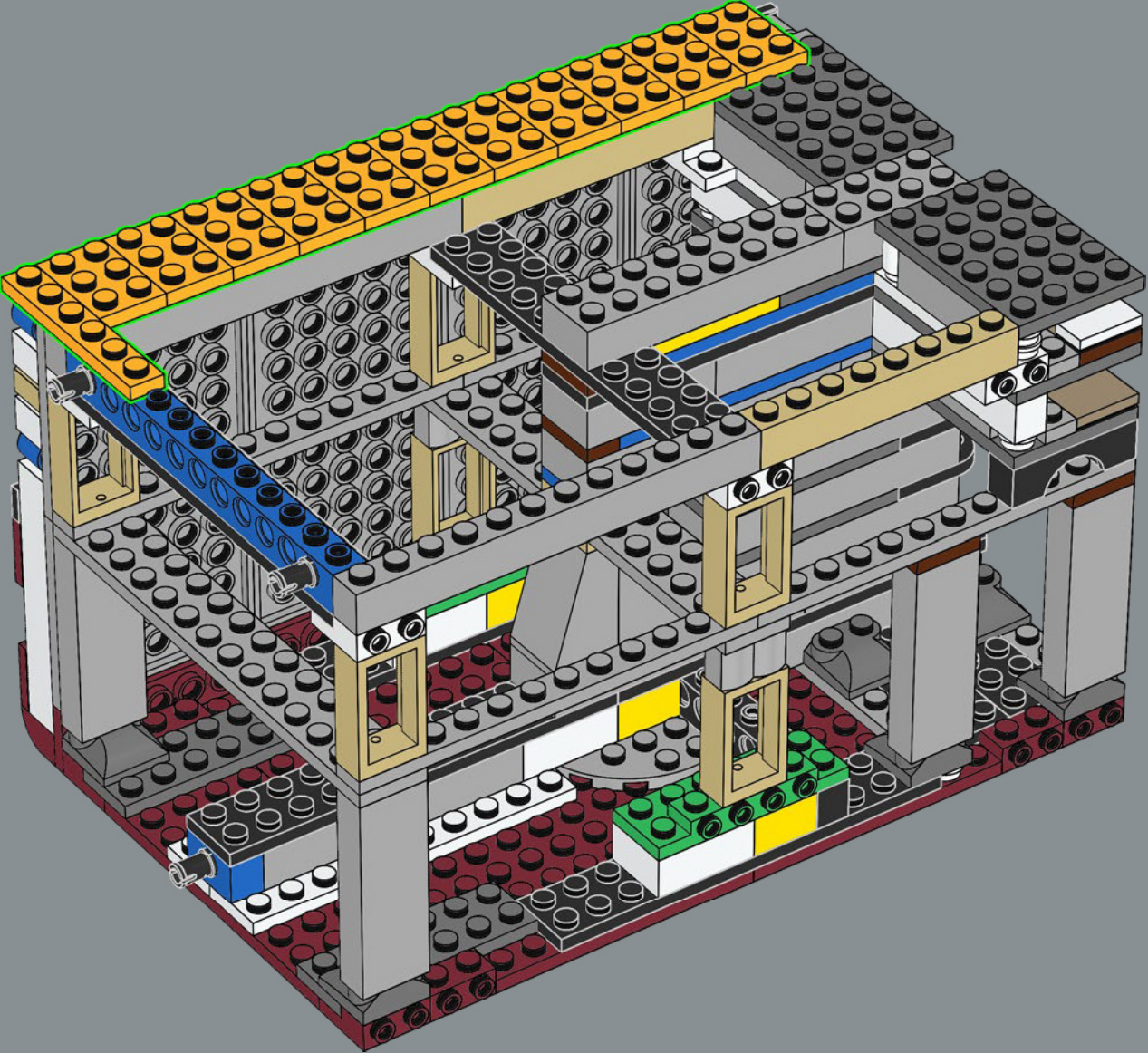

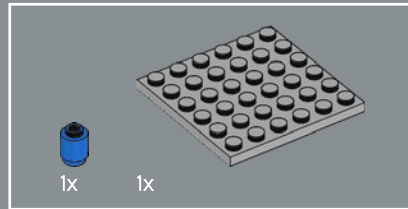
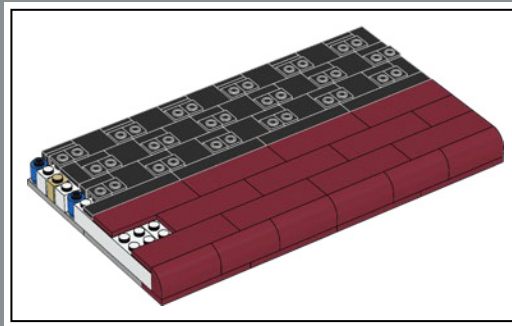
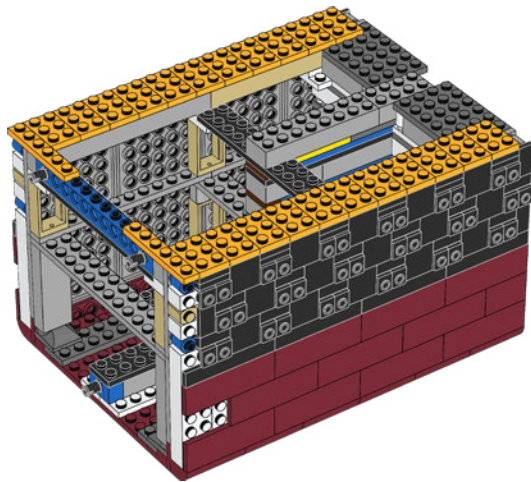
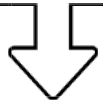

183

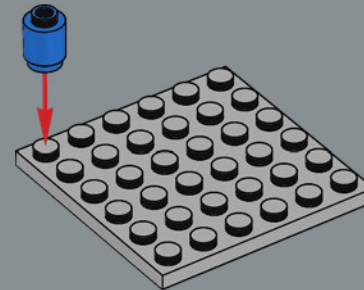

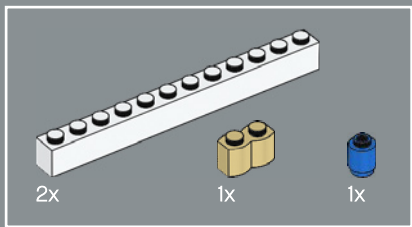

184

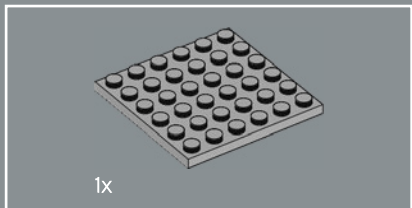
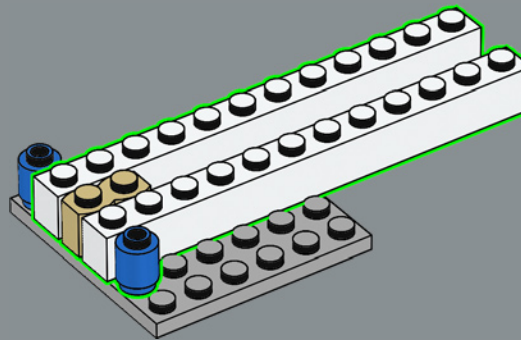

185

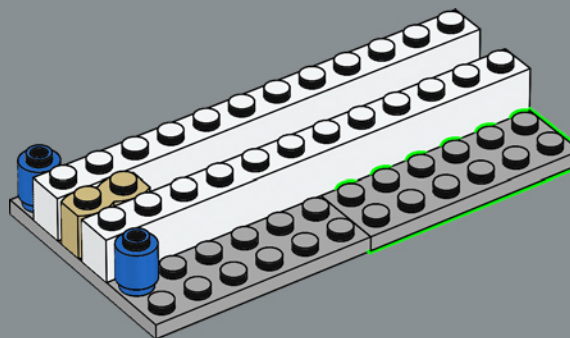

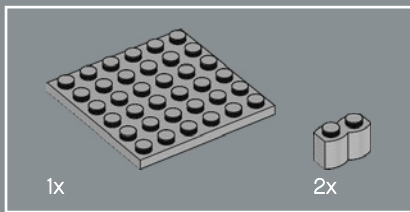

186

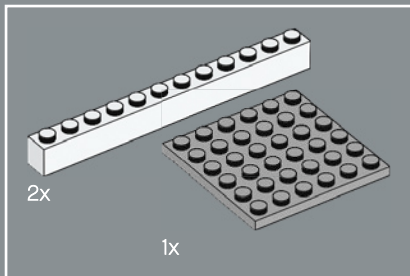
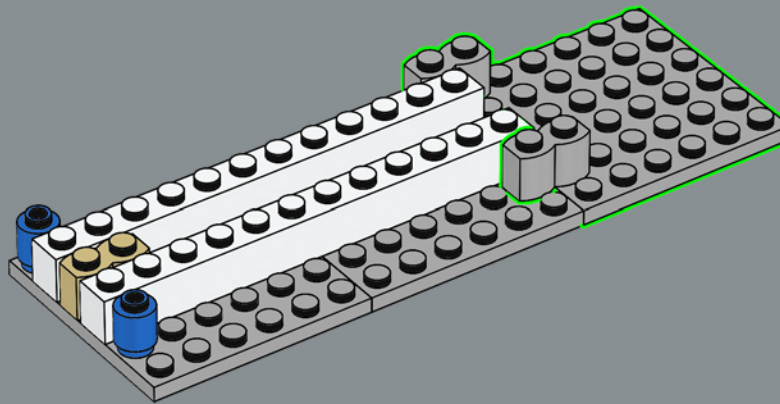

187

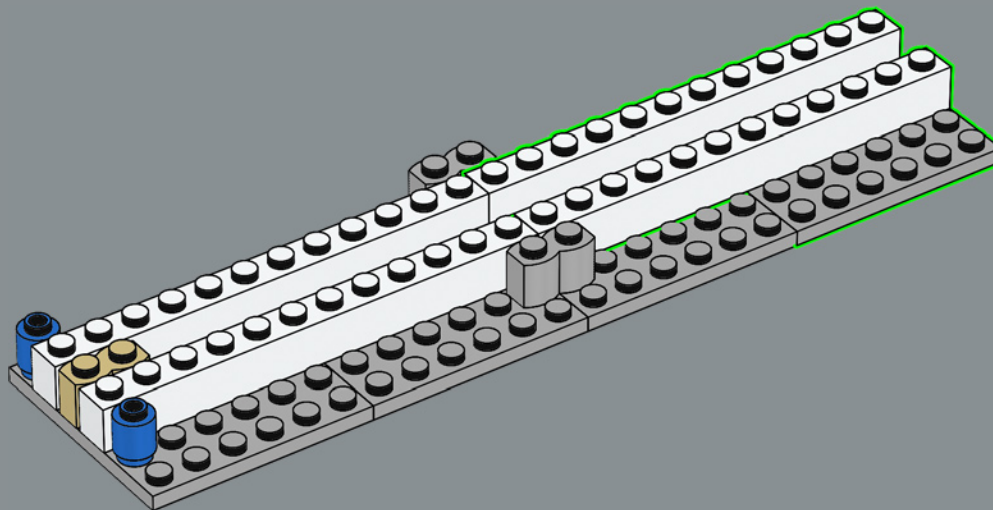



188

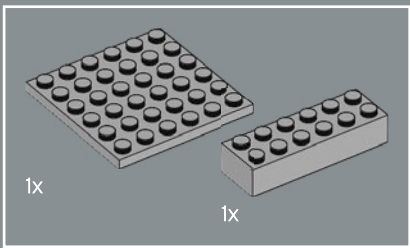
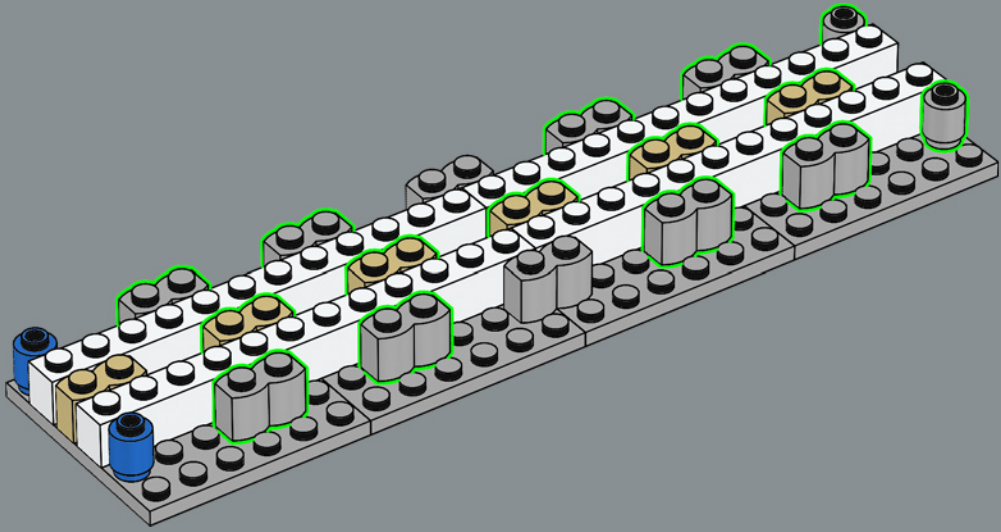

189

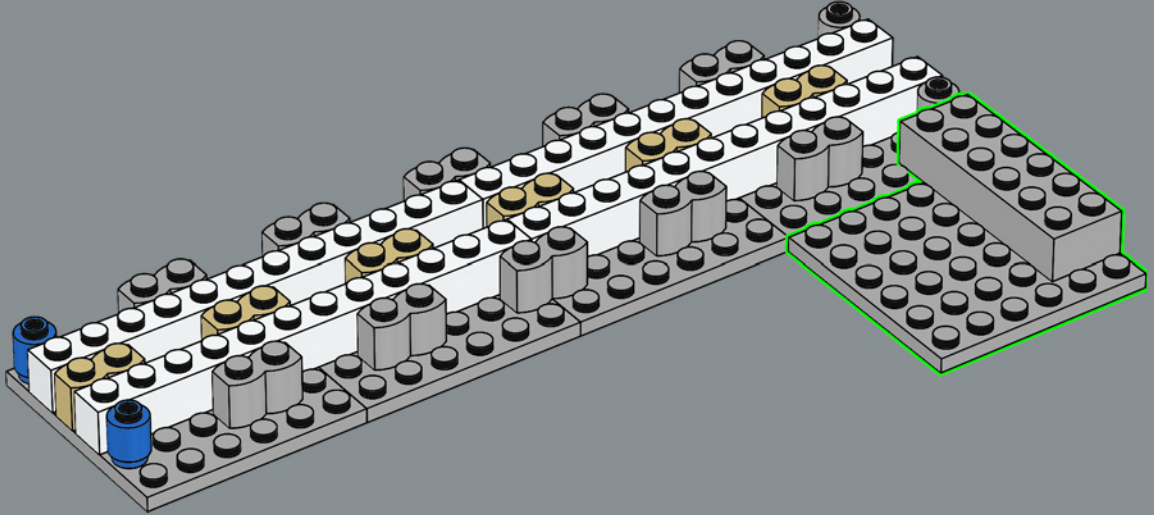

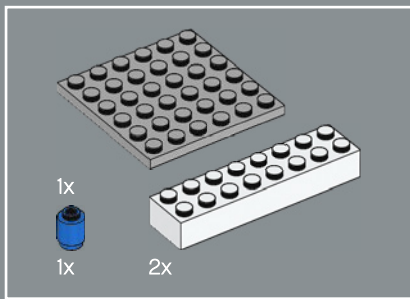

190

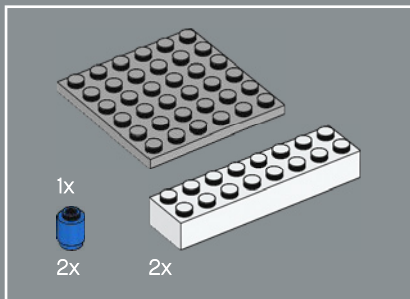
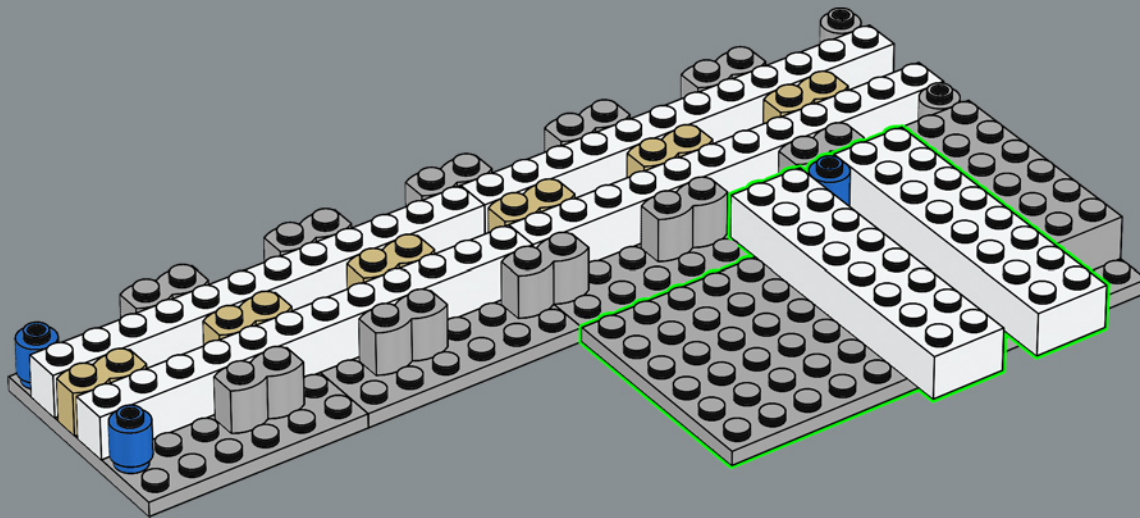

191

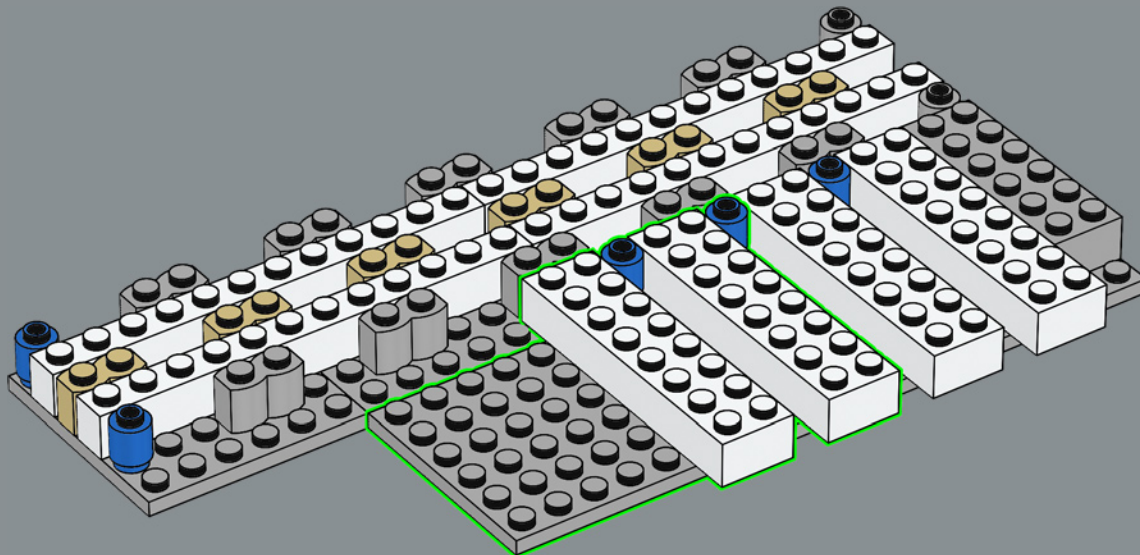

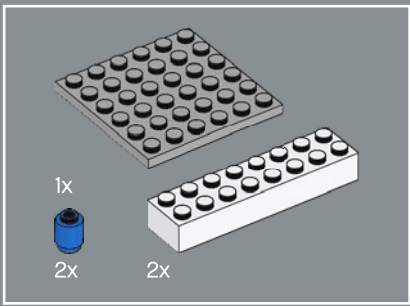

192

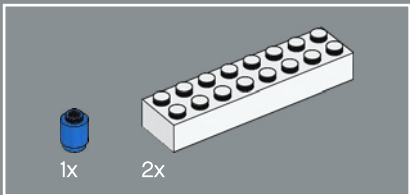
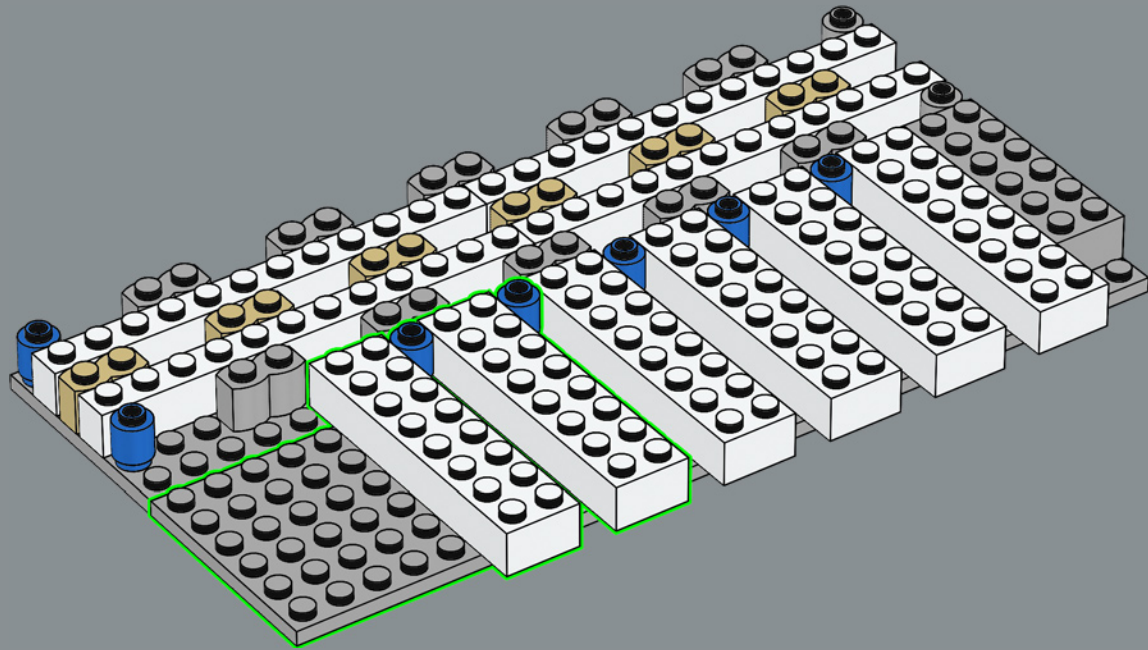

193

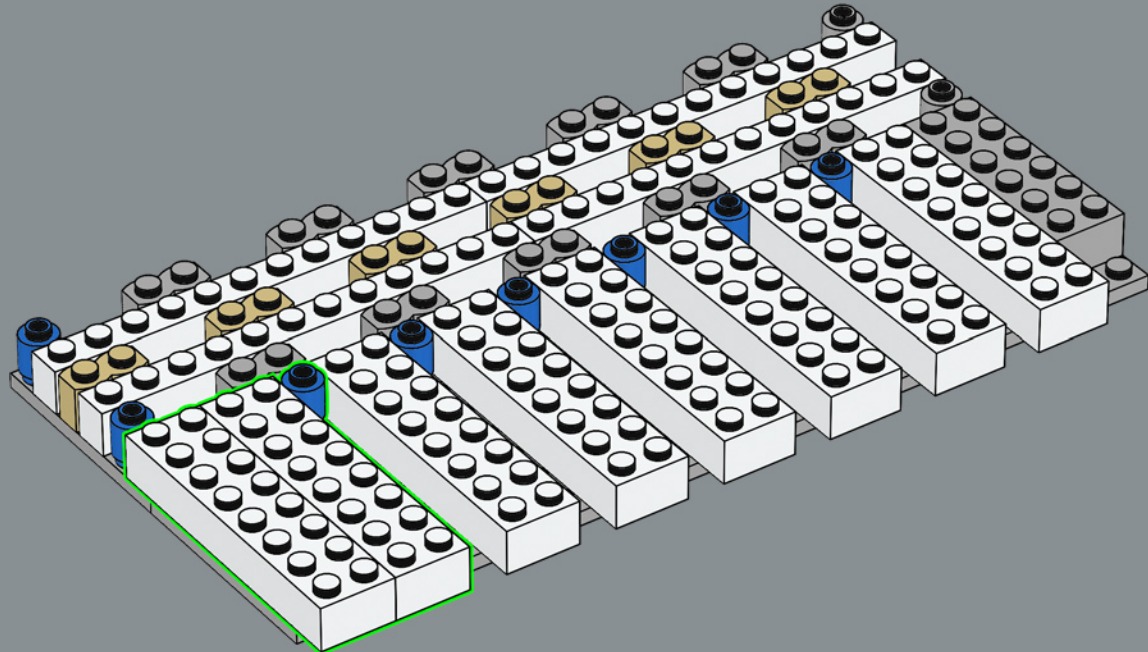

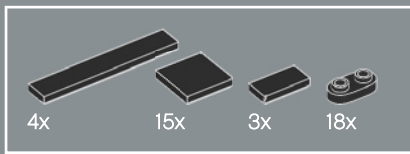

194

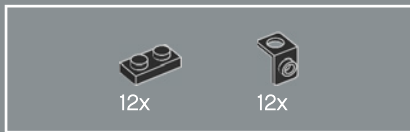
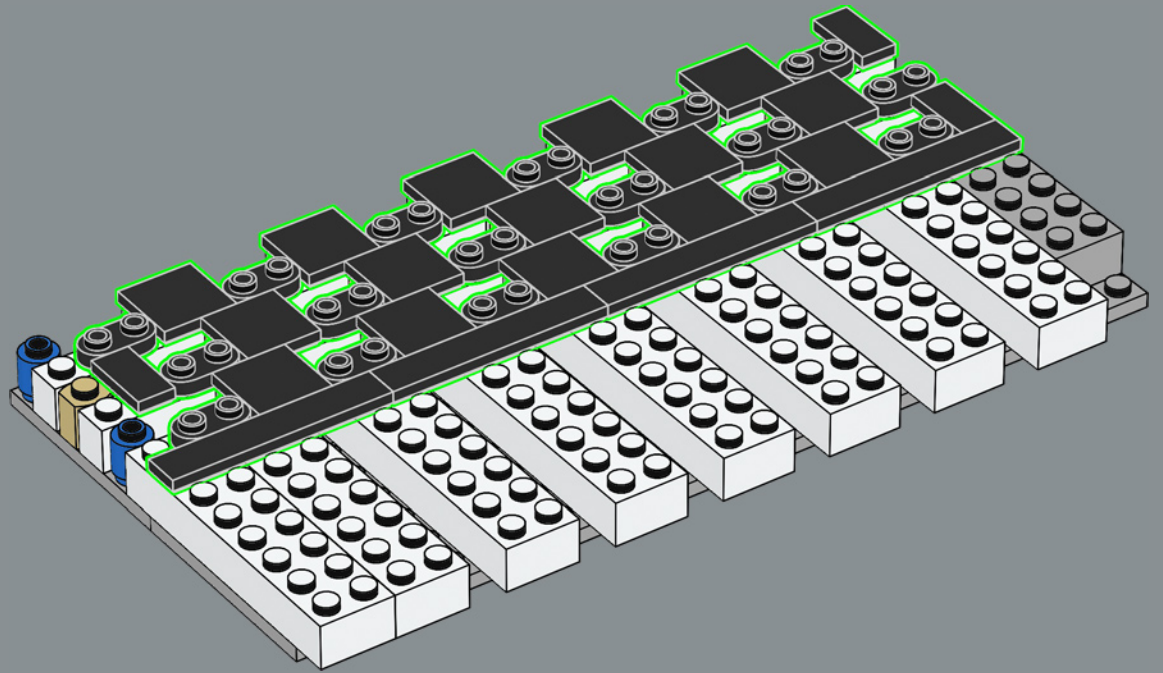

195

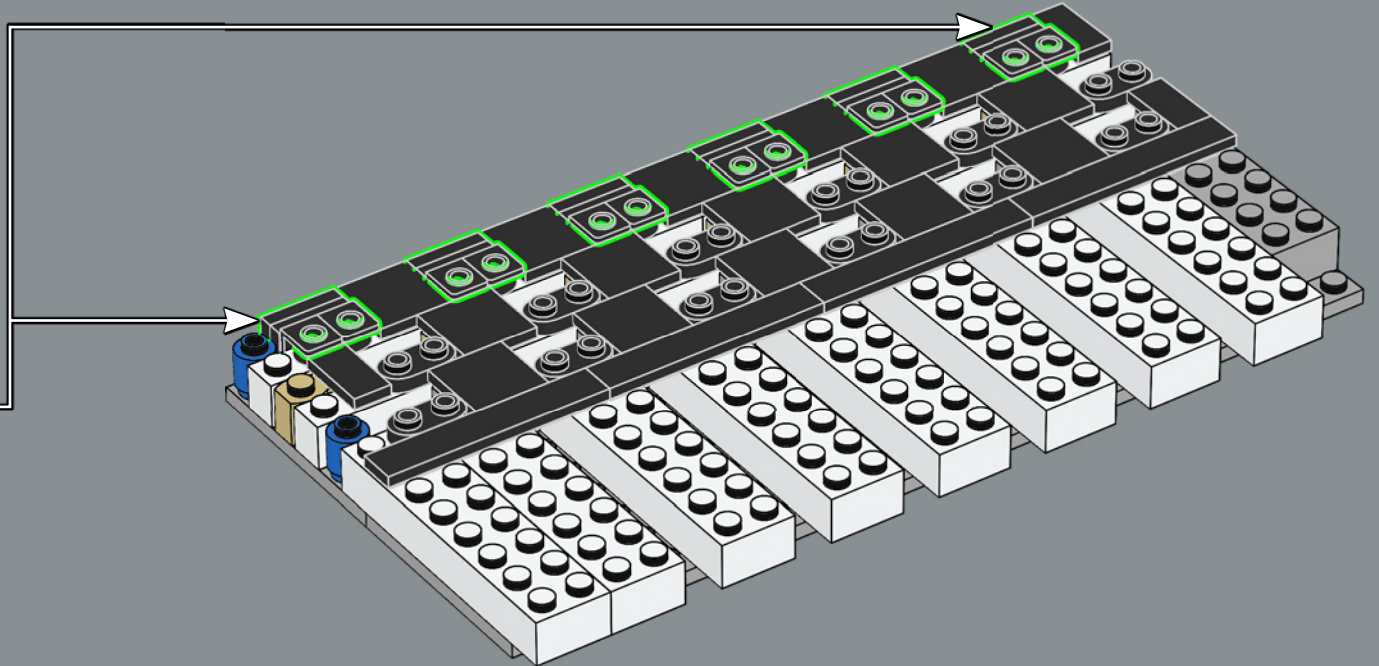
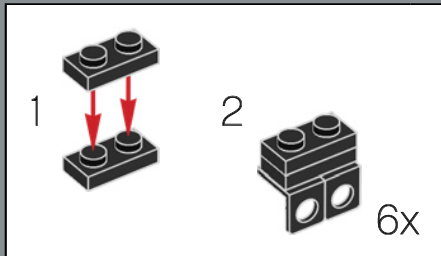



196

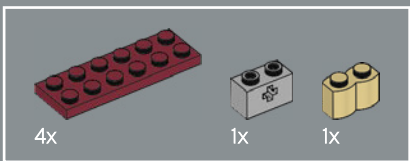
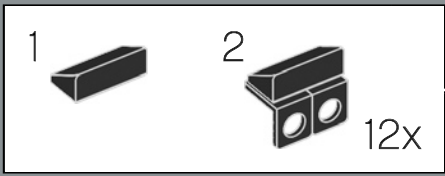
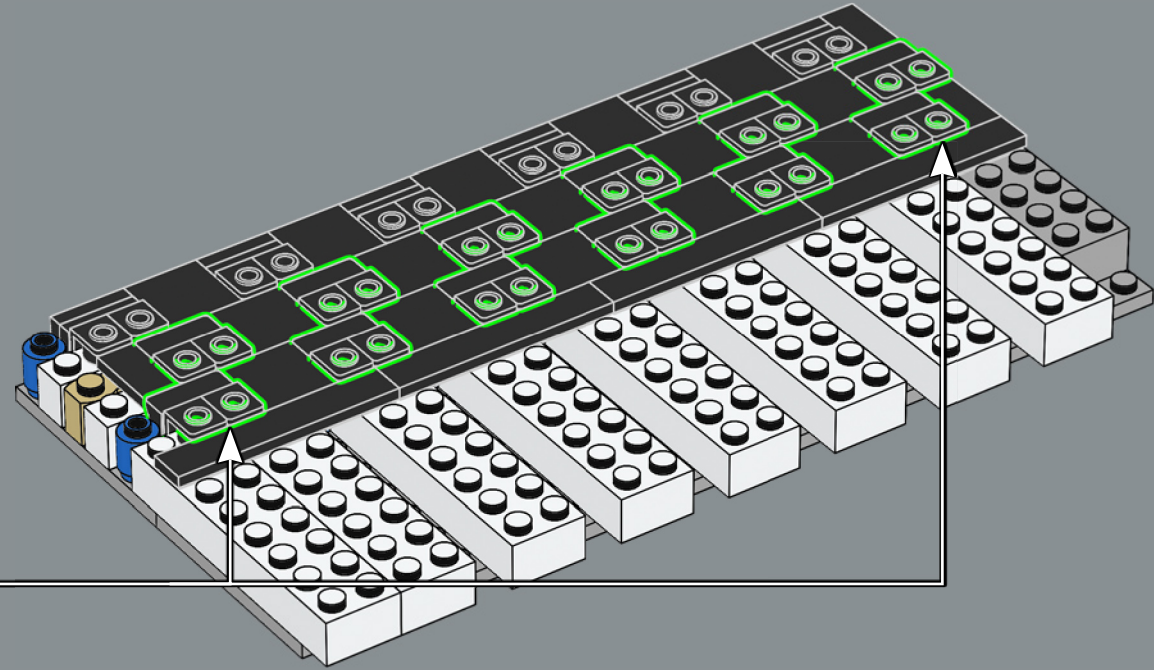

197

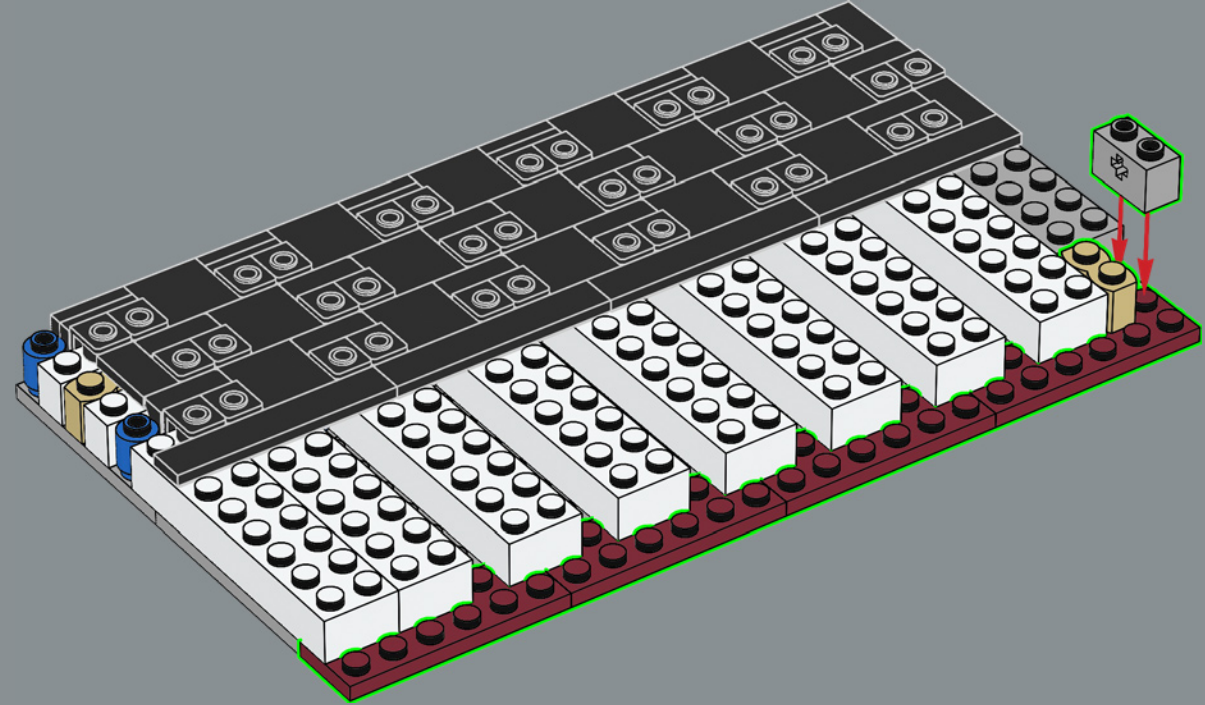

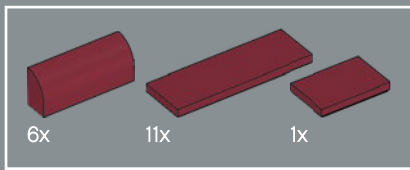

198

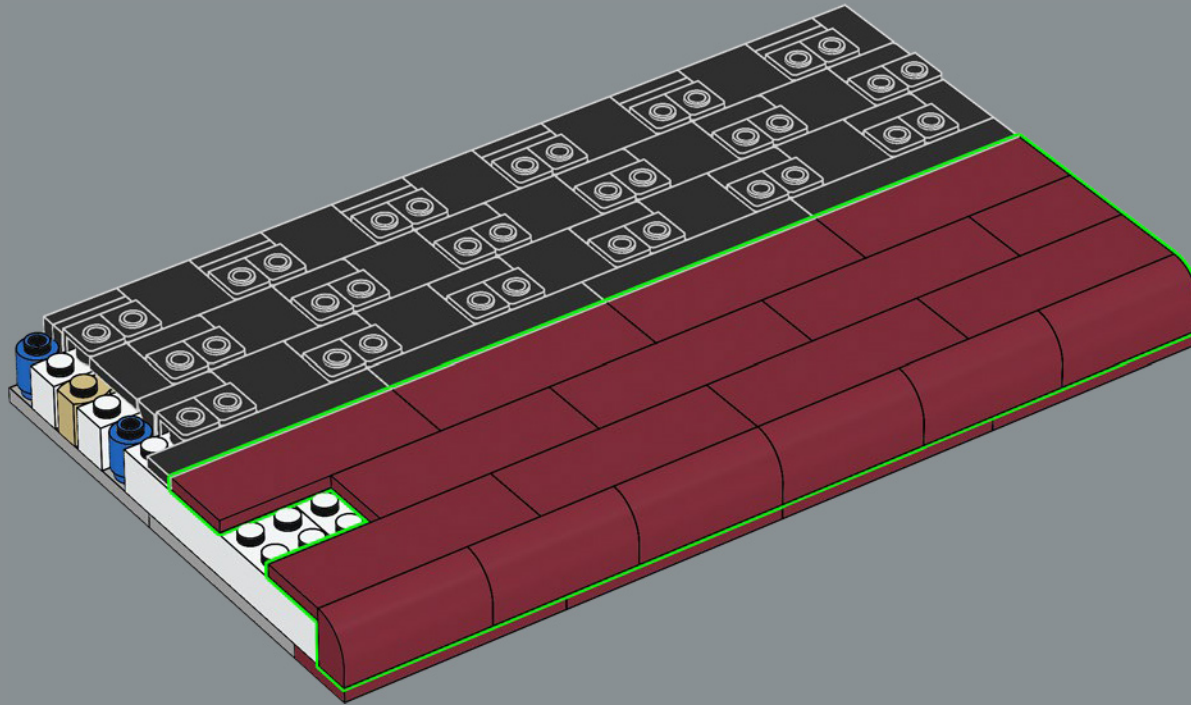

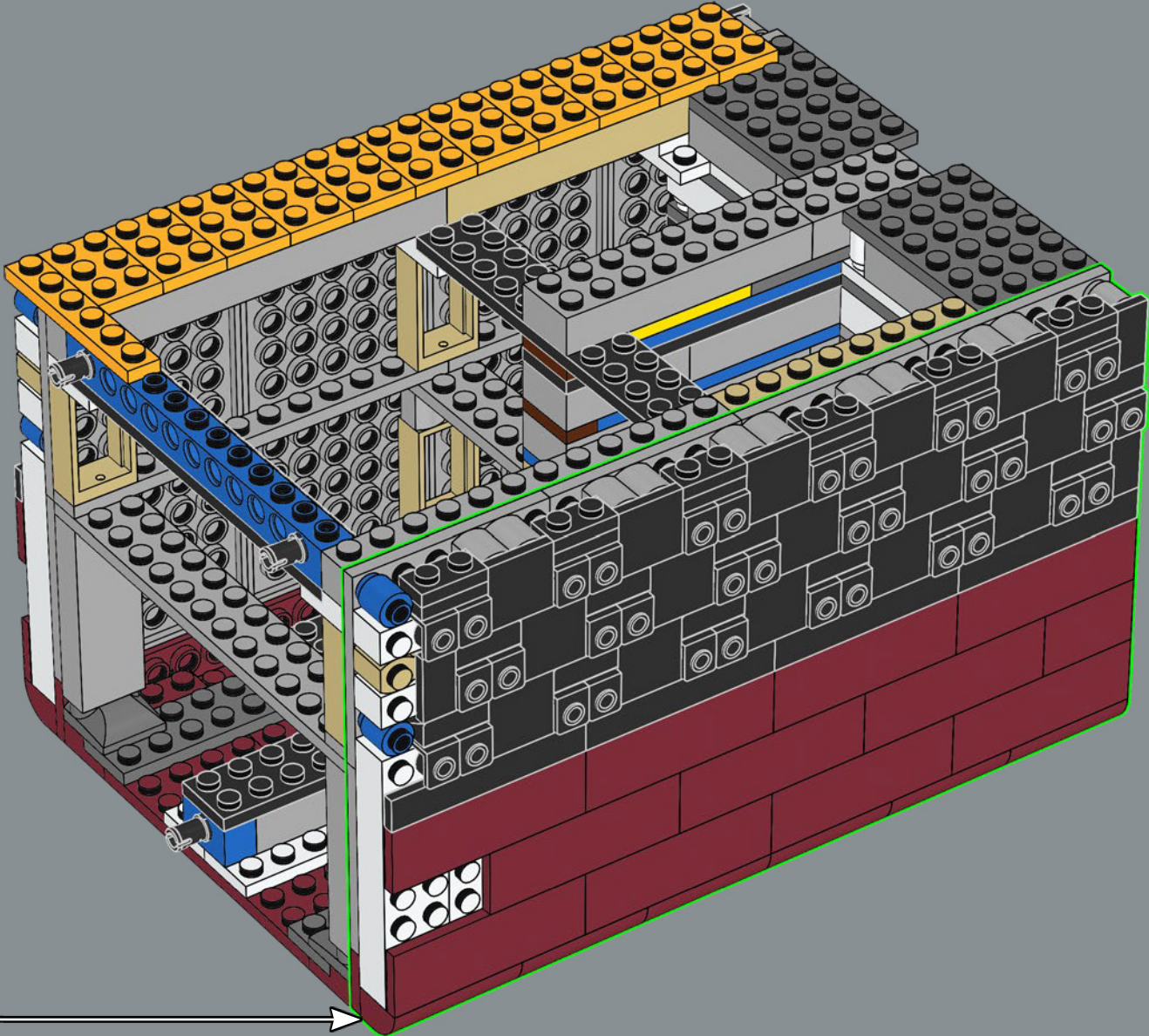

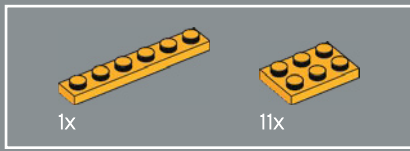

200

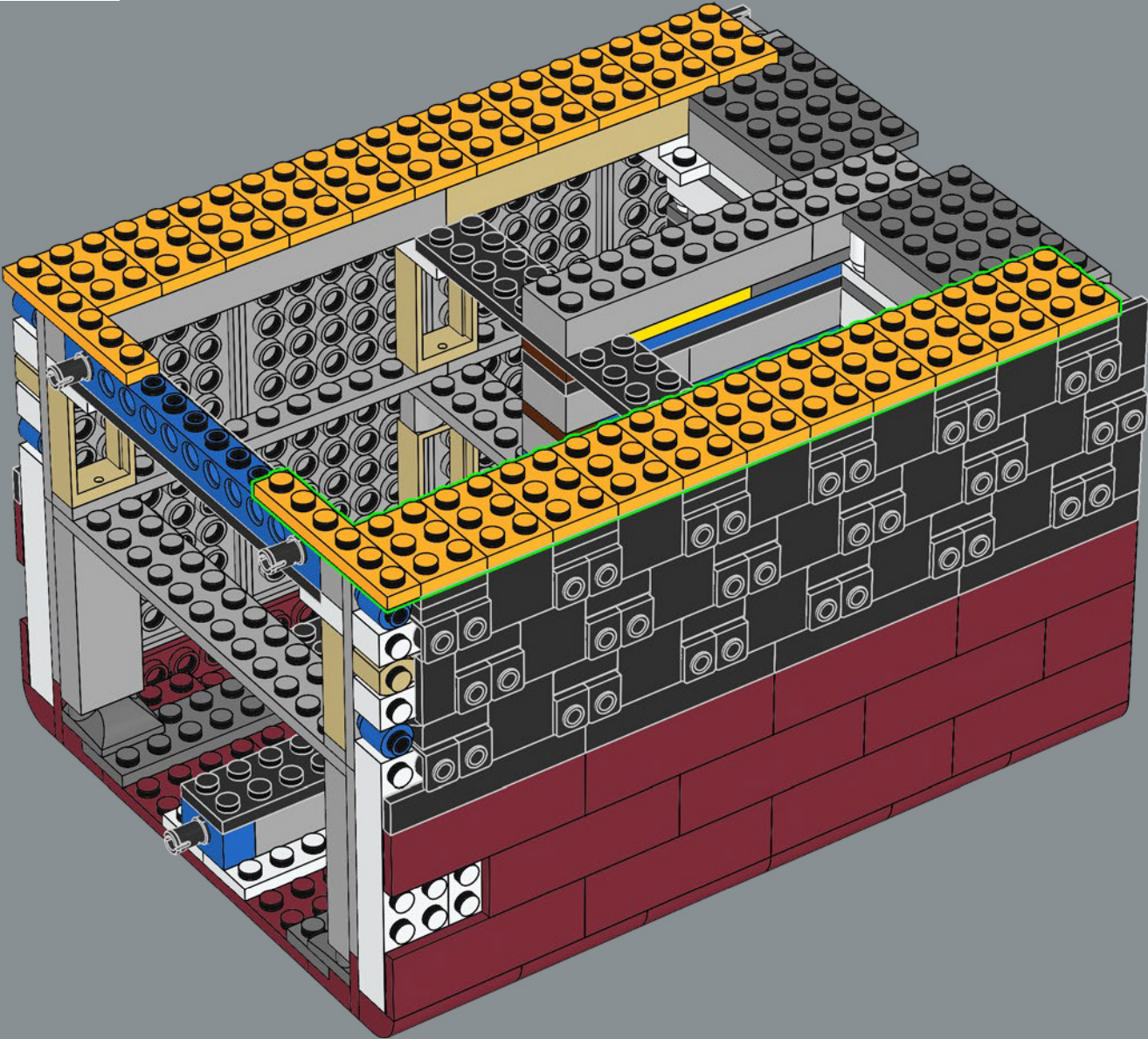

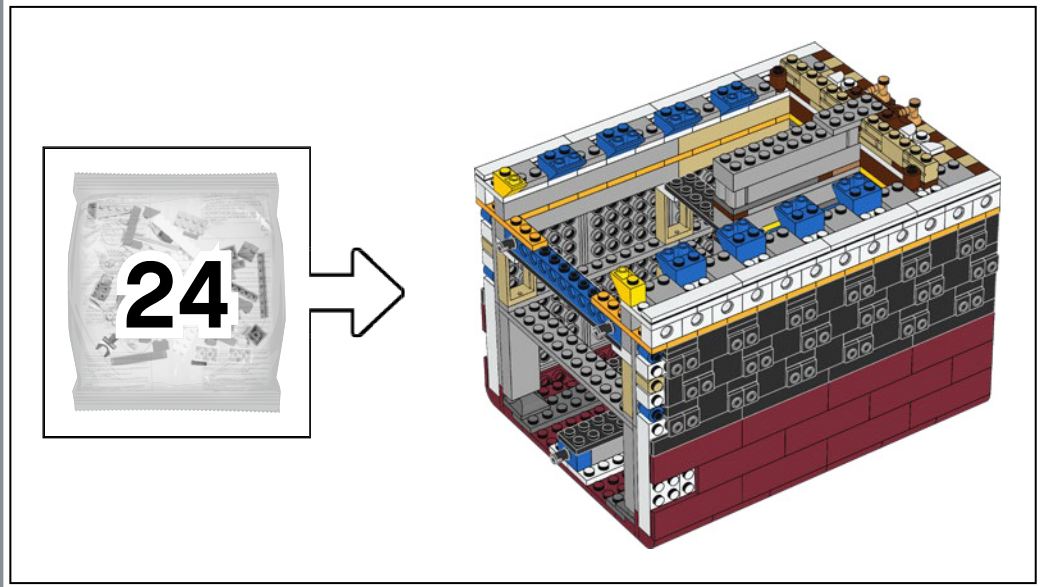

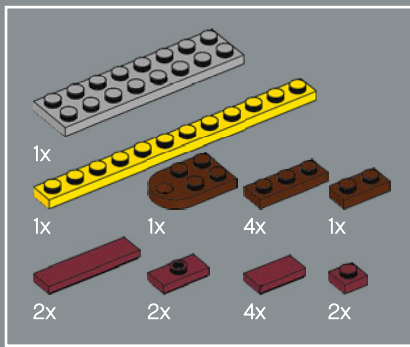

201

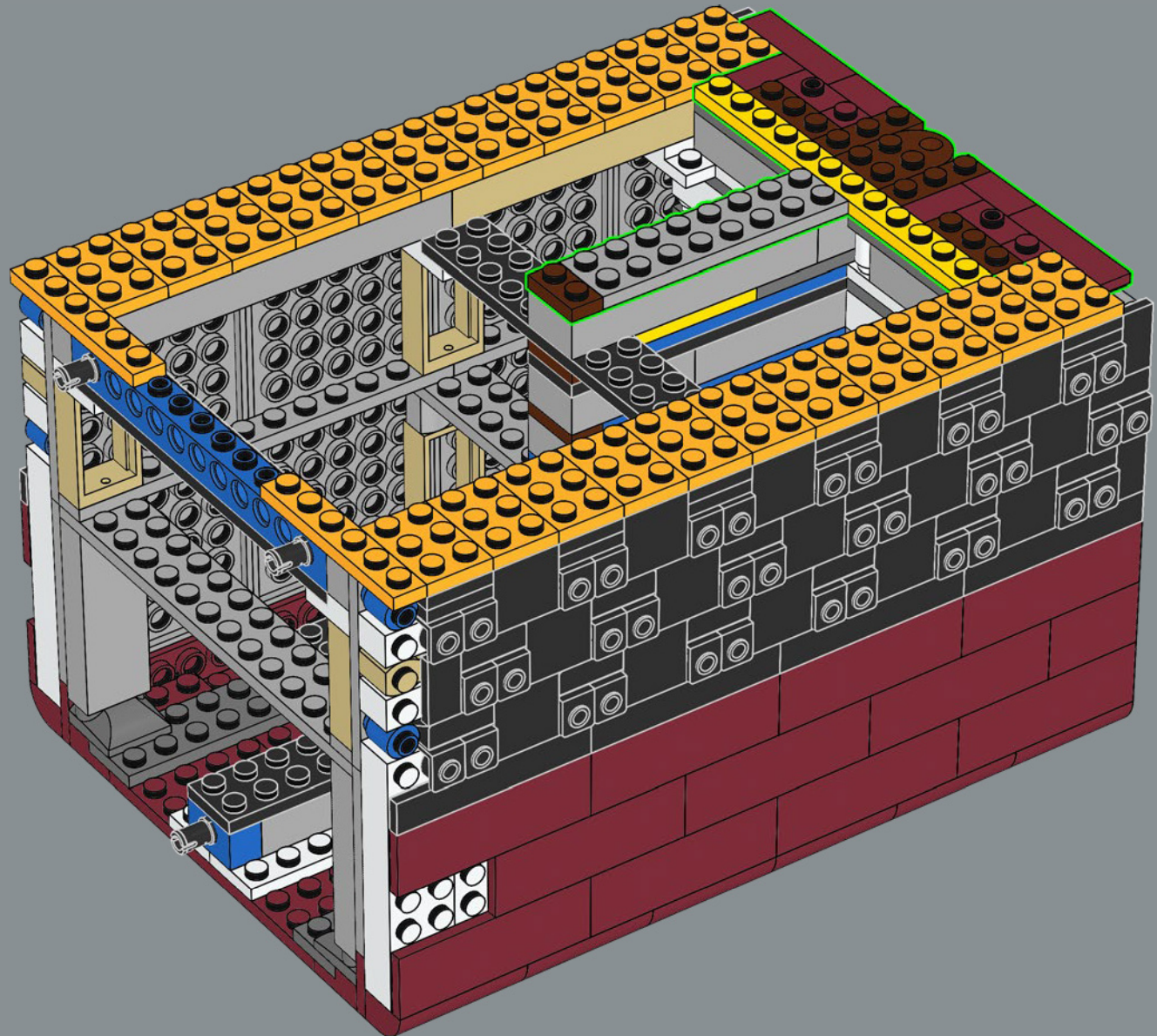

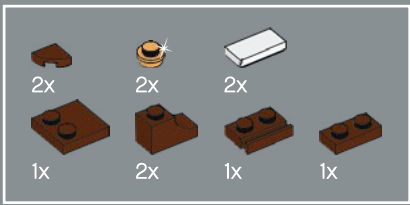

202

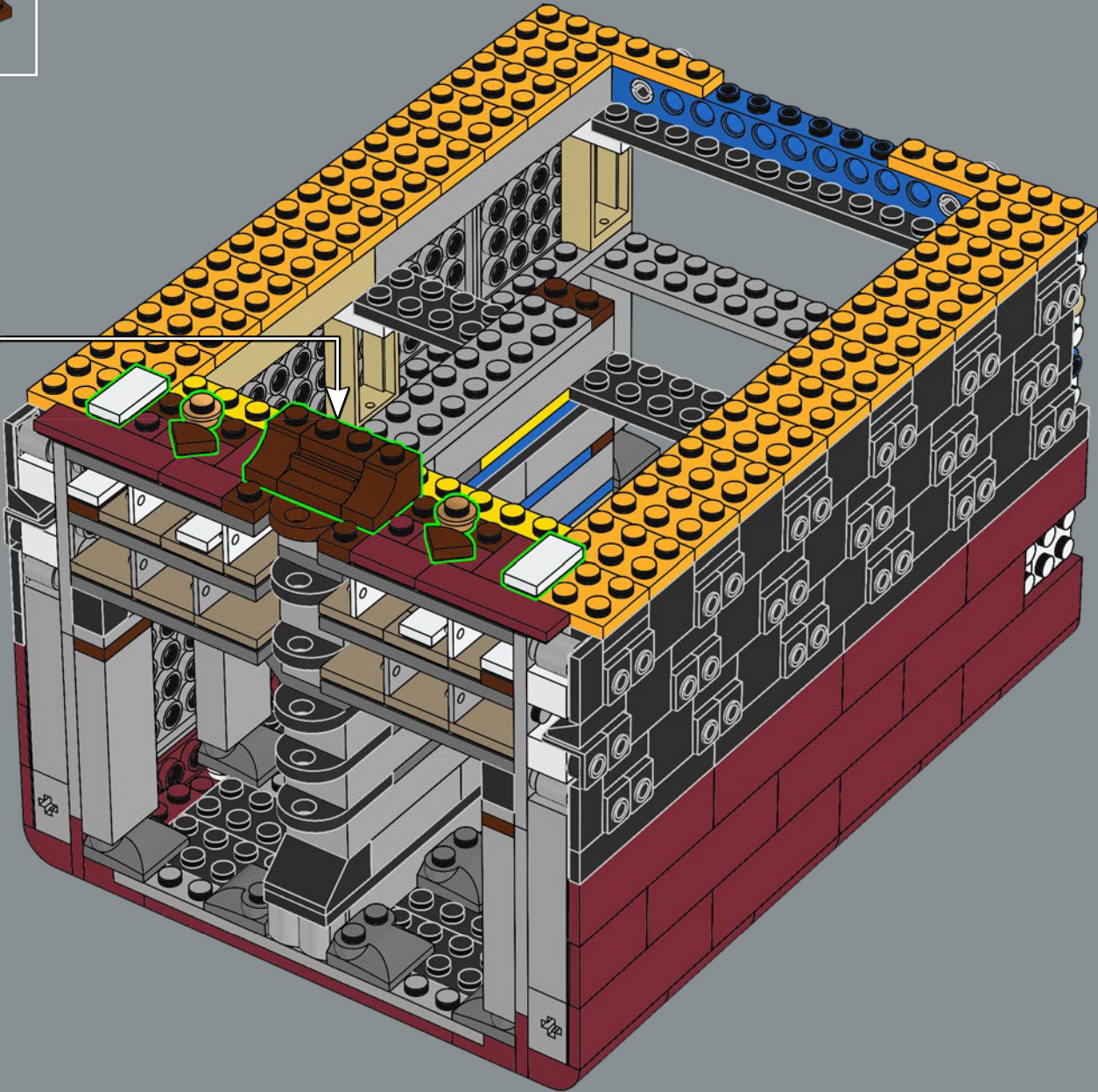
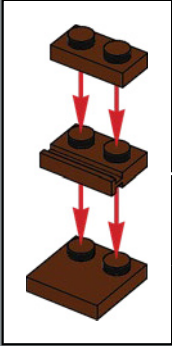

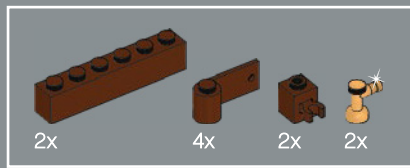

203

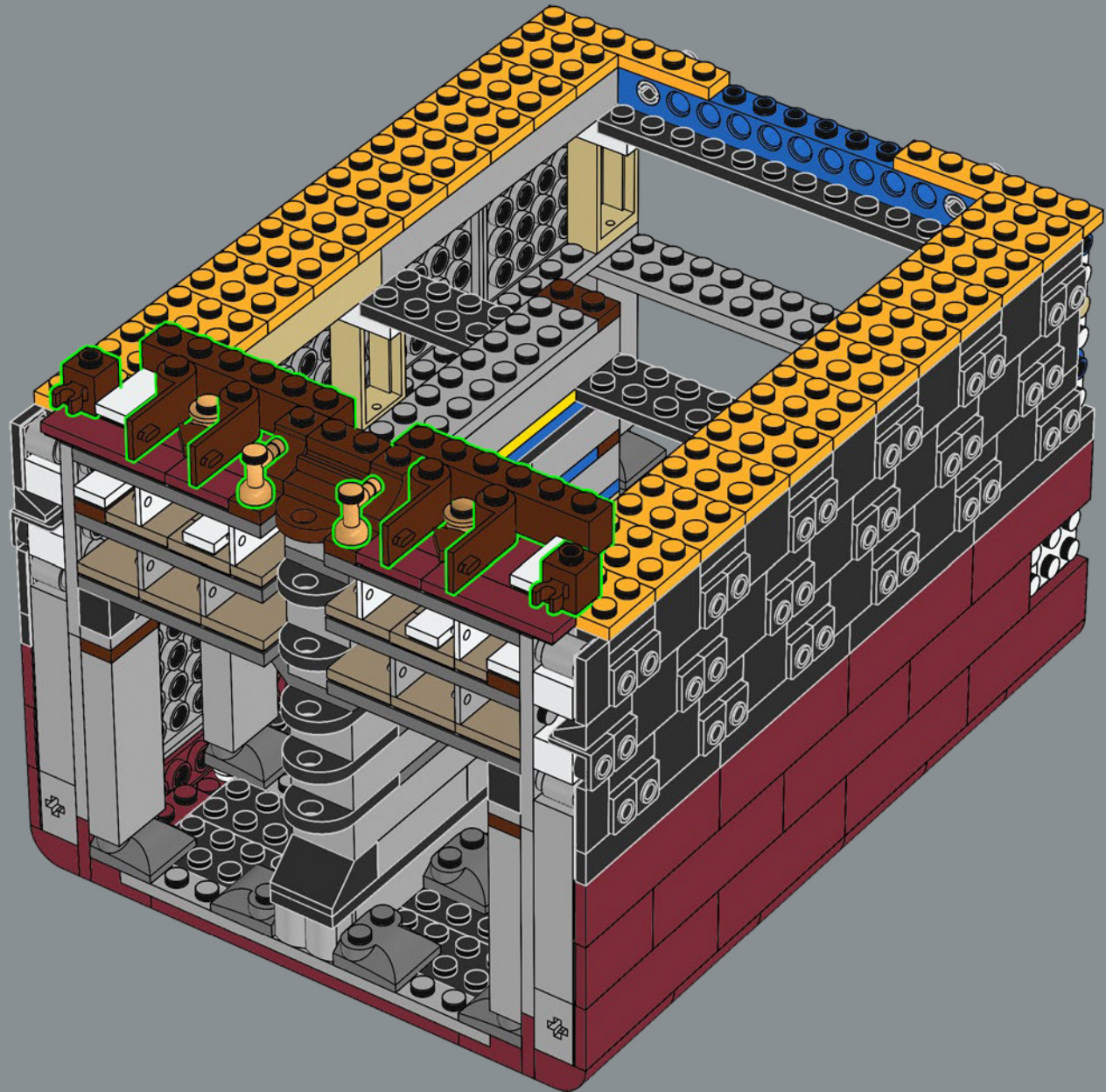

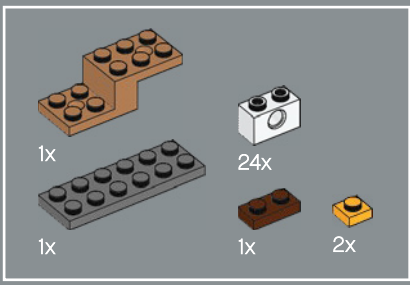

204

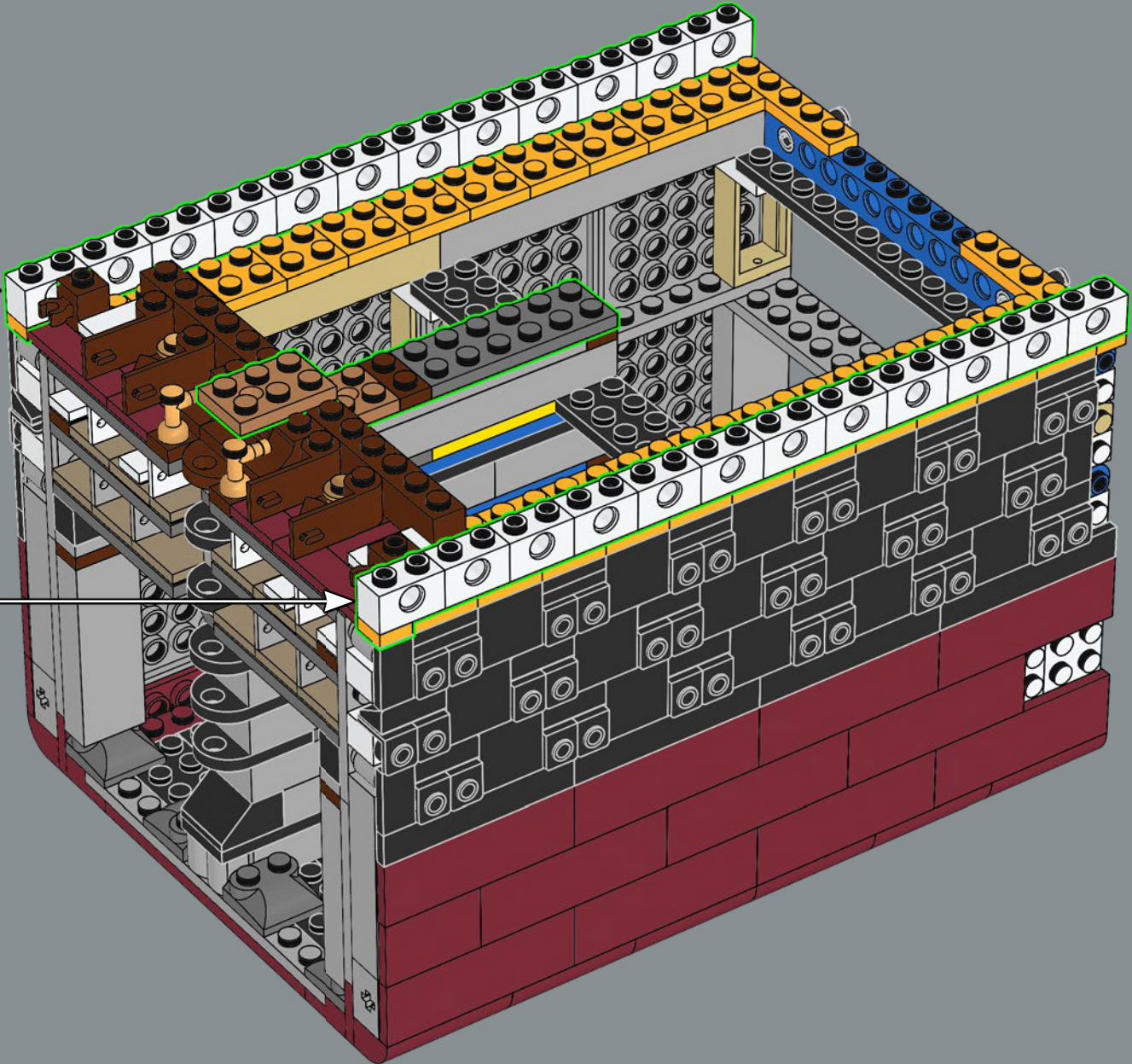
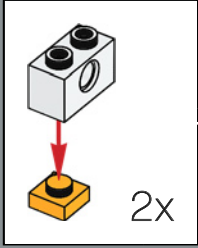

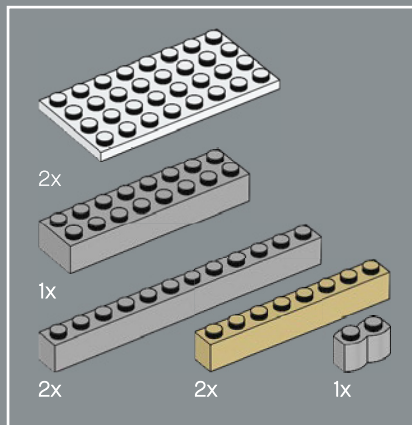

205

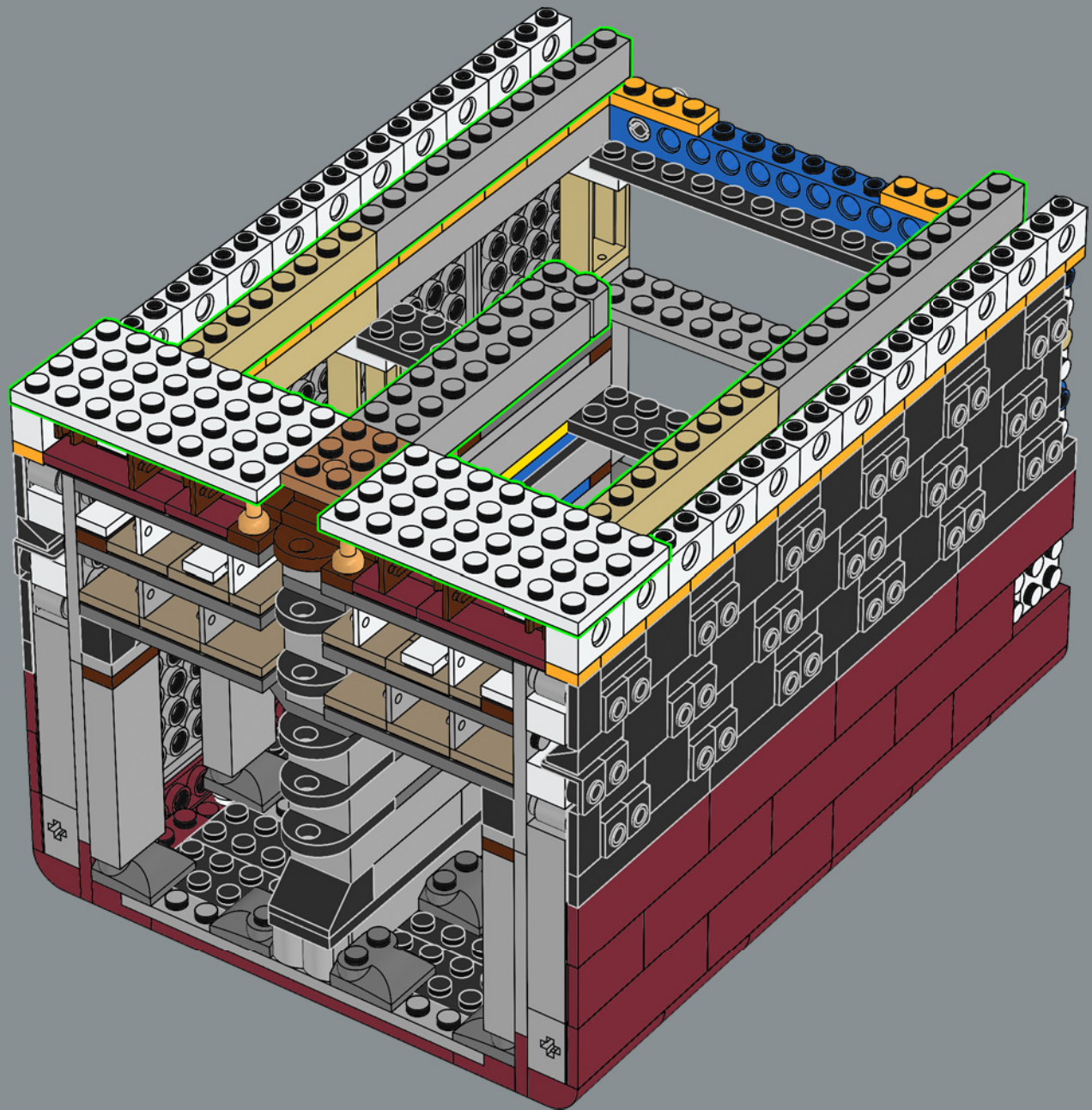

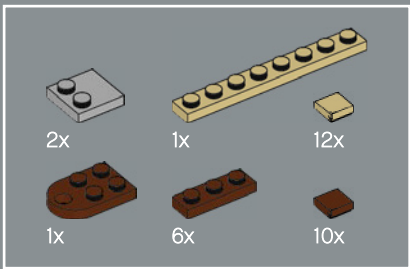

206

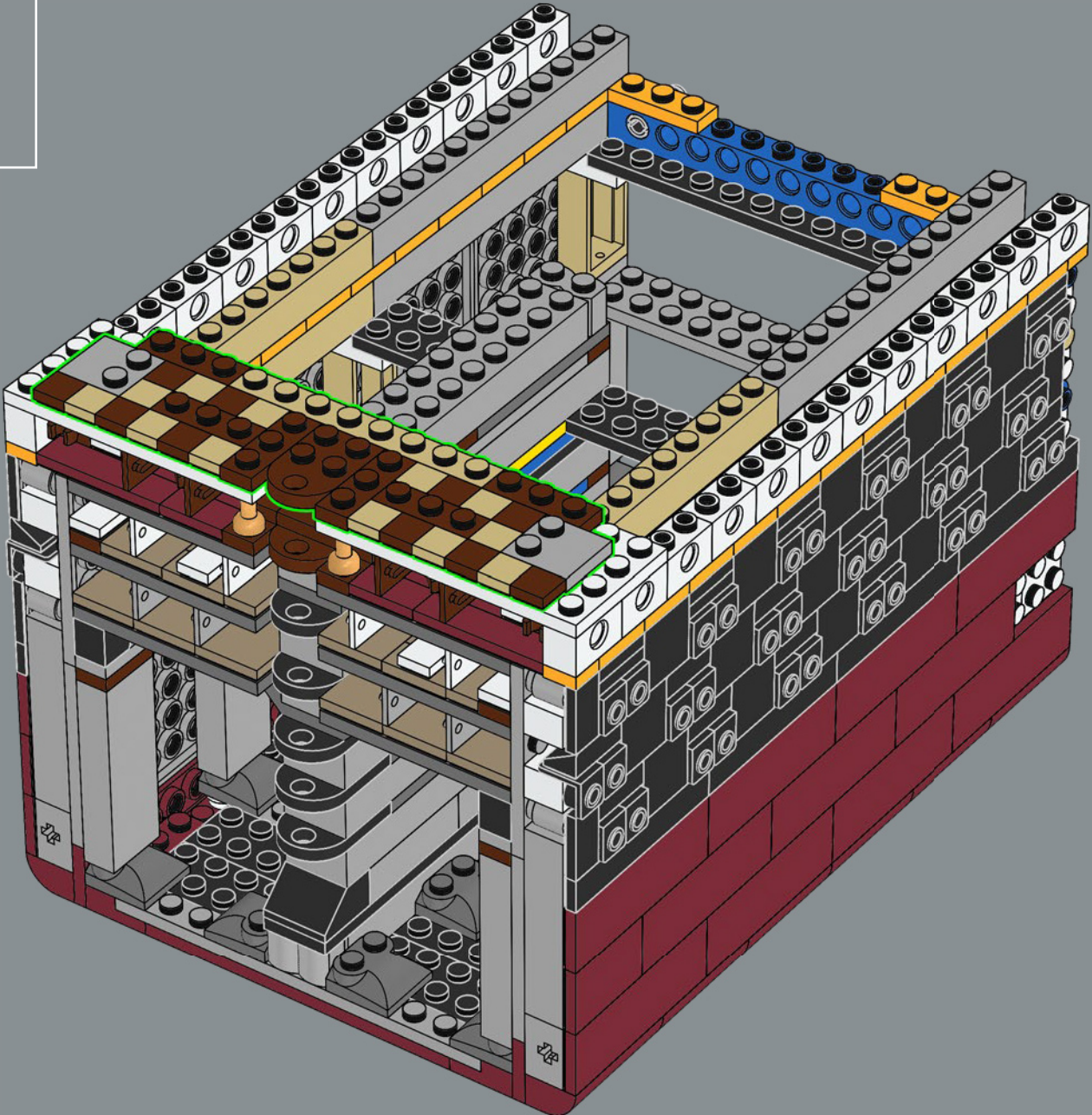

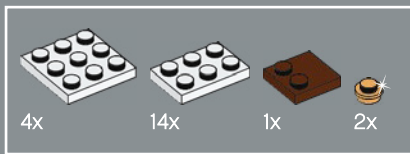

207

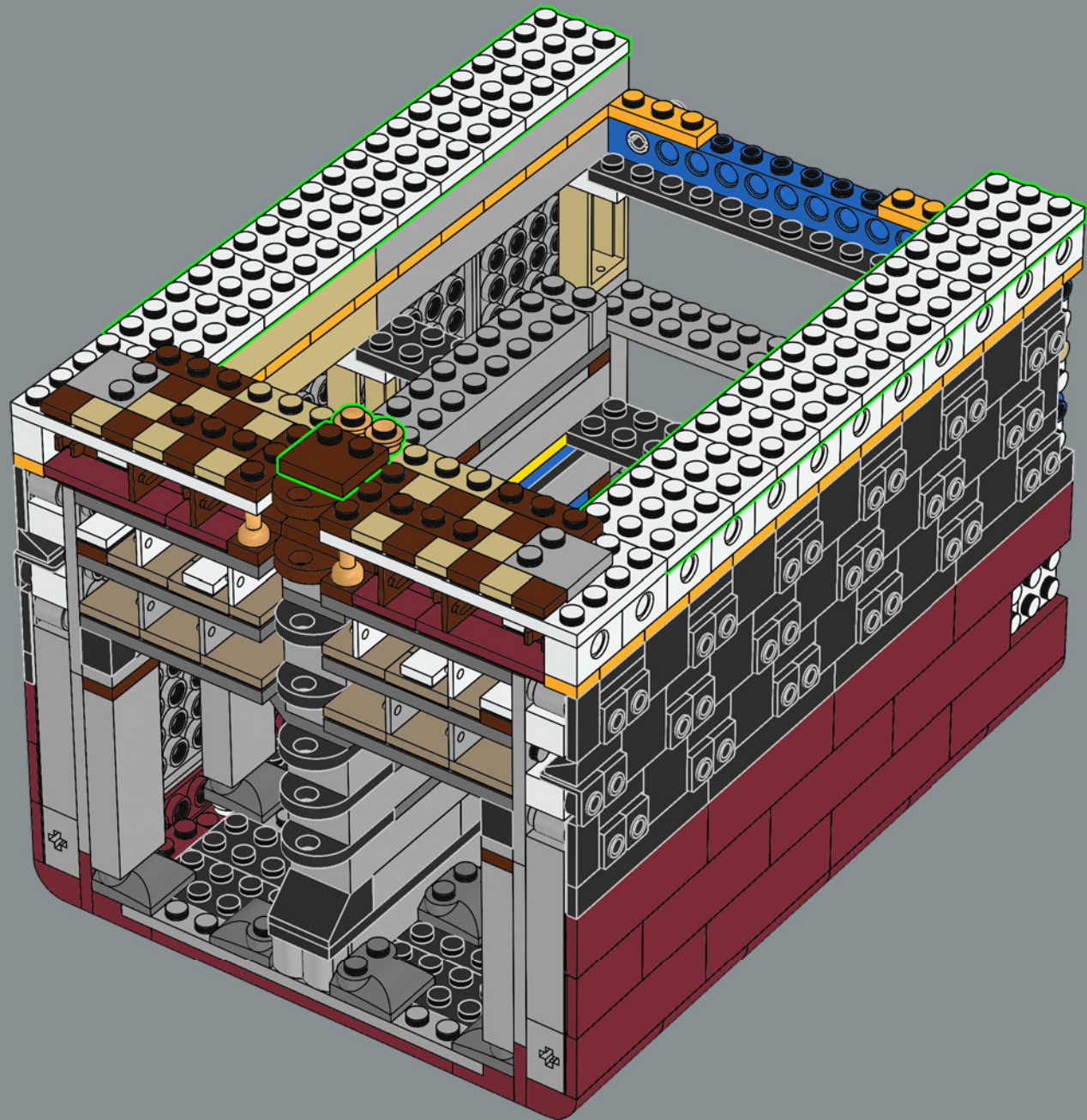

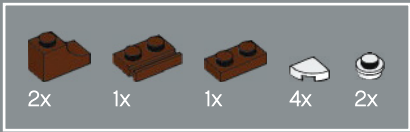

208

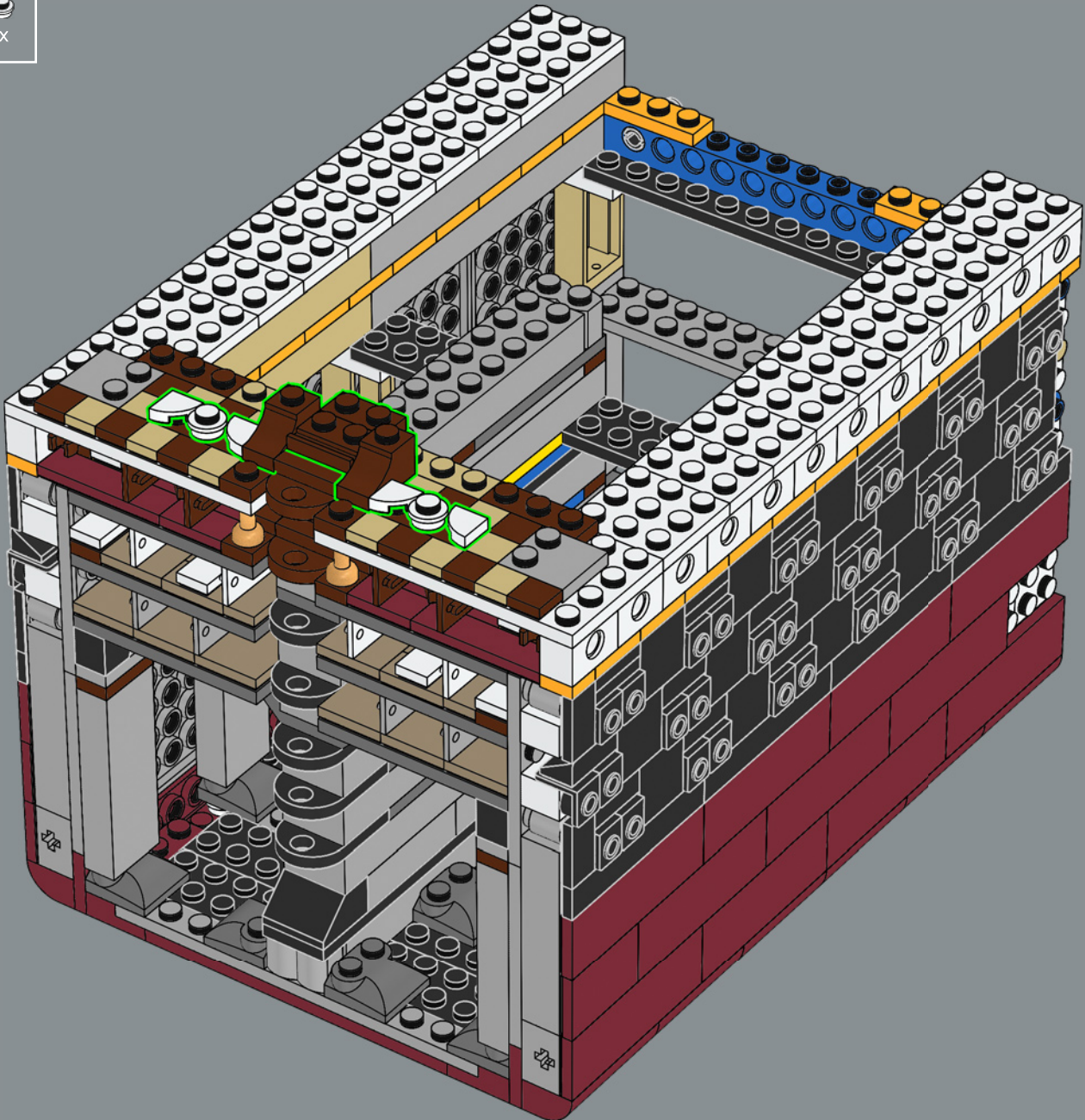

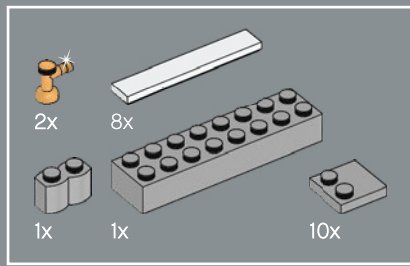

209

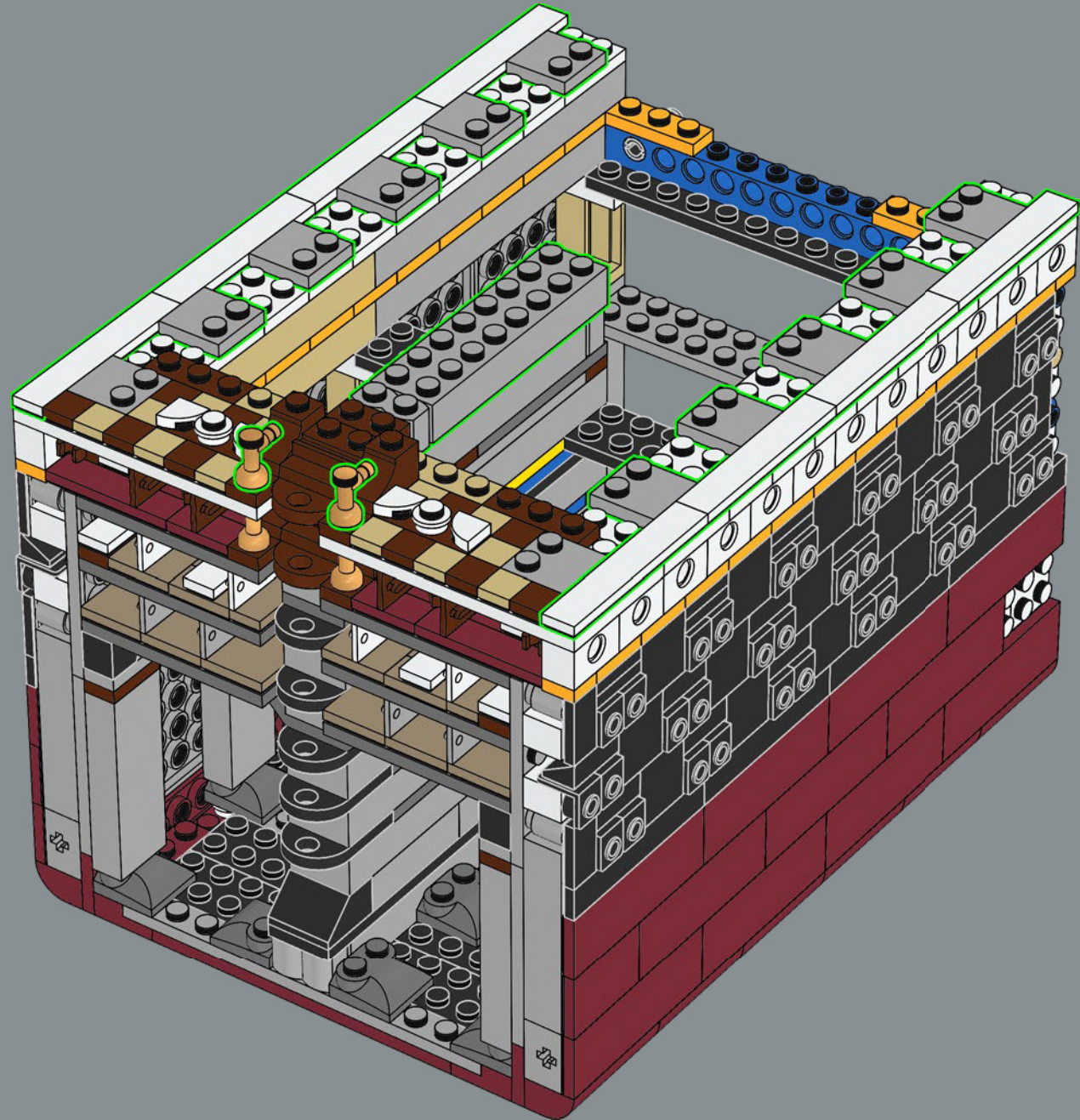

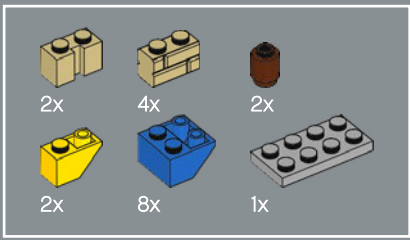

210

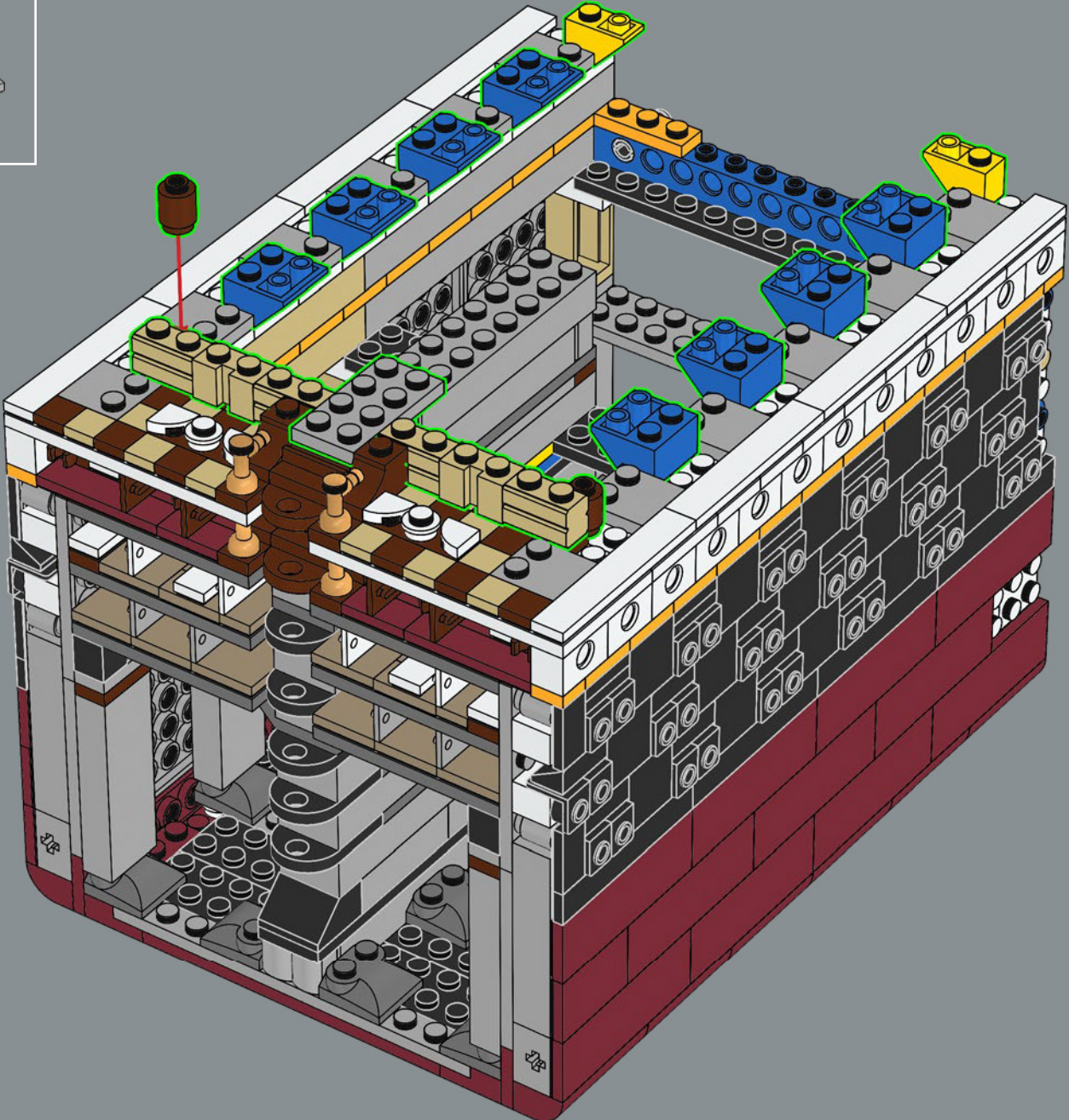

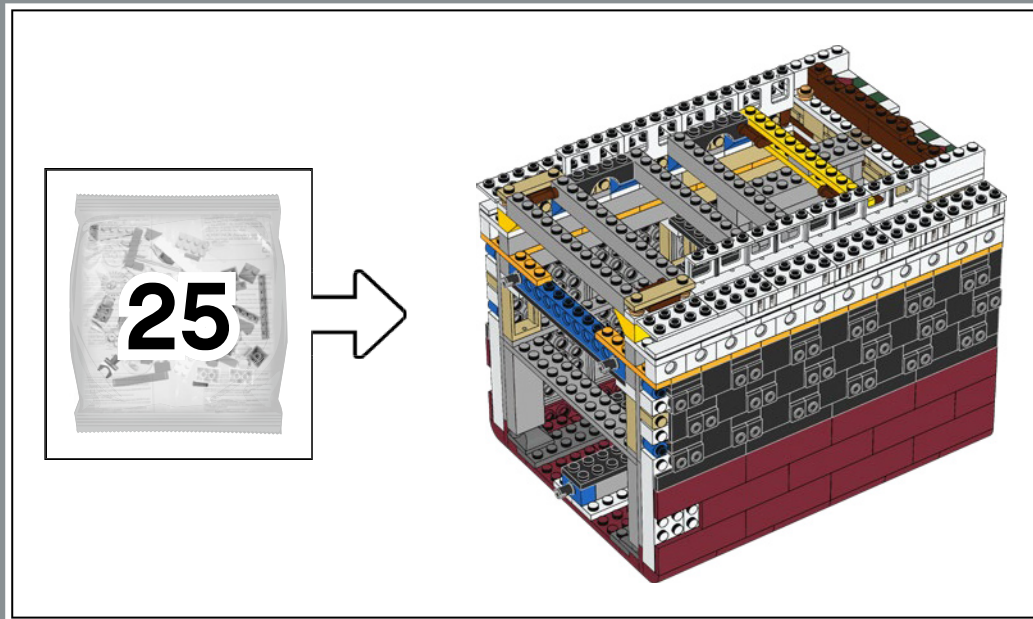



211

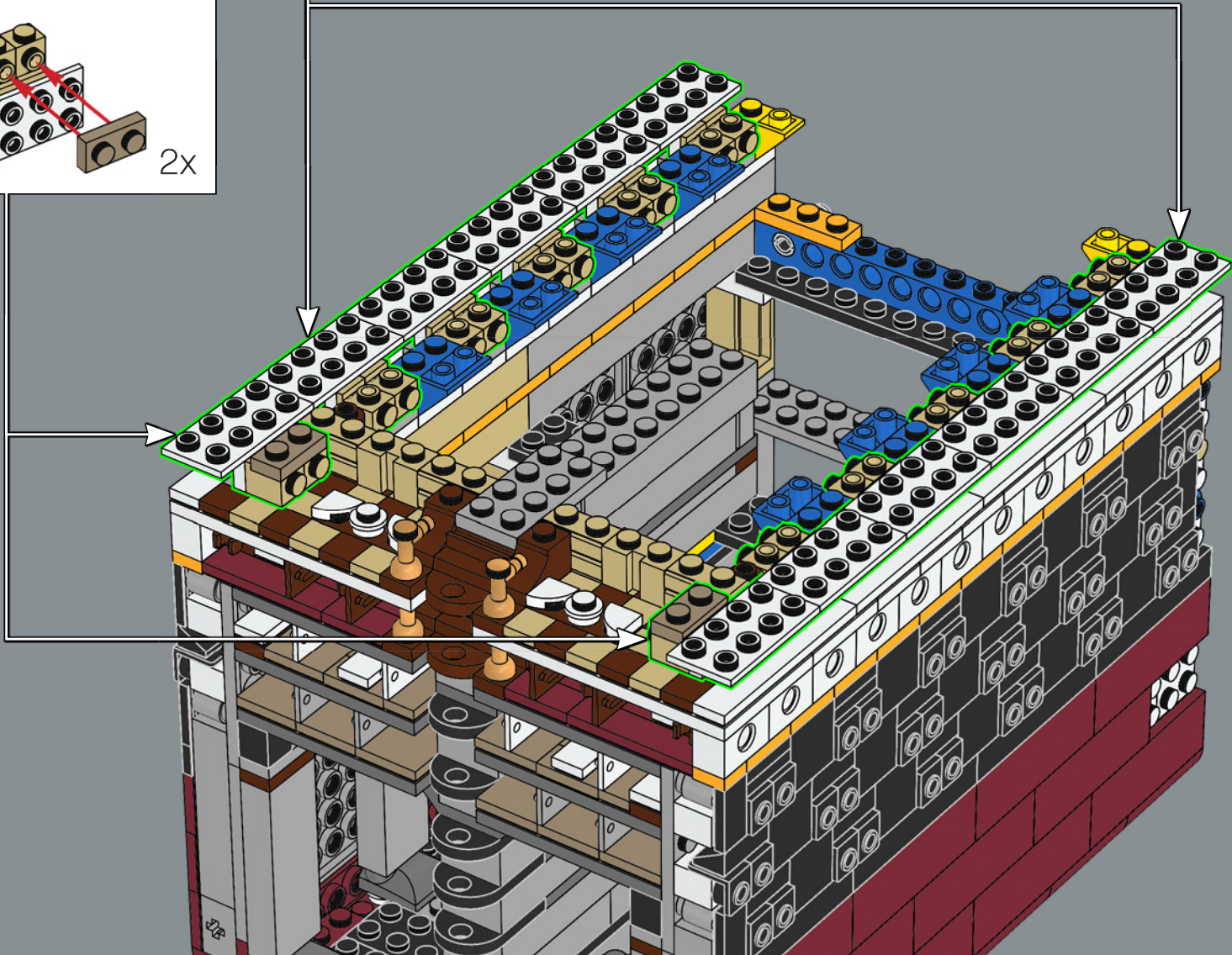
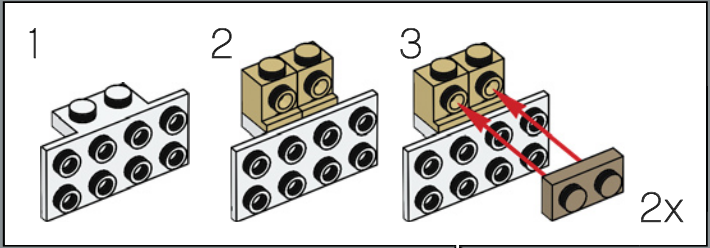
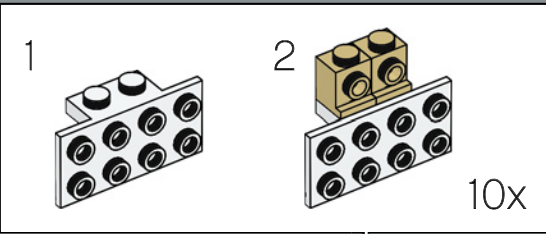

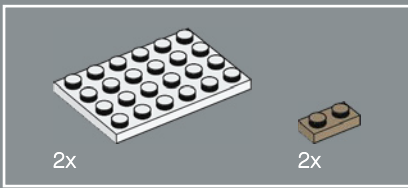

212

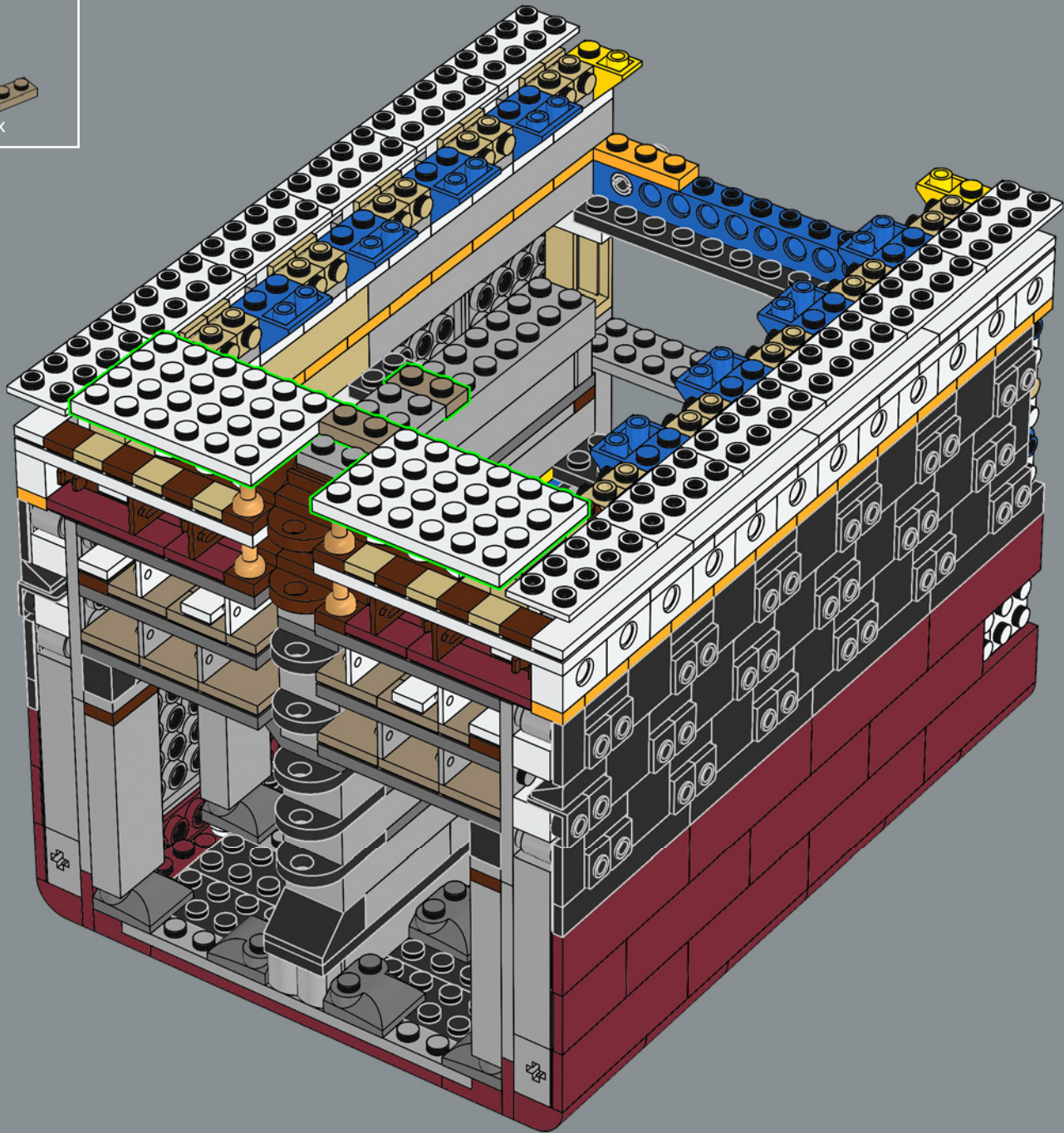

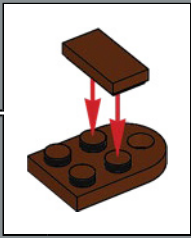
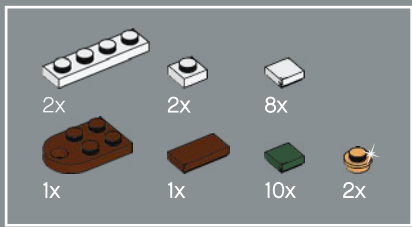

213

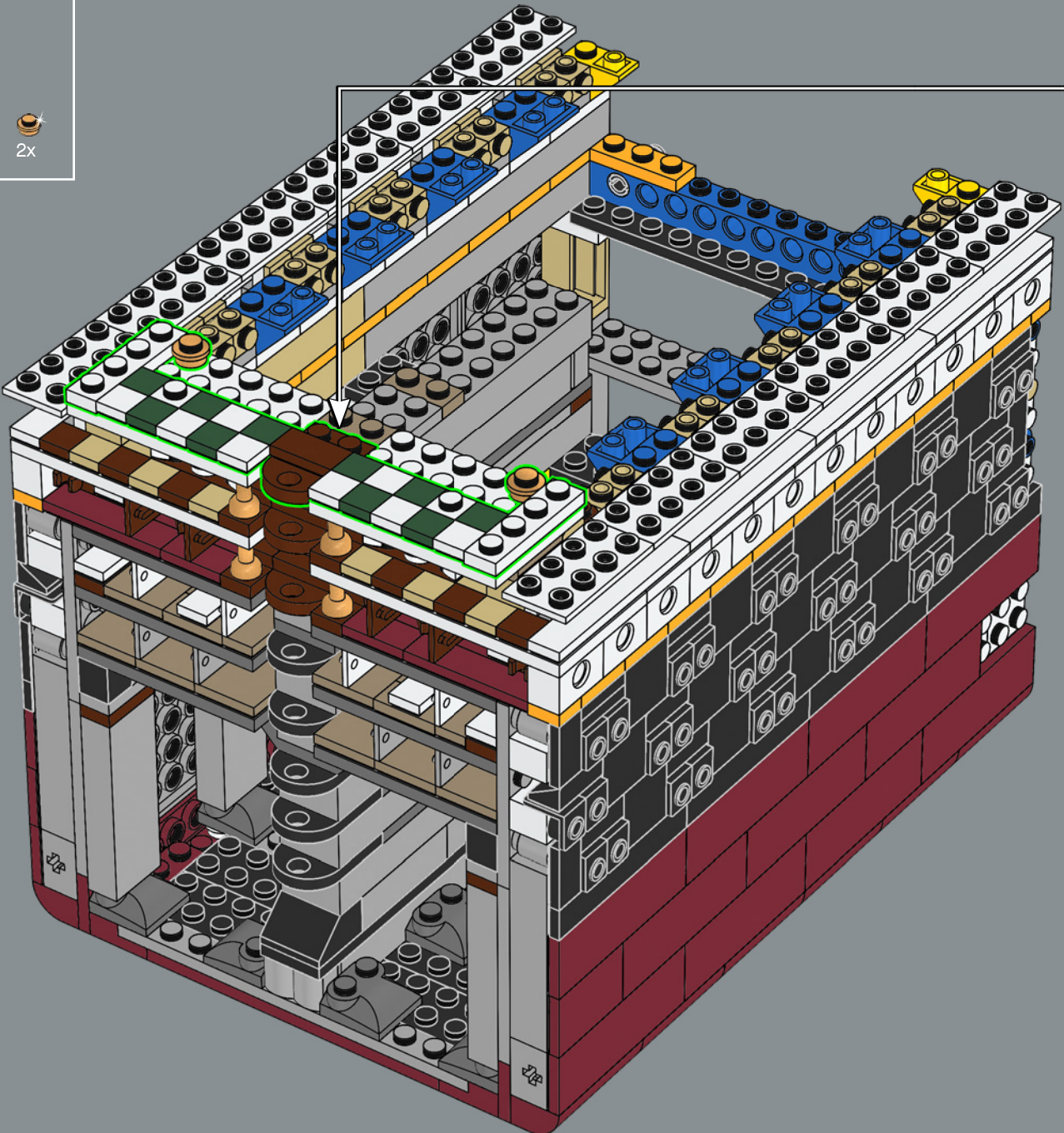

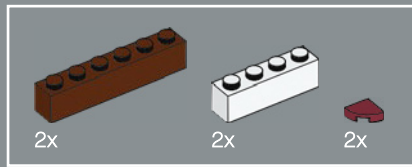

214

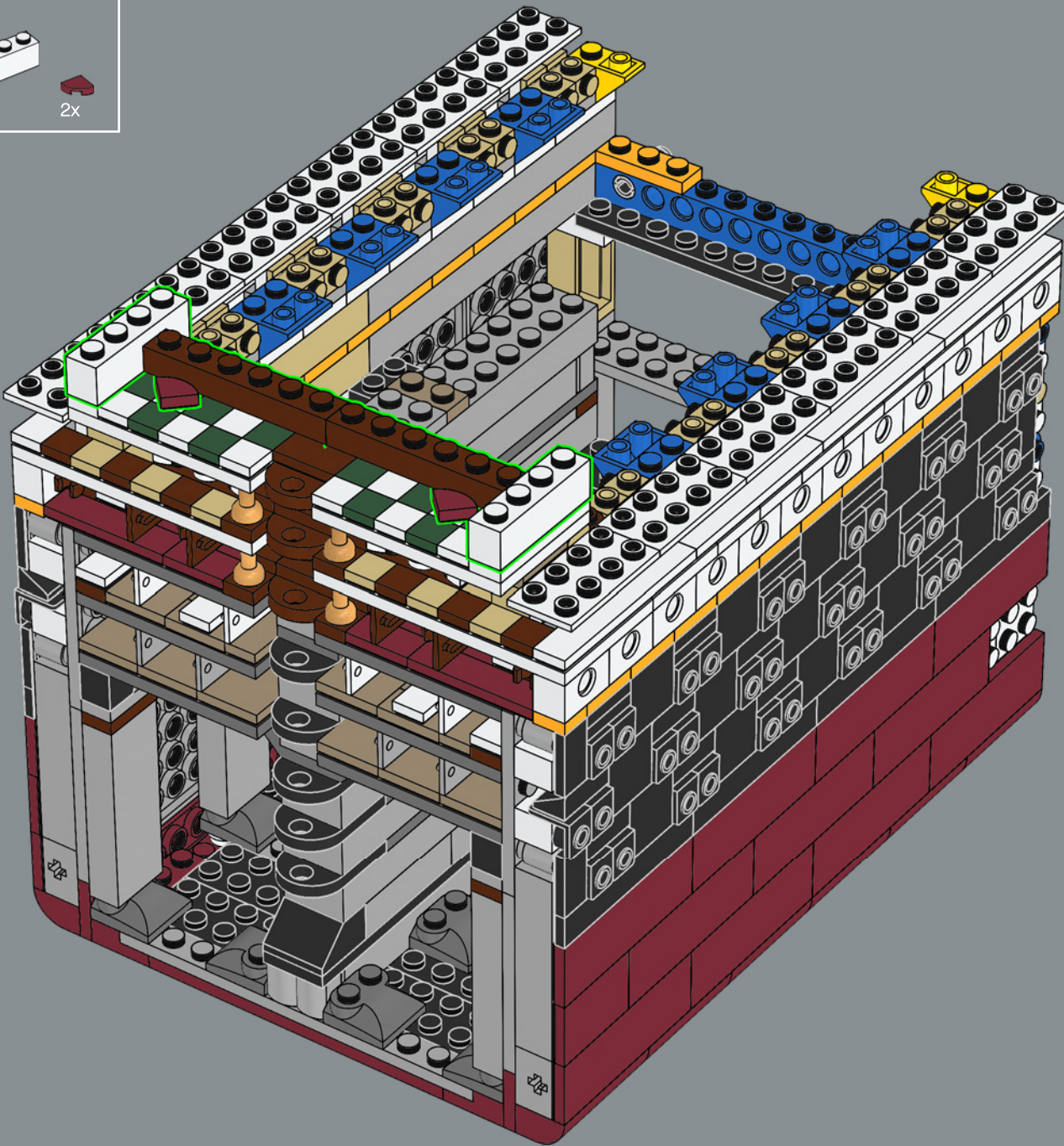

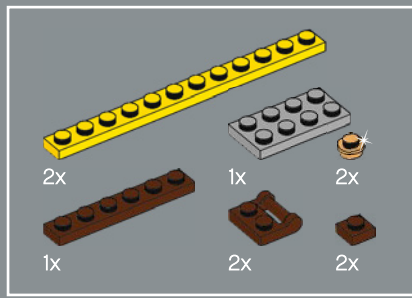

216

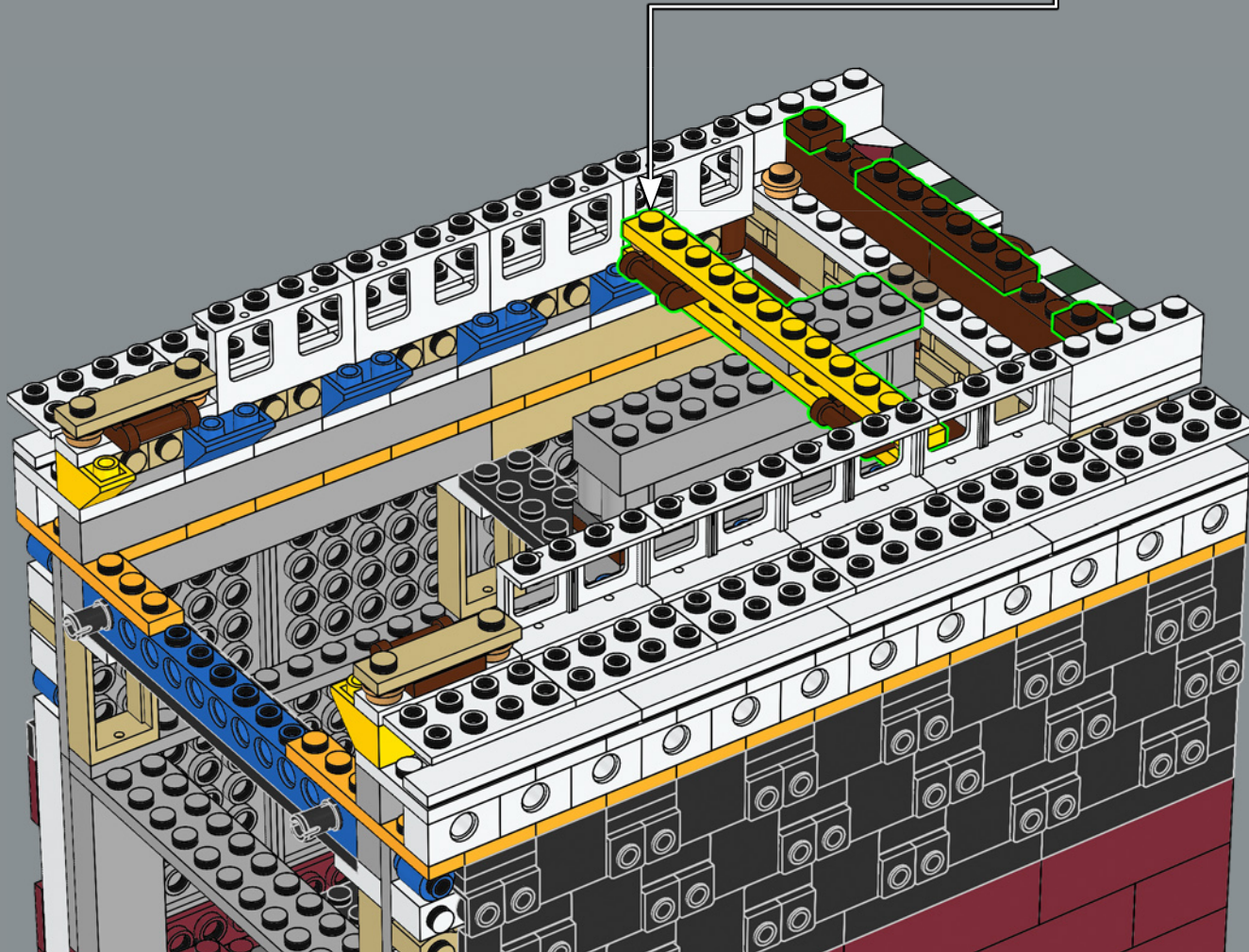
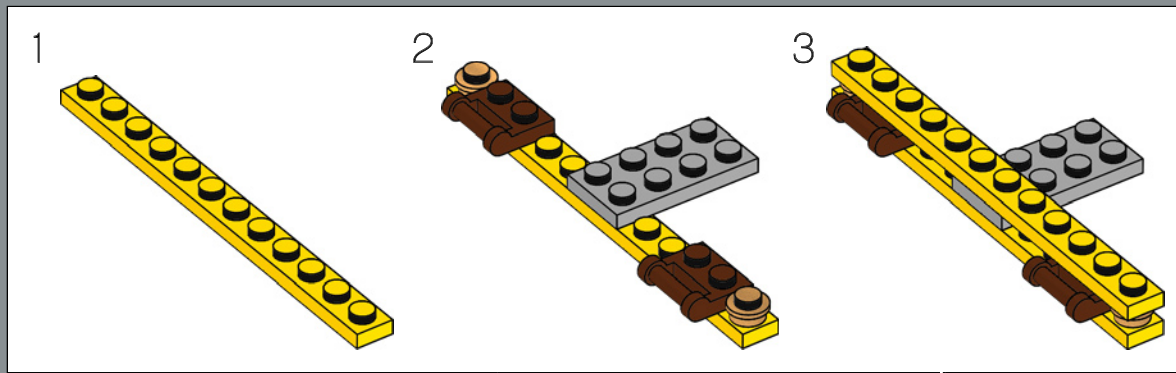

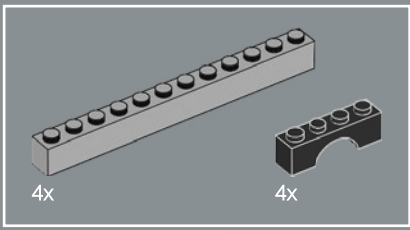

217

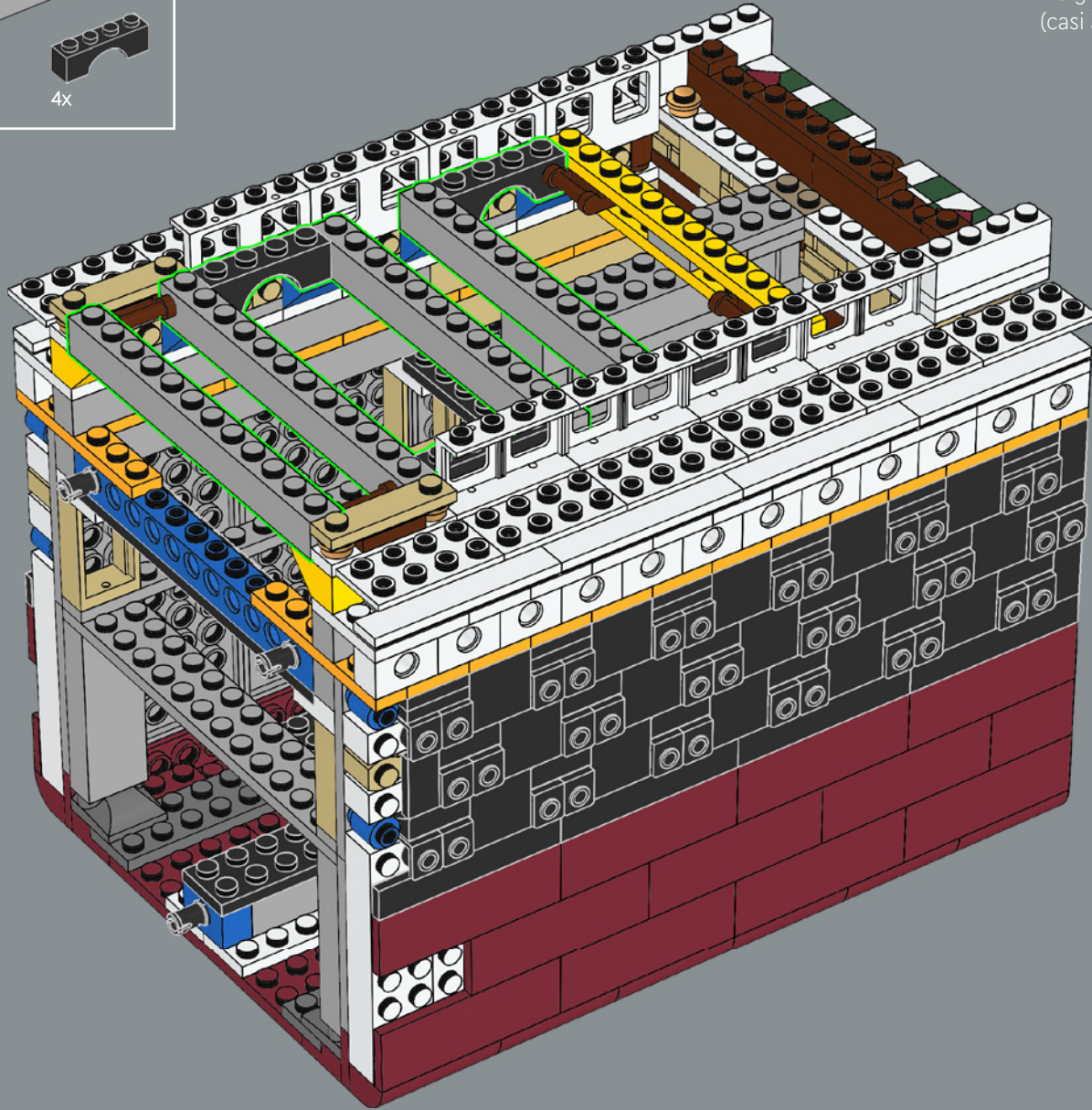

La construcción de los buques *Titanic* y *Olympic* costó 3 millones de libras esterlinas (casi 300 millones de libras esterlinas de hoy).

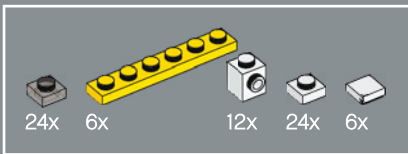

218

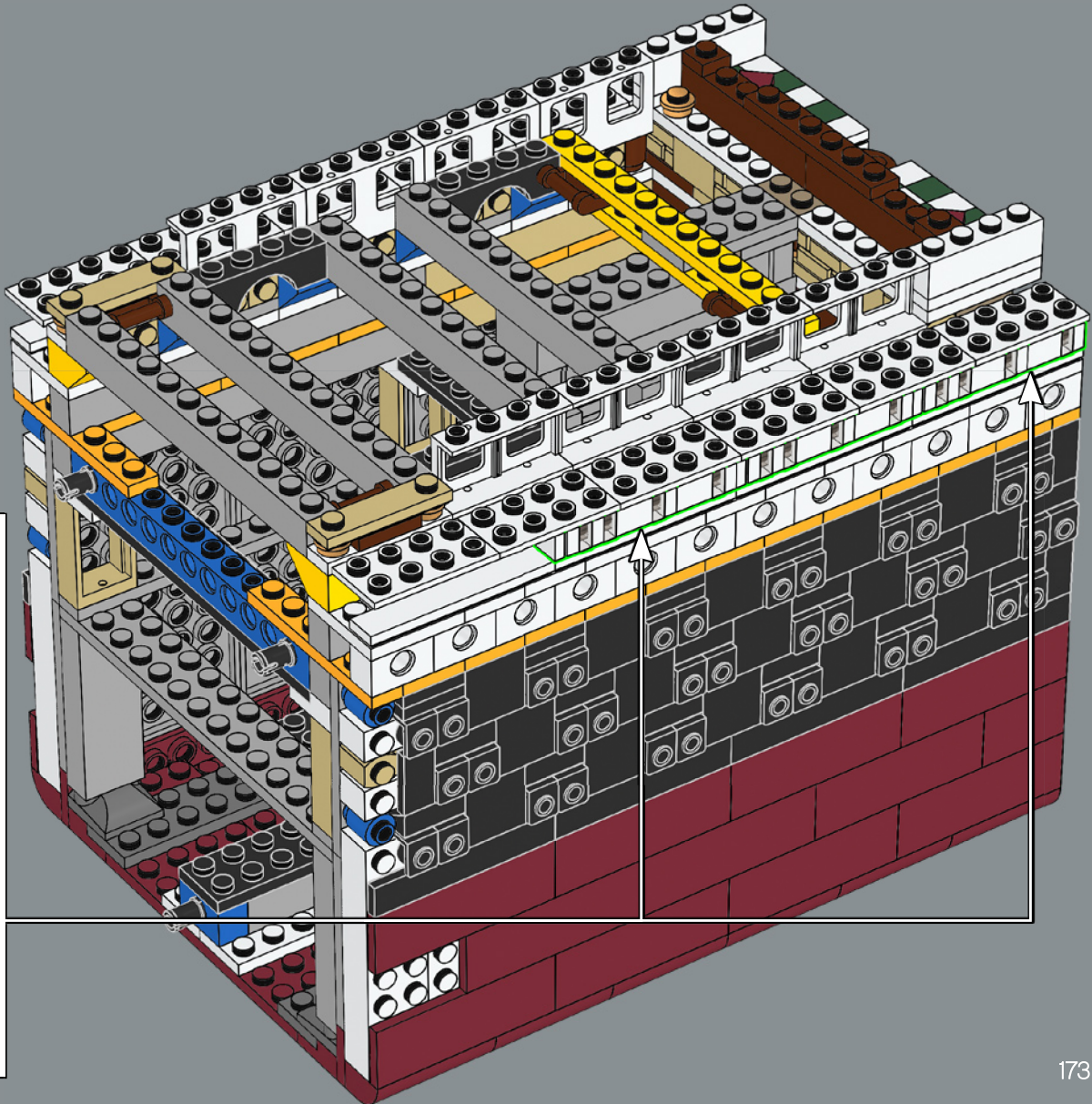
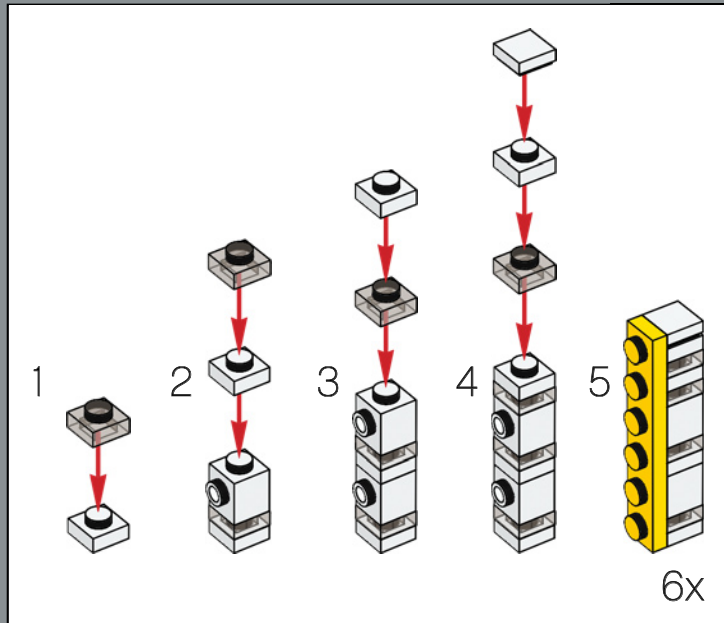

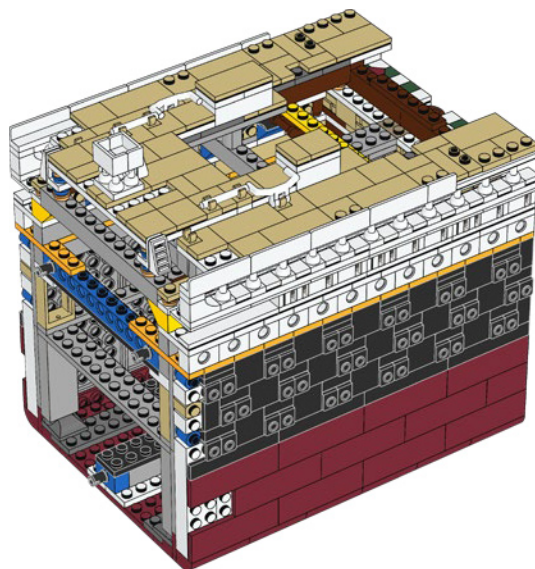
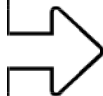

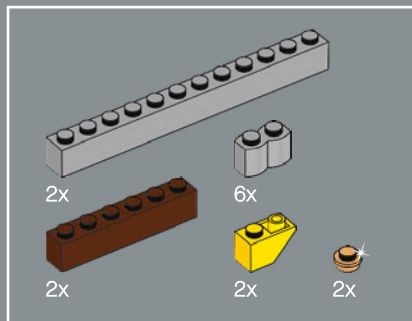

219

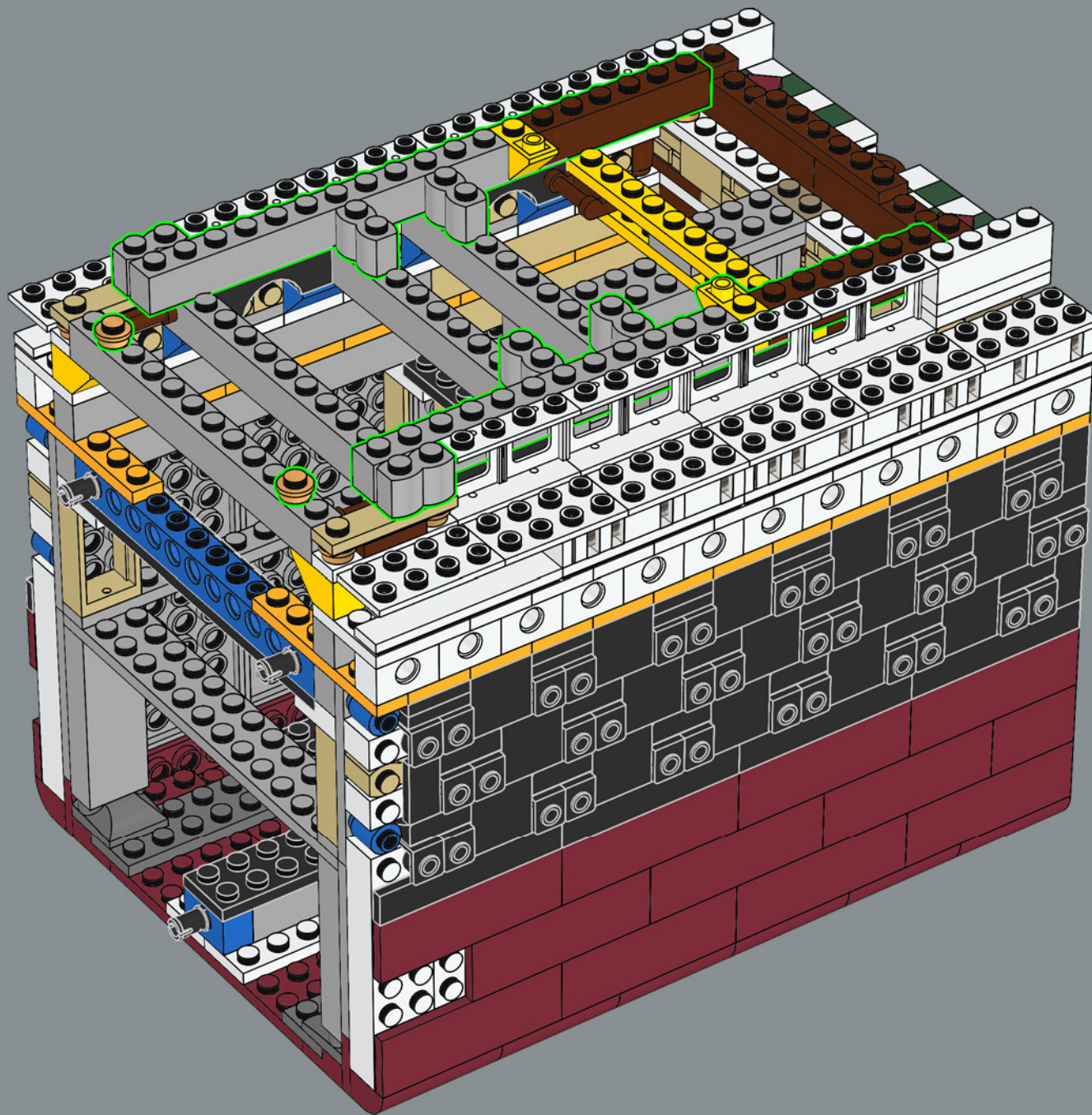

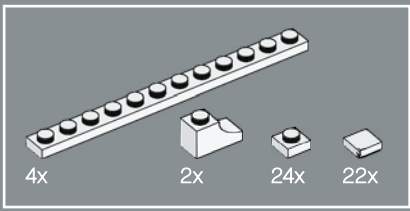

220

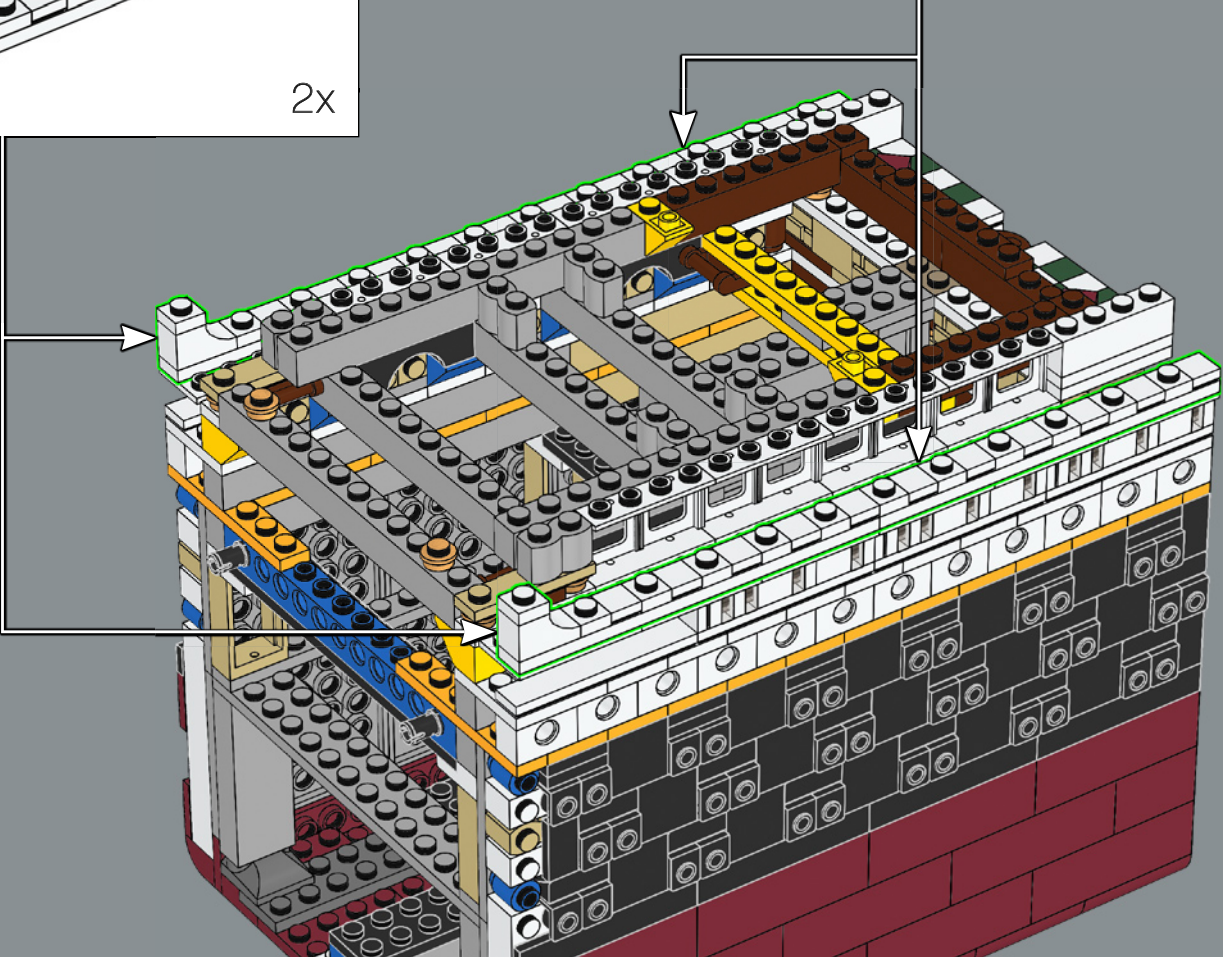
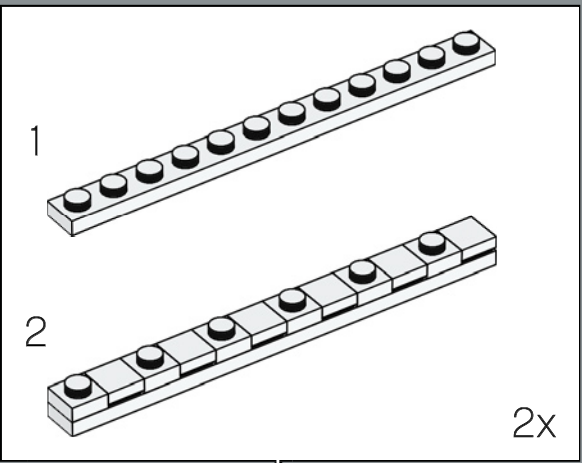
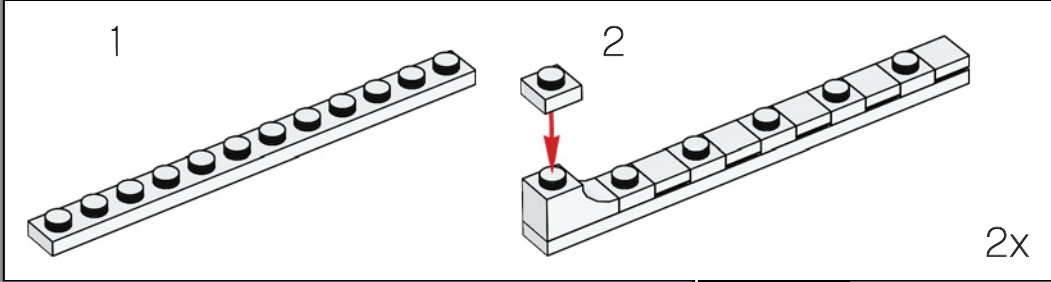

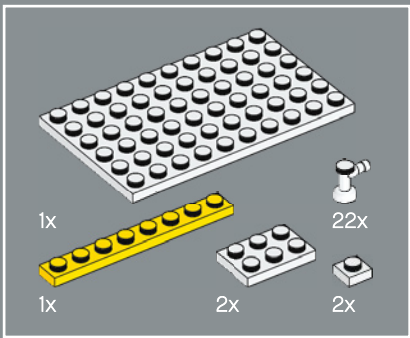

222

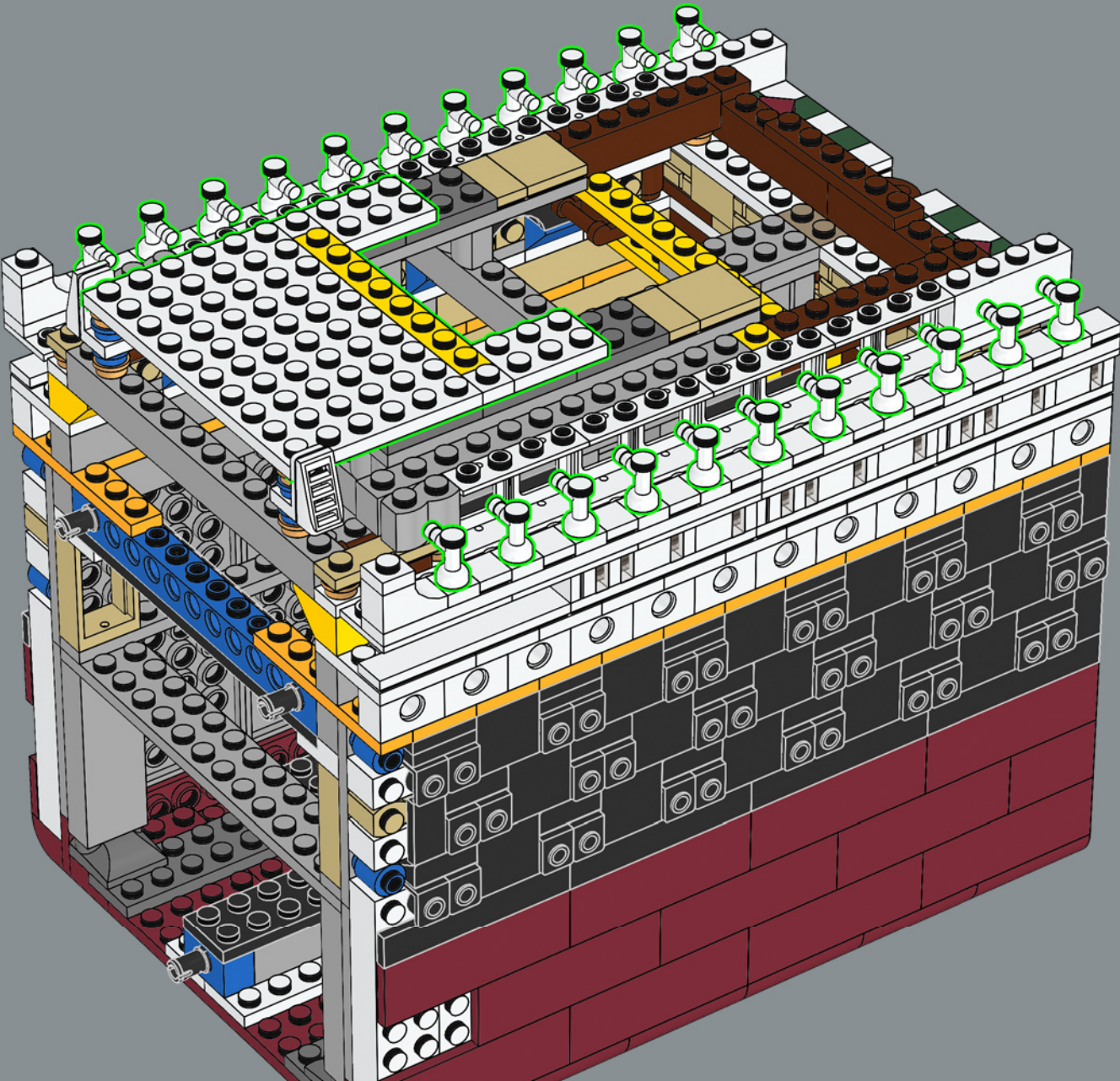

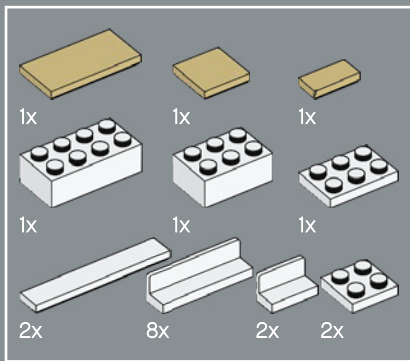

223

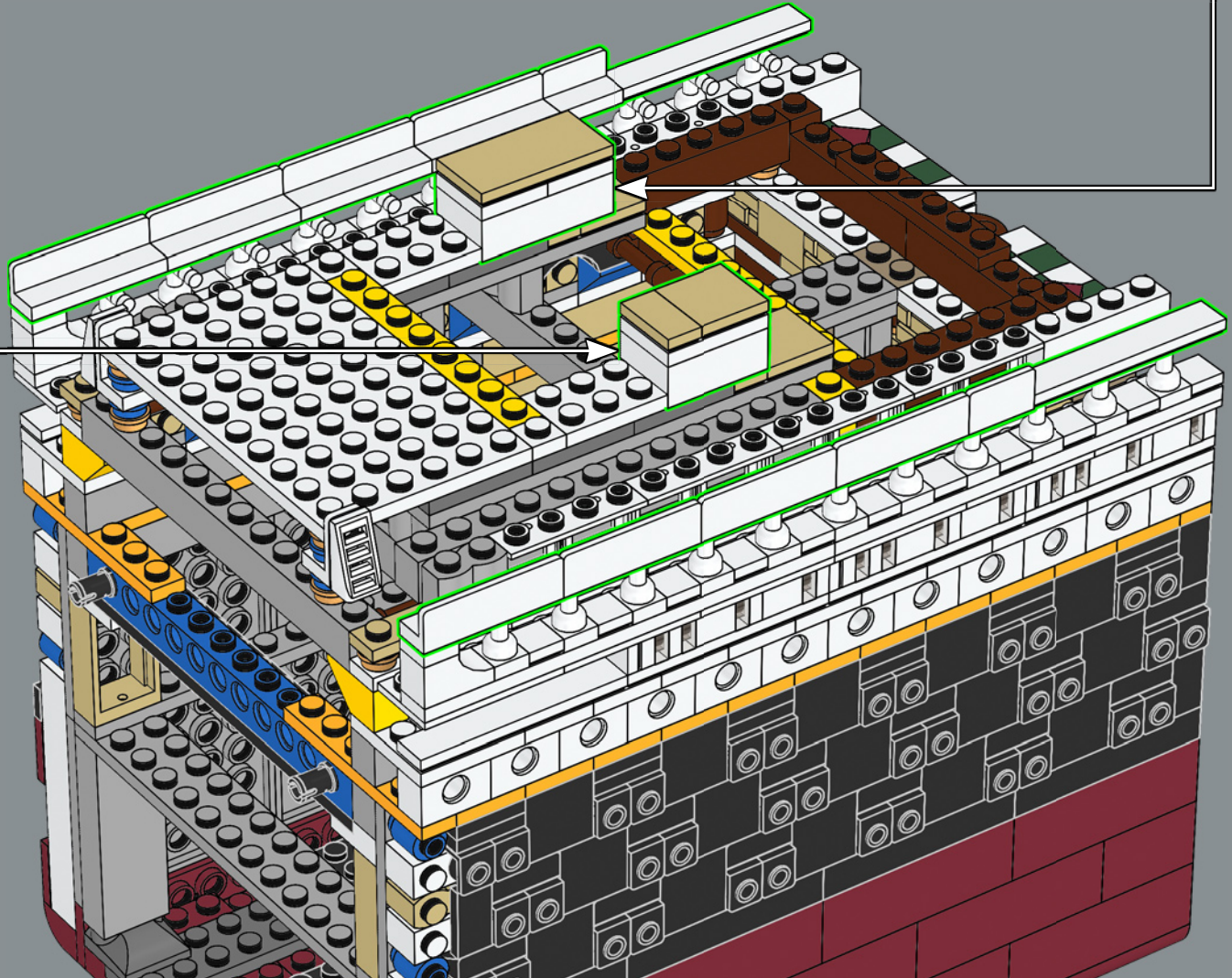
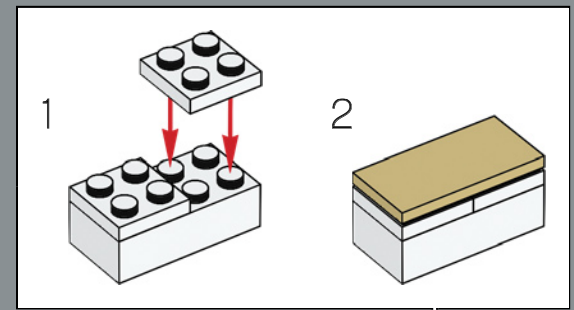
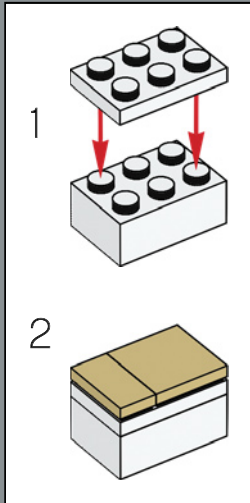

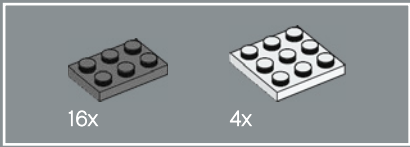

224

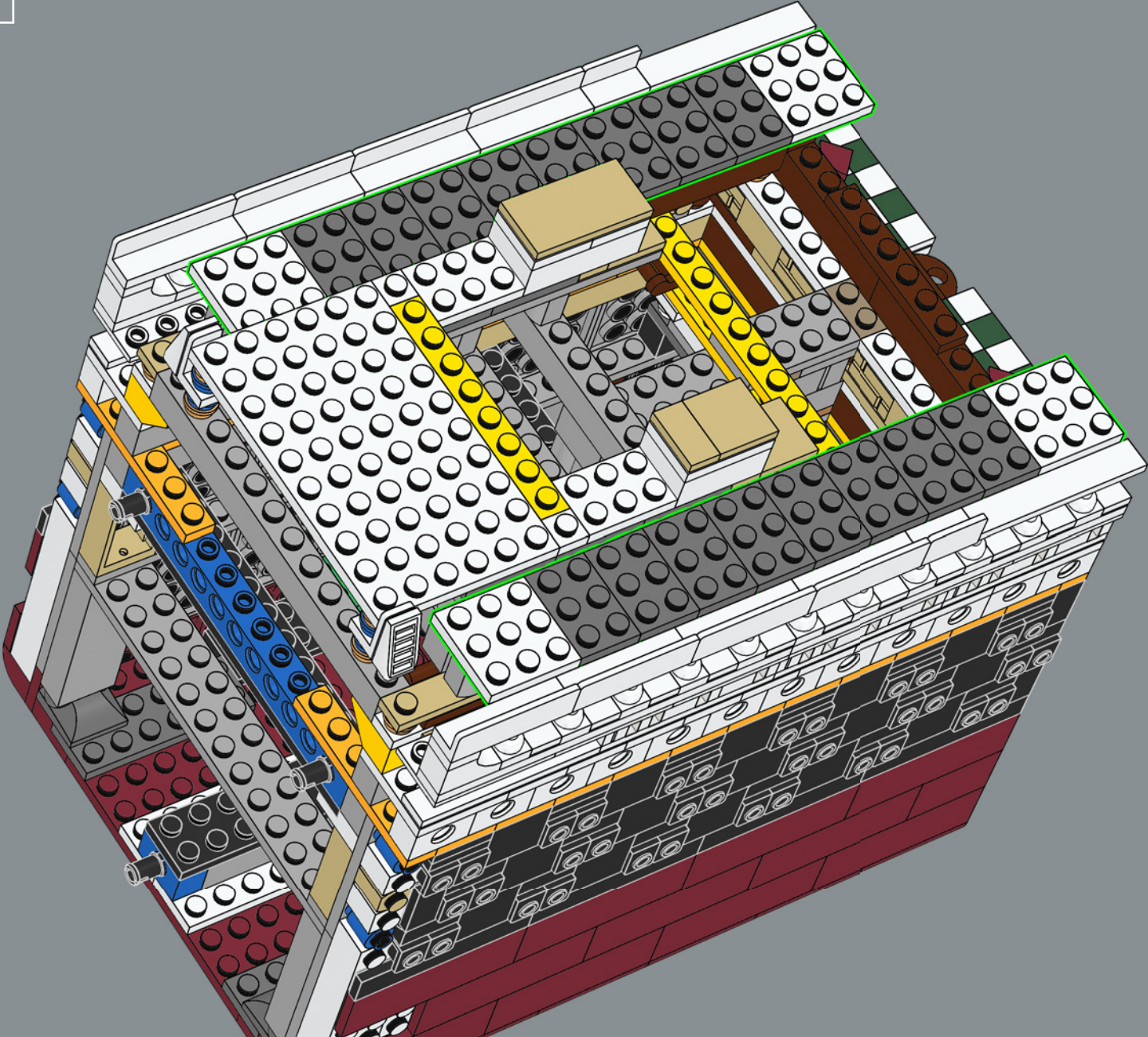

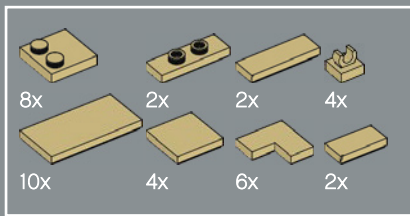

225

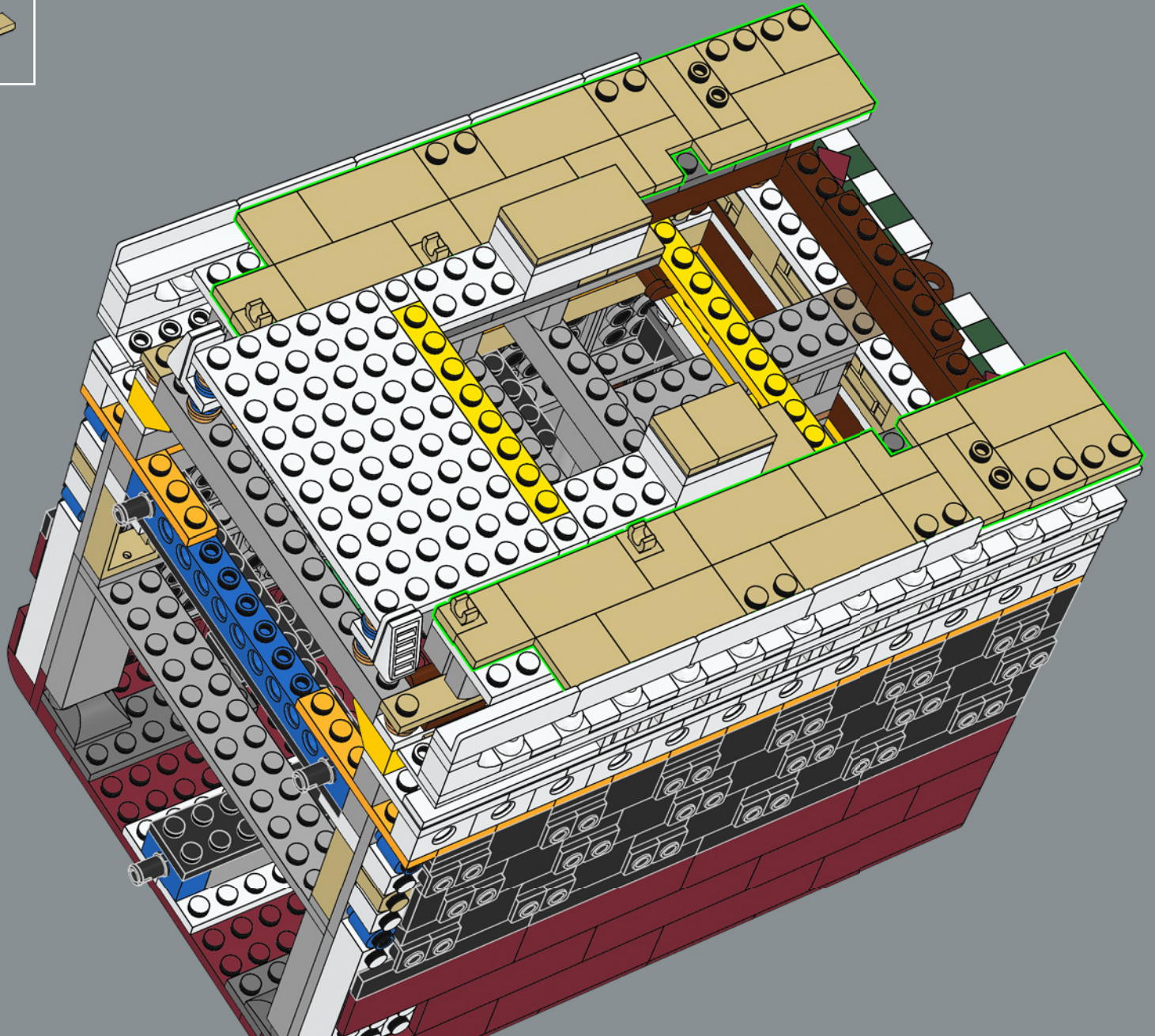

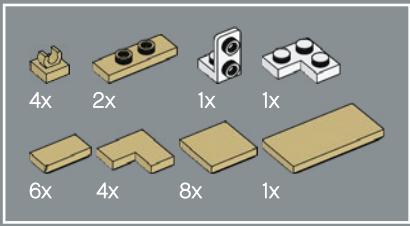

226

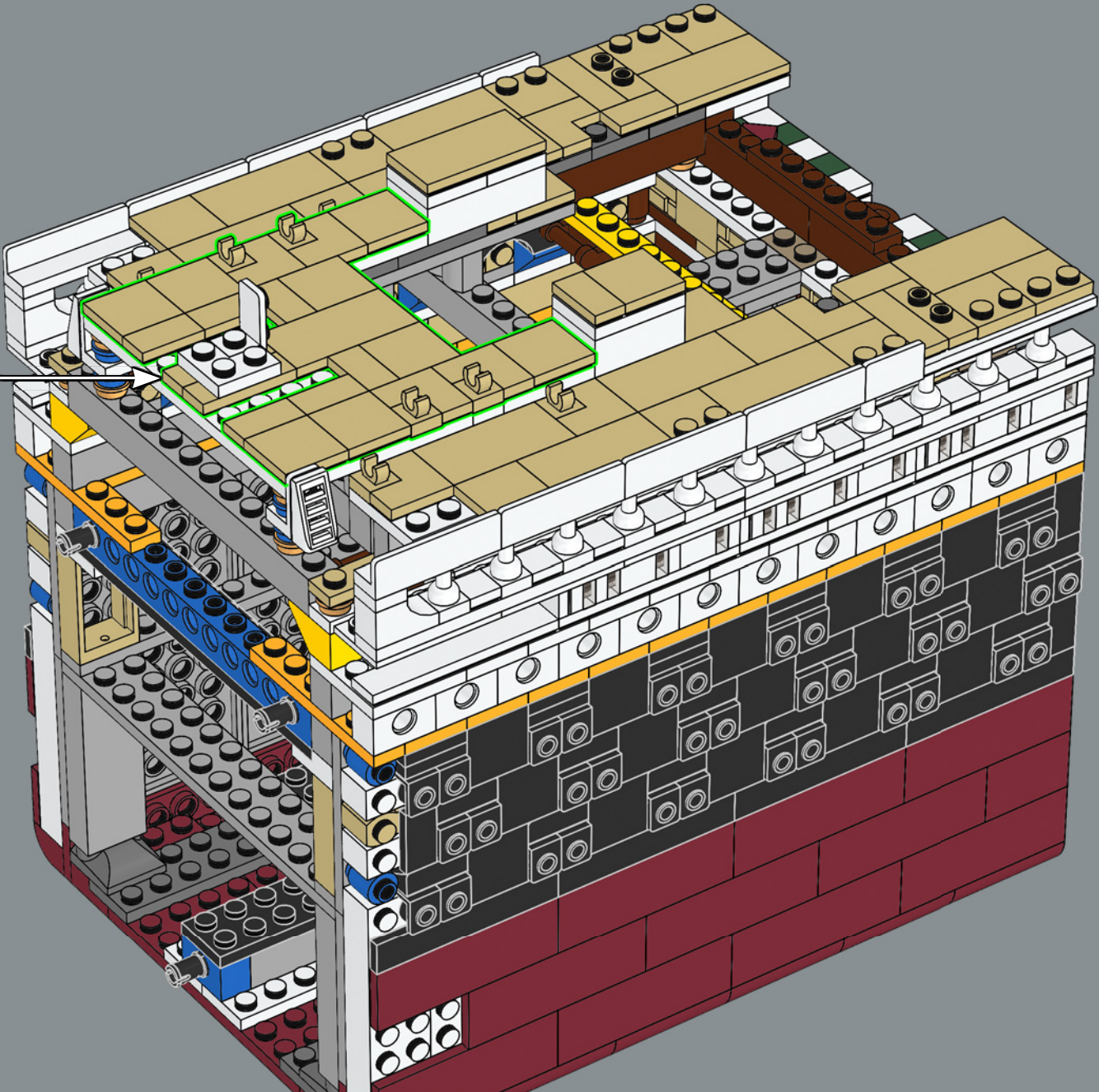
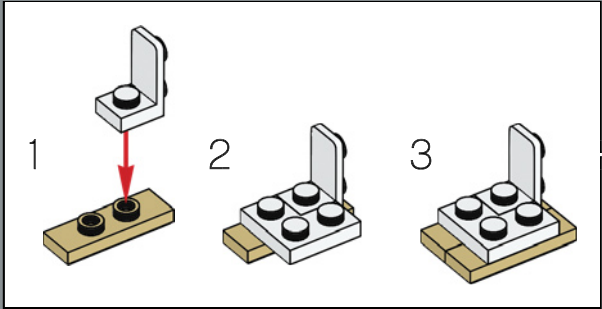



227

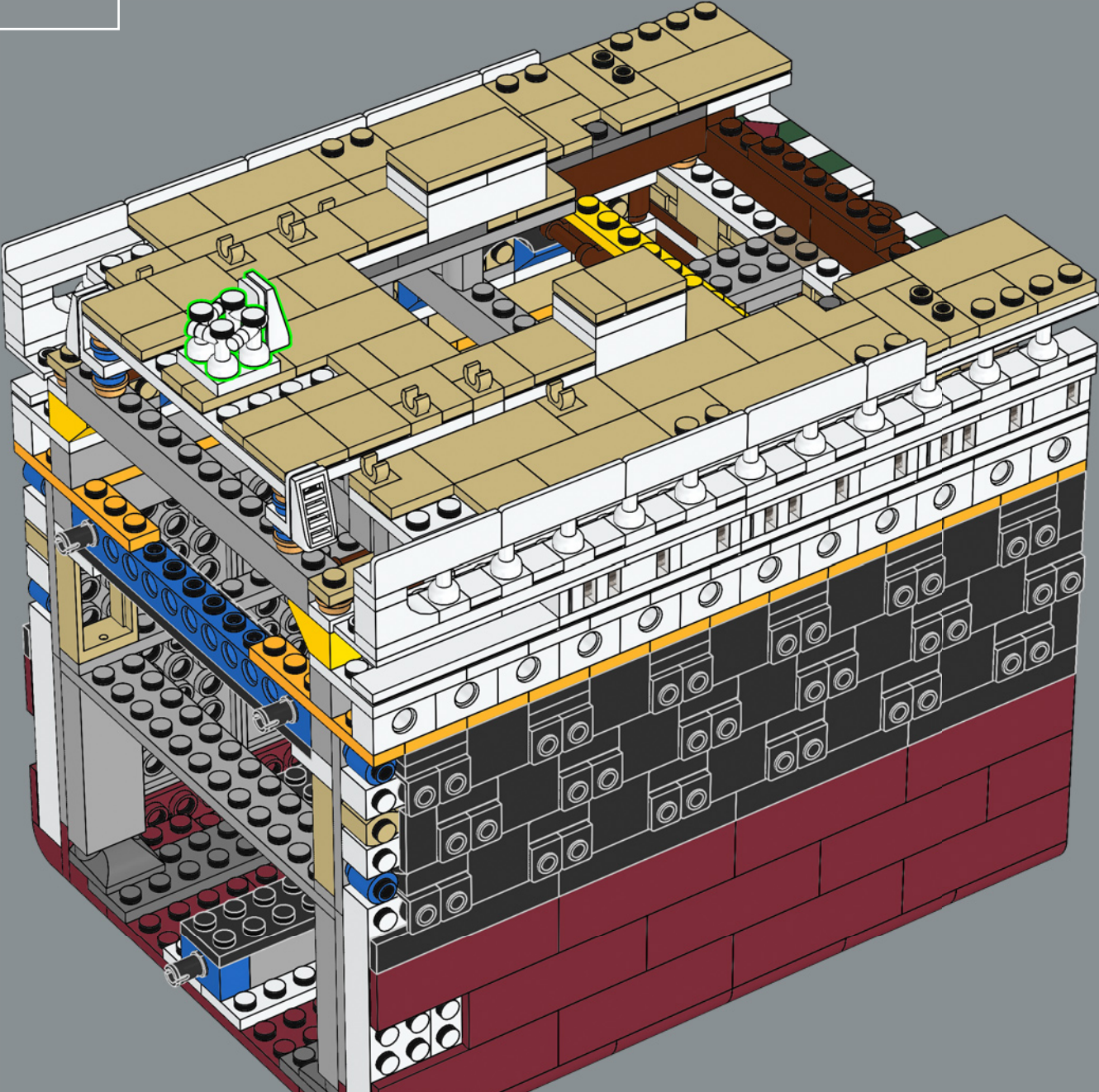

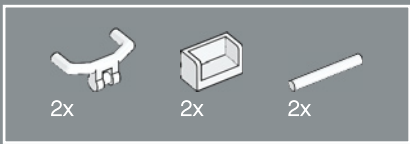

228

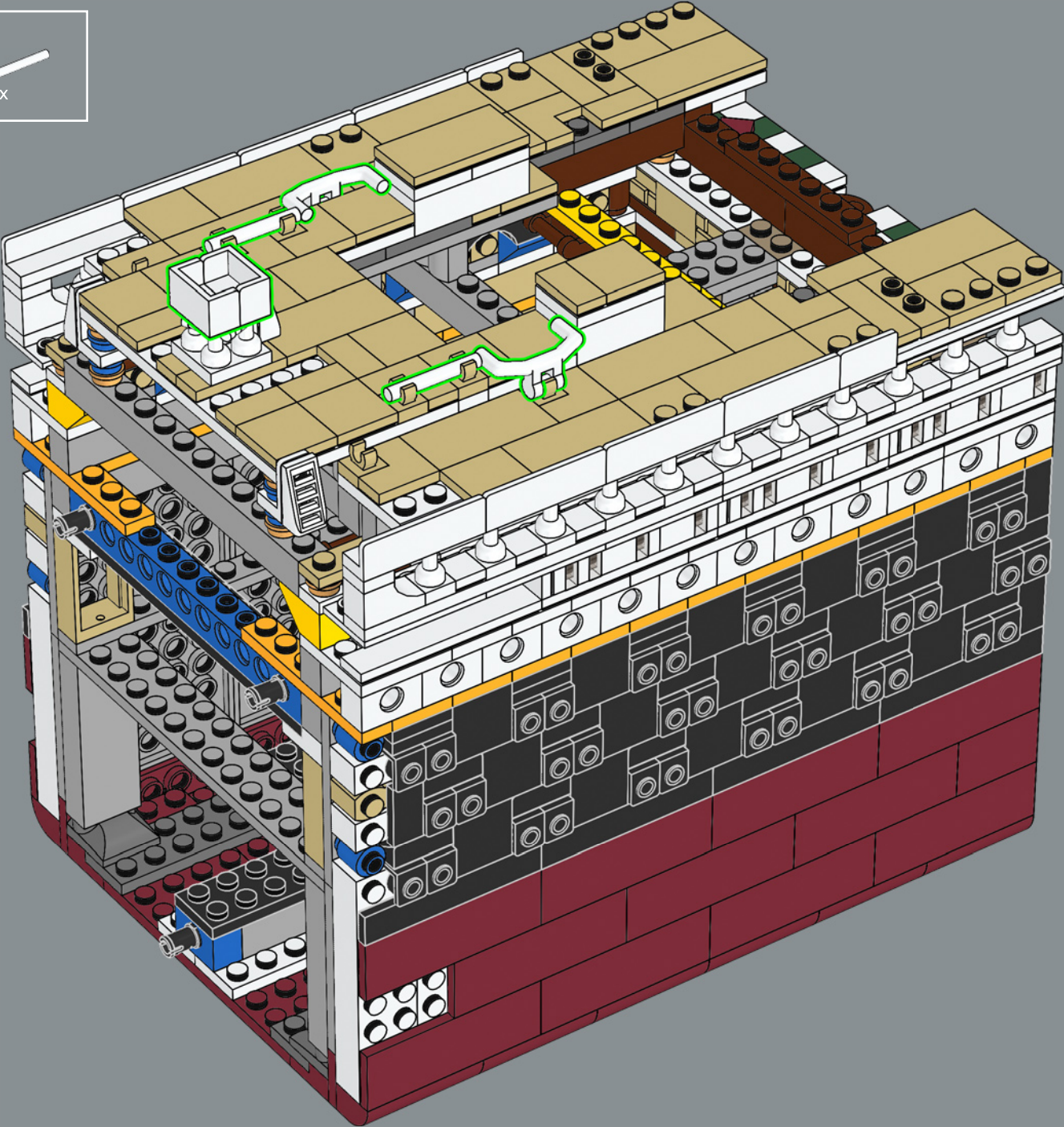

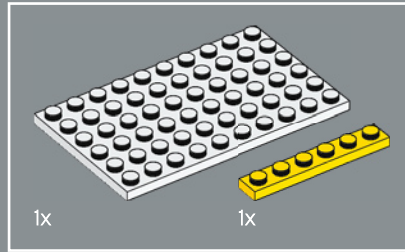
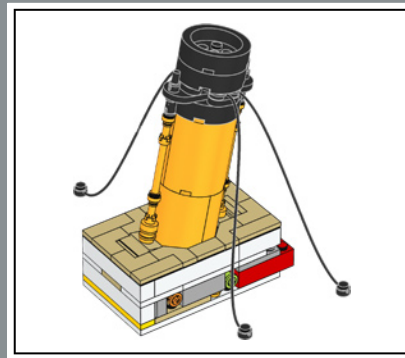
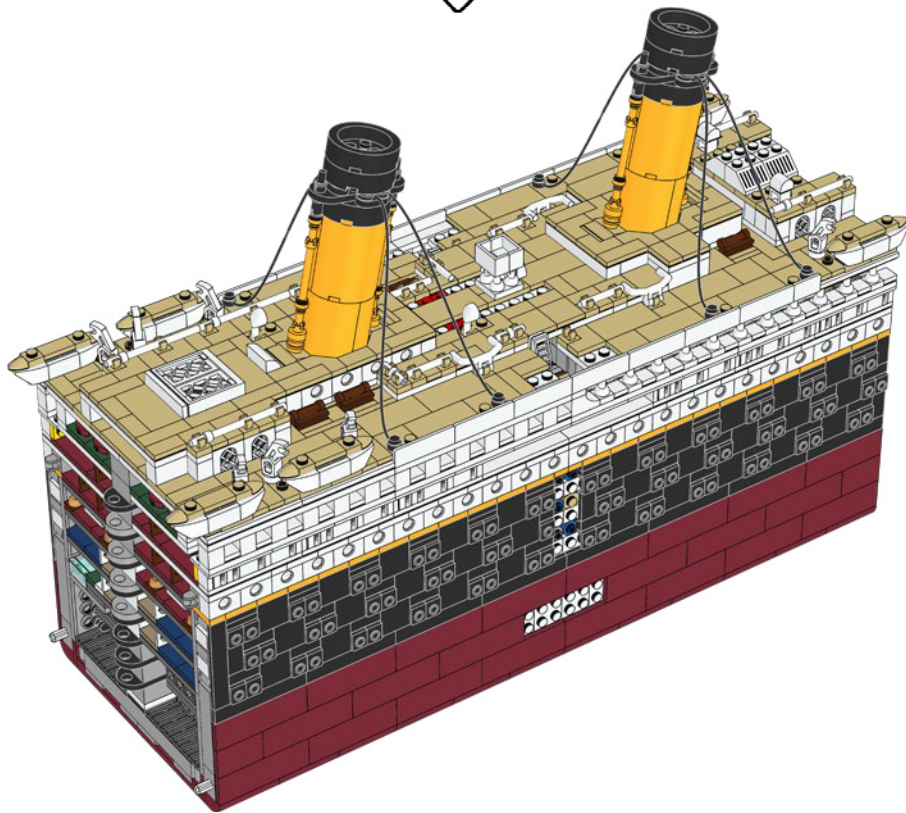
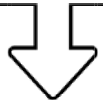

229

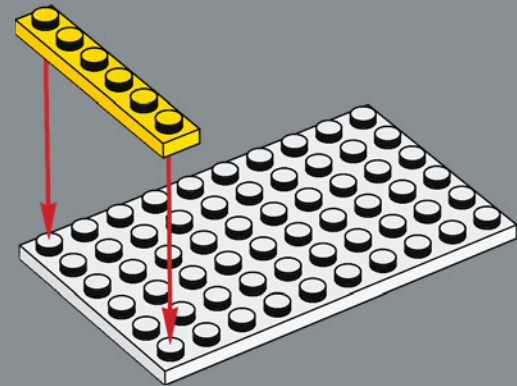

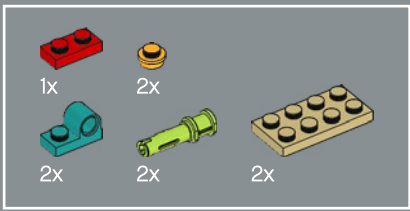

230

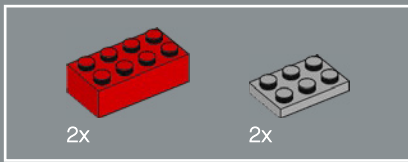
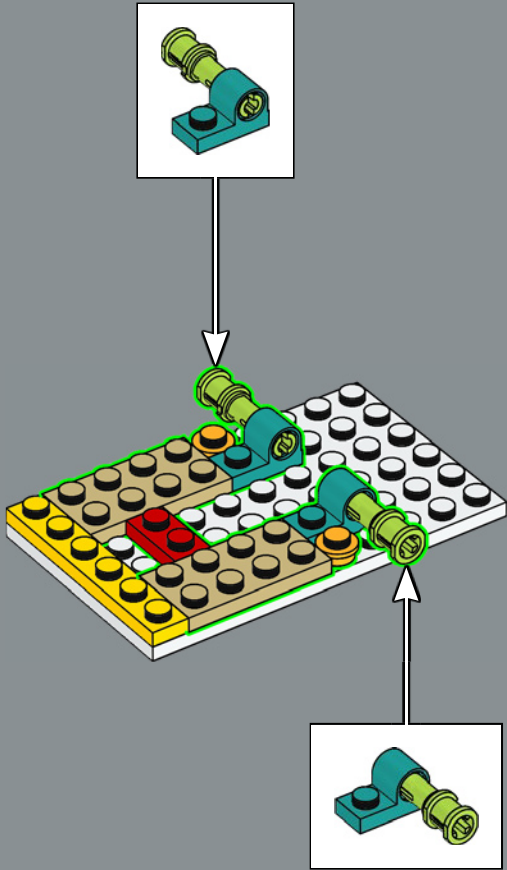

231

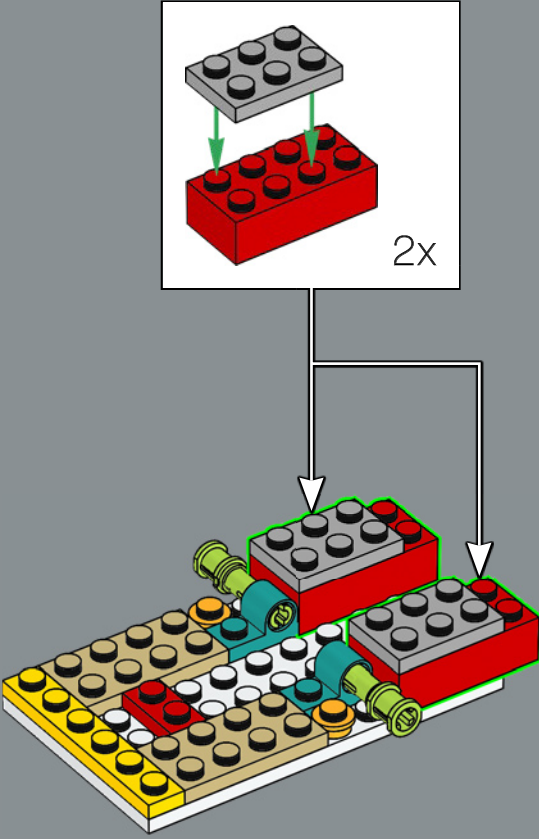

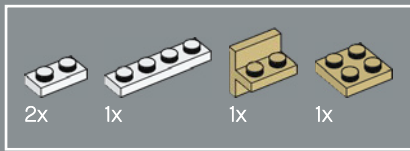

232

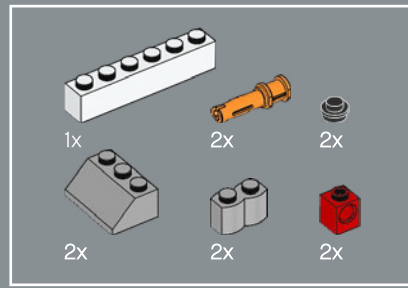
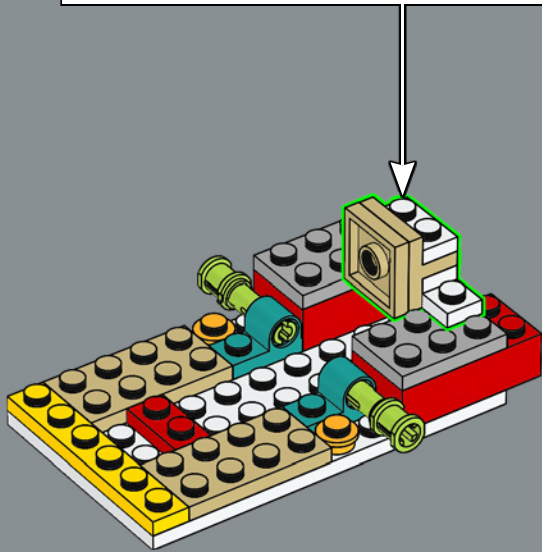
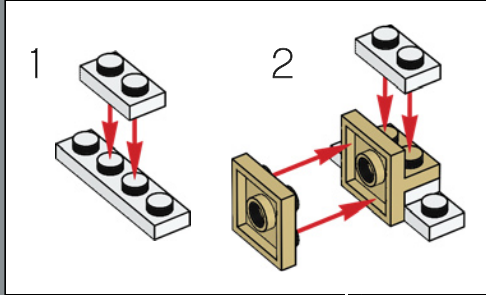

233

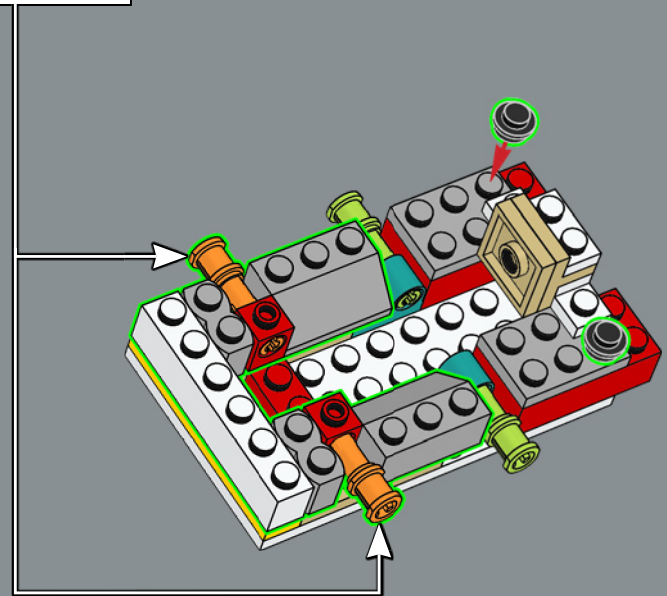
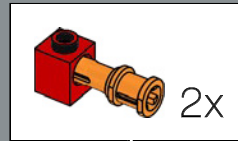

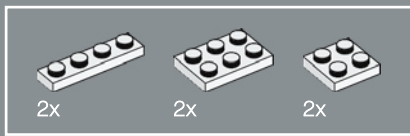

234

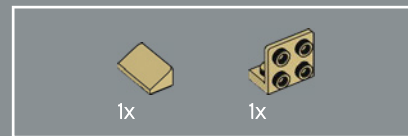
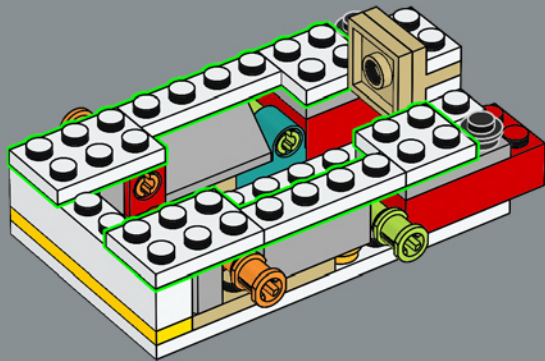

235

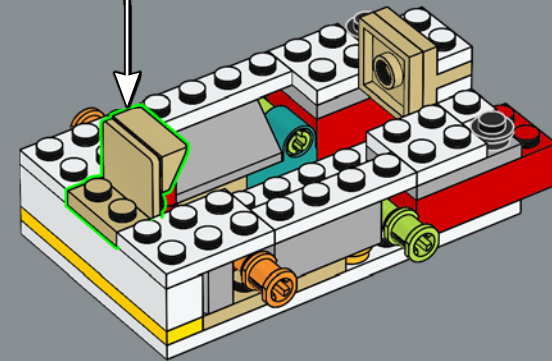
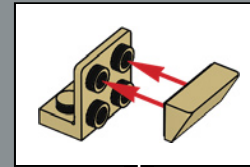

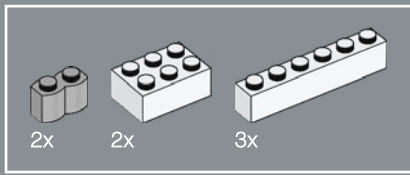

236

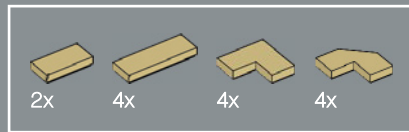
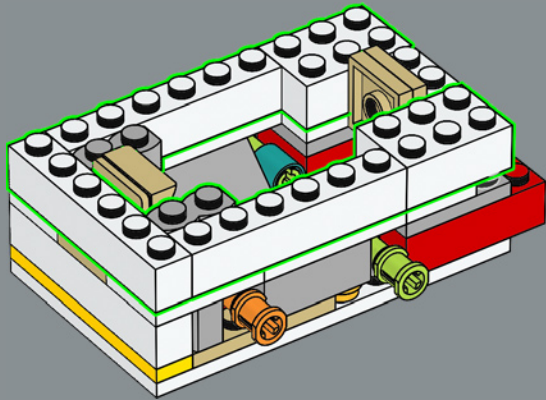

237

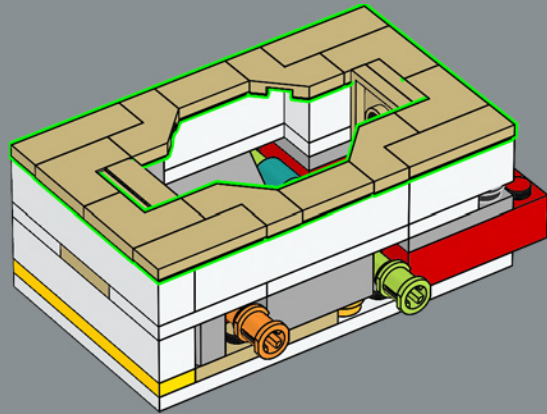

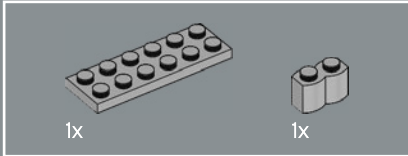
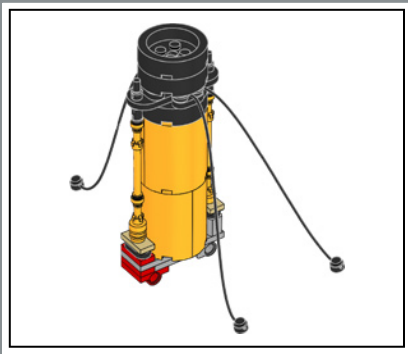

238

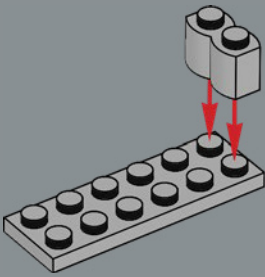

239

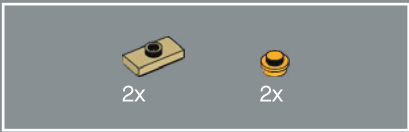
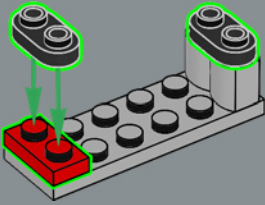

240

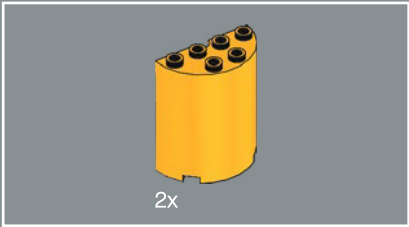
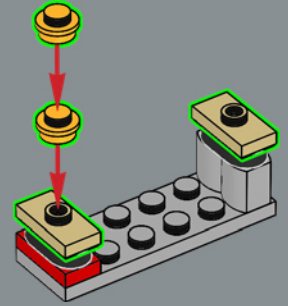

241

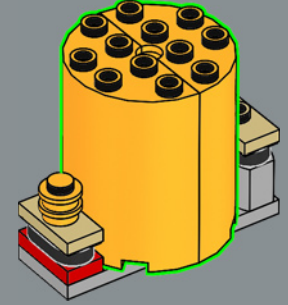

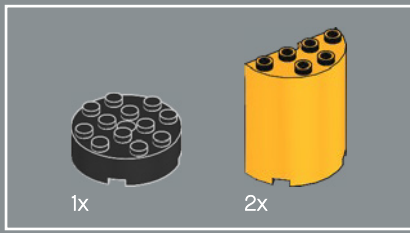

242

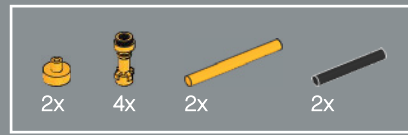
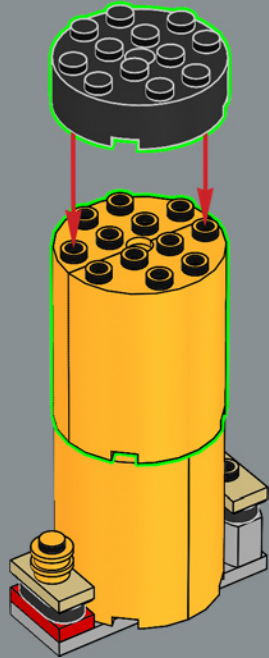

243

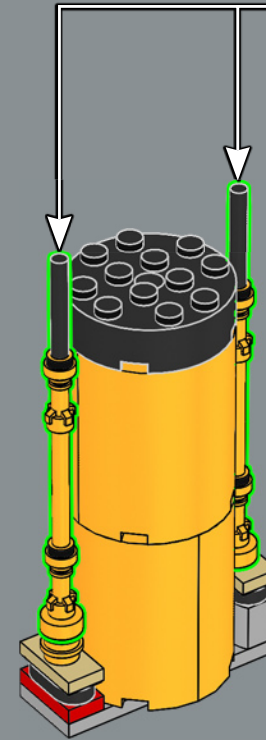
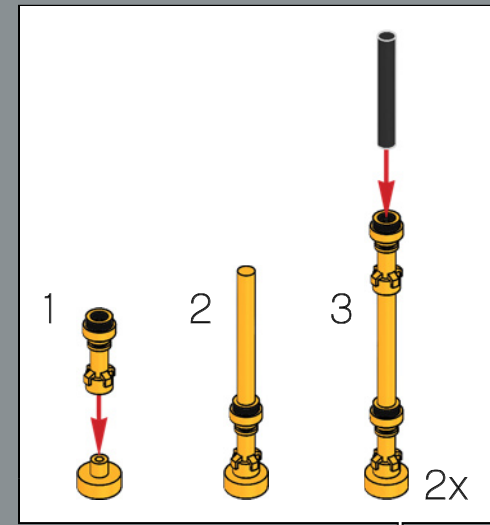

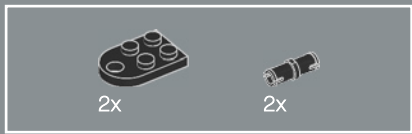

244

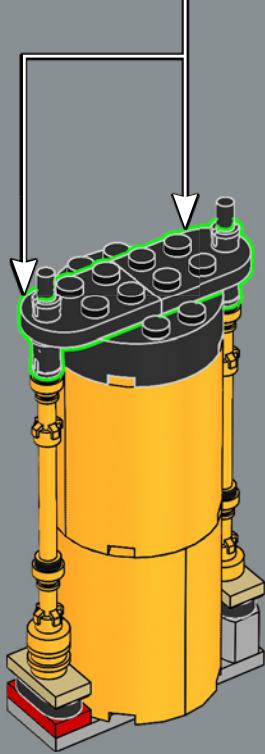
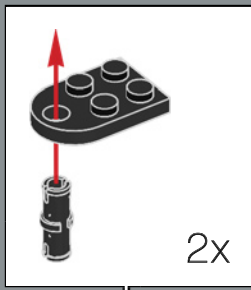

245

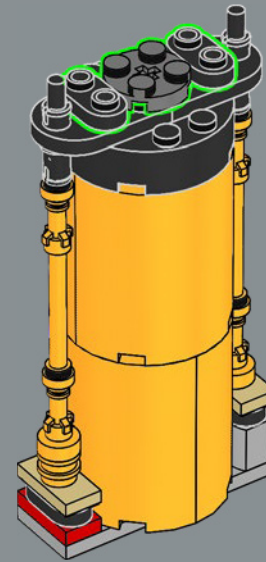

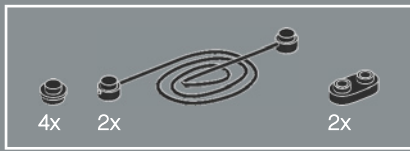

246

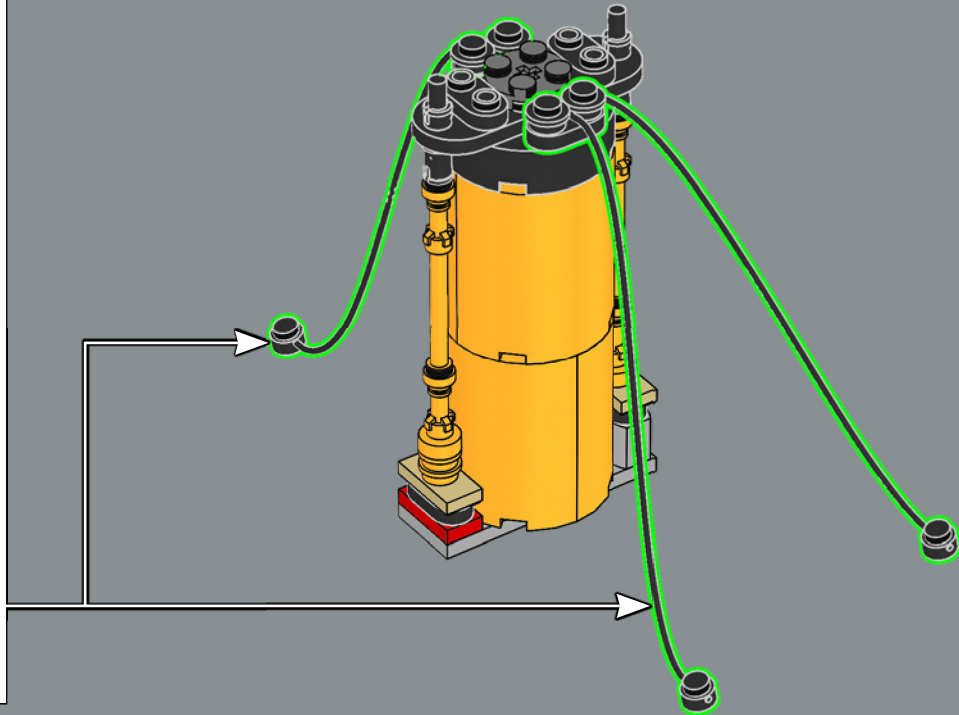
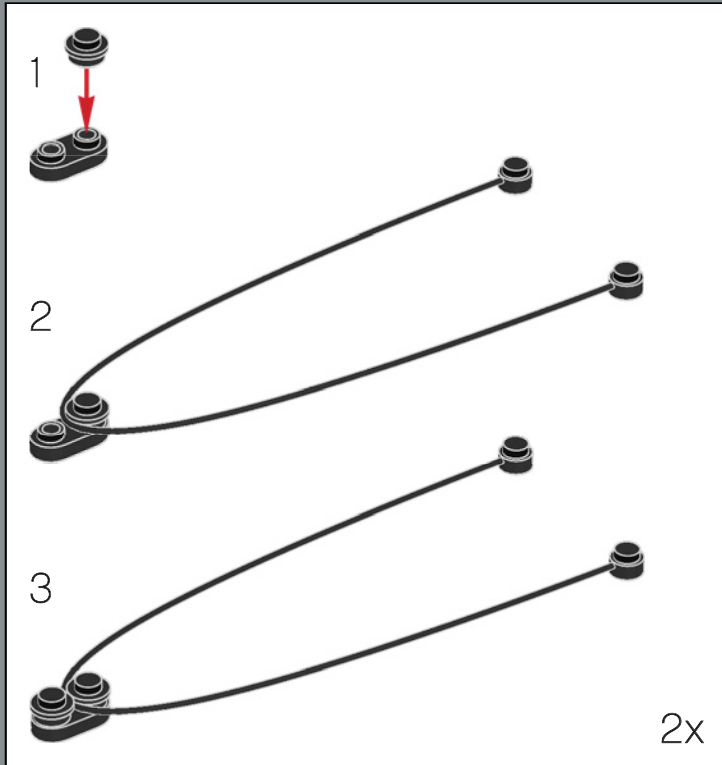

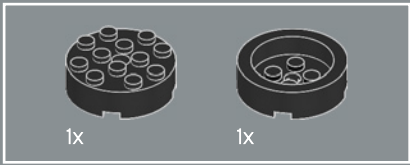

247

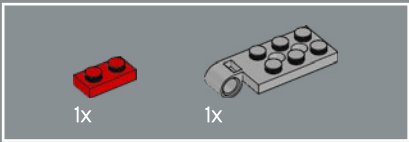
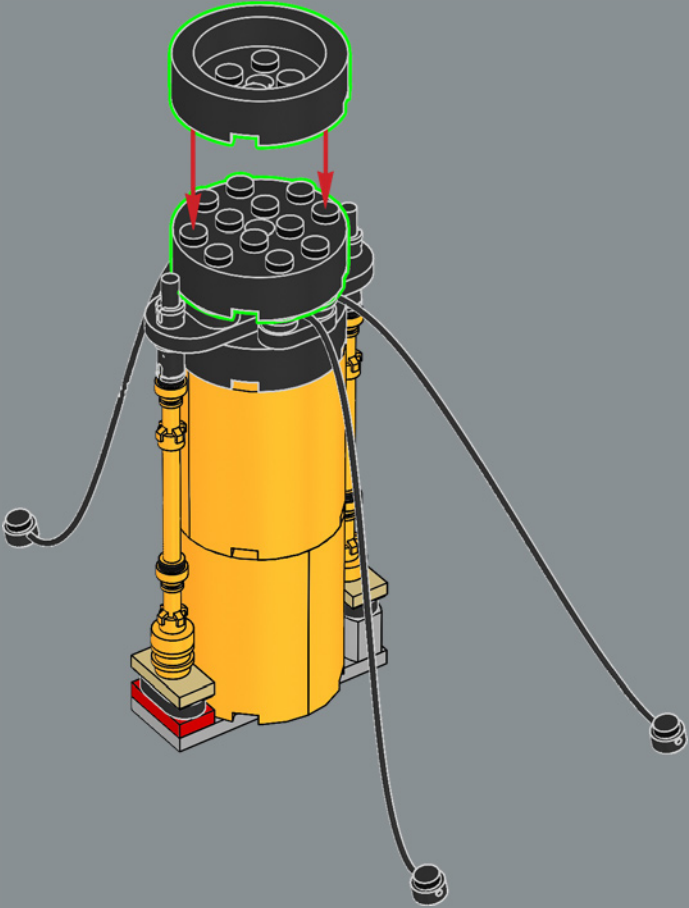

248

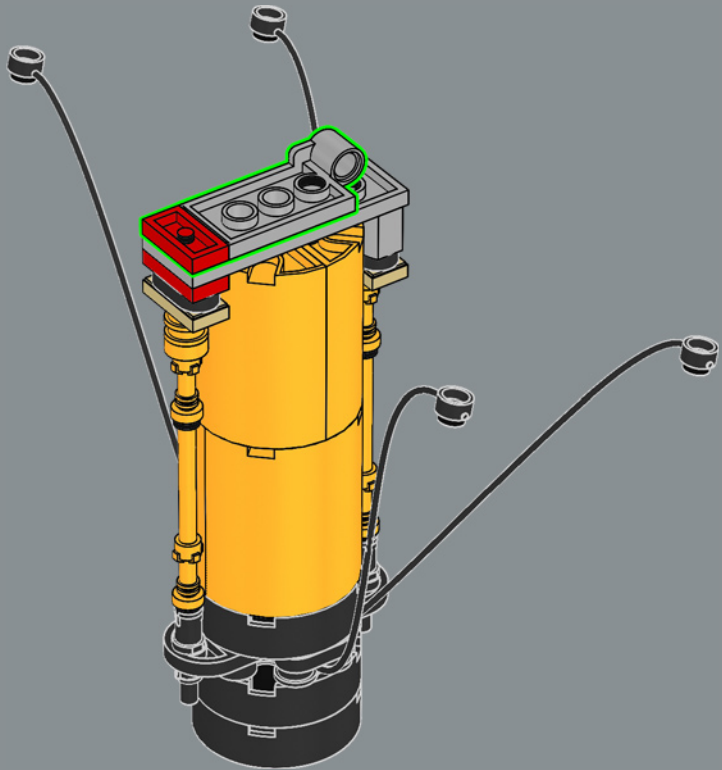

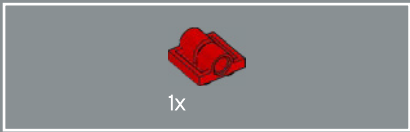

249

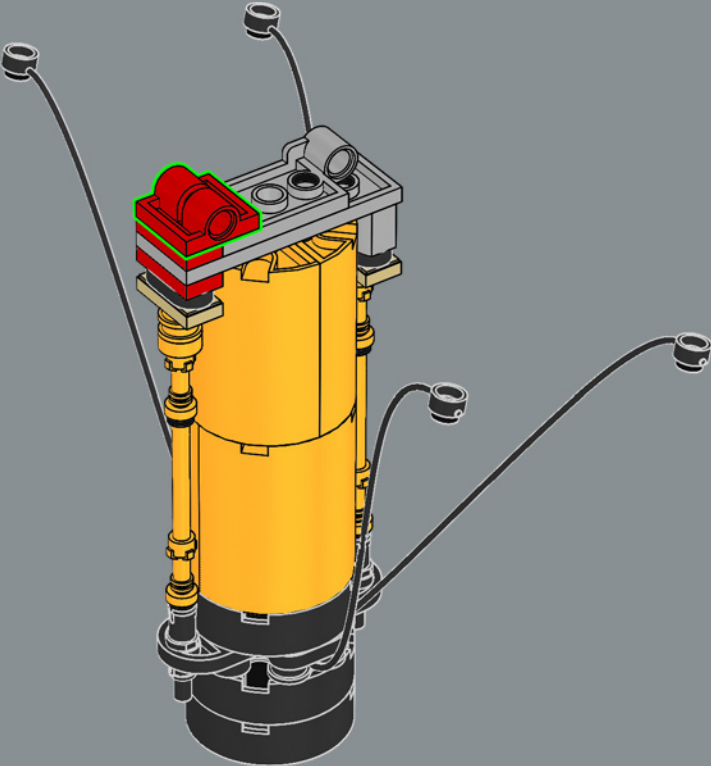

250

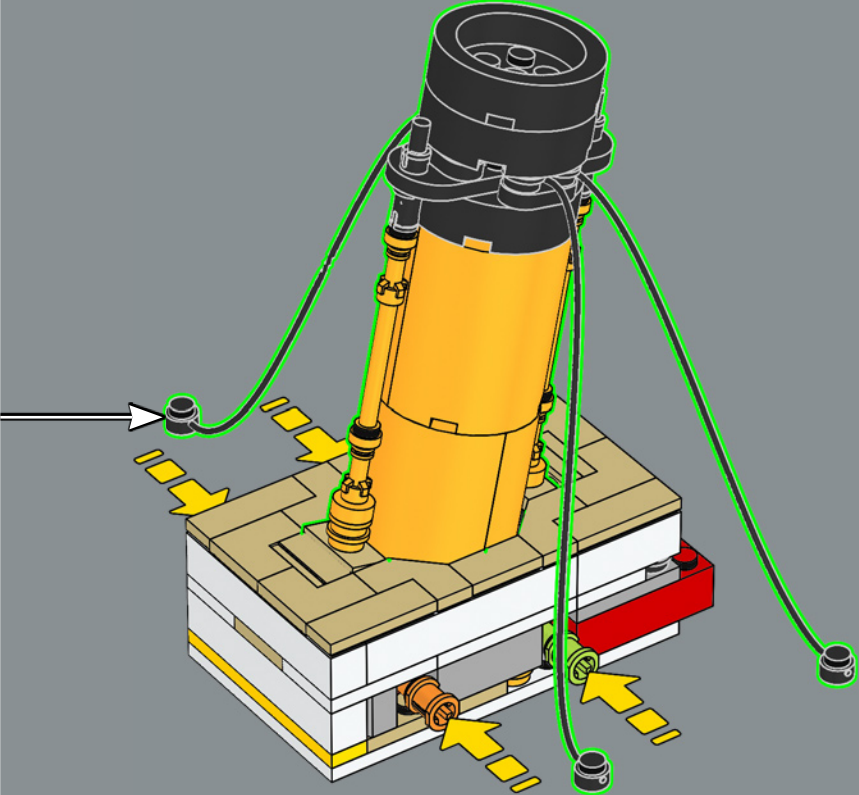

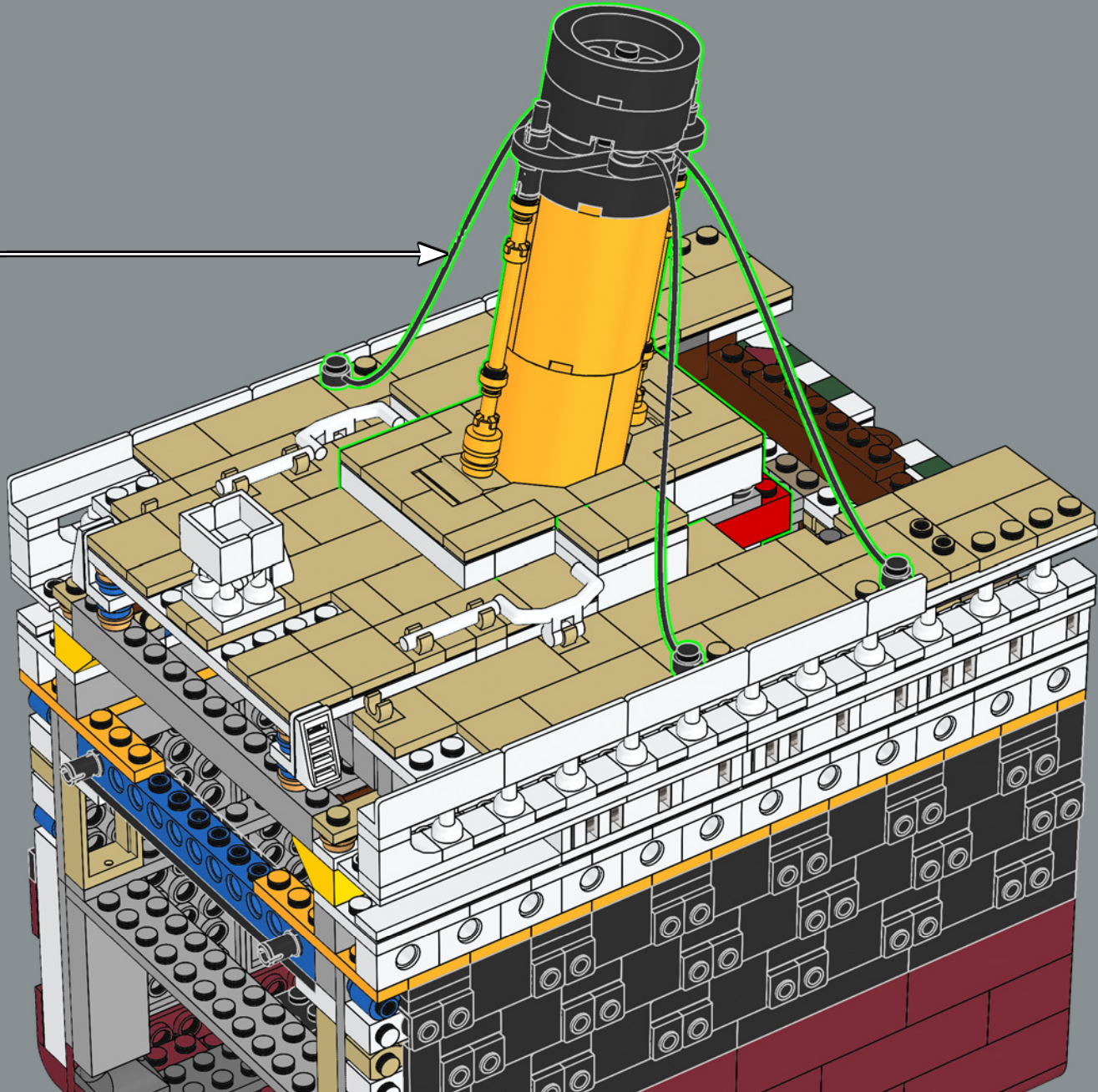

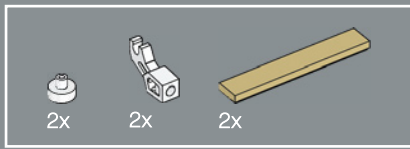

252

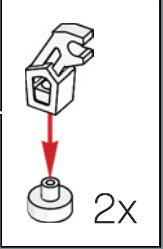
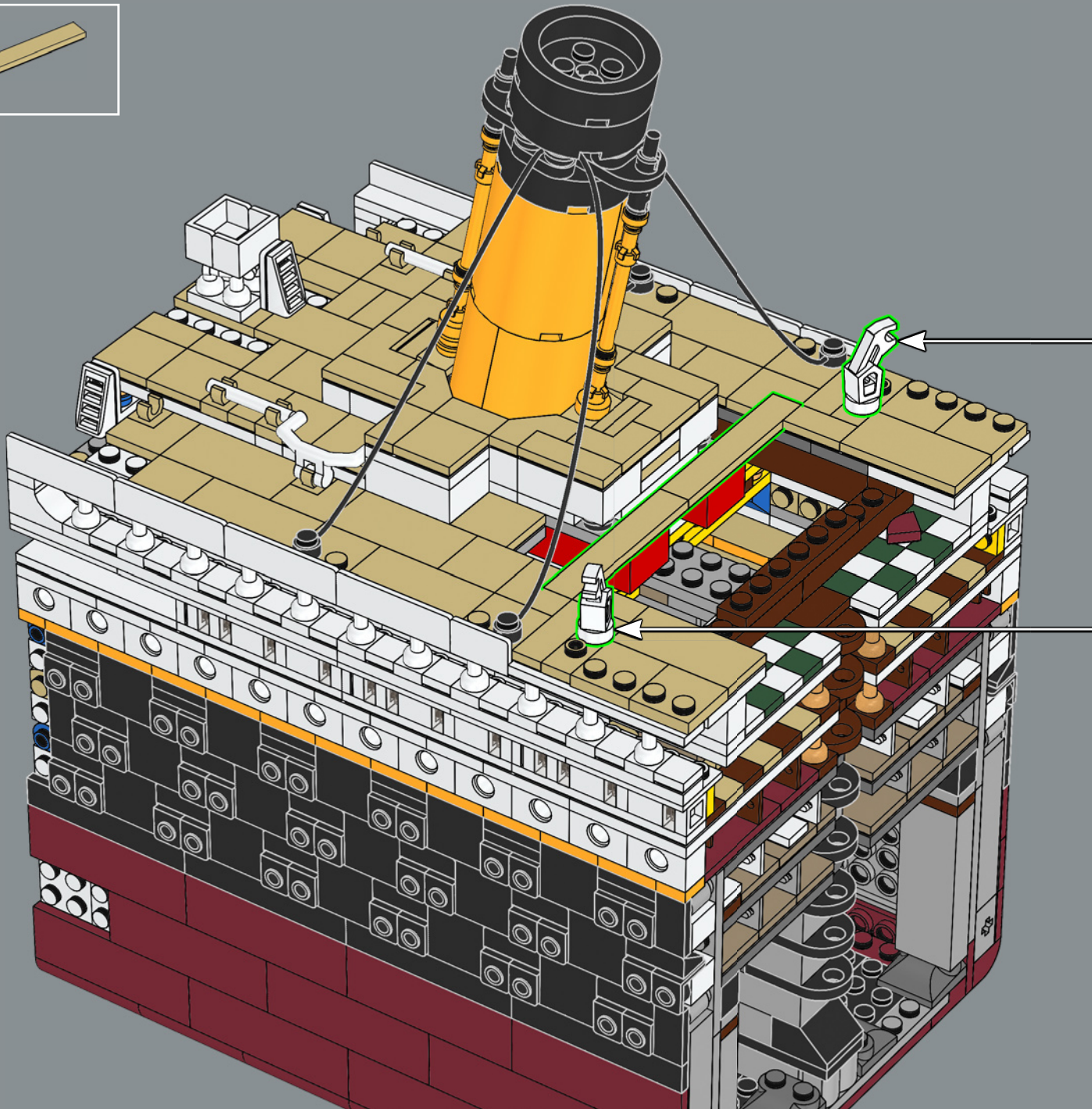

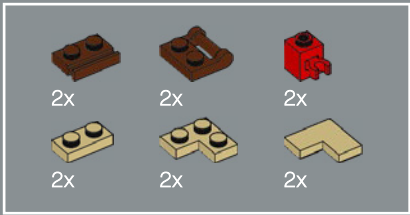

253

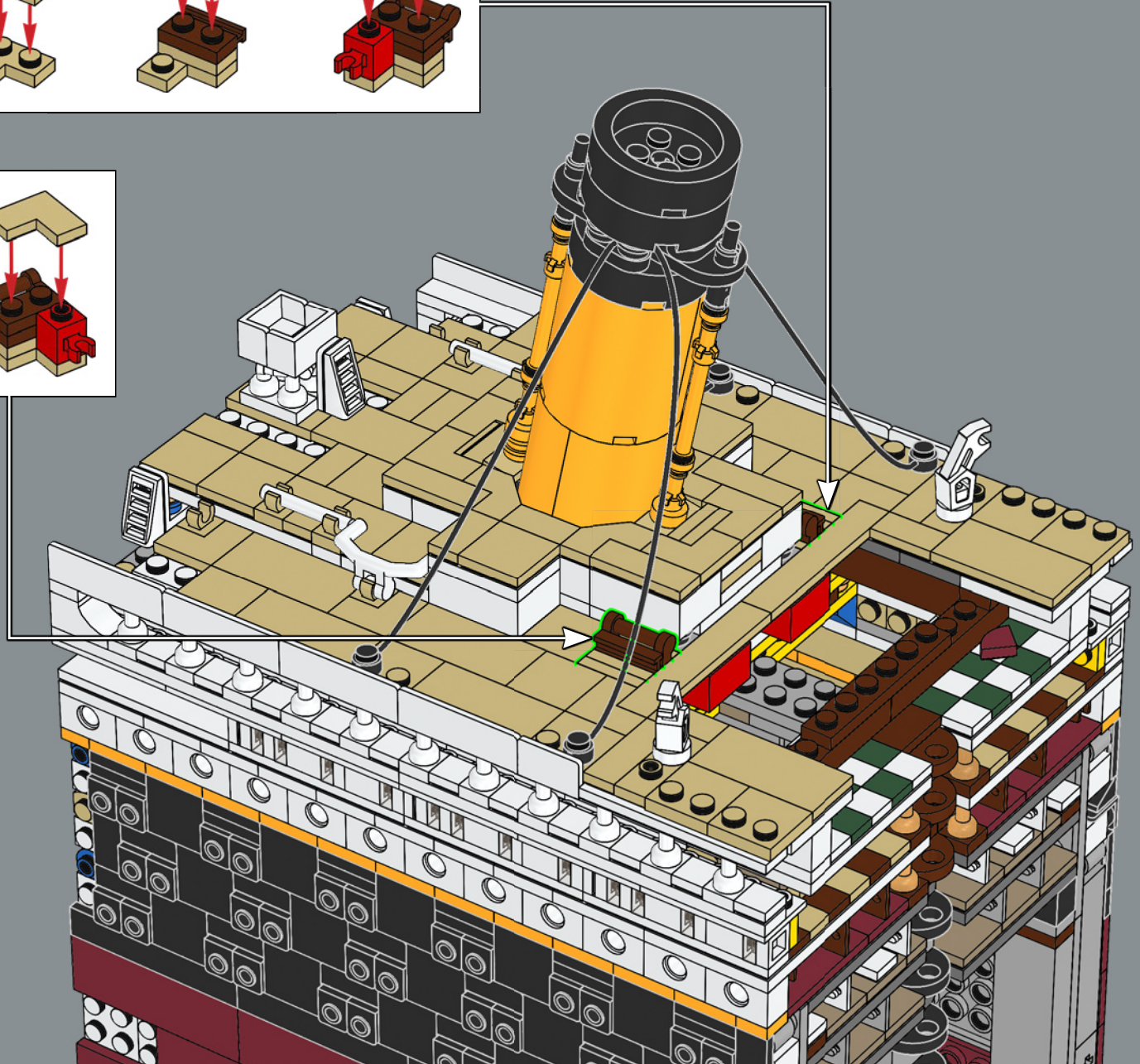
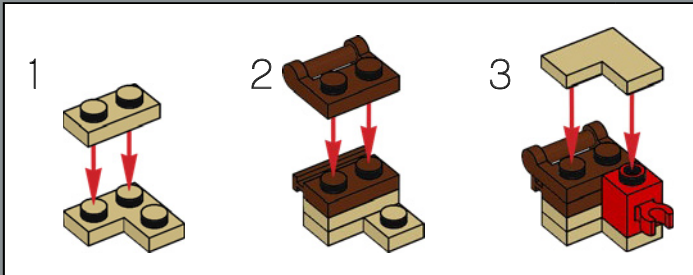
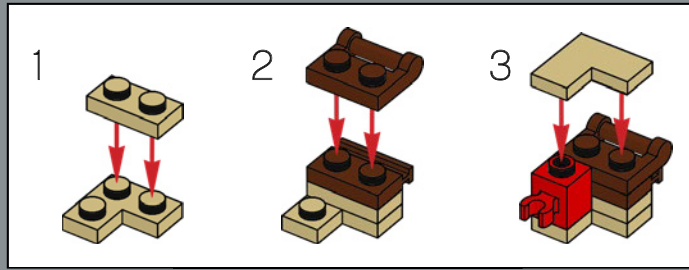

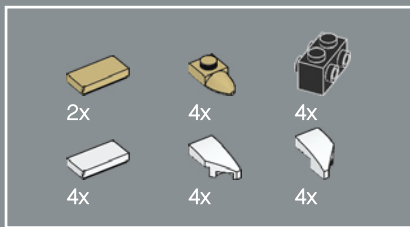

254

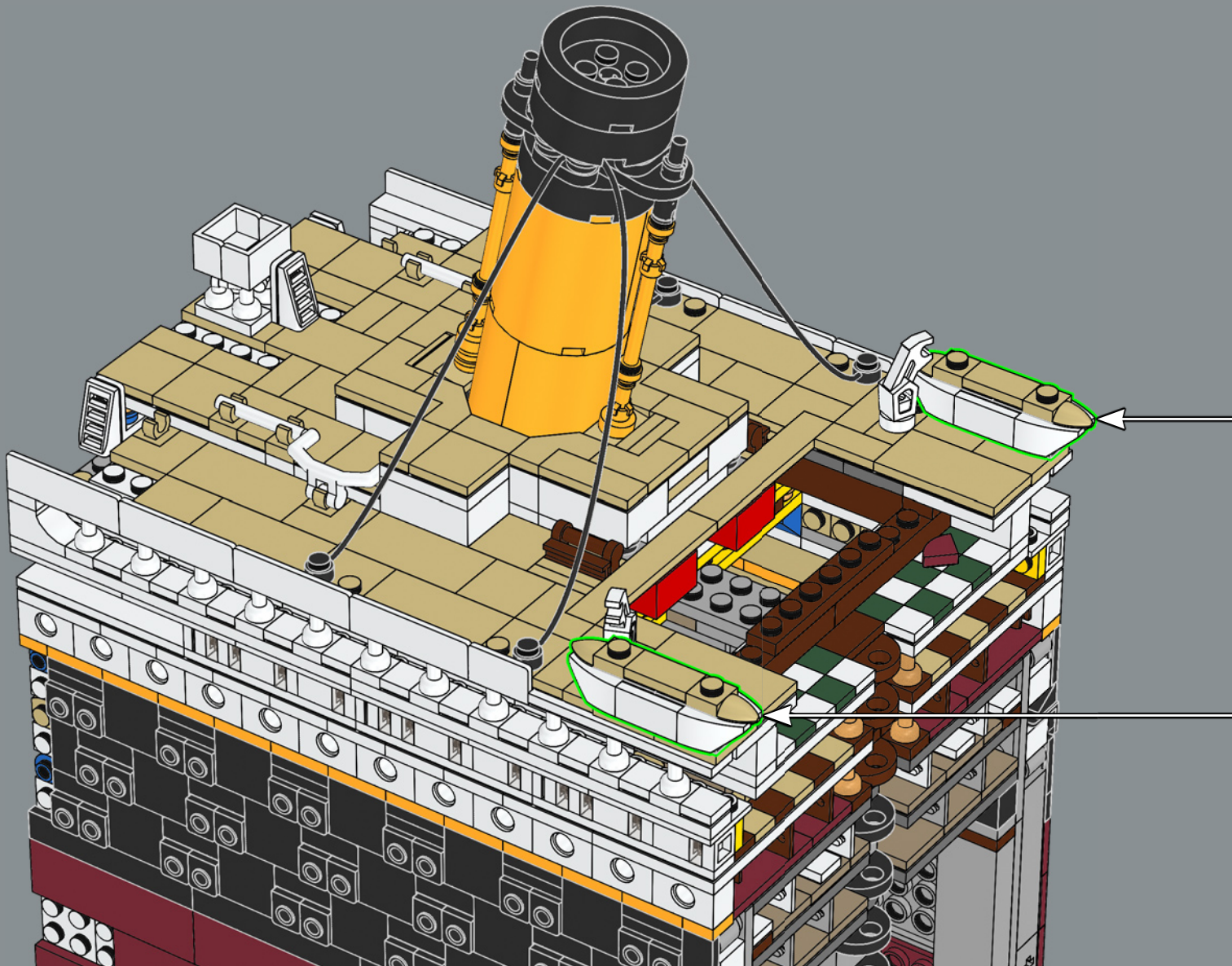
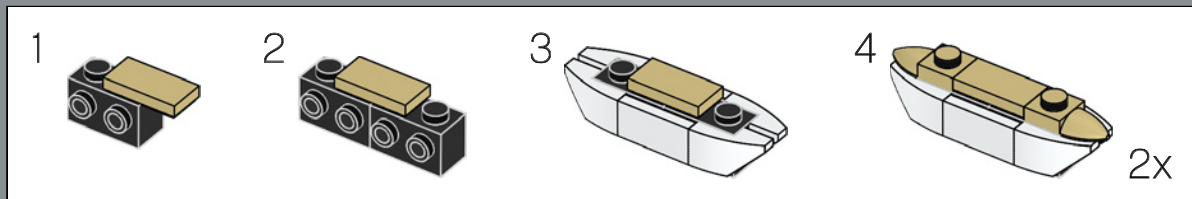

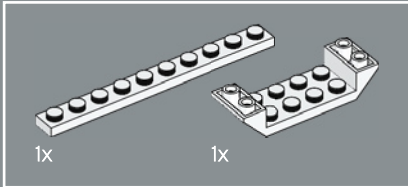
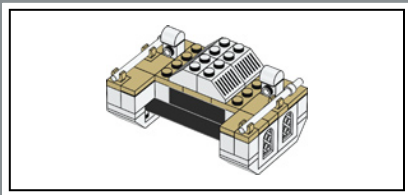

255

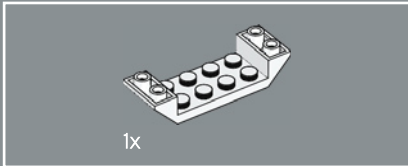
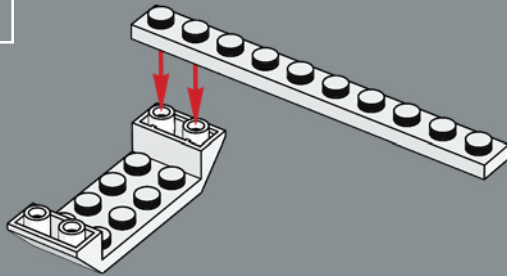

256

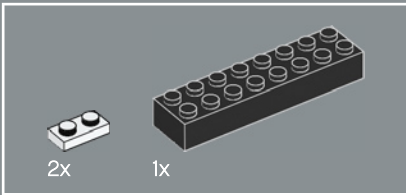
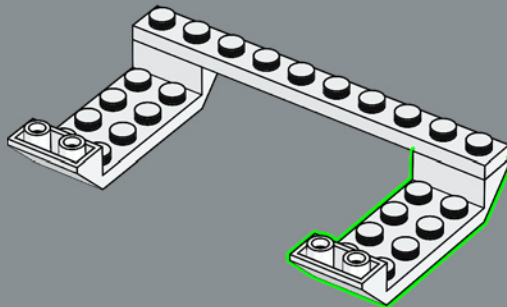

257

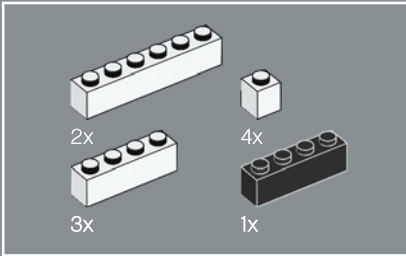
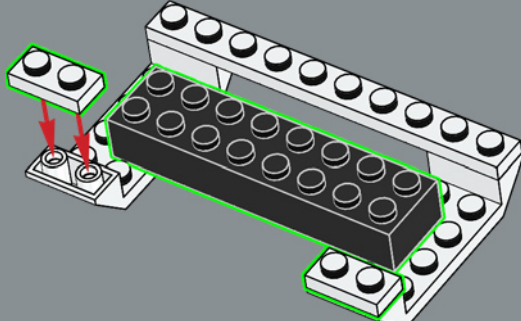

258

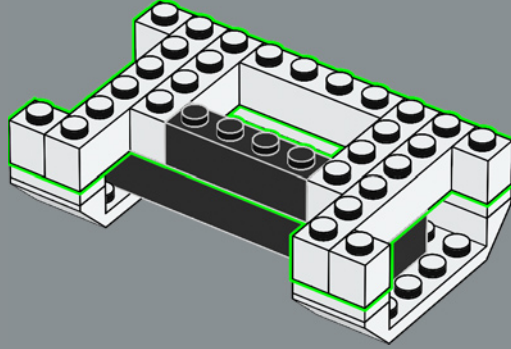

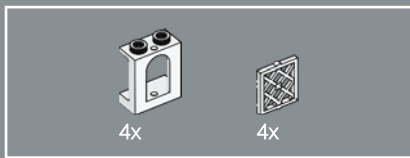

259

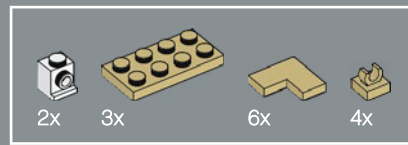
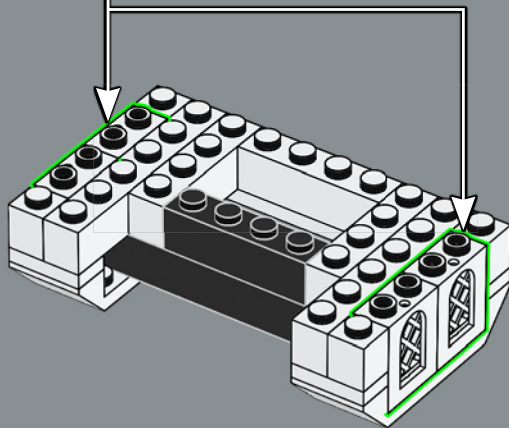
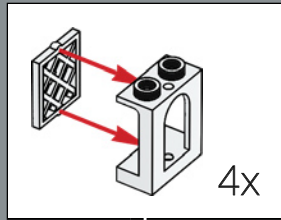

260

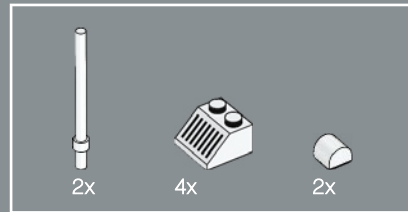
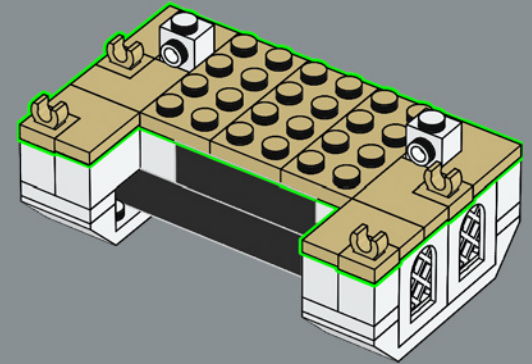

261

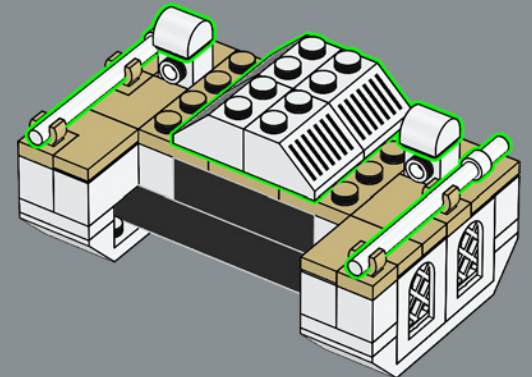

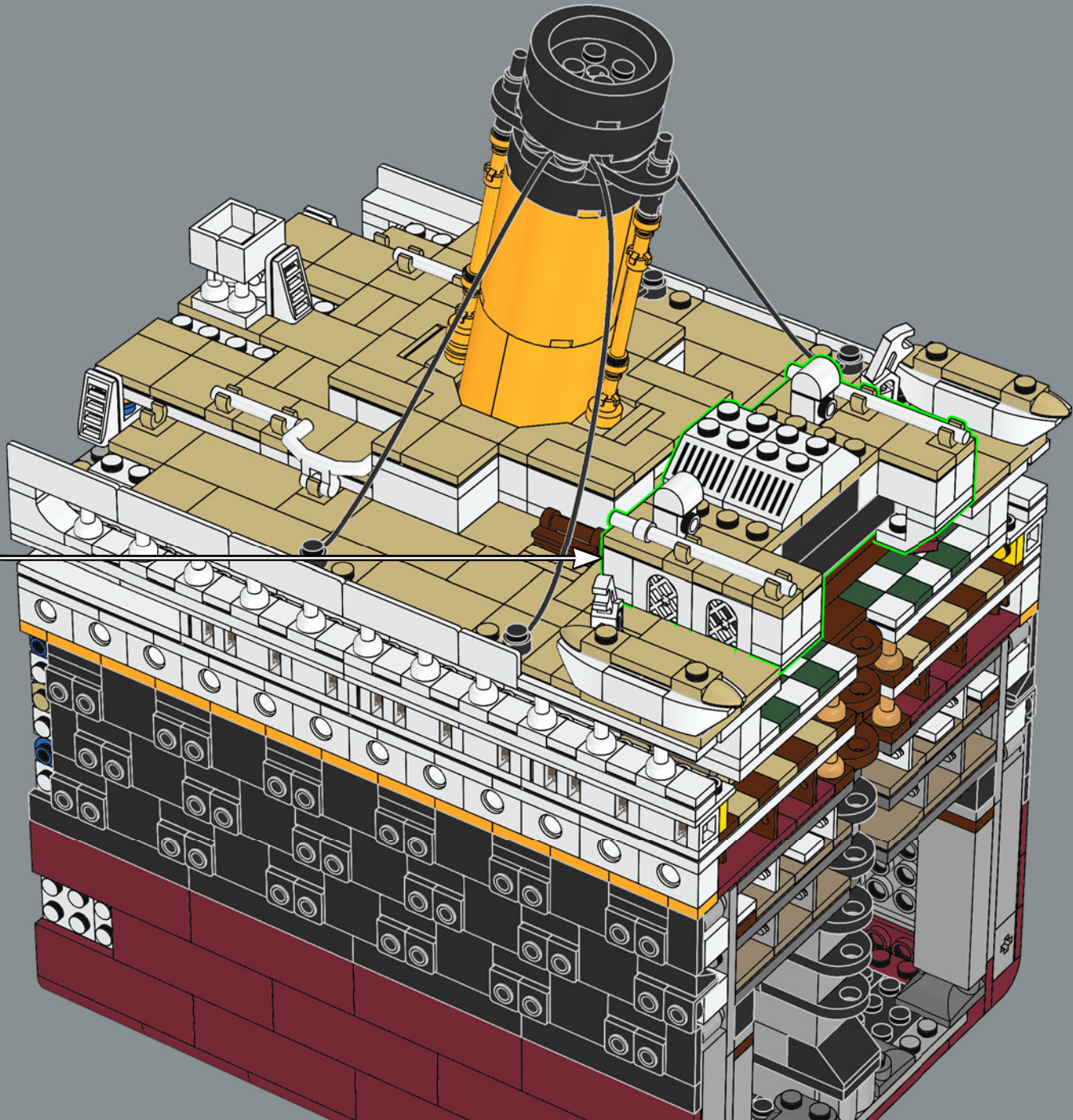

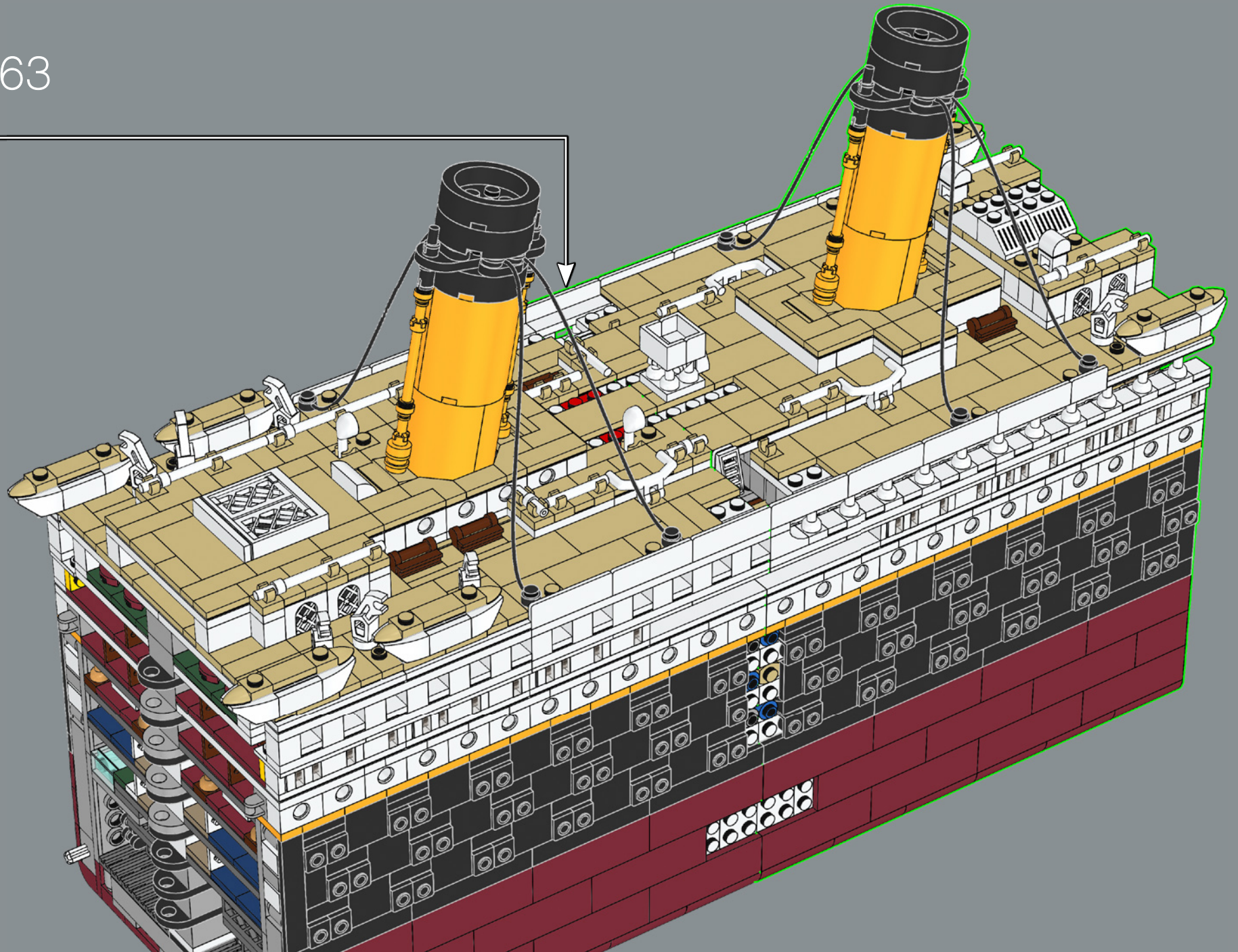

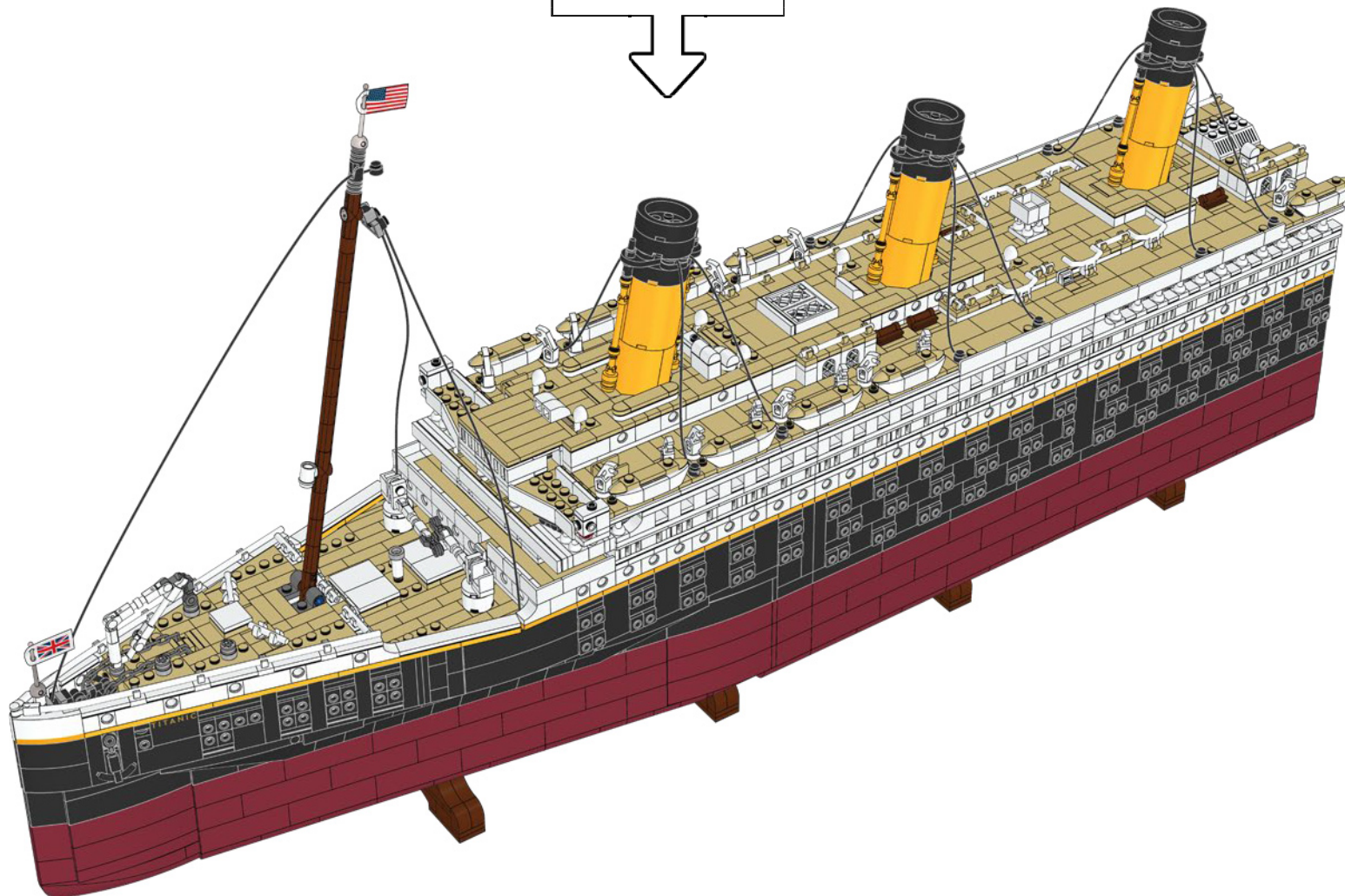

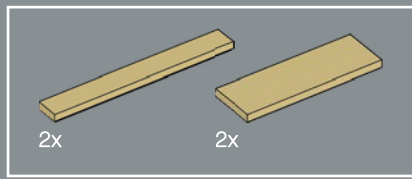

264

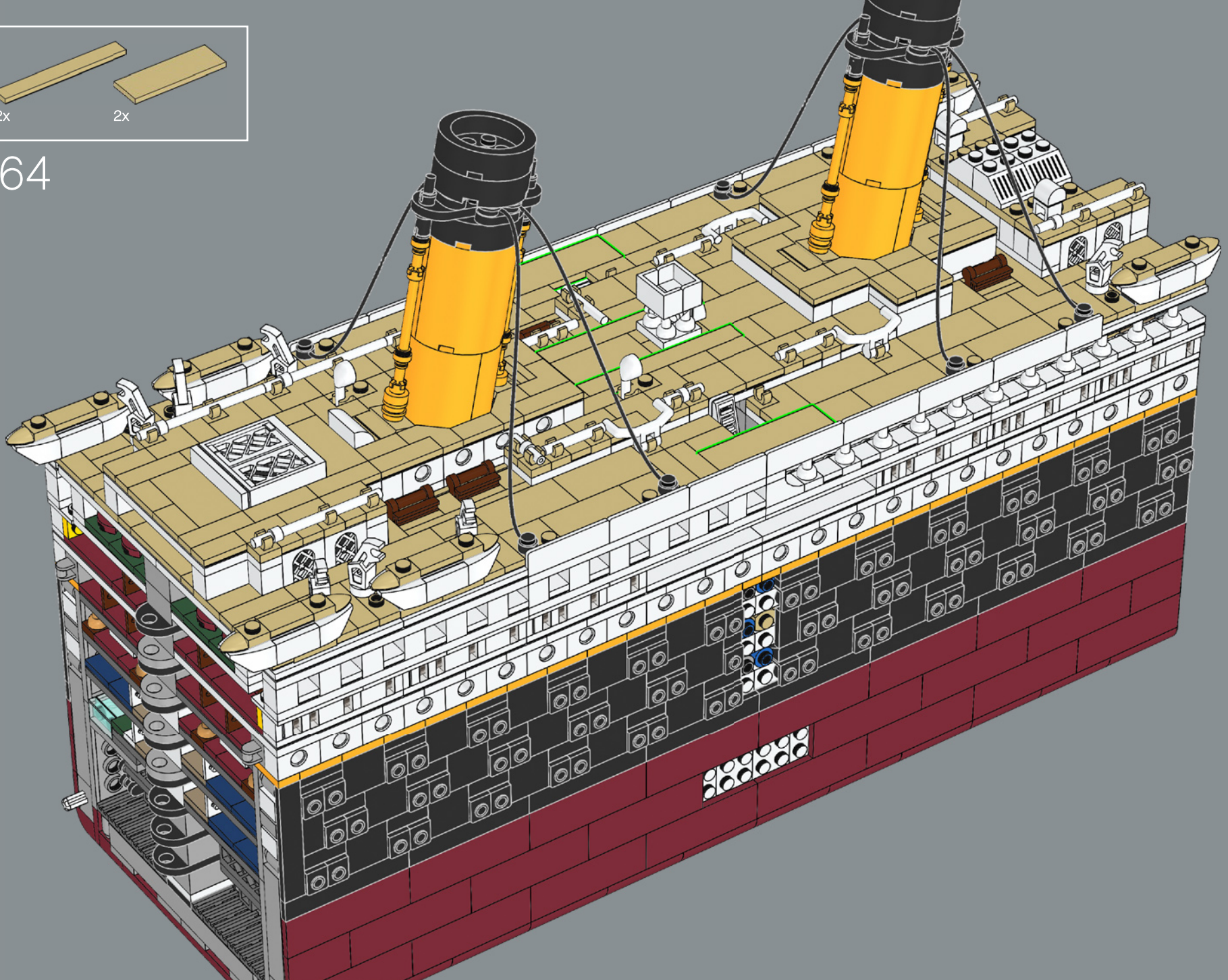

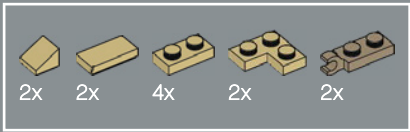

265

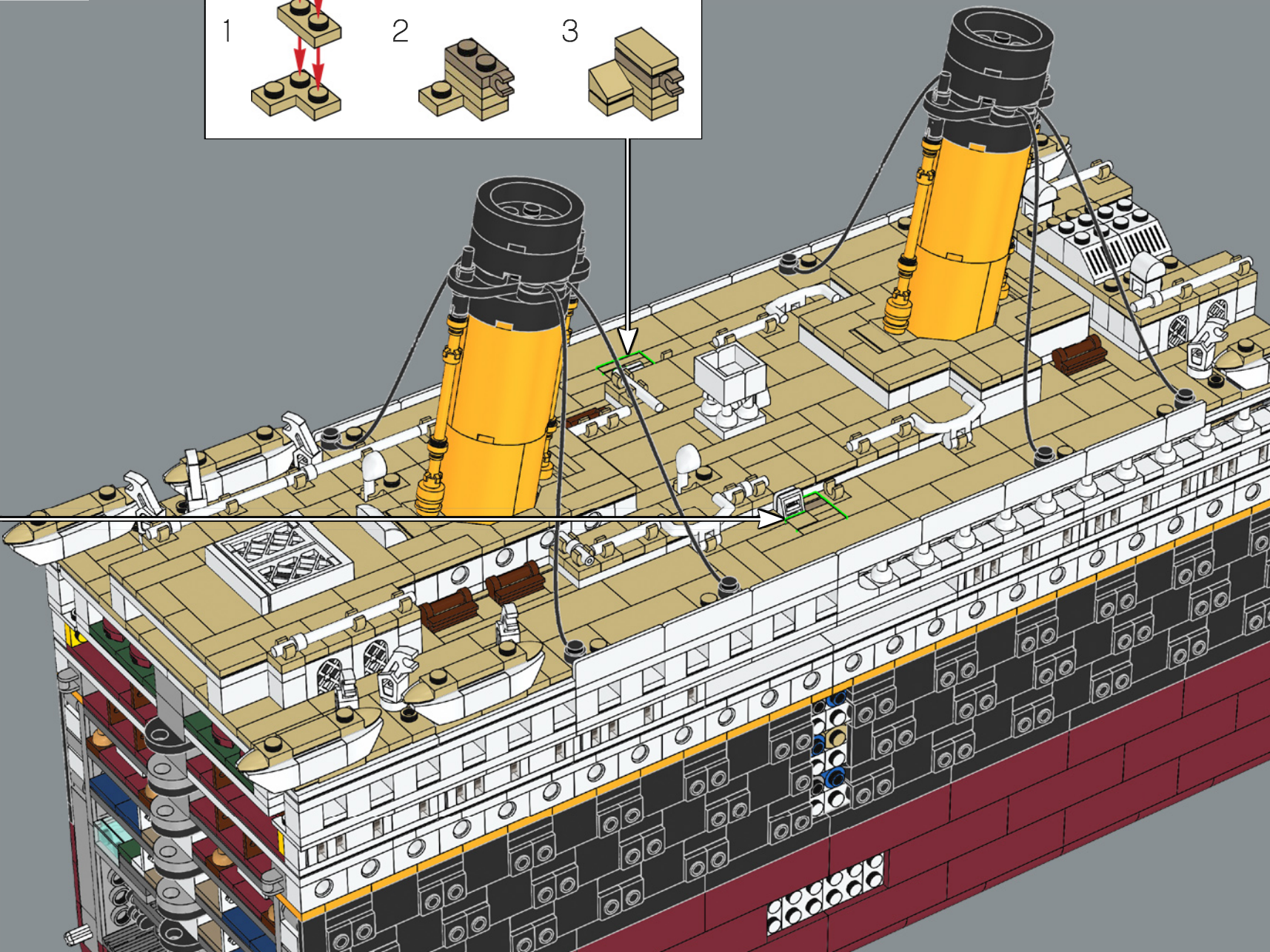
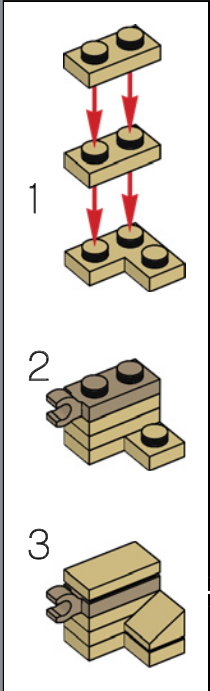
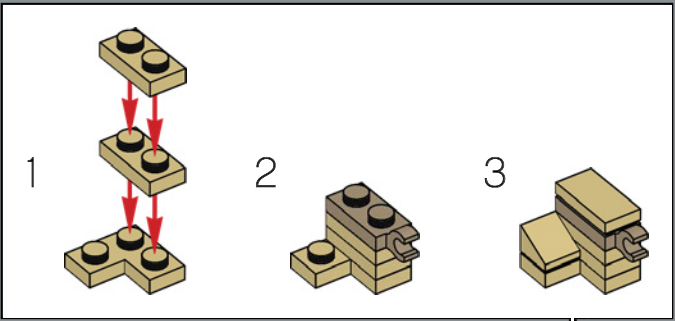

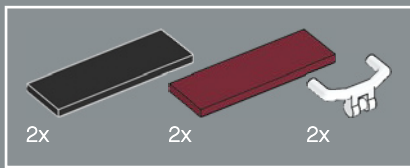

266

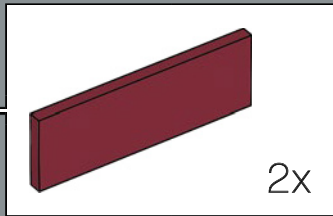
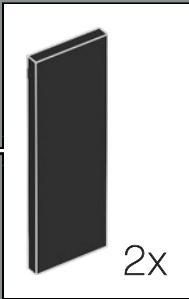
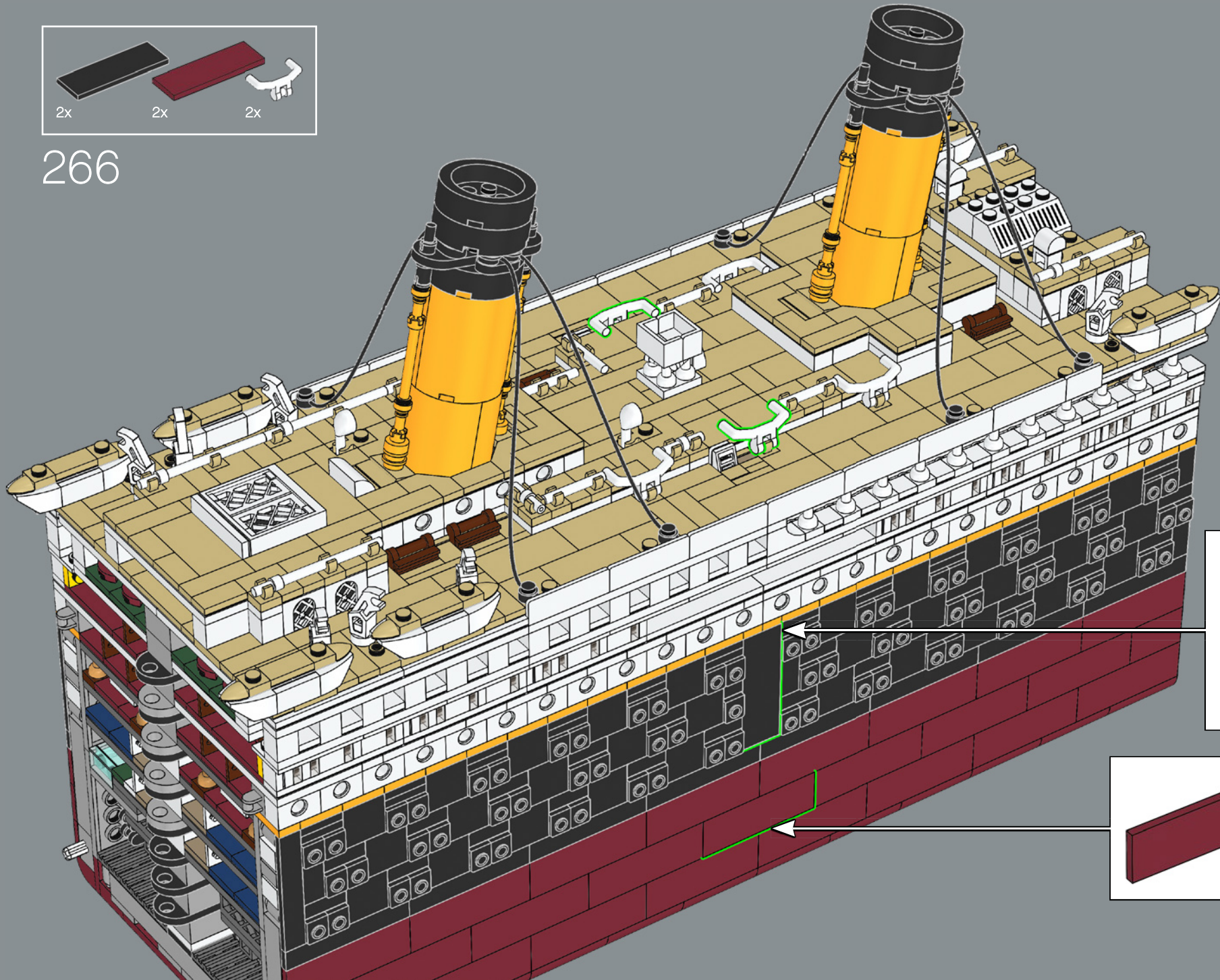

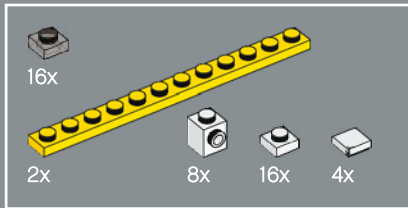
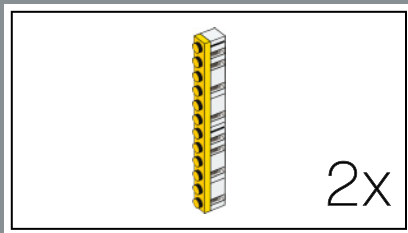

267

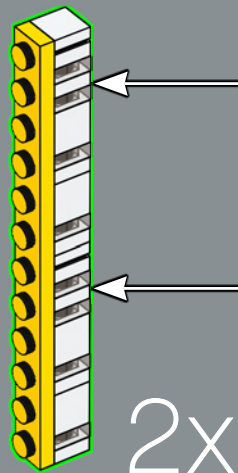
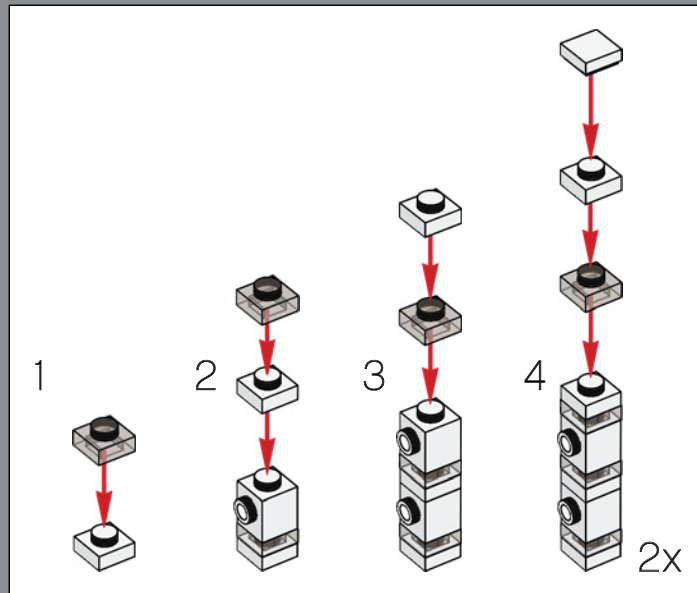

268

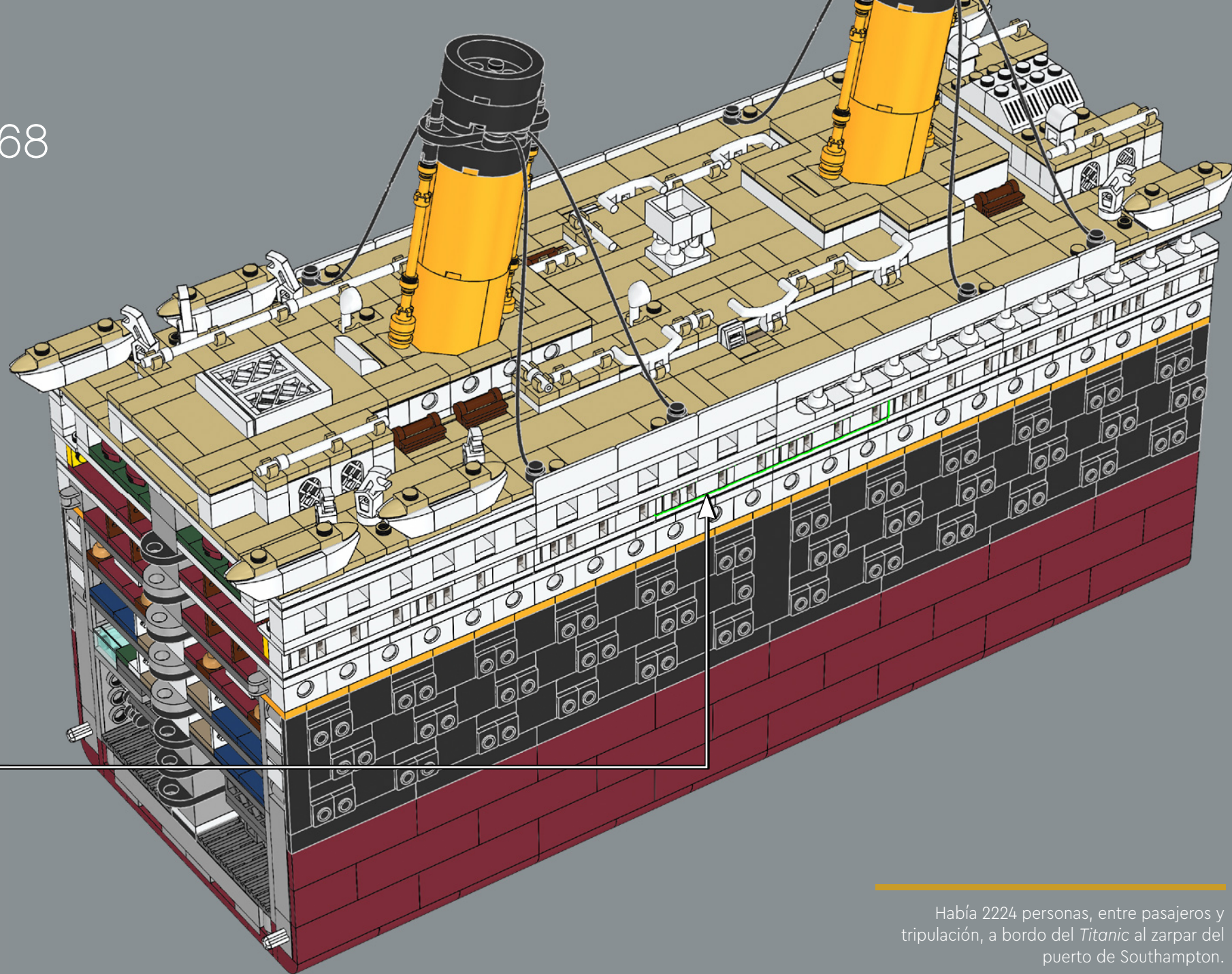

Había 2224 personas, entre pasajeros y tripulación, a bordo del *Titanic* al zarpar del puerto de Southampton. 209

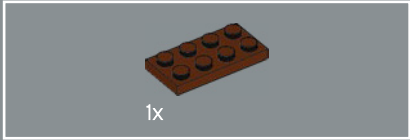
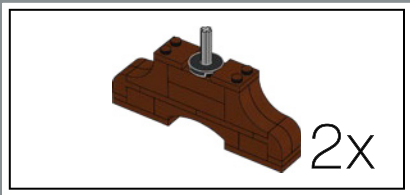

269

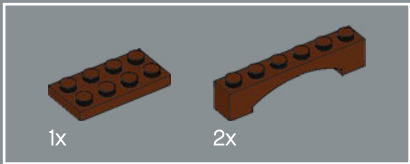
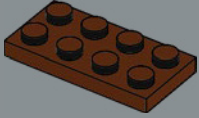

270

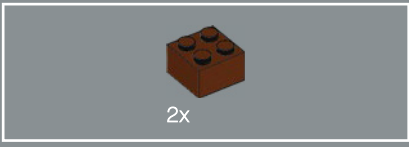
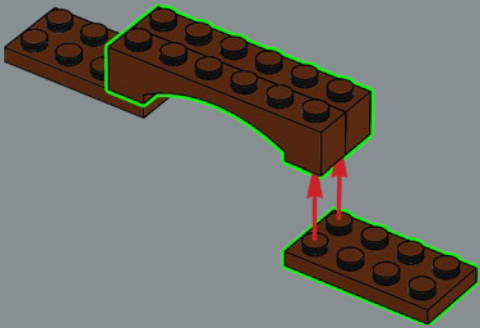

271

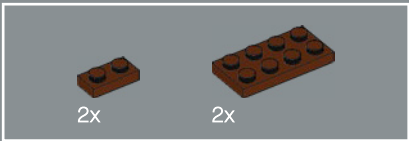
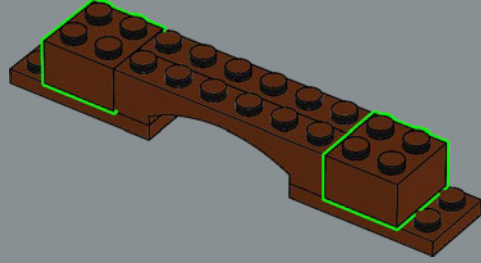

272

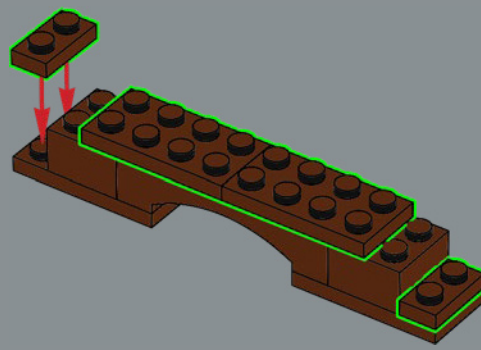



273

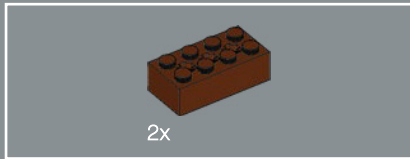
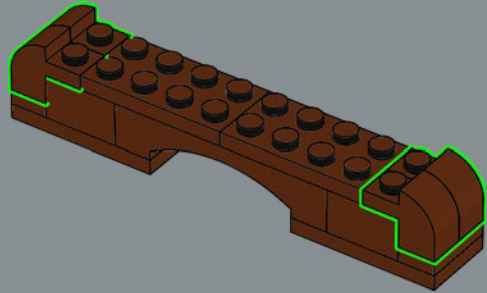

274

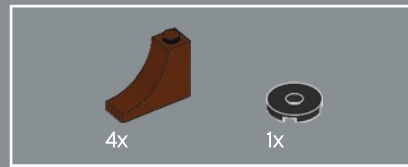
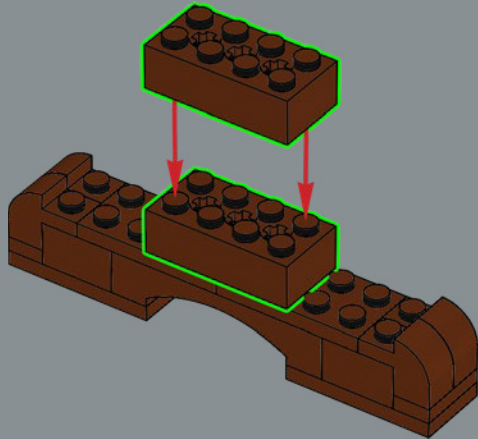

275

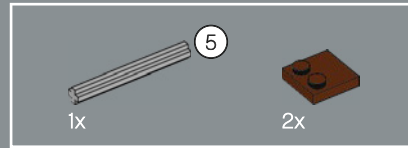
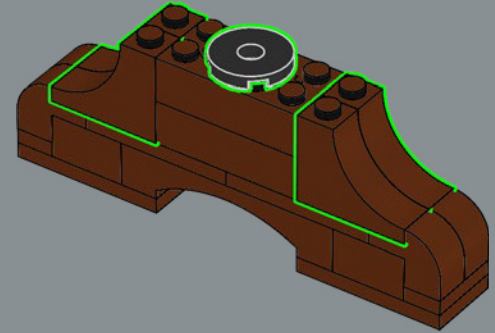

276

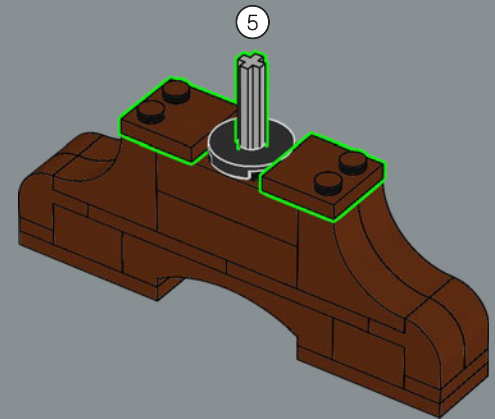

277

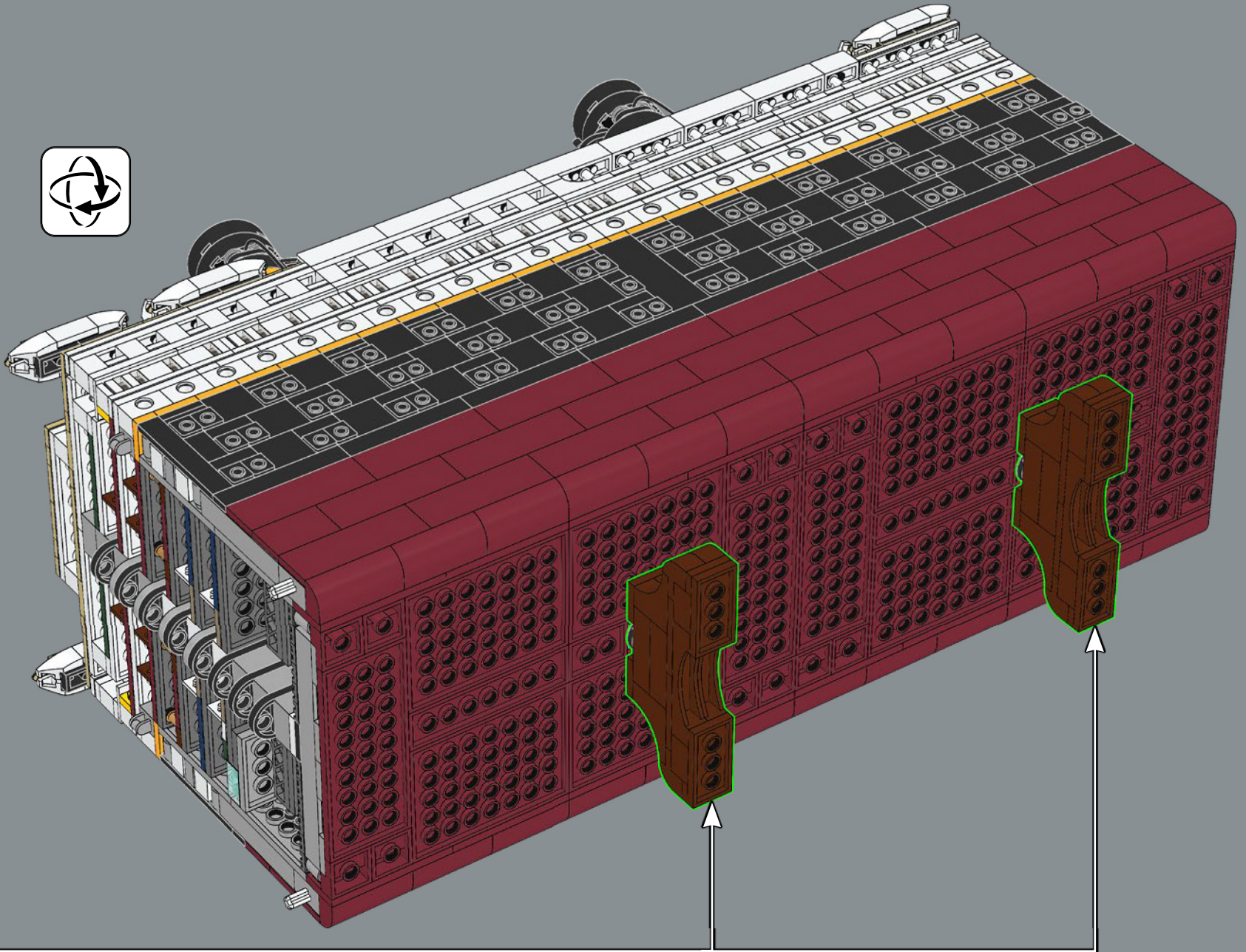

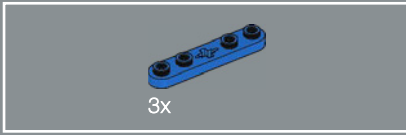
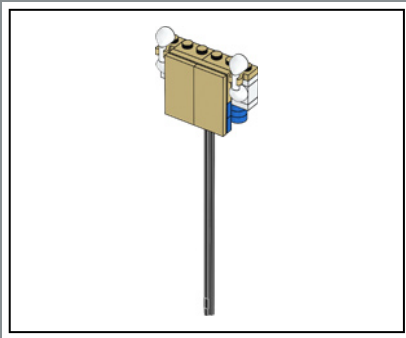

278

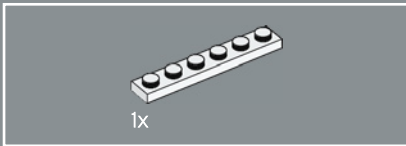
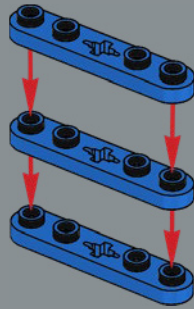

279

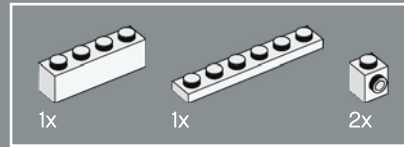
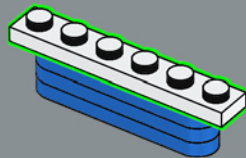

280

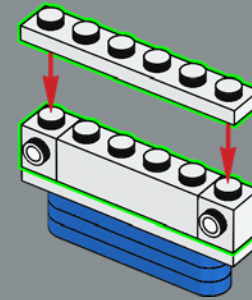

281

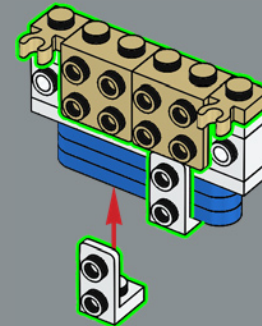

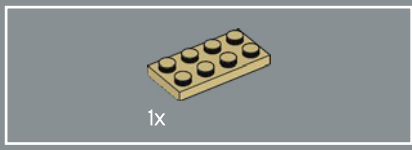

282

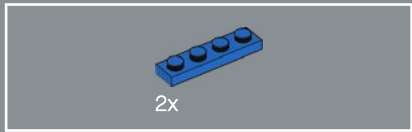
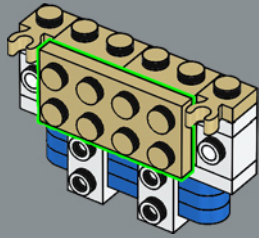

283

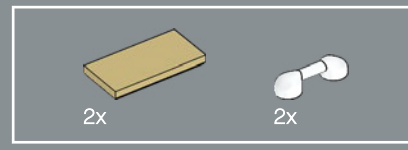
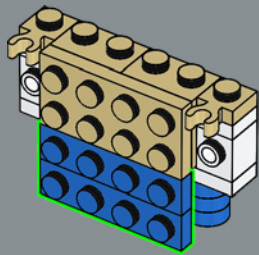

284

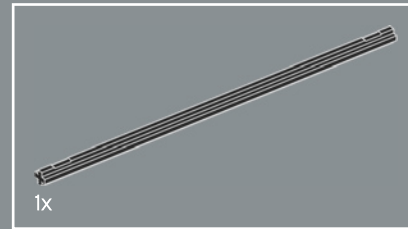
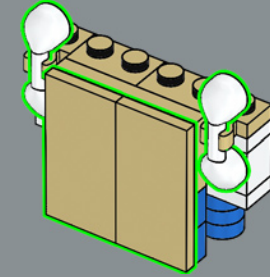

285

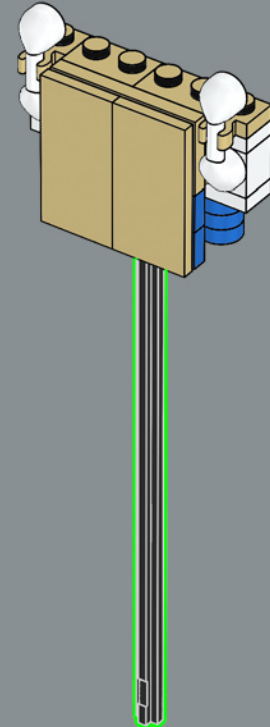

286

